

Wolverine™ Basic Chemical Injection System

334913A
EN

For accurately metering and injecting chemicals at well sites. For professional use only.

Not approved for use in explosive atmospheres or hazardous locations.

See page 2 for model information, including maximum working pressure.



Important Safety Instructions

Read all warnings and instructions in this manual and in other **Related Manuals** on page 2. Save these instructions.

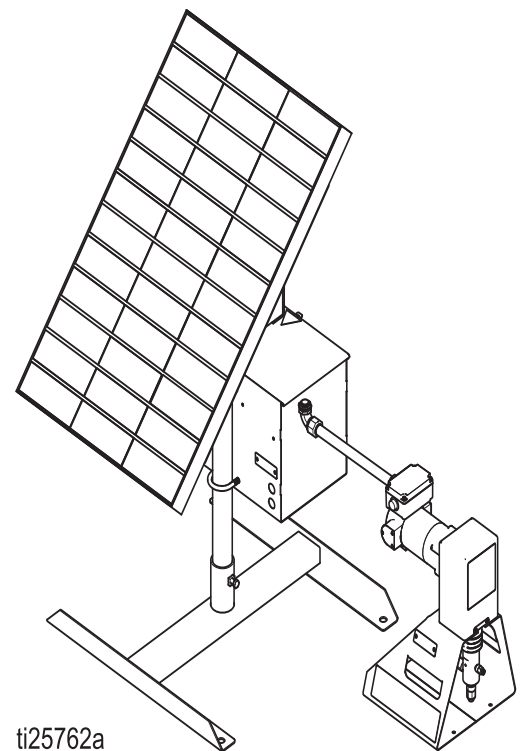

Contents

Related Manuals	2	Pressure Relief Procedure	18
Models	3	Maintenance	19
Warnings	5	Pump Maintenance	19
Installation	7	Solar Panel and Charge Controller Maintenance	19
Accessories	7	Battery Maintenance	19
Typical Installation	8	Sealed Battery Maintenance	21
Setup and Operation	9	Replacing the Battery	22
Assemble Stand Unit	9	Replacing the Fuses	22
Assemble Solar Panel Bracket	10	Troubleshooting	23
Attach Solar Panel to Stand Unit	11	Parts	24
Attach Control Box to Stand Unit	11	Wolverine Basic Chemical Injection System ...	24
Solar Panel Wire Installation	12	Kits and Accessories	26
Pump Installation	13	Technical Data	27
Install the Battery	13	Graco Standard Warranty	28
Connect Battery Wires and Power Up Controller	14		
Calibrate Chemical Dosage	15		
Configuration Run Settings	16		
Time Control Summary	17		

Related Manuals

Manual No.	Description
334513	Wolverine Chemical Injection Pump
3A3097	Harrier LT Controller
--	Charge Controller (included from manufacturer)
--	Solar Panel (included from manufacturer)

Models

Part No.	Configuration	Motor Size	Number of Pumps	Plunger Size	Panel Size (+/- 5 Watts)	Maximum Working Pressure psi (MPa, bar)
B17001	SCI-P12S-125-SA-05E10	S	1	1/4 in.	50	3500 (24.1, 241)
B17002	SCI-P12S-138-SA-05E10	S	1	3/8 in.	50	1500 (10.3, 103)
B17003	SCI-P12S-150-SA-05E10	S	1	1/2 in.	50	800 (5.5, 55)
B17004	SCI-P12S-125-SA-09E10	S	1	1/4 in.	90	3500 (24.1, 241)
B17005	SCI-P12S-138-SA-09E10	S	1	3/8 in.	90	1500 (10.3, 103)
B17006	SCI-P12S-150-SA-09E10	S	1	1/2 in.	90	800 (5.5, 55)
B17007	SCI-P12S-125-SB-05E10	S	1	1/4 in.	50	3500 (24.1, 241)
B17008	SCI-P12S-138-SB-05E10	S	1	3/8 in.	50	1500 (10.3, 103)
B17009	SCI-P12S-150-SB-05E10	S	1	1/2 in.	50	800 (5.5, 55)
B17010	SCI-P12S-125-SB-09E10	S	1	1/4 in.	90	3500 (24.1, 241)
B17011	SCI-P12S-138-SB-09E10	S	1	3/8 in.	90	1500 (10.3, 103)
B17012	SCI-P12S-150-SB-09E10	S	1	1/2 in.	90	800 (5.5, 55)
B17013	SCI-P12S-125-SC-05E10	S	1	1/4 in.	50	3500 (24.1, 241)
B17014	SCI-P12S-138-SC-05E10	S	1	3/8 in.	50	1500 (10.3, 103)
B17015	SCI-P12S-150-SC-05E10	S	1	1/2 in.	50	800 (5.5, 55)
B17016	SCI-P12S-125-SC-09E10	S	1	1/4 in.	90	3500 (24.1, 241)
B17017	SCI-P12S-138-SC-09E10	S	1	3/8 in.	90	1500 (10.3, 103)
B17018	SCI-P12S-150-SC-09E10	S	1	1/2 in.	90	800 (5.5, 55)
B17019	SCI-P12S-125-SD-05E10	S	1	1/4 in.	50	3500 (24.1, 241)
B17020	SCI-P12S-138-SD-05E10	S	1	3/8 in.	50	1500 (10.3, 103)
B17021	SCI-P12S-150-SD-05E10	S	1	1/2 in.	50	800 (5.5, 55)
B17022	SCI-P12S-125-SD-09E10	S	1	1/4 in.	90	3500 (24.1, 241)
B17023	SCI-P12S-138-SD-09E10	S	1	3/8 in.	90	1500 (10.3, 103)
B17024	SCI-P12S-150-SD-09E10	S	1	1/2 in.	90	800 (5.5, 55)
B17025	SCI-P12S-125-SA-09P20	S	1	1/4 in.	90	3500 (24.1, 241)
B17026	SCI-P12S-138-SA-09P20	S	1	3/8 in.	90	1500 (10.3, 103)
B17027	SCI-P12S-150-SA-09P20	S	1	1/2 in.	90	800 (5.5, 55)
B17028	SCI-P12S-125-SB-09P20	S	1	1/4 in.	90	3500 (24.1, 241)
B17029	SCI-P12S-138-SB-09P20	S	1	3/8 in.	90	1500 (10.3, 103)
B17030	SCI-P12S-150-SB-09P20	S	1	1/2 in.	90	800 (5.5, 55)
B17031	SCI-P12S-125-SC-09P20	S	1	1/4 in.	90	3500 (24.1, 241)
B17032	SCI-P12S-138-SC-09P20	S	1	3/8 in.	90	1500 (10.3, 103)
B17033	SCI-P12S-150-SC-09P20	S	1	1/2 in.	90	800 (5.5, 55)
B17034	SCI-P12S-125-SD-09P20	S	1	1/4 in.	90	3500 (24.1, 241)
B17035	SCI-P12S-138-SD-09P20	S	1	3/8 in.	90	1500 (10.3, 103)
B17036	SCI-P12S-150-SD-09P20	S	1	1/2 in.	90	800 (5.5, 55)

Configuration Number Matrix

Check the identification plate (ID) for the 17-part Configuration Number of your system. Use the following matrix to define the components of your system.

NOTE: Not all possible configurations are available.

Sample Configuration Number: SCI-P12S-119-SA-05E10











SCI	P	12	S	1	19	S	A	05	E	1	0
Solar Chemical Injection	Platform	Voltage	Motor	Number of Pumps	Plunger Size	Plunger Material	Seal Material	Solar Panel Wattage	Solar Panel / Battery Package	Controller Package	Qualifier

Platform		Voltage		Motor		Number of Pumps		Plunger Size	
P	Pole Unit	12	12 VDC	S	Small	1	1 Pump	25	1/4" Diameter
								38	3/8" Diameter
								50	1/2" Diameter







Plunger Material		Seal Material		Solar Panel Wattage (+/- 5W)		Solar Panel / Battery Package		Controller Package		Qualifier	
S	17-4 PH Stainless	A	FKM	05	50 Watt	E	Economy	3	Harrier LT w/Economy Solar Panel / Battery Package	0	None
		B	FKMETP	09	90 Watt	P	Premium	4	Harrier LT w/Premium Solar Panel / Battery Package		
		C	BUNA								
		D	FFKM								

Warnings

The following warnings are for the setup, use, grounding, maintenance, and repair of this equipment. The exclamation point symbol alerts you to a general warning and the hazard symbols refer to procedure-specific risks. When these symbols appear in the body of this manual or on warning labels, refer back to these Warnings. Product-specific hazard symbols and warnings not covered in this section may appear throughout the body of this manual where applicable.

 <h1 style="margin: 0;">WARNING</h1>	
 	<p>FIRE AND EXPLOSION HAZARD</p> <p>When flammable fluids are present in the work area be aware that flammable fumes can ignite or explode. To help prevent fire and explosion:</p> <ul style="list-style-type: none"> • Use equipment only in well ventilated area. • Eliminate all ignition sources, such as cigarettes and portable electric lamps. • Ground all equipment in the work area. • Keep work area free of debris, including rags and spilled or open containers of solvent. • Do not plug or unplug power cords or turn lights on or off when flammable fumes are present. • Use only grounded hoses. • Stop operation immediately if static sparking occurs or you feel a shock. Do not use equipment until you identify and correct the problem. • Keep a working fire extinguisher in the work area.
    	<p>SKIN INJECTION HAZARD</p> <p>High-pressure fluid from dispensing device, hose leaks, or ruptured components will pierce skin. This may look like just a cut, but it is a serious injury that can result in amputation. Get immediate surgical treatment.</p> <ul style="list-style-type: none"> • Do not put your hand over the fluid outlet. • Do not stop or deflect leaks with your hand, body, glove, or rag. • Follow the Pressure Relief Procedure when you stop dispensing and before cleaning, checking, or servicing equipment. • Tighten all fluid connections before operating the equipment. • Check fluid lines and couplings regularly. Replace worn or damaged parts immediately.
 	<p>ELECTRIC SHOCK HAZARD</p> <p>This equipment must be grounded. Improper grounding, setup, or usage of the system can cause electric shock.</p> <ul style="list-style-type: none"> • Turn off and disconnect power at main switch before disconnecting any cables and before servicing or installing equipment. • Connect only to grounded power source. • All electrical wiring must be done by a qualified electrician and comply with all local codes and regulations.

WARNING

 	<p>MOVING PARTS HAZARD</p> <p>Moving parts can pinch, cut or amputate fingers and other body parts.</p> <ul style="list-style-type: none"> • Keep clear of moving parts. • Do not operate equipment with protective guards or covers removed. • Pressurized equipment can start without warning. Before checking, moving, or servicing equipment, follow the Pressure Relief Procedure and disconnect all power sources.
 	<p>EQUIPMENT MISUSE HAZARD</p> <p>Misuse can cause death or serious injury.</p> <ul style="list-style-type: none"> • Do not operate the unit when fatigued or under the influence of drugs or alcohol. • Do not exceed the maximum working pressure or temperature rating of the lowest rated system component. See Technical Data in all equipment manuals. • Use fluids and solvents that are compatible with equipment wetted parts. See Technical Data in all equipment manuals. Read fluid and solvent manufacturer's warnings. For complete information about your material, request Safety Data Sheet (SDS) from distributor or retailer. • Turn off all equipment and follow the Pressure Relief Procedure when equipment is not in use. • Check equipment regularly. Repair or replace worn or damaged parts immediately with genuine manufacturer's replacement parts only. • Do not alter or modify equipment. Alterations or modifications may void agency approvals and create safety hazards. • Make sure all equipment is rated and approved for the environment in which you are using it. • Use equipment only for its intended purpose. Call your distributor for information. • Route hoses and cables away from traffic areas, sharp edges, moving parts, and hot surfaces. • Do not kink or over bend hoses or use hoses to pull equipment. • Keep children and animals away from work area. • Comply with all applicable safety regulations.
	<p>TOXIC FLUID OR FUMES HAZARD</p> <p>Toxic fluids or fumes can cause serious injury or death if splashed in the eyes or on skin, inhaled, or swallowed.</p> <ul style="list-style-type: none"> • Read Safety Data Sheet (SDS) to know the specific hazards of the fluids you are using. • Store hazardous fluid in approved containers, and dispose of it according to applicable guidelines.
	<p>PERSONAL PROTECTIVE EQUIPMENT</p> <p>Wear appropriate protective equipment when in the work area to help prevent serious injury, including eye injury, hearing loss, inhalation of toxic fumes, and burns. Protective equipment includes but is not limited to:</p> <ul style="list-style-type: none"> • Protective eyewear, and hearing protection. • Respirators, protective clothing, and gloves as recommended by the fluid and solvent manufacturer.

Installation

Grounding



The equipment must be grounded to reduce the risk of static sparking and electric shock. Electric or static sparking can cause fumes to ignite or explode. Improper grounding can cause electric shock. Grounding provides an escape wire for the electric current.

Pump: grounded through motor. See **Pump Installation** on page 13.

Fluid lines: use only electrically conductive lines.

Fluid supply container: follow local code.

Accessories

Install the following required accessories in the order shown in FIG. 1, using adapters as necessary. See **Kits and Accessories** starting on page 26.

- **Fluid filter (Y-Strainer) (included in M):** with a 60 mesh (250 micron) stainless steel element to filter particles from the fluid before it reaches the pump.
- **Fluid shutoff valves (N):** shuts off fluid flow.
- **Pressure relief valve (F):** overload protection.

Typical Installation

Model B17001 shown

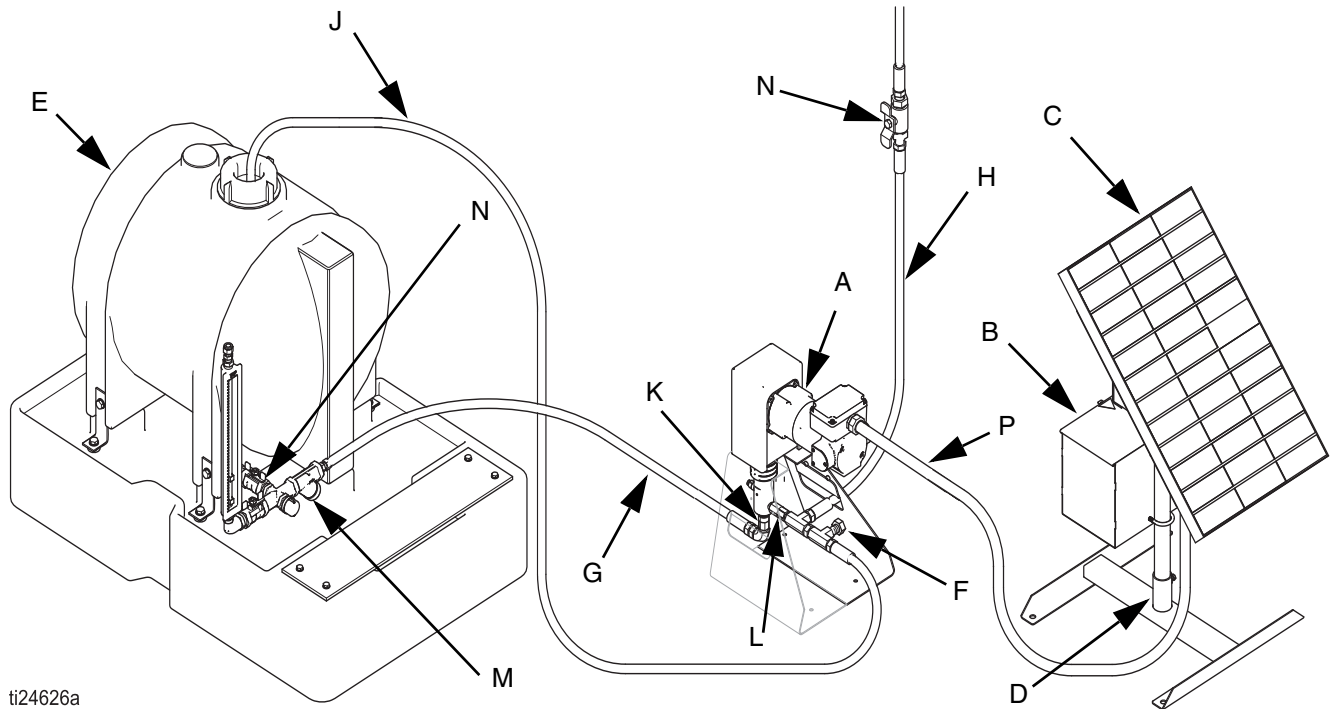

ti24626a

FIG. 1 Chemical Injection System Layout with Wolverine Basic Pump

FIG. 1 is an example of solar system installation with a Wolverine Basic chemical injection system. Your installation may differ from what is shown here.

Components Supplied by Graco

The following components, see FIG. 1, are supplied by Graco:

- A Pump (includes Inlet (K) and Outlet (L) ports)
- B Control Box
- C Solar Panel
- D Stand Unit
- P Conduit from Control Box to the Pump
- Power Cable from Solar Panel to Control Box (not shown)

Components Supplied by Customer

The following components, see FIG. 1, are supplied by the customer:

- E Tank
- F Pressure Relief Valve
- G Inlet Line
- H Outlet Line
- J Pressure Relief Line
- M Manifold Assembly [includes y-strainer and fluid shutoff valve (N)]
- N Fluid Shutoff Valve (inlet & outlet)

Setup and Operation



To reduce the risk of electrical shock, keep battery terminal covers in place at all times, except for when necessary during battery maintenance.

To help prevent serious injury from pressurized fluid, such as skin injection and splashing fluid, follow the Pressure Relief Procedure when you stop dispensing and before cleaning, checking, or servicing the equipment.

Solar panels can attain high temperatures when they are in operation, especially if they are unevenly shaded. Be careful not to touch them without proper personal protection equipment.

Assemble Stand Unit

1. Place the base (4) in the desired location with the middle cross bar pointing true north/south. See FIG. 2.

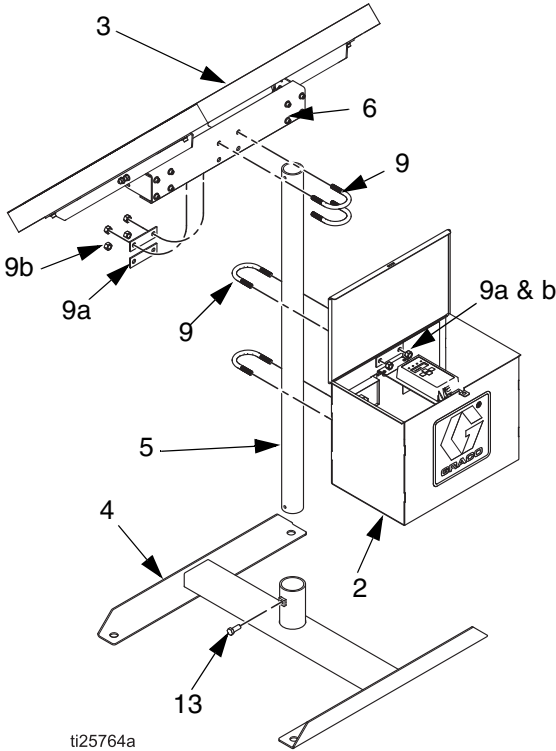

FIG. 2 Stand Unit Assembly

2. Anchor the base (4) with the included stakes (not shown), or by equivalent method.
3. Insert the post (5) into the base and tighten the set screw (13) to keep the pole from rotating.

Assemble Solar Panel Bracket

1. Attach the panel mount adjusters (7) to the solar pole mount hanger (6) with the included screws (11), washers (12), and lock nuts (10). See FIG. 3.

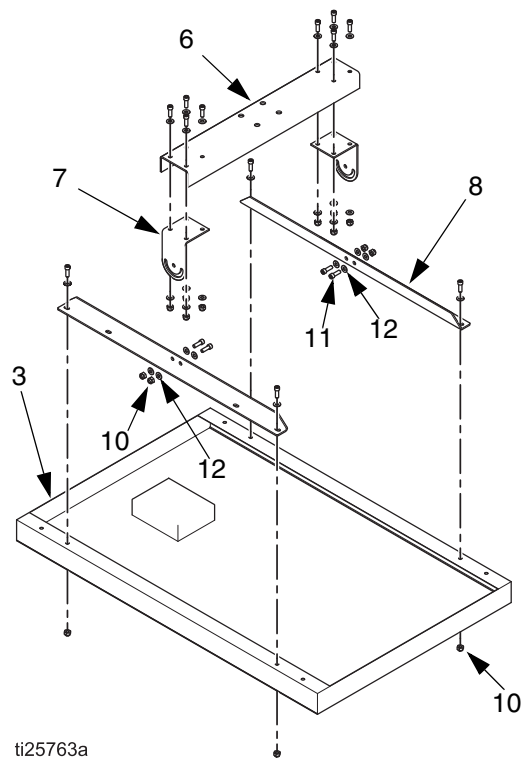





FIG. 3 Rear Solar Panel Bracket Assembly

2. Attach the panel mount brackets (8) to the panel (3) with the included screws (11), washers (12), and lock nuts (10).
3. Attach the panel mount adjusters (7), including the pole mount hanger (6), to the panel mount brackets (8) with the included screws (11), washers (12), and lock nuts (10).

Attach Solar Panel to Stand Unit

				
<p>Damage to either the solar panel's back sheet or glass may result in an electrical or fire risk. Do not attach or install the solar panel:</p> <ul style="list-style-type: none"> • If the back sheet or glass is damaged, • If the terminals are wet, • In adverse weather conditions (high winds, rain, or when ice or snow are present). 				

NOTE: The larger solar panel models are heavy and should be handled by two people when attaching to a stand unit.

1. Loosely attach two u-bolts (9), and their corresponding mounting plates (9a) and nuts (9b), to the solar pole mount hanger (6) attached to the back of the solar panel (3). See FIG. 2.
2. Carefully slide the solar panel assembly onto the pole (5), turn the solar panel (3) and tighten the u-bolt nuts (9b) until the panel is tight to the pole.

NOTE: The panel (3) should face true south if installed in the northern hemisphere, and true north if installed in the southern hemisphere, for maximum efficiency.

3. Set the angle of the solar panel (3) by loosening the screws (11) securing the panel mount brackets (8) to the panel mount adjusters (7). Tilt the panel to the desired angle and tighten the screws (11).

NOTE: The optimal angle for your location is the latitude +15°. See FIG. 4.

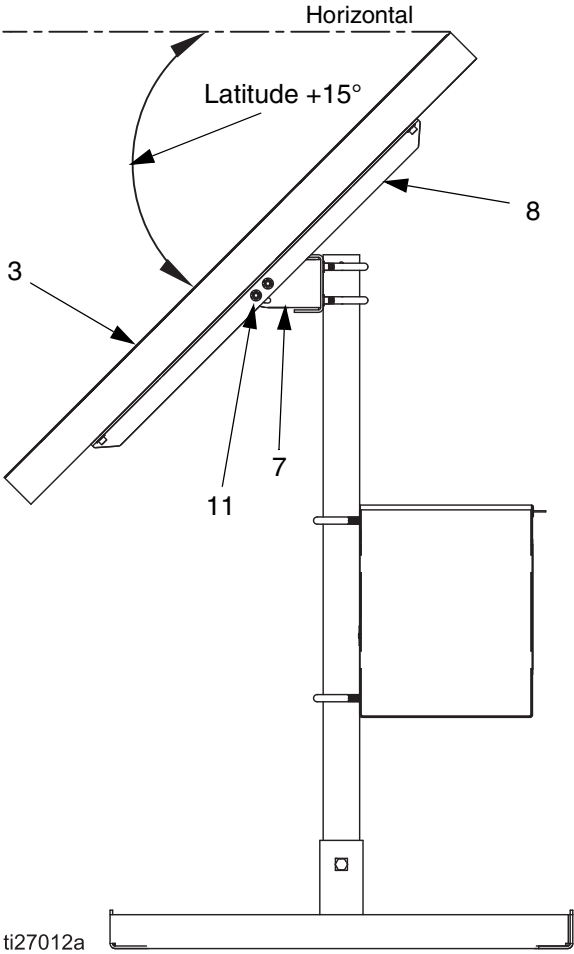

FIG. 4 Optimal Angle of Solar Panel



Attach Control Box to Stand Unit



1. Set the control box (2) on the base (4).
2. Using two u-bolts (9), and their corresponding mounting plates (9a) and nuts (9b), loosely attach the control box (2) to the post (5). See FIG. 2.

NOTE: It is recommended that the control box (2) be mounted facing the opposite direction as the solar panel (3), and that the control box (2) be mounted before the battery is placed inside.

3. Slide the control box (2) up the to the desired height and tighten the nuts (9b) so that the control box is securely attached to the post (5).

Solar Panel Wire Installation

				
<p>Incorrect wiring to the charge controller or battery may result in an electrical or fire risk, and can damage the equipment.</p> <ul style="list-style-type: none"> Do not reverse positive (+) and negative (-) battery or array connections on the charge controller. Do not reverse positive (+) and negative (-) connections on the battery. Do not use a jumper across array negative (-) and battery negative (-) terminals. 				

				
<p>Unexpected activation could occur when power is applied to the controller. Power to the controller comes from the battery and solar panel. To reduce the risk of serious injury, including skin injection, do not wire the battery or solar panel until all fluid lines are connected.</p>				

1. Remove all three fuses (F1, F2, and F3).

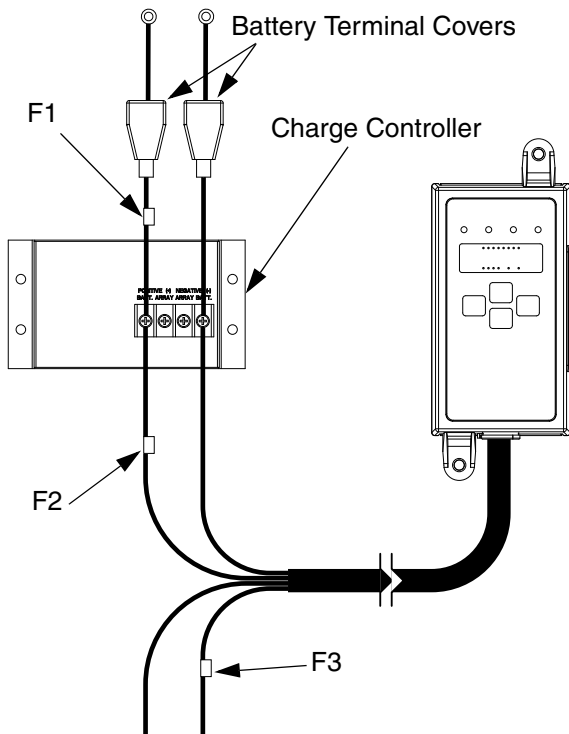

FIG. 5 Control Box Connections (internal)

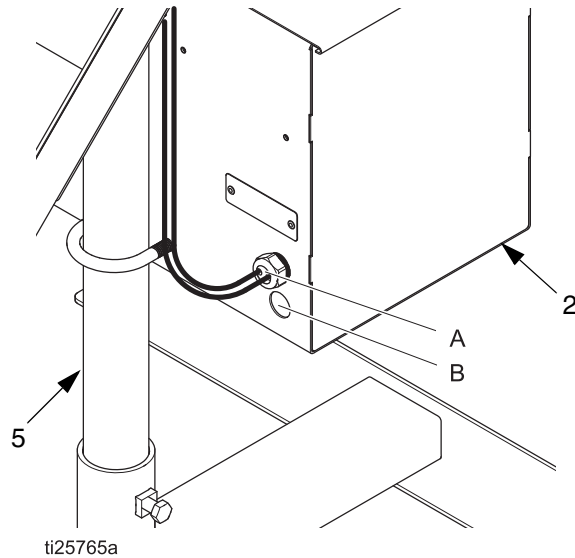

FIG. 6 Control Box Connections (external)

For Economy Systems

NOTE: Economy panels come with a power cable pre-installed with a cord grip and spade terminals for termination at the control box.

1. Insert the cord grip (A) into an open hole on the control box (2), and secure the cord grip using the included nut. See FIG. 6.
2. Terminate the positive and negative wires to the appropriate terminals on the charge controller. Torque to 8 in-lbs (1 N•m). Wire leads are labeled “+” for positive and “-” for negative. The terminals on the charge controller are labeled “ARRAY” and “POSITIVE (+)” for positive, and “NEGATIVE (-)” for negative.

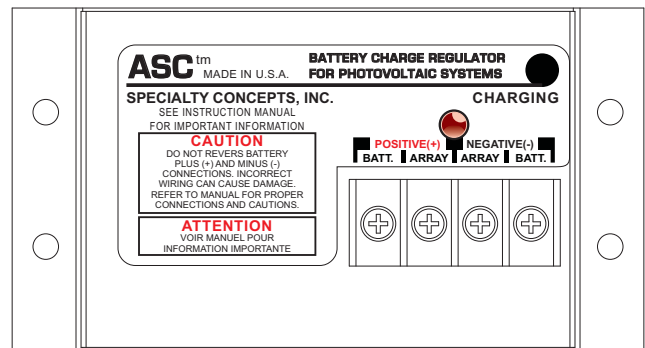

FIG. 7 Charge Controller Connection Detail

3. Route the wires neatly along the post (5) and secure them in place with wire ties (not included).

For Premium Systems

NOTE: Premium panels come with a power cable pre-installed with quick disconnect terminals. Control box comes with a power cable pre-installed with a cord grip and paired quick disconnect terminals to ensure correct polarity.

1. Connect the wires from the solar panel (3) with the wires from the control box (2).
2. Route the wires neatly along the post (5) and secure them in place with wire ties (not included).

Pump Installation



In the event of an injection line blockage, to reduce the risk of skin injection and damage to the pump, ensure the pressure relief valve is set at or below the maximum working pressure of the pump.

Refer to the Wolverine Chemical Injection Pump manual (334513) for pump installation information, including Choosing an Installation Location, Fluid Connections, and Electrical Connections.

To connect the pump to the controller, follow these steps:

1. Ensure all three fuses (F1, F2, & F3) are removed. See FIG. 5.
2. Connect the conduit included on the pump through hole B. See FIG. 6.
3. Connect the green wire from the pump to the ground stud inside the control box.
4. Connect the white wire from the controller to the white wire from the pump.
5. Connect the black wire with the gray stripe from the controller to the black wire from the pump.

Install the Battery



To reduce the risk of electrical shock, keep battery terminal covers in place at all times, except for when necessary during battery maintenance.

Unexpected activation could occur when power is applied to the controller. Power to the controller comes from the battery and solar panel. To reduce the risk of serious injury, including skin injection, do not wire the battery or solar panel until all fluid lines are connected.

1. Ensure all three fuses (F1, F2, & F3) are removed. See FIG. 5.
2. Leave the battery terminal covers installed, if included from the battery manufacturer, until the battery is in place and ready to be wired.
3. Carefully lift the battery up and into the control box (2).



Battery acid could leak out if the system tips over. To reduce the risk of injury, handle the system with care and wear appropriate Personal Protective Equipment.

Connect Battery Wires and Power Up Controller

There are two leads with ring terminals attached to the charge controller. One lead has a red conductor and an in-line fuse holder (F1), and the other has a black conductor.

1. Remove any factory-installed battery terminal covers included from the battery manufacturer.
2. Install the red conductor to the positive battery lug, and the black conductor to the negative lug.
3. Install the battery terminal covers, included on the system wiring, over the battery terminals. See FIG. 5.
4. Reinstall all three fuses (F1, F2, and F3). See FIG. 5.

NOTE: The control unit powers up after this step.

5. Press and hold the controller's up and down arrows simultaneously for 3 seconds to place the unit in setup mode. See FIG. 8 on page 16.

Calibrate Chemical Dosage

NOTE: See Wolverine Chemical Injection Pump manual (334513) for procedure to set stroke adjustment.

After the initial estimate for On time is established, the system should be calibrated to verify injection dosage. The On time setting can be adjusted until the desired injection rate is achieved.

Most calibration gauges are set to a one-minute cycle. Make sure your pump setting is compatible with the cycle of the gauge.

- For a one-minute cycle, make sure the on and off times add up to 60 seconds. Otherwise, make sure your controller cycle time is converted to your gauge cycle. The gauge reading of gallons-per-hour can then be multiplied by 24 to get gallons-per-day.
- For very high flow rates, a 30-second cycle can be used, with the gauge reading multiplied by a factor of two. The chart shows settings that are above pump performance based on location. Refer to expected pump performance for your specific pump to ensure continuous operation on solar power.

CPM	1/4 in. Fluid Plunger Pumps			3/8 in. Fluid Plunger Pumps			1/2 in. Fluid Plunger Pumps			5/8 in. Fluid Plunger Pumps			3/4 in. Fluid Plunger Pumps		
	GPD (LPD)			GPD (LPD)			GPD (LPD)			GPD (LPD)			GPD (LPD)		
	Full Stroke	3/4 Stroke	1/2 Stroke	Full Stroke	3/4 Stroke	1/2 Stroke	Full Stroke	3/4 Stroke	1/2 Stroke	Full Stroke	3/4 Stroke	1/2 Stroke	Full Stroke	3/4 Stroke	1/2 Stroke
5	1.5 (5.8)	1.1 (4.3)	0.8 (2.9)	3.4 (13.0)	2.6 (9.8)	1.7 (6.5)	6.1 (23.2)	4.6 (17.4)	3.1 (11.6)	9.6 (36.2)	7.2 (27.1)	4.8 (18.1)	13.8 (52.1)	10.3 (39.1)	6.9 (26.1)
10	3.1 (11.6)	2.3 (8.7)	1.5 (5.8)	6.9 (26.1)	5.2 (19.5)	3.4 (13.0)	12.2 (46.3)	9.2 (34.7)	6.1 (23.2)	19.1 (72.4)	14.3 (54.3)	9.6 (36.2)	27.5 (104.2)	20.7 (78.2)	13.8 (52.1)
15	4.6 (17.4)	3.4 (13.0)	2.3 (8.7)	10.3 (39.1)	7.7 (29.3)	5.2 (19.5)	18.4 (69.5)	13.8 (52.1)	9.2 (34.7)	28.7 (108.6)	21.5 (81.4)	14.3 (54.3)	41.3 (156.4)	31.0 (117.3)	20.7 (78.2)
20	6.1 (23.2)	4.6 (17.4)	3.1 (11.6)	13.8 (52.1)	10.3 (39.1)	6.9 (26.1)	24.5 (92.7)	18.4 (69.5)	12.2 (46.3)	38.2 (144.8)	28.7 (108.6)	19.1 (72.4)	55.1 (208.5)	41.3 (156.4)	27.5 (104.2)
25	7.6 (29.0)	5.7 (21.7)	3.8 (14.5)	17.2 (65.2)	12.9 (48.9)	8.6 (32.6)	30.6 (115.8)	22.9 (86.9)	15.3 (57.9)	47.8 (181.0)	35.9 (135.7)	23.9 (90.5)	68.8 (260.6)	51.6 (195.5)	34.4 (130.3)
30	9.2 (34.7)	6.9 (26.1)	4.6 (17.4)	20.7 (78.2)	15.5 (58.6)	10.3 (39.1)	36.7 (139.0)	27.5 (104.2)	18.4 (69.5)	57.4 (217.2)	43.0 (162.9)	28.7 (108.6)	82.6 (312.7)	62.0 (234.6)	41.3 (156.4)
35	10.7 (40.5)	8.0 (30.4)	5.4 (20.3)	24.1 (91.2)	18.1 (68.4)	12.0 (45.6)	42.8 (162.2)	32.1 (121.6)	21.4 (81.1)	66.9 (253.4)	50.2 (190.0)	33.5 (126.7)	96.4 (364.9)	72.3 (273.7)	48.2 (182.4)
40	12.2 (46.3)	9.2 (34.7)	6.1 (23.2)	27.5 (104.2)	20.7 (78.2)	13.8 (52.1)	49.0 (185.3)	36.7 (139.0)	24.5 (92.7)	76.5 (289.6)	57.4 (217.2)	38.2 (144.8)	110.2 (417.0)	82.6 (312.7)	55.1 (208.5)
45	13.8 (52.1)	10.3 (39.1)	6.9 (26.1)	31.0 (117.3)	23.2 (88.0)	15.5 (58.6)	55.1 (208.5)	41.3 (156.4)	27.5 (104.2)	86.1 (325.8)	64.5 (244.3)	43.0 (162.9)	123.9 (469.1)	92.9 (351.8)	62.0 (234.6)
50	15.3 (57.9)	11.5 (43.4)	7.6 (29.0)	34.4 (130.3)	25.8 (97.7)	17.2 (65.2)	61.2 (231.7)	45.9 (173.7)	30.6 (115.8)	95.6 (362.0)	71.7 (271.5)	47.8 (181.0)	137.7 (521.2)	103.3 (390.9)	68.8 (260.6)
55	16.8 (63.7)	12.6 (47.8)	8.4 (31.9)	37.9 (143.3)	28.4 (107.5)	18.9 (71.7)	67.3 (254.8)	50.5 (191.1)	33.7 (127.4)	105.2 (398.2)	78.9 (298.6)	52.6 (199.1)	151.5 (573.4)	113.6 (430.0)	75.7 (286.7)
60	18.4 (69.5)	13.8 (52.1)	9.2 (34.7)	41.3 (156.4)	31.0 (117.3)	20.7 (78.2)	73.4 (278.0)	55.1 (208.5)	36.7 (139.0)	114.7 (434.4)	86.1 (325.8)	57.4 (217.2)	165.2 (625.5)	123.9 (469.1)	82.6 (312.7)

NOTE: The chart assumes a motor speed of 60 RPM. Actual motor speed will vary depending on pressure and battery voltage.

Configuration Run Settings

This section is intended as a brief summary of controller operation. Please see the related Harrier LT Controller manual (3A3097) for complete detailed operation procedures.

NOTICE

To prevent damage to soft key buttons, do not press the buttons with sharp objects such as pens, plastic cards, or fingernails.

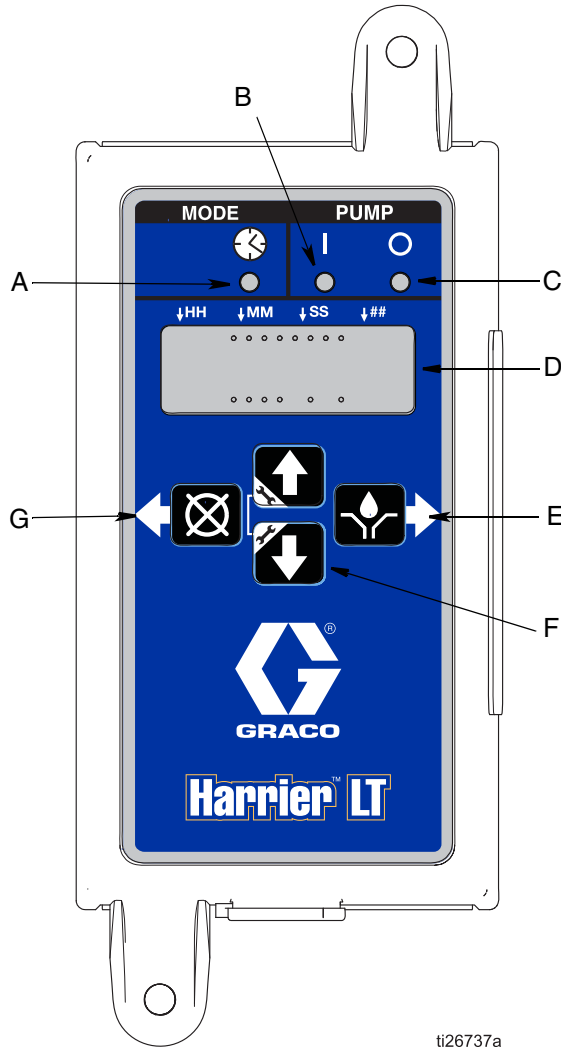

FIG. 8 Harrier LT Controller

ti26737a

Mode LEDs (A)

- A Time Mode LED: Indicates when the controller is operating in Time Mode.

Pump LEDs (B & C)

- B On LED: In Run Mode, this LED illuminates when in the On portion of the Run Cycle.
- C Off LED: In Run Mode this LED illuminates when in the Off or Reset portion of the Run Cycle.

Display (D)

- A blinking field or text on the display indicates the controller is in Setup Mode.
- In Run Mode numbers on the display will not blink.

Right Direction Arrow / Manual Run / Enter (E)

- In Setup Mode, saves entry, moves cursor in display one field to the right or to the next setup step.
- In Run Mode activates the pump for one complete On Cycle if actuated during the Off portion of the Run Cycle.

Up and Down Direction Arrows (F)

- Press and hold both the Up and Down Arrow keys together for 3 seconds to enter Setup Mode.
- In Setup Mode increase or decrease number values associated with the various Run Modes.

Left Direction Arrow / Reset (G)

- In Setup Mode moves cursor in display one field to the left.
- In Run Mode, Pressing Reset starts a Pump Off cycle.
- In Alarm Mode, Press and hold for 3 seconds to clear warning and switch controller to Run starting in the Off Cycle.

Time Control Summary

In Time mode, you can choose the on time and off time. Adjusting the on and off times allows the user to control both the dosing of chemicals and the frequency at which the pump runs.

The left and right arrows select the digit to modify, while the up and down arrows modify the selected digit. When time mode is first selected, the hours and minutes are displayed.

If you scroll to the right past the last minute digit, the seconds will then display. The lighted indicators above the LCD display indicate whether the modification digit is hours, minutes, or seconds.

Pressure Relief Procedure



Follow the Pressure Relief Procedure whenever you see this symbol.



This equipment stays pressurized until pressure is manually relieved. To help prevent serious injury from pressurized fluid, such as skin injection and splashing fluid, follow the **Pressure Relief Procedure** when you stop dispensing and before cleaning, checking, or servicing the equipment.

The bleed valve is ported with a 10-32 UNF thread. It is required that a hose be connected to control the relieved fluid. See Wolverine Chemical Injection Pump manual (334513) for more information.

NOTE: Always discharge fluid into an approved container or location.

1. Disconnect main power from pump by removing the fuse (F3) on the controller's positive motor output wire (white).
2. Shut off the inlet and outlet lines using shutoff valves (N).
3. Slowly crack the fitting connected to the outlet check valve to relieve downstream fluid pressure.

4. Open bleed valve by turning needle counter-clockwise with a flathead screwdriver to relieve internal pump fluid pressure. See FIG. 9.

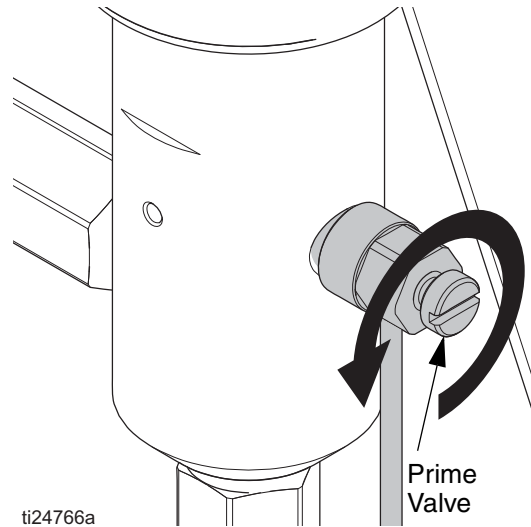

FIG. 9 Bleed Valve

5. Disconnect and cap inlet and outlet fluid lines.
6. Pressure has now been relieved, perform any required maintenance.
7. When ready to put the pump back into operation, reinstall the fuse (F3) and **Prime the Pump** (see Wolverine Chemical Injection Pump manual (334513) for procedure).
8. If required, **Calibrate Chemical Dosage** on page 15.

Maintenance

Pump Maintenance

See the Wolverine Chemical Injection Pump manual (334513).

Solar Panel and Charge Controller Maintenance

See the manuals supplied with the solar panel and charge controller.

Battery Maintenance

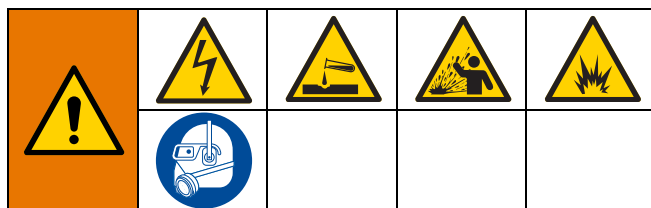

Batteries contain sulfuric acid and produce explosive mixtures of hydrogen and oxygen. Improper installation or maintenance may result in electric shock, chemical burns, or explosion. Self-discharge action generates hydrogen gas even when the battery is not in operation. Battery maintenance must only be performed by personnel knowledgeable of batteries and the required precautions.

- Always wear proper eye, face, and hand protection.
- Keep all sparks, flames, and cigarettes away from the battery.
- Never try to open a battery with non-removable vents.
- Keep removable vents tight and level except when servicing electrolyte.
- Use and store only in a well-ventilated area.
- Never lean over battery while boosting, testing, or charging.
- Exercise caution when working with metallic tools or conductors to prevent short circuits and sparks.

Inspect and Clean the Battery

1. Remove the fuse (F1) from the red wire that connects the positive terminals of the charge controller and the battery. See FIG. 5.
2. Remove the fuse (F2) from the red wire that connects the positive terminals of the charge controller and the Harrier LT controller. See FIG. 5.
3. Examine the outside appearance of the battery.
 - a. Look for cracks in the container and verify that top of the battery, posts, and connections are clean and free of dirt, fluids, and corrosion.
 - b. Wipe down dirty batteries with a damp cloth, using a mixture of baking soda and water.
 - c. Remove the battery terminal covers, clean off any corrosion from the terminals with a wire brush and reinstall battery terminal covers.

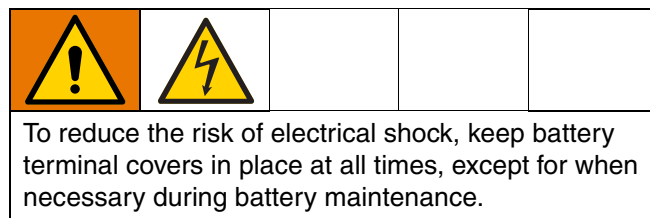

- d. Replace any damaged batteries.

NOTE: Any fluids on or around the battery may be an indication that electrolyte is spilling, leaching, or leaking out. Leaking batteries must be replaced.

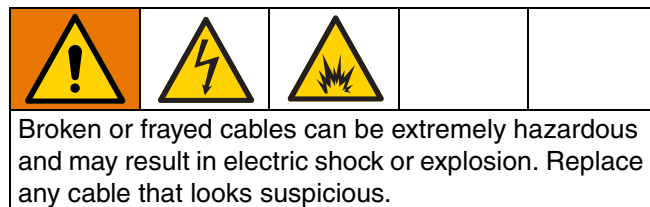

4. Check all battery cables and their connections.
 - a. Look closely for loose or damaged parts and verify battery cable are intact.

5. Tighten all wiring connections. Torque to 10 ft-lbs (14 N•m). Make certain there is good contact with the terminals.
6. Reinstall the fuses removed in steps 1 and 2.

Check Electrolyte Levels (Flooded Batteries Only)

1. Remove the battery’s removable vent caps using a flat-blade screwdriver.
2. Visually inspect the electrolyte (water) level. Do not add water if the electrolyte level is between 1/2 inch above the plates or 1/8 inch below the vent well.

NOTE: Over-filled batteries, which raise the water level into the vent well, can result in water loss (when recharged) and seepage (during normal use).

3. If the battery electrolyte (water) level is low, refill with distilled water.

NOTE: Never use pre-mixed electrolytes. Battery additives are not recommended, and will void the battery warranty.

4. Replace battery’s vent caps.
5. Charge the battery.

Check the Battery State of Charge

A battery hydrometer, which measures a battery liquid’s specific gravity, is the most accurate way of assessing the battery’s state of charge.

Voltage readings can sometimes be misleading immediately after a recharge because of the battery’s surface charge.

Use the table below to determine the battery’s state of charge based on either it’s voltage reading or specific gravity.

NOTE: Surface charge is an artificially high voltage reading caused by a high concentration of acid near the plates during, and immediately after, charging. A hydrometer reading can also be affected by surface charge, but to a lesser degree than a voltage reading.

State of Charge	Open Circuit Voltage	Specific Gravity
Full Charge	12.84	1.300
90%	12.73	1.282
80%	12.65	1.268
70%	12.57	1.255
60%	12.49	1.242
50%	12.41	1.228
40%	12.33	1.215
30%	12.25	1.202
20%	12.17	1.188
10%	12.09	1.175
0	12.01	1.162

Charge the Battery



Improper battery charging can result in electric shock, chemical burns, or explosion:

- Never attempt to charge a battery without first reviewing the instructions for the charger being used.
- Never try to charge a visibly damaged battery.
- Do not attempt to charge a frozen battery.
- Always charge batteries in a well-ventilated area.

NOTICE

Improper battery charging is one of the most detrimental factors to a battery's performance and service life.

Batteries stored in a discharged condition for extended periods can permanently sulfate and suffer significant capacity loss in the process.

Most battery chargers are constant voltage (voltage-regulated) chargers. This means that current flow is managed by charger voltage. Use an automatic voltage-controlled charger set for the correct battery type whenever possible to prevent problems if the battery cannot be monitored while charging.

NOTE: Successful charging will require about 115% of the amp-hour, or charge, expended.

1. **Check Electrolyte Levels (Flooded Batteries Only)**, page 20.
2. Leave the vent caps on when recharging. The vent caps are flame arrestor safety caps designed to trap the normal gasses produced during charging and allow the recombination of these gasses back to water.
3. Verify the charger leads to the battery are not broken, frayed, or loose.
4. Observe and verify the correct polarity when connecting the charger leads.
5. If the battery becomes hot, or if violent gassing or spewing of electrolyte occurs, reduce the charging rate or turn off the charger temporarily.

NOTE: Generally, the maximum charging current is 20% of the battery's amp-hour capacity.

Battery Storage

1. Follow all steps outlined in **Battery Maintenance**, page 19.

NOTICE

Do not store batteries in a discharged state. Batteries stored in a discharged state are susceptible to freezing, sulfation, and an increased rate of discharge. A fully charged battery will not freeze unless the temperature reaches approximately -80°F (-62°C). If discharged, it can freeze at 32°F (0°C).

Charge batteries before storing.

2. Store the battery in a dry, cool, well-ventilated area [the cooler the better, without going below 32°F (0°C)], and out of reach of children and pets.
3. Check the water level and state of charge every 45-60 days.

Sealed Battery Maintenance

Sealed batteries can only be maintained by checking voltage readings using a digital or analog volt meter with the following tests and readings:

- If the voltage readings are below 12.84v static (no loads pulling or discharging) the battery needs to be charged.
- If a conductance tester is used to determine pass/fail, replace the battery if it fails.
- If a carbon pile load tester is used, applying ½ the CCA rating of the battery for 15 seconds, the battery voltage (at 70°F/21°C) should not fall below 9.6 volts after 15 seconds.

Replacing the Battery

When replacing the battery, replace with like kind or better (i.e., replace an economy battery with a premium battery). See below for specifications. Replacement batteries are available from Graco.

Systems with an E in the configuration key (SCI-X12X-XXX-XX-XXEEX)

- Voltage: 12 V
- Size: 27
- Rated Amp Hours: 96

Systems with a P in the configuration key (SCI-X12X-XXX-XX-XXPXX)

- Voltage: 12 V
- Size: 31
- Rated Amp Hours: 105

Replacing the Fuses

See FIG. 5 for fuse identification.

NOTICE
<p>Fuses are supplied, and are required on all models. To avoid equipment damage:</p> <ul style="list-style-type: none"> • Never operate the pump or system without a fuse installed. • A fuse of the correct voltage and amperage must be installed in line with the power entry to the system. • See tables below for current rating.

Replacement fuses are available from Graco.

- Voltage Rating: 32 VDC
- Current Rating: See tables below
- Style: Automotive Mini (ATM)

Replacement Fuses Between Charge Controller and Battery (F1)

Model	Current Rating
SCI-XXXX-XXX-XX-05XXX	10 A
SCI-XXXX-XXX-XX-09XXX	10 A

Replacement Fuses Between Charge Controller and Harrier LT Controller (F2)

Model	Current Rating
SCI-X12S-XXX-XX-XXXXX	15 A

Replacement Fuses Between Harrier LT Controller and Wolverine Pump (F3)

Model	Current Rating
SCI-X12S-XXX-XX-XXXXX	15 A

Troubleshooting

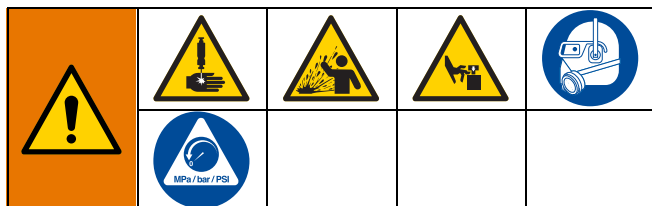

1. Follow **Pressure Relief Procedure**, page 18, before checking or repairing the system.

Problem	Cause	Solution
System stops running	Battery charge too low	Charge battery. Replace if problem persists.
	Fuse blown	Replace fuse with like kind. Find short if problem persists.
Fluid delivery is slow	Large pressure drop in hose	Use larger diameter or shorter hose.
	Program settings are incorrect	Reset and recalibrate program settings.
	Pressure is too high	Verify outlet line pressure is lower than maximum working pressure of the pump.
	Pump is not primed	Follow priming procedure.

NOTES:

- Refer to the Wolverine Chemical Injection Pump manual (334513) for troubleshooting specific to the pump.
- Refer to the Harrier LT Chemical Injection Controller manual (3A3097) for troubleshooting specific to the controller.
- Refer to the included solar panel manual for troubleshooting specific to the solar panel.
- Refer to the included charge controller manual for troubleshooting specific to the charge controller.

Parts

Wolverine Basic Chemical Injection System

Model B17001 shown

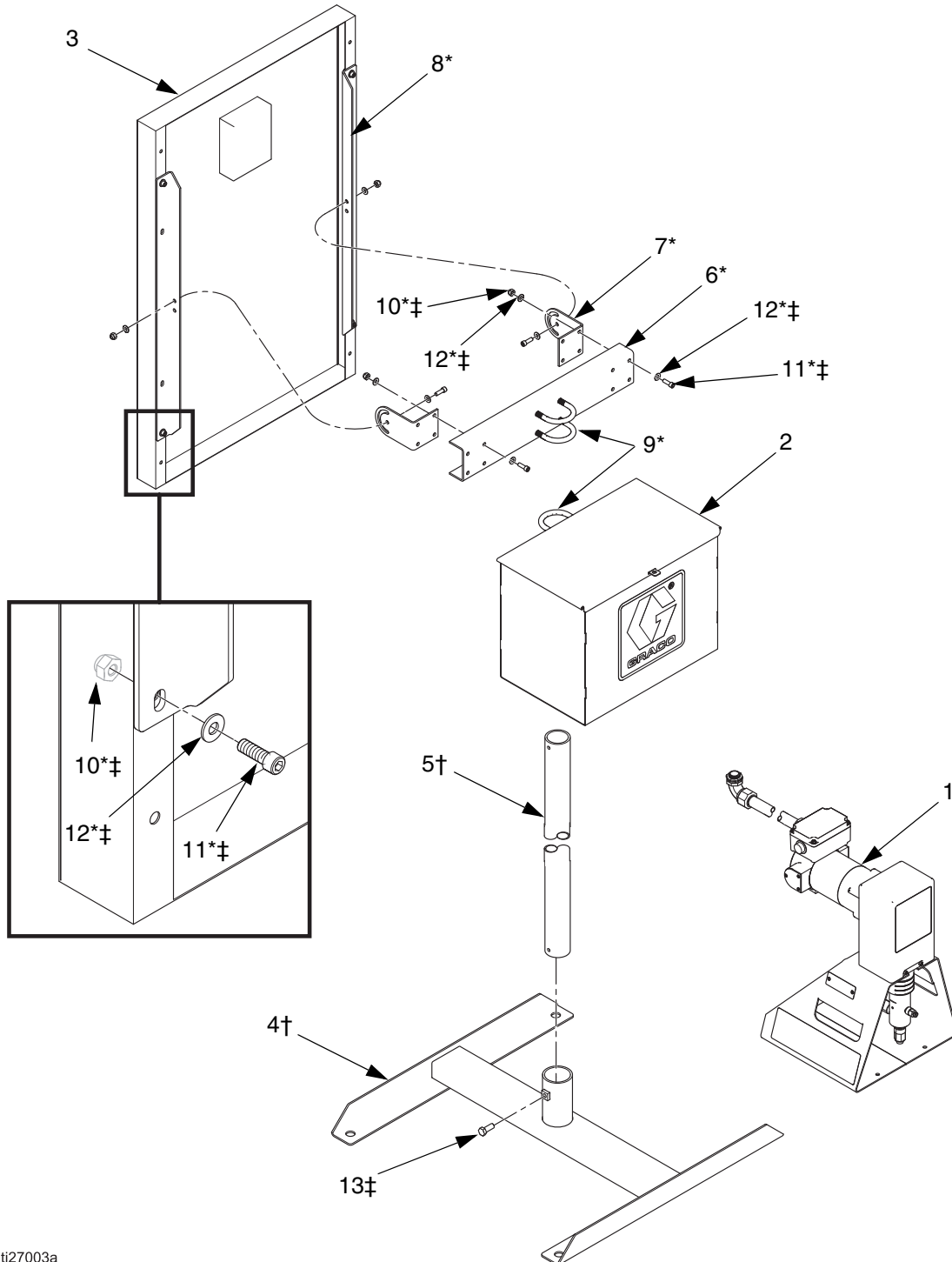

ti27003a

System Parts List

Ref.	Part	Description	Qty
1	See Models , pg 3	Wolverine Basic pump	1
2	B32950	Control Box, Harrier LT w/Economy Solar Panel / Battery Package	1
	B32951	Control Box, Harrier LT w/Premium Solar Panel / Battery Package	1
3	B32016	Solar Panel, Economy, 50 W	1
	B32014	Solar Panel, Economy, 85 W	
	B32018	Solar Panel, Premium, 50 W	
	B32017	Solar Panel, Premium, 90 W	
4†	B32600	Stand Base	1
5†	B32601	Stand Pole	1
6*	--	Pole Mount Hanger	1
7*	--	Panel Mount Adjusters	2
8*	--	Panel Mount Brackets	2
9*	--	U-bolts (includes mounting plates and nuts)	4
10*‡	--	Lock Nuts	16
11*‡	--	Socket Head Screws	16
12*‡	--	Washers	28
13‡	--	Hex Head Screw	1
14	B32073	Stand Anchoring Post (not shown)	4
17	B32020	Battery, Economy (not shown)	1
	B32019	Battery, Premium (not shown)	1

* Parts included in B32602 (Solar Panel Mounting Kit).

† Parts included in B32009 (Stand Pole and Base Kit).

‡ Parts included in B32616 (System Hardware Kit).

Kits and Accessories

Part No.	Description
B32010	8 Amp Charge Controller
B32070	15 Amp Fuse Kit (10)
B32074	10 Amp Fuse Kit (10)
B32110	Harrier LT Chemical Injection Controller
B32605	Wolverine Basic Control Box
B32606	Harrier LT Controller Mounting Bracket
B32607	Wolverine Basic Battery Cables, positive (+) and negative (-)
B32614	Premium Solar Panel Cable
B32161	Solar Panel Pole, 6 ft. (1.8 m)

Technical Data

Solar-Powered Chemical Injection Systems		
	US	Metric
Maximum Fluid Working Pressure		
1/2" Plunger Pump	800 psi	5.5 MPa, 55 bar
3/8" Plunger Pump	1500 psi	10.3 MPa, 103 bar
1/4" Plunger Pump	3500 psi	24.1 MPa, 241 bar
Fluid Inlet Fitting	1/4" NPT(F)	
Fluid Outlet Fitting	1/4" NPT(F)	
Nominal Voltage	12 VDC	
Maximum Current	15 amps	
Wetted Parts	See Wolverine Chemical Injection Pump manual (334513)	
Operating Temperature Range within the Enclosure	-40 - 131°F	-40 - 55°C
Maximum sound pressure	<70 dBa	
Overall Dimensions (L x W x H)	23" x 24" x 96"	0.58 m x 0.61 m x 2.44 m
Weight		
System	160 lbs	73 kg
Pump	35 lbs	16
Battery	61 lbs	28
Solar Panel		
50 W	15 lbs	6.8
90 W	21 lbs	9.5
Stand w/pole	28 lbs	13
Control Box (without battery)	15 lbs	5.8

Graco Standard Warranty

Graco warrants all equipment referenced in this document which is manufactured by Graco and bearing its name to be free from defects in material and workmanship on the date of sale to the original purchaser for use. With the exception of any special, extended, or limited warranty published by Graco, Graco will, for a period of twelve months from the date of sale, repair or replace any part of the equipment determined by Graco to be defective. This warranty applies only when the equipment is installed, operated and maintained in accordance with Graco's written recommendations.

This warranty does not cover, and Graco shall not be liable for general wear and tear, or any malfunction, damage or wear caused by faulty installation, misapplication, abrasion, corrosion, inadequate or improper maintenance, negligence, accident, tampering, or substitution of non-Graco component parts. Nor shall Graco be liable for malfunction, damage or wear caused by the incompatibility of Graco equipment with structures, accessories, equipment or materials not supplied by Graco, or the improper design, manufacture, installation, operation or maintenance of structures, accessories, equipment or materials not supplied by Graco.

This warranty is conditioned upon the prepaid return of the equipment claimed to be defective to an authorized Graco distributor for verification of the claimed defect. If the claimed defect is verified, Graco will repair or replace free of charge any defective parts. The equipment will be returned to the original purchaser transportation prepaid. If inspection of the equipment does not disclose any defect in material or workmanship, repairs will be made at a reasonable charge, which charges may include the costs of parts, labor, and transportation.

THIS WARRANTY IS EXCLUSIVE, AND IS IN LIEU OF ANY OTHER WARRANTIES, EXPRESS OR IMPLIED, INCLUDING BUT NOT LIMITED TO WARRANTY OF MERCHANTABILITY OR WARRANTY OF FITNESS FOR A PARTICULAR PURPOSE.

Graco's sole obligation and buyer's sole remedy for any breach of warranty shall be as set forth above. The buyer agrees that no other remedy (including, but not limited to, incidental or consequential damages for lost profits, lost sales, injury to person or property, or any other incidental or consequential loss) shall be available. Any action for breach of warranty must be brought within two (2) years of the date of sale.

GRACO MAKES NO WARRANTY, AND DISCLAIMS ALL IMPLIED WARRANTIES OF MERCHANTABILITY AND FITNESS FOR A PARTICULAR PURPOSE, IN CONNECTION WITH ACCESSORIES, EQUIPMENT, MATERIALS OR COMPONENTS SOLD BUT NOT MANUFACTURED BY GRACO. These items sold, but not manufactured by Graco (such as electric motors, switches, hose, etc.), are subject to the warranty, if any, of their manufacturer. Graco will provide purchaser with reasonable assistance in making any claim for breach of these warranties.

In no event will Graco be liable for indirect, incidental, special or consequential damages resulting from Graco supplying equipment hereunder, or the furnishing, performance, or use of any products or other goods sold hereto, whether due to a breach of contract, breach of warranty, the negligence of Graco, or otherwise.

FOR GRACO CANADA CUSTOMERS

The Parties acknowledge that they have required that the present document, as well as all documents, notices and legal proceedings entered into, given or instituted pursuant hereto or relating directly or indirectly hereto, be drawn up in English. Les parties reconnaissent avoir convenu que la rédaction du présente document sera en Anglais, ainsi que tous documents, avis et procédures judiciaires exécutés, donnés ou intentés, à la suite de ou en rapport, directement ou indirectement, avec les procédures concernées.

Graco Information

For the latest information about Graco products, visit www.graco.com.

For patent information, see www.graco.com/patents.

TO PLACE AN ORDER, contact your Graco distributor or call to identify the nearest distributor.

Phone: 612-623-6921 **or Toll Free:** 1-800-328-0211 **Fax:** 612-378-3505

All written and visual data contained in this document reflects the latest product information available at the time of publication. Graco reserves the right to make changes at any time without notice.

Original instructions. This manual contains English. MM 334913

Graco Headquarters: Minneapolis

International Offices: Belgium, China, Japan, Korea

GRACO INC. AND SUBSIDIARIES • P.O. BOX 1441 • MINNEAPOLIS MN 55440-1441 • USA
Copyright 2015, Graco Inc. All Graco manufacturing locations are registered to ISO 9001.

www.graco.com

Revision A, August 2015