

CVS Plus

SUCTION MANIFOLD



CE

OPERATING INSTRUCTIONS

86-1042 iss.2

 **TRIDAC**

SYMBOLS USED ON LABELS :

Symbol	Explanation
	Type B equipment, according to BS EN 60601-1
	ATTENTION! Refer to accompanying documents
	Class 1 product compliant with Directive 93/42/EEC (Medical Devices Directive)

CONTENTS

- 1) DESCRIPTION
- 2) ELECTROMAGNETIC ENVIRONMENT
- 3) SERVICING
- 4) SPECIFICATIONS AND RATINGS
- 5) INSTALLATION
- 6) OPERATION
- 7) ROUTINE CLEANING & MAINTENANCE
- 8) THIRD PARTY MAINTENANCE
- 9) SPARES & ACCESSORIES

CARE & MAINTENANCE SUMMARY

INSTRUCTION REFERENCE

AFTER EACH USE:

FLUSH USED OPERATING HOSES WITH A TUMBLER OF WATER.	7.2
CLEAN & STERILISE ASPIRATOR TIPS	7.7

TWICE PER DAY:

CHECK AND, IF NECESSARY, EMPTY SOLIDS FILTER	7.4
--	-----

ONCE PER DAY:

FLUSH OPERATING HOSES	7.3
CLEAN OPERATING HOSES	7.5
CLEAN SOLIDS FILTER	7.4
WIPE OVER EXTERNAL SURFACES	7.8

AT LEAST ONCE PER WEEK:

CLEAN ROTARY VALVES	7.5
CLEAN ACCESSIBLE MANIFOLD AIRWAYS	7.6

ONCE PER MONTH:

CLEAN ALL MANIFOLD AIRWAYS	7.6
----------------------------	-----

TRIDAC CVS Plus SUCTION MANIFOLDS

P/NOS. 22 1167, 22 1211, 22 1306

1) DESCRIPTION

The Tridac CVS plus suction manifold is intended for use in conjunction with existing suction systems. It provides 3 operating hoses, one large and two small. Each hose has a rotary shut off valve to control the degree of suction. The set of three hoses is assembled to a manifold connector which is a plug fit into the manifold itself. The hose set is thus easily detachable for cleaning.

The large hose is intended for use with 16 mm suction tips (spray interceptor) and the small for 11 mm tips, such as surgical tips and saliva ejectors. An adaptor converting the large hose to the 11 mm size is available and can be used to maximise air flow through larger surgical tips (8 mm bore).

A filter incorporated into the manifold is placed between the operating hoses and the suction supply line, in order to separate solids particles from the air and liquid flow. The filter is easily extracted for emptying and cleaning.

The manifold is available in variations to suit either:

- a) Wet-line suction systems, or
- b) Dry-line & semi dry-line systems.

For variations a), the manifold hanger incorporates single microswitches in each of the hose holders. The switches may be used to 'signal' demand for the suction pump (typically operating a motor start relay) or to operate a suitable vacuum shut off valve. The suction supply line provided is a smaller diameter and less flexible than that used for dry-line systems, because of the higher vacuum levels associated with wet-line pumps.

For variations b), the manifold hanger is available with either single or twin microswitches in each of the hose holders. The twin switch version allows operation of a vacuum shut off valve and a 'signal' to demand the pump.

The suction supply line is a larger diameter and more flexible than that used for wet-line systems, in order to maintain high flow rates at the lower vacuum levels associated with dry-line pumps.

2) ELECTROMAGNETIC ENVIRONMENT

The CVS plus has been tested as satisfying the electromagnetic compatibility (EMC) requirements of international standard EN 60601-1-2 when installed as part of an integrated spittoon/suction unit. This means that the tested product type should operate within the intended environment of use without causing unacceptable deterioration in the performance of other electrical apparatus or appliances and should not suffer unacceptable deterioration in its own performance as a result of the operation of such apparatus or appliances.

When used in other applications the type and nature of any electrical circuit to which the CVS plus is connected can have an effect on EMC performance. The installed EMC performance is thus outside our control.

However, problems (e.g. switch clicks) are unlikely to occur if the CVS plus is utilised in the 'typical' circuit configurations indicated in this booklet, if the recommendations in the ratings are adhered to and if good engineering practice is followed. Susceptibility to electromagnetic effects is extremely unlikely for the kind of applications indicated. Performance of the mains side of such circuits, which may be existing relay contacts and/or suction pumps, will not be influenced by the suction manifold switches.

Should it be suspected that operation of the unit is causing adverse effects in other electrical equipment as a result of EMC performance, users should contact Tridac for guidance and advice.

The intended environments of use envisaged are dental surgeries as typically found in domestic, commercial and light industrial premises, as well as general medical premises, such as hospital dental departments and clinics.

3) SERVICING AND REPAIRS

Servicing and repairs outside those tasks indicated as user maintenance should be entrusted to the equipment supplier, who will have the appropriately qualified personnel to carry out such tasks. Should any difficulty be experienced in obtaining satisfactory service, users should contact Tridac for advice.

Diagrams and component parts lists will be made available by Tridac to suitably qualified personnel, as will guidance on the repair of those parts deemed repairable. Repairers requiring assistance may contact Tridac by telephone on +44 (0)1923 242398, or write to the address given in the specifications section of this booklet.

4) SPECIFICATIONS AND RATINGS

Manufacturer

Unit 13, The Wenta Business Centre, Colne Way, Watford, WD24 7ND
~~Tridac Ltd, Elton House, Dushy Hall Road, Watford, Herts. WD2 2HD, England.~~

Model Reference

22 1167: CVS plus, for wet-line, with single pole switches.
22 1211: CVS plus, for dry-line, with single pole switches.
22 1306: CVS plus, for dry-line, with double pole switches.

Transport and Storage

The unit and packaging are suitable for transport and storage in an environment with a temperature range of 0 to 50 deg.C and relative humidity of 30% to 95%

Installation Type

Permanently installed

Classification (EN 60601-1)

Class 1. Warning: This equipment must be earthed

Equipment type (EN 60601-1)



Type B

Anaesthetic Category

NOT AP/APG. Do not use near flammable gases

Classification under Directive 93/42/EEC (Medical Devices):

Class I (passive suction device)

Electrical Ratings:- Switch contacts

Safety Extra Low Voltage to EN 60601-1 must be ensured.

24 volts ac/dc, 50/60 Hz, 2 Amps max, resistive load.

Note : Derate for inductive loads e.g. contactor coils.

Suppress D.C. coils e.g. use a catch diode across the coil.

If possible, use coils with ratings not exceeding 10VA ac/dc

Mode of operation

Continuous

Vacuum

Intended for connection to existing suction sources.

Note :- Draft International Standards suggest safe vacuum levels should not exceed -250 hPa.

Vacuum connection

Dry-line : 32 mm flexible ducting.

Wet line : 19 mm flexible ducting.

Dimensions of housing

Width: 165 mm

Height: 95 mm

Depth: 80 mm

Solids filter

Material: Stainless steel

Diameter 21 mm

Length 63 mm

Mesh 0.7 mm

ACCESSORIES

Suction tips

Will accept 16 mm and 11 mm diameter tips.

5) INSTALLATION

5.1) General

The vacuum line and wiring may enter the housing from the underside or from the rear and may be selected on installation.

To reposition services, remove the operating hose assembly and the two screws on the underside of the housing. The front cover may then be lifted away. Pull out the filter, then remove the inlet elbow by swinging up and pulling to the right. Then gently spring the bracket to one side to allow removal of the tee fitting.

Pass the wire through the large hole, fitting or removing grommet from the adjacent slot. Replace tee fitting in desired position making sure that the plain end without an 'O' ring is on the left hand side. Reconnect the elbow and swing down into position. If the wiring is to exit from the underside, place grommet in slot adjacent to the tee.

Site the manifold in the required position and fix in place using either the two threaded inserts (2BA) or two plain holes in the housing back plate. Note:- The manifold housing will also fit directly onto a Tridac swing arm (P/No. 22 1076) without an adaptor plate.

If the manifold is to be surface mounted, two holes may have to be made in the mounting surface, depending on the chosen entry for the services (see template 85 1056)

Refit the front cover of the manifold by hooking the top edge onto the lip of the back and secure with the two screws. Replace the filter and attach the operating hoses.

The vacuum supply hose is supplied with a push in manifold connection already attached to one end. The other end is left plain and will need adapting to the vacuum line or separator in the host suction system.

If the switches are to be utilised to give auto selection the green and yellow wire must be connected to earth. The red and blue wires are switched as shown in the diagrams appended.

5.2) Suction source

The degree of suction is varied by rotary valves in the tip connectors of the CVS plus, which act by restricting the orifice of the hose. When all tip connector valves are adjusted to their shut off position, air flow into the hoses is reduced to virtually nil. Therefore the CVS plus is suitable only for use with motors/suction pumps which are safe to run 'shut-off' or which incorporate vacuum relief devices.

6) OPERATION

6.1) Suction. Before using the equipment make sure that the hoses are fully inserted into the manifold and that the filter is clean and in place. Selecting a hose from its holder will provide suction at all three hoses, the amount of which can be varied by means of the thumbwheel on each tip connector as indicated in the diagram below. Moving the valve anti-clockwise, as indicated by the arrow, will result in a reduction of suction. When the slot is at right angles to the valve body, suction is virtually shut-off.

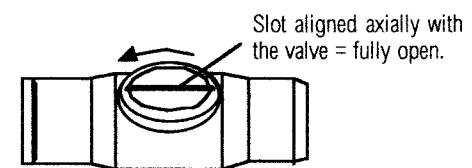
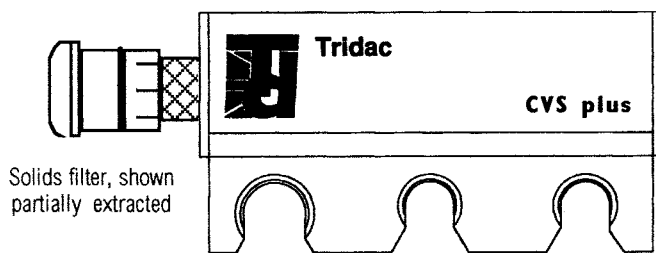

6.2) Attachment of accessories

The suction tip connectors will accept a range of standard tips designed for 16 mm and 11 mm fittings. Tips are simply a push fit into the connectors, which include an 'O' ring to grip the tip and seal the connection.

Adaptors are available for converting the 16 mm connector to 11 mm and for reducing the 11 mm size to accept commonly available disposable saliva ejectors.

Note: The 16 mm to 11 mm adaptor can usefully increase flow rate through medium sized tips (approx. 8.0 mm dia.) by allowing use in the large operating hose. Furthermore, the larger suction hose is less prone to obstruction by solids particles, like lumps of amalgam.

7) ROUTINE CLEANING AND MAINTENANCE

7.1) General. Disconnect the electrical supply to the unit when cleaning is undertaken, unless instructed that the suction must run.

Wear suitable protective clothing when cleaning dental equipment. We recommend a face mask, eye protection and strong rubber gloves, household rather than surgical, as there is a danger that the latter could be easily split or punctured.

If cleaning detachable parts by brush and assuming the parts may be immersed, do so in a bowl or sink filled with the chosen cleaning solution. Keep items submerged while brushing, to eliminate splashing.

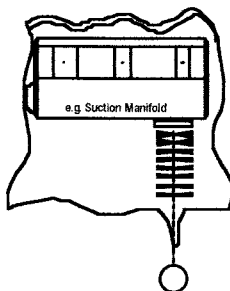

Where parts are not detachable or submersible, polythene bags can be used to contain spatter. Inexpensive quality, domestic food bags are quite suitable. The bag may be pierced to allow the handle of the brush through, then wrapped tightly around it. Alternatively, the brush may be placed inside and the handle gripped through the bag.

Soiled brushes may be cleaned in a bowl of detergent and may be soaked in disinfectants suitable for use with metal. We suggest using a little of the aspirator cleaner made up for the treatment of the suction hoses.

7.2) Rinsing In normal use, it is frequently the case that only small quantities of secretions, such as spray and saliva, are aspirated. These secretions tend to be sticky and often contain fine particles of solids from drilling operations.

When fanned by the high air flow rates occurring inside the suction tubings, the secretions tend to dry out, leaving stubborn deposits. The internal condition of hoses and other parts contacted by aspirated secretions can be improved by keeping the internal bores rinsed. To do this, we recommend flushing used operating hoses after each patient, by aspirating a tumbler of water. See section below, for hints on flushing.

7.3) Flushing. Aspiration equipment should be flushed at least once a day with a specialist NON FOAMING disinfectant cleaner(3).

BEWARE: Not all non foaming cleaners live up to that claim!

Also avoid bleach and cleaners based on aldehydes.

Since freshly deposited secretions are easier to shift and disinfectants are less effective, or ineffective, on heavily soiled parts, we recommend carrying out a first flush with plain water. This is also much cheaper than specialist aspirator cleaners! Follow up with with the disinfectant product.

Make up 1.0 litre of the aspirator cleaner to the manufacturer's recommended dilution. Remove, empty and replace the solids filter. (see section 7.4).

Suck the solution in equal quantity through each of the operating hoses that has been used. Do so by holding the suction tip only partially submerged, as indicated in the diagram. This allows a turbulent mixture of liquid and air to enter the tube, which gives a greater cleaning effect and longer exposure time.

Lift the hose occasionally to position B. This helps heavy sediments, like amalgam, to be flushed through. These might otherwise fail to be lifted from deep droops in the hose such as A.

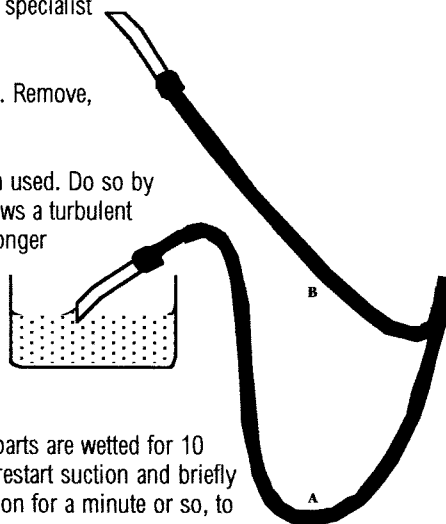

Stop the suction as soon as the flushing solution has been used up, so that internal parts are wetted for 10 minutes or so to allow disinfectant action, without the drying effect of air flow. Then restart suction and briefly lift the hoses, as at B, to dispose of any remaining sediments. Now leave the suction on for a minute or so, to reduce any remaining liquid inside the manifold.

7.4) Solids filter. Solids filters should be checked regularly. The frequency of emptying will depend on the type of use the suction has been put to. We suggest checking the filter in the middle of and at the end of the working day. A full or clogged filter will reduce suction flow rates and put additional strain on the suction pump and should not be neglected.

The filter is a stainless steel sleeve of 0.7 mm mesh and is carried by a plastic holder, which avoids direct handling. Pull the filter from the side cheek of the manifold housing and empty it by tipping the accumulated contents into your contaminated waste receptacle.

Ensure that the the 'O' ring seal, filter holder and bore of the manifold (see section 7.6) are clear of deposits to ensure a seal when the filter is replaced.

Clean the filter in a bowl (see section 7.1) if the mesh pores become clogged. Note that air flow is in to the end and out through the surface as indicated by the arrows. Thus brushing the mesh from the outside will displace trapped debris. After cleaning, the 'O' ring seal should be lubricated with a little silicone grease.

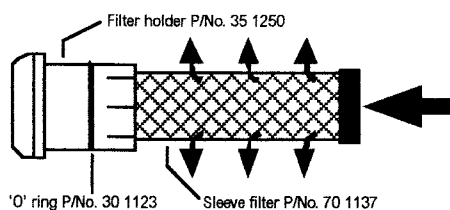

The filter mesh, but NOT the holder, may be autoclaved after cleaning, if required. Remove the sleeve by tilting gently to the side and pulling. Use moderate force to avoid damaging the holder.

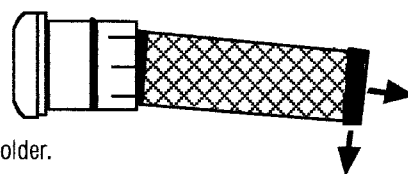

7.5) Operating hoses. These should be cleaned daily to maintain clean external and internal surfaces and free bores.

Operating hoses are supplied as a plug in set which is easily detached from the manifold. The 'manifold connector' is gripped by an 'O' ring seal fitted inside the manifold. The hose set is detached by a straight downward pull on the connector. Do not pull on the hoses. The manifold connector and the bore of the manifold itself must be kept clean to ensure a seal when the hose set is refitted.

Hose sets should be cleaned after the flushing operation described in section 7.3). They may be immersed in detergent solution for cleaning and should be cleared of debris at the tip connectors and manifold connector by using the brushes provided. Subsequently they can be soaked in aspirator cleaner / disinfectant(3), if desired.

After cleaning, the manifold connector should be smeared with a little silicone grease on the surface which enters the manifold. This will lubricate the manifold fitted 'O' ring. Do not over lubricate or the 'O' ring may lose its grip. Wipe off excess from both parts if this occurs.

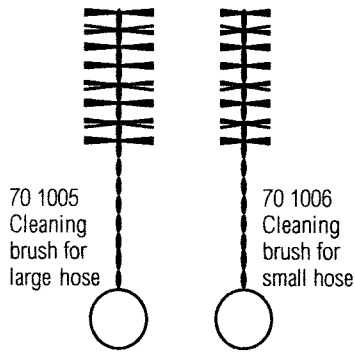

The rotary valves and their sealing 'O' rings must also be maintained regularly. Silted valves will soon become stiff and difficult to rotate. The valves are a snap fit into the body parts, see diagram, and are simply pulled from the body.

The valves are a close fit in the body and both parts must be kept thoroughly clean to assist reassembly and smooth operation. Lubricate the 'O' rings before reassembly. Introduce the valve to the body as squarely as possible to

allow entry. To complete assembly, align the recess over the stop screw, then press the centre of the valve with the thumb until it is felt to 'snap' back into place.

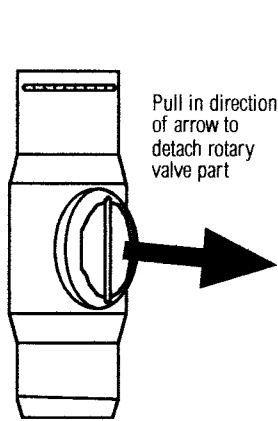
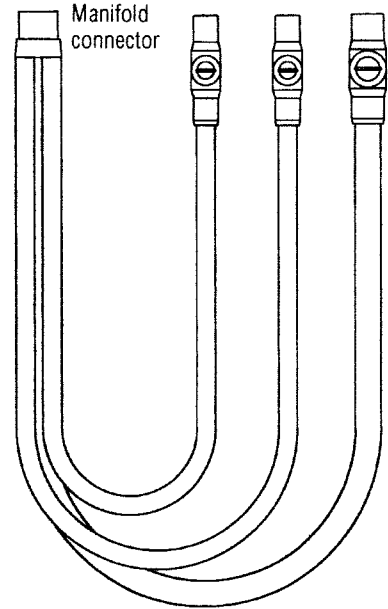

P/No. 22 1284 Large Rotary Tip Assembly
P/No. 22 1285 Small Rotary Tip Assembly

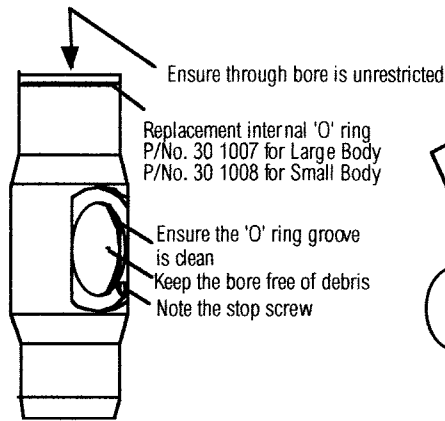

P/No. 35 1241 Rotary Tip Body, Large
P/No. 35 1242 Rotary Tip Body, Small

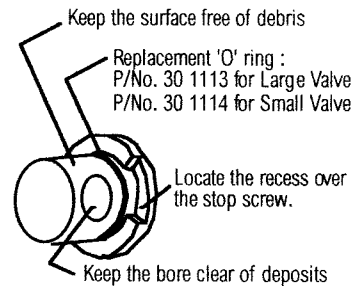

P/No. 35 1243 Rotary Valve, Large
P/No. 35 1244 Rotary Valve, Small

7.6) Manifold air ways. These should be kept clean and clear of blockages. Blocked air ways will reduce suction performance and place extra strain on the suction pump, which could lead to over heating. Clean bores A and B at least once a week. Bore C may be more difficult to access, depending on installation, but should be cleaned at least once a month.

Good access to bores A and B is obtained when the hose set and solids filter are removed. Use the cleaning brush provided to ensure clear passages. After brushing, ensure that the bores, including the 'O' ring at the entry B, are wiped clean.

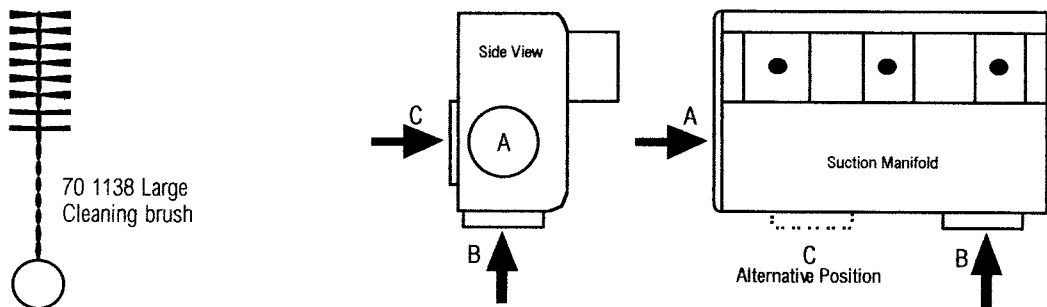

Access to bore C may be from behind the mounting panel/surface on which the manifold has been installed.

Bore C should be cleaned at least once a month. Pull the plastic hose coupling from the bore and again use the large cleaning brush to clear debris. Ensure that the internal surface and 'O' ring inside entry C are wiped clean before refitting. Smearing the coupling with silicone grease before reinsertion will ensure that the 'O' ring gets lubricated.

7.7) Aspirator tips The CVS plus is supplied without tips. Users should follow the manufacturer's instructions for cleaning and sterilisation of any tips in use. Reusable tips should be cleaned and sterilised after each patient.

Tridac metal tips are available as listed in the spares section of this booklet. These are chromium plated and may be sterilised by autoclave many times without deterioration. The plastic spray interceptor (16 mm fitting) P/No. 60 1101 is also autoclavable but must be expected to deteriorate after fewer cycles.

Tips should be washed in detergent and the bores brushed (see section 7.1). Use brush 70 1005 or 70 1006, appropriate to the bore of the tip. Reserve these brushes for tip cleaning only : do not use them for other jobs. Rinse the tips thoroughly after cleaning.

Once cleaned the tips can be autoclaved at 134 to 138 degrees C for 3 minutes.

7.8) Cleaning materials.

DO NOT use bleach. Ensure products are suitable for use on metals. Ensure aspirator cleaners DO NOT FOAM under vacuum.

The following products have been tested and are recommended. Similar products may also be suitable but should be tested first.

- 1) External surface cleaning : Household detergents such as washing-up liquid.
- 2) External surface disinfection : 'Formal Spray' surface disinfectant, by Courtin Ltd.
'Mikrozid AF' surface disinfectant, by Schulke & Mayr.
- 3) Aspirator cleaner : 'TriDDAClens' by Tridac.
'Oratol plus' by Durr Dental.

8) THIRD PARTY MAINTENANCE There is no recommended programme of routine preventative maintenance. If cared for as instructed in section 7) the product should give lasting satisfaction.

9) SPARE PARTS REFERENCES

Part No.	Description/Comment
60 1038	Tip connector adaptor, 11 mm to disposable saliva ejector (approx. 6.0 mm dia.)
22 1231	Tip connector reducer, 16 mm to 11 mm
22 1284	Complete rotary tip connector assembly, large
22 1285	Complete rotary tip connector assembly, small
22 1338	Operating hose set, less rotary tip connectors, with manifold connector
30 1007	Tip seal 'O' ring, large tip connectors
30 1008	Tip seal 'O' ring, small tip connectors
30 1110	Manifold 'O' ring, entries B & C
30 1113	Rotary valve 'O' ring, large
30 1114	Rotary valve 'O' ring, small
30 1123	Filter holder 'O' ring
35 1250	Filter holder
60 1013	Small surgical tip, metal (3.6 mm Bore)
60 1014	Large surgical tip, metal (7.0 mm Bore)
60 1016	Saliva ejector/Tongue guard, metal.
60 1101	Spray interceptor tip, flanged, plastic
70 1005	5/8" Cleaning brush
70 1006	1/4" Cleaning brush
70 1137	Sleeve filter
70 1138	1" Cleaning brush
70 1200	'TriDDAClens Super' aspirator cleaner

PARTS DIAGRAM for CVS Plus Suction Manifold

Models :- 22-1167, 22-1211, & 22-1306

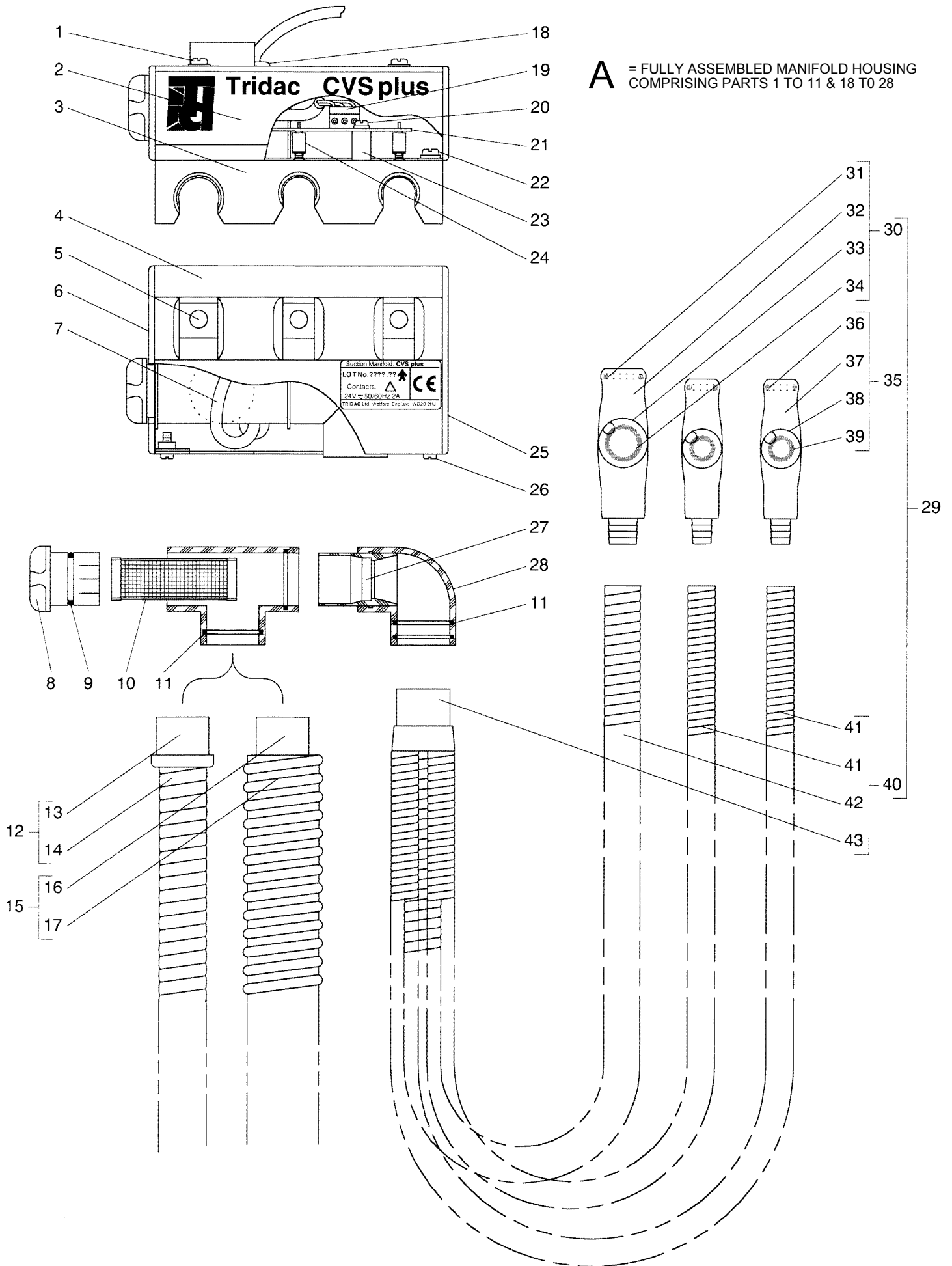

LEGEND FOR PARTS DIAGRAM

Item	Part No.	Description	Item	Part No.	Description
1	65-1310	M5 x 10 Pan head screw	21	20-1032	P.C.B. Assembly, S/P
	65-2708	M5 Shakeproof Washer		20-1033	P.C.B. Assembly, D/P
2	75-1106	Facia Label	22	65-1310	M5 x 10 Pan head screw
3	22-1321	Hanger Block assy. S/P		65-2708	M5 Shakeproof Washer
	22-1322	Hanger Block assy. D/P	23	35-1290	Spacer
	45-1487	Hanger Block + items 20,21,23 & 24	24	10-1258	MicroSwitch
4	40-1708	Front Cover (Items 2, 6 & 25 also req'd)	25	35-1246	End Plate
5	35-1074	Actuating ball	26	65-1274	M4 x 10 Pan head screw
6	35-1245	End Plate	27	35-1249	Filter Locator
7	15-1136	4 Core Cable, std length 2.4mtr.	28	35-1234	Elbow } Supplied together
8	35-1250	Filter Holder	29	22-1302	Hose Set, complete with valves
9	30-1123	'O' Ring	30	22-1284	Large Rotary Valve Assembly
10	70-1137	Sleeve Filter	31	30-1007	'O' Ring
11	30-1110	'O' Ring x 2	32	35-1241	Large Valve Body
12	22-1495	Hose assembly. Wetline	33	35-1243	Large Valve
13	35-1257	Hose Adaptor	34	30-1113	'O' ring
14	32-1064	Hose. 19mm ID. std length 2.4mtr.	35	22-1285	Small Rotary Valve Assembly
15	22-1496	Hose Assembly. Dryline or semi dry	36	30-1008	'O' Ring
16	35-1236	Hose Adaptor	37	35-1242	Small Valve Body
17	32-1012	Hose. 32mm ID. std length 2.4mtr.	38	35-1244	Small Valve
18	10-1084	Grommet	39	30-1114	'O' Ring
19	10-1256	3 way Connector	40	22-1338	Hose Set, Replacement
20	65-1292	M4 x 20 Pan head screw	41	32-1062	Small Hose. Std length 1.5m
	65-2739	M4 Nylon washer	42	32-1063	Large hose. std length 1.5m
A	22-1490	Complete Manifold Housing assembly	43	35-1233	Manifold Connector

OPTIONAL HAND SPITTOONS, ASPIRATION TIPS AND ADAPTORS for use with the TRIDAC CVS Plus MANIFOLD or any EUROPEAN SIZED SUCTION SYSTEMS

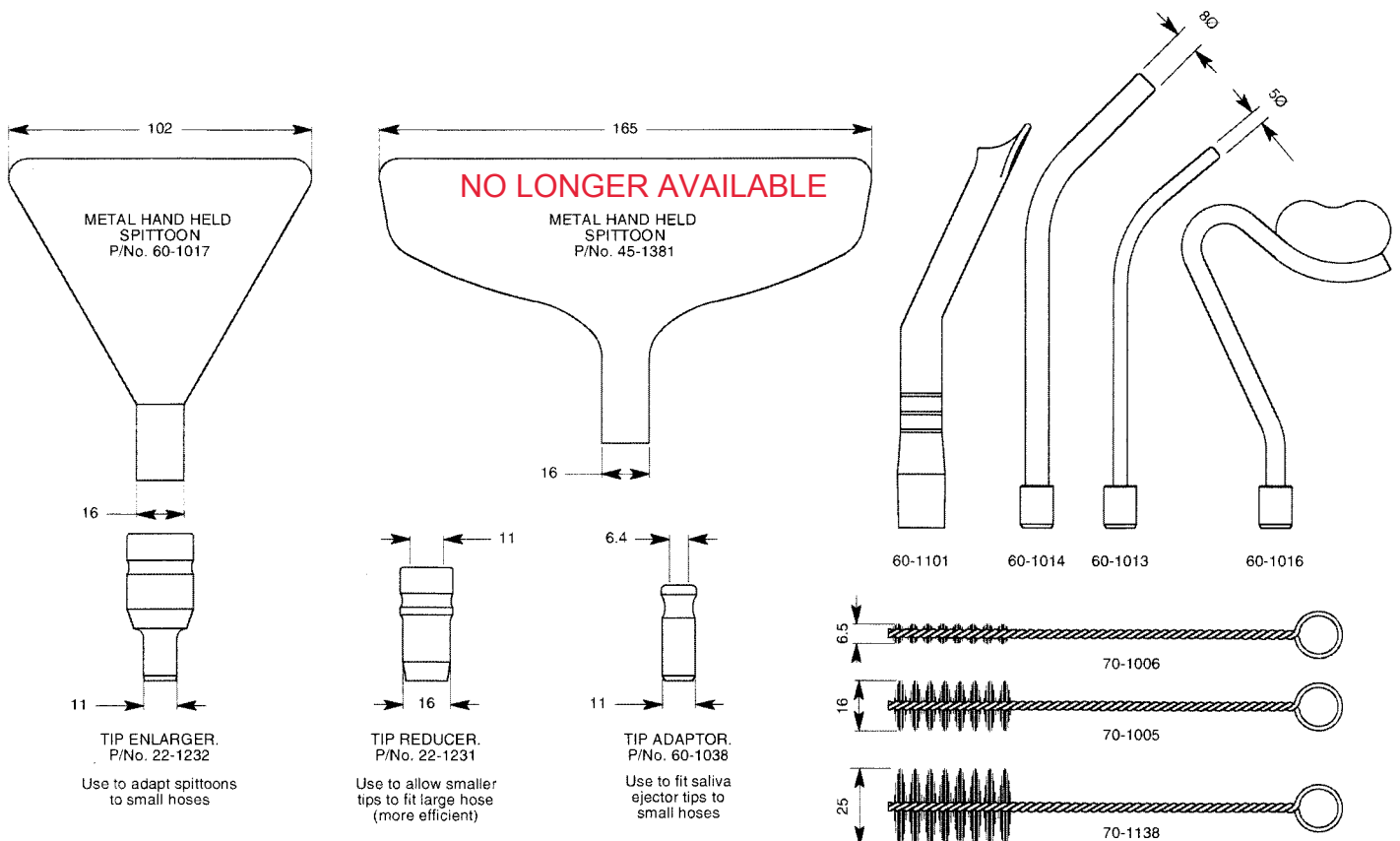

WIRING SCHEMATICS : TRIDAC CVS Plus SUCTION MANIFOLDS PART NUMBERS 22 1167, 22 1211 & 22 1306

RECOMMENDED WIRING SCHEMES WITH 24 V A.C. SOLENOIDS AND RELAYS
Items external to the suction manifold are shown for indication only. They are not supplied.
Appropriate fusing and protection of the mains circuit should be ensured.
The low voltage transformer should comply with the requirements of BS EN 60601-1 and should not exceed a nominal secondary voltage of 25 V a.c.

