

FEATURES & BENEFITS

QUALITY CONTROL

Eye/face wash and valve assembly is pre-built and fully water/pressure tested to ensure no leaks and proper function which ultimately reduces installation time and gives the end contractor an added peace of mind. Unit also ships with green molded ABS plastic wall bracket to assist in the installation process.

VALVES

Eye/face wash and shower ball valves are designed to make the flushing of fluid remains occur with the simple pull of a lever or push of a stainless steel flag.

SAFETY

8" x 10-3/4" (20.3 x 27.3 cm) universal emergency sign make the unit easily detected in an emergency. Test card to record weekly checks helps maintain the unit's best working quality.

EYE/FACE WASH

AXION® MSR eye/face wash head uses an inverted directional laminar flow to sweep contaminants away from the vulnerable nasal cavity.

OPTIONS

- ❑ Scald Protect Bleed Valve: Model SP157A, stainless steel scald protection bleed valve. Automatic thermal actuator bleed valve opens when internal water temperature reaches 98° F (36.7° C) and closes at 95° F (35° C).
- ❑ Thermostatic Mixing Valve: Model 9201EW AXION® Emergency Tempering Valve thermostatically mixes hot and cold water to provide a safe fluid supply for a single emergency eye/face wash, with a flow rate of 10 gpm (38.8 L).
- ❑ Emergency Alarm System : Model 9001.5, 1/2" 120 VAC emergency alarm and light system. Buzzer and flashing light are activated by a 1/2" IPS double pole, double throw flow switch.
- ❑ Thermostatic Mixing Valve: Model 9201EFE AXION® Emergency Tempering Valve thermostatically mixes hot and cold water to provide a safe fluid supply for a single emergency eye/face wash, with a flow rate of 12 gpm (38.8 L).

For more information, visit www.hawsco.com or call (888) 640-4297.



SPECIFICATIONS

Model 7324 wall mounted eye/face wash shall include an AXION® MSR eye/face wash head shall feature inverted directional laminar flow which achieves Zero Vertical Velocity™ supplied by an integral 3.7 gpm flow control. Unit shall also include a chrome-plated brass stay-open ball valve equipped with stainless steel ball and stem, green molded ABS plastic wall bracket, universal sign, and 1/2" NPT inlet. Note: Floor drain is recommended for this unit.

APPLICATIONS

Where the eyes and face of any person may be exposed to injurious or corrosive materials, suitable facilities for quick flushing of the eyes and face must be provided within the work area for immediate emergency use. Emergency eye/face wash facilities shall be in unobstructed and accessible locations that require no more than 10 seconds for the injured person to reach. Model 7324 is certified by CSA to meet the ANSI Z358.1 Standard for Emergency Eyewash and Shower Equipment.

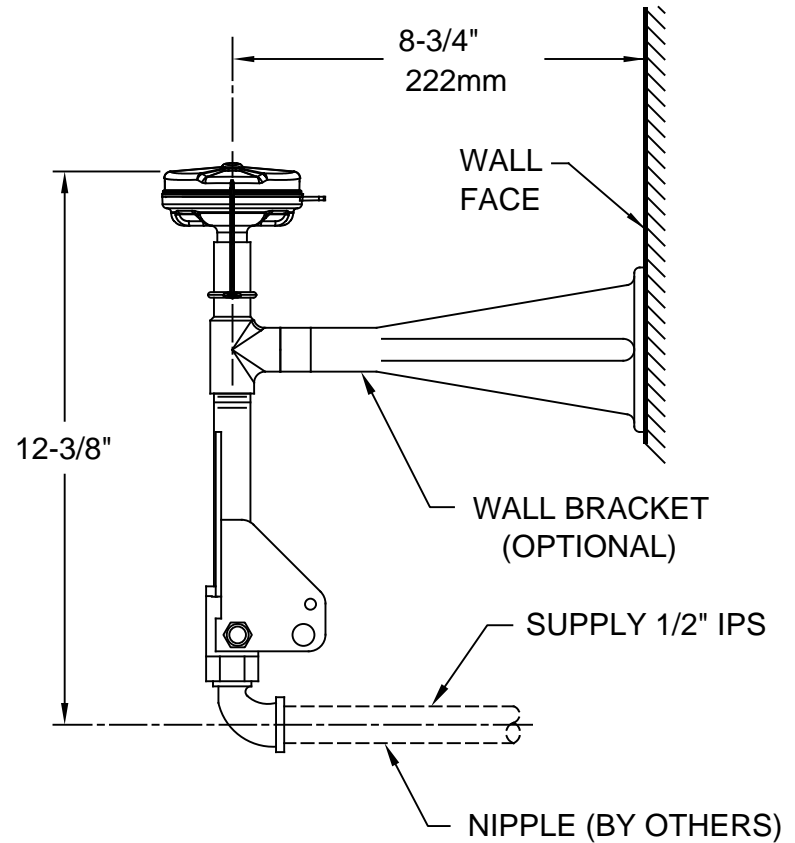
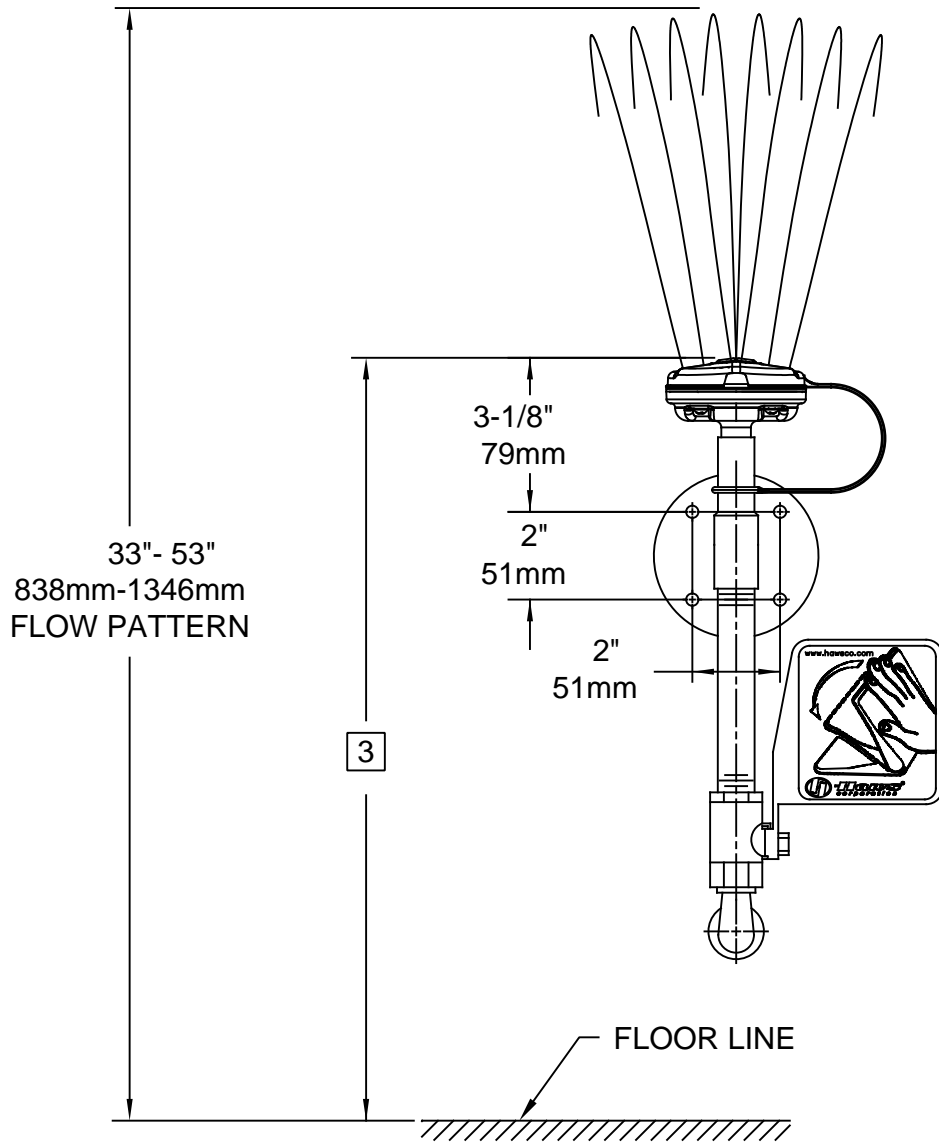

NOTES:

1. WHEN INSTALLING THIS UNIT, LOCAL, STATE, OR FEDERAL CODES SHOULD BE ADHERED TO FOR INSTALLATION DIMENSIONS (LOCATIONS), WASTE AND SUPPLY REQUIREMENTS OTHER THAN SHOWN.
2. TO COMPLY WITH ANSI Z358.1-2014 FOR EMERGENCY EYEWASH OR EYE/FACE WASH: EYEWASH OR EYE/FACE WASH SHALL BE POSITIONED SUCH THAT FLUSHING FLUID PATTERN IS NOT LESS THAN 33" (838mm) AND NO GREATER THAN 53" (1346mm) FROM SURFACE ON WHICH USER STANDS; AND 6.0" (153mm) MINIMUM FROM WALL OR NEAREST OBSTRUCTION.
3. HEIGHT IS DETERMINED BY WATER FLOW PATTERN HEIGHT SHOWN, WHICH IN TURN, IS DEPENDENT ON IN-LINE SUPPLY PRESSURE.
4. DIMENSIONS MAY VARY BY ±1/2" (13 mm).

		1455 KLEPPE LANE SPARKS, NEVADA 89431 (775) 359-4712 FAX (775) 359-7424 E-MAIL: HAWS@HAWSOCO.COM WEBSITE: WWW.HAWSOCO.COM	
		ECN NO. REVISED PER BY: MODEL(S) ECN: 5175 VWC	PART NUMBER 0002080068.D
DRAWN: CH DATE: 05/91	CHECKED: VWC DATE:	7324	REVISION 10
APPROVED: FV DATE: 11/23/17	SCALE: NA	DRAWING TYPE: INSTALLATION	SIZE: A SHEET 1 OF 1