

- cUPC Certified
- Serves One to Three Users at a Time
- Unique, Repairable, Solid Surface Material
- Highly Vandal Resistant
- Saves Water, Energy and Space
- ADA/TAS Compliant

## Specifications

### Size and Capacity

Accommodates 1-3 users at a time, using less water, energy and space than three lavs equipped with conventional faucets. The pre-assembled sprayhead module is equipped with three independent streamformers, each controlled by a separate push button or infrared sensor.

### Flow Control/Rate

Operating water pressure range is 20–80 psi. Flow regulators keep flow rate constant at all pressures. A flow restrictor keeps the flow rate at constant a .5 GPM under any pressure.

## Construction

### Bowl and Pedestal

Constructed of Terreon®, a densified solid surface material composed of polyester resin, or Terreon®RE, a densified solid surface material composed of a bio-based resin and preconsumer recycled granules. Terreon and TerreonRE are resistant to chemicals, stains, burns and impact. Surface damage can be easily repaired with everyday cleansers or fine grit abrasives. Terreon and TerreonRE are NAHB certified to meet ANSI Z124.3, Z124.6 and ANSI/ICPA SS-1-2001. Terreon and TerreonRE are GREENGUARD® certified as low-emitting materials. Pedestal frame and access panels are constructed of heavy gauge type 304 stainless steel.

### Vandal Resistance

The molded sprayhead is an integral element of the bowl module. All streamformers, escutcheons and push buttons/infrared sensors are secured to the unit from inside the sprayhead module. All valves, water supplies and waste connections are concealed inside the pedestal. The front access panel is removable only with a hex key. The Terreon and TerreonRE bowls are resistant to stains, burns and impact. Surface damage is easily repaired and repair work is virtually undetectable.

## Standard Equipment

### Valves and Fittings

In addition to the bowl and pedestal, the following valves and fittings are standard: Navigator® thermostatic mixing valve, stop valves, drain spud, flexible stainless steel supply hoses. Stop valves mount onto 1/2" nominal copper tubing.

## Activation Controls

### Air Valve Hand Control

Each push button pneumatically actuates a non-hold-open, air metering, single-temperature valve with field adjustable timing from 0–45 seconds. Factory preset at 10 seconds. Each push button activates one valve which, in turn, activates one station. Push button requires less than five pounds of pressure.

### Infrared Control

Each of the stream formers is controlled by a separate solenoid valve. Hands placed within the bowl are detected by an infrared sensor which activates a flow of tempered water from one station. Shut-off is automatic after hands are removed from the detection area. The infrared sensor uses a conical-shaped transmitting beam, having a detection area adapted to, but not exceeding, the bowl perimeter. The adaptive infrared sensor automatically adapts to the bowl after power is turned on. The infrared sensor is not affected by varying color tones or darkness. Direct sunlight or bright washroom lights will not activate the system. Infrared models also include solenoid valves and a low-voltage transformer as standard equipment:

- Solenoid – 24V, 50/60 Hz, 5/16" tube fitting. Few moving parts, and resistant to most chemicals, minerals, and impurities often present in municipal water supplies.
- Low-Voltage Transformer – Class II UL/CSA listed, 110/24 VAC plug-in transformer. Plugs into a standard GFCI protected electrical outlet. Location of transformer per local electrical code.

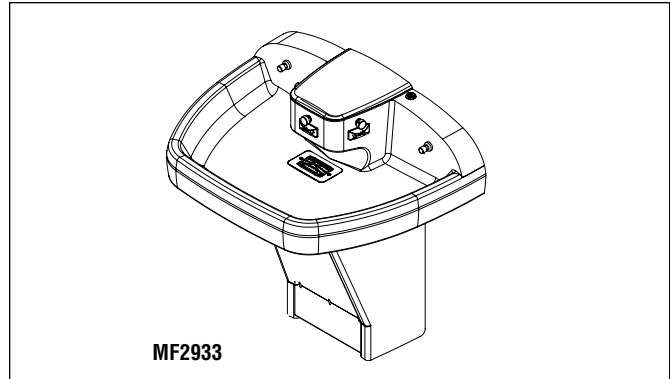
**MF2933**

### Battery Infrared Control

Each battery-powered sensor uses a zone-focused infrared transmitting beam, creating a large detection area not exceeding the bowl perimeter. The sensor is not affected by varying skin tones or darkness. When hands enter the detection area, the sensor starts water flow by opening the solenoid valve electronically. When hands leave the detection area, the sensor stops the flow of water by closing the valve. The 6-volt DC electronically activated solenoid valve has few moving parts, providing reliable operation that is unaffected by most chemicals and minerals often present in municipal water supplies. Each station is powered by a single lithium battery. Battery type is Duracell® DL 223A or equivalent (included). Battery type is Duracell® DL 223A 6 volt lithium or equivalent with a life expectancy of 4-5 years or approximately 200,000 cycles.

### TouchTime® Hand Control

Each low-voltage button actuates a non-hold-open, slow-closing anti-hammer solenoid valve that is timed from an electronic potted assembly. Each push button activates one valve which, in turn, activates one station. TouchTime controls water flow at each station through the use of solid state, digital circuitry. Timing is electronically controlled at 15 seconds. Push button requires less than five pounds of pressure.

## Code Compliance and Certifications

### ANSI Standards

Terreon and TerreonRE are certified by NAHB certified to meet ANSI Z124.3, Z124.6 and ANSI/ICPA SS-1-2001.

### cUPC Approval

Terreon Washfountains are Uniform Plumbing Code (UPC), International Plumbing Code (IPC) and National Plumbing Code of Canada (NPC) approved through the International Association of Plumbing and Mechanical Officials (IAPMO). Manufactured in compliance with IGC 156-2009, CSA B45 Series-2002 (R08) & ASME A112.18.1-2005/CSA B125.1-2005.

### Barrier-Free

The standard height Tri-Fount is designed to comply with the most current ADA and TAS guidelines on reaches, clearances and operation when mounted at standard height dimensions by the installer. JUV Height selection does not meet ADA or TAS. For JUV ADA or TAS select MF2939 or MF2949.



Standard product selections contained within this document are third party **CERTIFIED** to NSF/ANSI 372 meeting the Lead-Free content requirement. Any product configured with custom options will be **COMPLIANT** with NSF/ANSI 372 meeting the Lead-Free content requirement.



<b>Standard Selections</b> (Must select one from each category)			
<b>Pedestal Height (select one)</b>			
<input type="checkbox"/> <b>STD</b>	Standard Height 34" Rim		
<input type="checkbox"/> <b>JUV</b>	Juvenile Height 30" Rim		
<input type="checkbox"/> <b>OBC</b>	Ontario Building Code Height		
<b>Valves (select one)</b>			
<input type="checkbox"/> <b>IR</b>	Adaptive Infrared	<input type="checkbox"/> <b>BIR3</b>	Battery Infrared
<input type="checkbox"/> <b>AST</b>	Air Metering	<input type="checkbox"/> <b>TT</b>	Touchtime® Metering
<b>Soap Dispenser (select one)</b>			
<input type="checkbox"/> <b>LSD</b>	Liquid Soap Dispenser	<input type="checkbox"/> <b>NSD</b>	No Soap Dispenser
<b>Color of Terreon Bowl (select one)</b>			
<i>Standard Colors</i>			
<input type="checkbox"/> <b>CHAR‡</b>	Charcoal Gray	<input type="checkbox"/> <b>O-TAUPE</b>	Organic Taupe
<input type="checkbox"/> <b>COBBLE</b>	Cobblestone	<input type="checkbox"/> <b>PEBBLE</b>	Pebble Beach
<input type="checkbox"/> <b>DRIFT†</b>	Driftwood	<input type="checkbox"/> <b>PEP-WHT</b>	Peppered White
<input type="checkbox"/> <b>DUNE†</b>	Sand Dune	<input type="checkbox"/> <b>SAND</b>	Sandtrap
<input type="checkbox"/> <b>E-GRAY</b>	Empire Gray	<input type="checkbox"/> <b>S-CREEK</b>	Stone Creek
<input type="checkbox"/> <b>GRAPH‡</b>	Graphite	<input type="checkbox"/> <b>S-MIST</b>	Silver Mist
<input type="checkbox"/> <b>LANNON</b>	Lannonstone	<input type="checkbox"/> <b>WHT-SAND</b>	White Sand
<input type="checkbox"/> <b>LONDON</b>	London Gray		
<input type="checkbox"/> <b>MOONSTONE†</b>	Moonstone		
<i>Designer Colors** (available at an additional charge)</i>			
<input type="checkbox"/> <b>ARC-CHIP</b>	Arctic Chip	<input type="checkbox"/> <b>RIVER</b>	Riverstone
<input type="checkbox"/> <b>COFFEE</b>	Coffee Bean		
<i>TerreonRE Colors** (available at an additional charge)</i>			
<input type="checkbox"/> <b>BIRCH-BARK</b>	Birch Bark	<input type="checkbox"/> <b>MOONDUST</b>	Moondust
<input type="checkbox"/> <b>DUSK</b>	Dusk	<input type="checkbox"/> <b>OAT</b>	Oat
<b>Supply (select one)</b>			
<input type="checkbox"/> <b>TL</b>	Single tempered Line		
<input type="checkbox"/> <b>TMA</b>	Navigator® Thermostatic Mixing Assembly (Hot & Cold Supplies)		

\*\*Non-cancellable, non-returnable.  
†This color contains large, randomly distributed chips.  
‡ Requires tempered supply (less than 110°F) or optional TMA

**Dimensions - Standard and Juvenile Height (mm)**

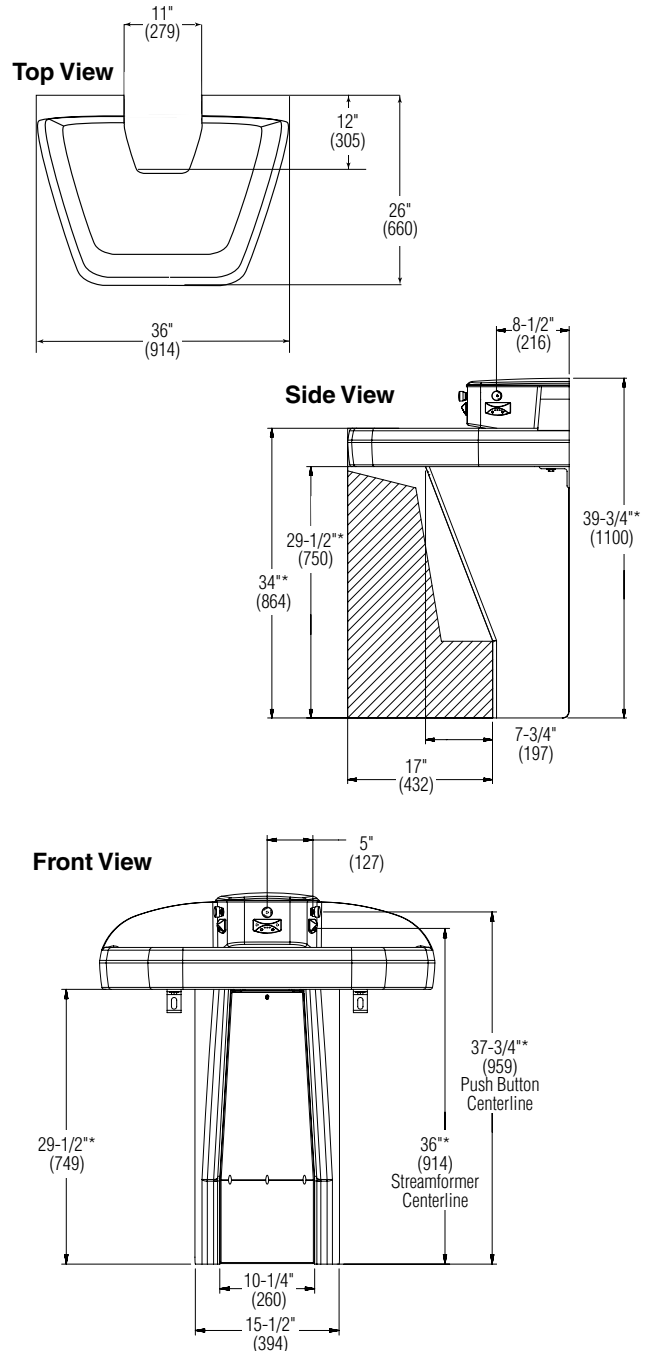

\* Subtract 1" from these dimensions for Ontario Building Code height or 4" for Juvenile Height Model.

### Rough-Ins

(mm)

### Wall or Floor

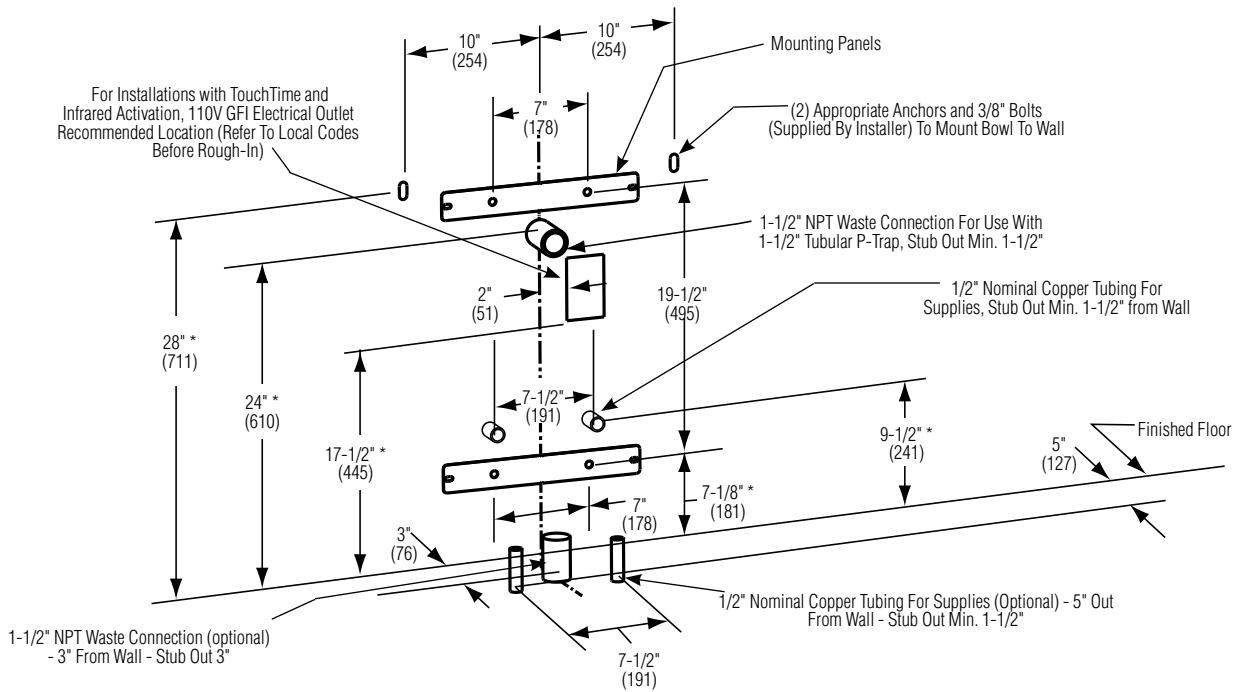

\* Subtract 1" from these dimensions for Ontario Building Code height or 4" for Juvenile Height Model.