

- ADA Compliant External Temperature Control
- Reliable Infrared Activation
- Adjustable Operating Modes
- Vandal Resistant Cast Brass Spout
- Chrome-Plated Finish
- Above-Deck Water-Tight Electronics
- 6V Lithium Battery Operation (Battery Included)
- 12V AC Transformer Available (Not Included)

Standard Equipment

Infrared Sensor

The IR Sensor uses a twin-beam system to respond quickly when needed, and to eliminate false activations. The electronics can be adjusted between static mode sensing the complete IR beam and dynamic mode sensing only hand motion.

Valve

The electronically activated solenoid valve provides reliable performance since there are few moving parts and its operation is unaffected by most chemicals and minerals found in municipal water supplies. The faucet includes (2) stainless steel supply hoses with check stops to prevent backflow into the supply lines.

Flow Control/Rate

Operating range 20–80 PSI. The vandal-resistant aerator produces a .5 GPM flow rate. A 2.2 GPM laminar flow control is also included.

Faucet Body

Chrome-plated solid cast brass body. Centershank mounting with optional 4" centerset trim plate available.

Sanitary

No-touch operation reduces water/soap splatter and addresses the public's increasing awareness and concern about communicable diseases.

Vandal Resistant

The sensor module, circuit board and solenoid valve are enclosed in the solid cast brass faucet body. The faucet also features a vandal-resistant aerator.

Code Compliance and Certifications

CSA

The 1100 Series High Arc Faucets are certified to meet CSA B125 test standards for plumbing fixtures. The faucets are CSA approved in Canada and the United States.

ASME A112.18.1

The 1100 Series High Arc Faucets are certified to meet the ASME A112.18.1 standard for plumbing fixtures.

ADA Compliance

The infrared sensor produces a broad detection zone that allows disabled users to easily activate the faucet from either a front or side approach; the external temperature control does not require tight grasping or rotating and turns on less than 5 pounds of pressure, meeting ADA guidelines provided by ANSI A117-1.

Verify all rough-in dimensions prior to installation.
 Consult local and national codes. Conformity and compliance to local and national codes is the responsibility of the installer.

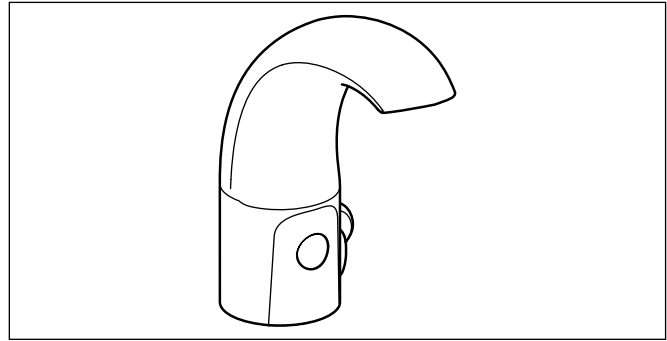

Check Your Surroundings

Certain factors, such as intense direct sunlight, other infrared devices, or other site conditions may interfere with the activation of infrared faucets. Contact your Bradley Representative to discuss any application concerns.

Sample Specification

No-touch infrared faucet shall be (S53-329) Bradley Aerada™ 1100 Series High Arc IR Faucet. The faucet shall be powered by a 6-volt DC lithium battery (included). All Electronics shall be above deck within watertight enclosure. The external temperature control shall be constructed of solid cast brass and shall comply with ADA guidelines. The faucet shall include a chrome-plated, forged brass body with centershank mounting, .5 GPM vandal-resistant aerator and (2) stainless steel flexible supply hoses. The faucet shall be UPC approved and certified to CSA standards.

Models	
Faucet Only:	
<input type="checkbox"/> S53-328	AC High Arc IR Faucet Centershank
<input type="checkbox"/> S53-329	DC High Arc IR Faucet Centershank

Optional Selections	
Trim Plate:	
<input type="checkbox"/> 150-221	4" Chrome-plated trim plate
Transformer:	
<input type="checkbox"/> 232-008	Plug-in Transformer 12V
<input type="checkbox"/> 232-009	Hardwire Transformer 12V (1–8 Faucets)
Flow Control:	
<input type="checkbox"/> 269-1922	2.2 GPM Laminar Flow Control
Drain Assembly:	
<input type="checkbox"/> 269-1231	D-ASSY, Drain, Strainer, and Tailpiece

Standard product selections contained within this document are third party **CERTIFIED** to NSF/ANSI 372 meeting the Lead-Free content requirement. Any product configured with custom options will be **COMPLIANT** with NSF/ANSI 372 meeting the Lead-Free content requirement.



(mm)

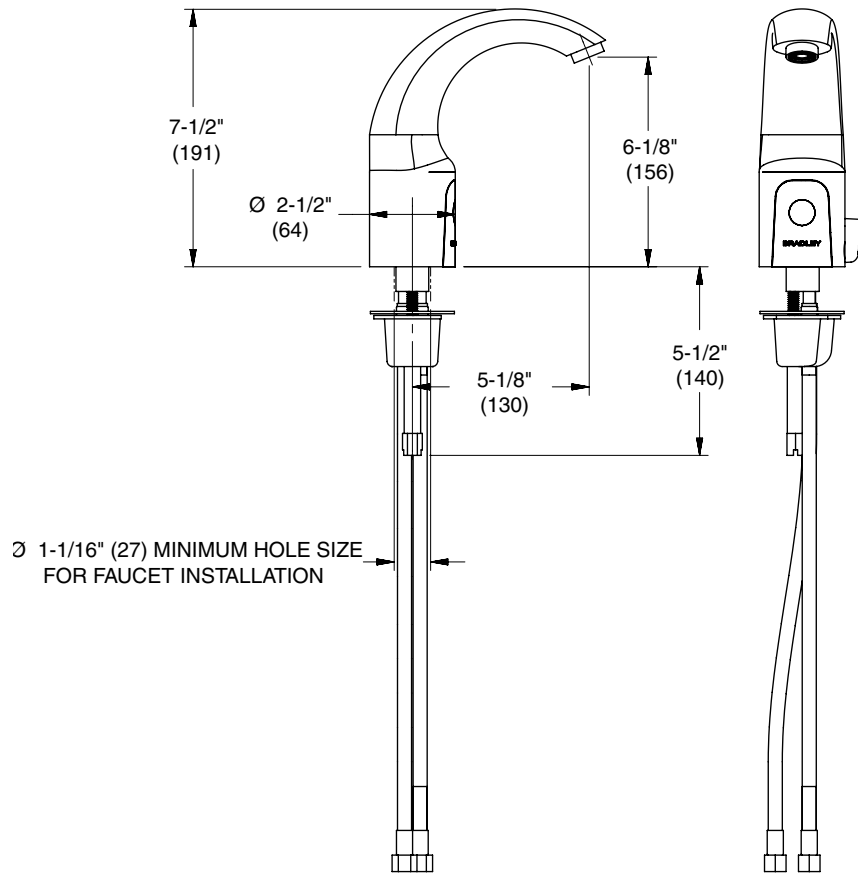

Verify all rough-in dimensions prior to installation.
 Consult local and national codes. Conformity and compliance to
 local and national codes is the responsibility of the installer.