

# Technical Pro

Professional Karaoke Amplifier

with USB & SD Card & Bluetooth Inputs

User Manual for:

MM2000BT

## WARNING!

**CAUTION: TO REDUCE THE RISK OF ELECTRIC SHOCK, DO NOT REMOVE THE COVER OF THIS UNIT. THERE ARE NOUSER-SERVICEABLE PARTS INSIDE. REFER ALL SERVICING TO A QUALIFIED TECHNICIAN.**



The lightning flash with arrowhead symbol within an equilateral triangle is intended to alert the user to the presence of "dangerous" voltage within the product's enclosure that may be of sufficient magnitude to constitute a risk of electric shock to humans. Users should exhibit extra safety when this symbol appears in this instruction manual and follow all precautions as they are stated.



The exclamation point within an equilateral triangle is intended to alert the user to the presence of important operating and maintenance (servicing) instructions in this manual.

- 1- Read these instructions thoroughly before using this item.
- 2- Keep these instructions for future reference.
- 3- Heed all warnings.
- 4- Follow all instructions.
- 5- **WARNING:** To prevent fire or electric shock, do not expose this equipment to rain or moisture. Do not store or operate this product near any liquids.
- 6- Clean only with a dry cloth.
- 7- Do not store or operate this product near any heat sources such as radiators, heat registers, stoves, or other apparatuses (including amplifiers) that produce heat.
- 8- Do not defeat the safety purpose of the polarized or grounding-type plug. A polarized plug has two blades with one wider than the other. A grounding plug has two blades and a round grounding prong. The wide blade or third prong is provided for your safety. If the provided plug does not fit your outlet, consult an electrician for the replacement of the obsolete outlet.
- 9- Protect the all wires connected to this unit from being walked on or pinched, particularly plugs and the point where they exit from the unit. When removing the cord from the power outlet, remove it by holding the plug not by pulling the cord.
- 10- Unplug the unit during lightning storms or when unused for long periods of time.
- 11- When wiring this unit and all other equipment used in connection to this unit make sure that all of your equipment is turned OFF.
- 12- Once installation and wiring is complete power on all your equipment with the volume and level controls turned DOWN. Once all the equipment is ON slowly raise the volume or level controls to their proper positions.
- 13- When grounding this unit, be sure to do so correctly, so as not to defeat the built-in grounding in this unit.
- 14- Before placing, installing, rigging, or suspending any product, inspect all hardware, suspension, cabinets, transducers, brackets and associated equipment for damage. Any missing, corroded, deformed, or non-load rated component could significantly reduce the strength of the installation, placement or array. Any such condition severely reduces the safety of the installation and should be immediately corrected. Use only hardware which is rated for the loading conditions of the installation and any possible short-term, unexpected overloading. Never exceed the rating of the hardware or equipment.
- 15- Consult a licensed, Professional Engineer regarding physical equipment installation. Ensure that all local, state and national regulations regarding the safety and operation of equipment are understood and adhered to.
- 16- Refer all servicing to qualified service personnel. Servicing is required when the apparatus has been damaged in any way, such as power supply cord or plug is damaged, liquid has been spilled or objects have fallen into the apparatus, the apparatus has been exposed to rain or moisture, does not operate normally, or has been dropped.

## Introduction

Congratulations and thank you for your purchase of this Technical Pro professional karaoke amplifier, the MM2000BT. To get the most from your MM2000BT, it is recommended that you review all of the information provided in this instruction manual before operating this equipment.

If you've spent any time at all in professional audio, you know the name Technical Pro and what it stands for — incredible performance & sound, and the ultimate in reliability under harsh conditions. And now, Technical Pro offers the same technology in a series of karaoke amplifier bringing more of what sets Technical Pro apart from all others.

## MM2000BT Front Panel

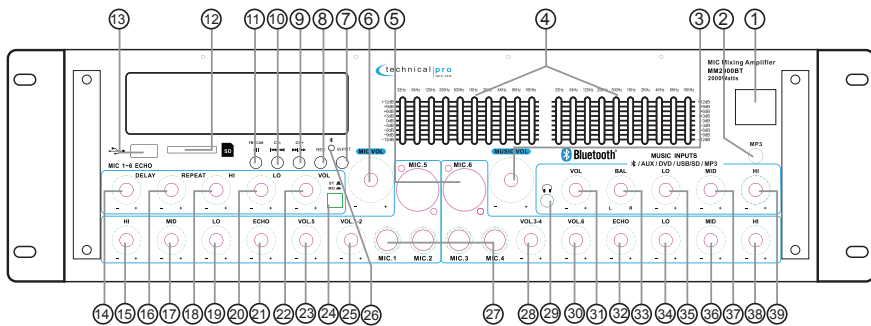

**1. Power Button:** Press this button to power the unit on and off.

**2. MP3(1/8") Input:** Connect your MP3 player or computer here. Make sure to press the input selector button (7) until "MP3" appears on the display screen to play the signal from the MP3 player or computer.

**3. Line Volume:** Turn this knob to adjust the volume of music.

**4. Dual Ten Band Equalizers:** Use the sliders to increase or decrease the signal strength of the respective frequencies. The equalization points are 32Hz, 64Hz, 125Hz, 250Hz, 500Hz, 1KHz, 2KHz, 4KHz, 8KHz and 16KHz.

**5. XLR Microphone Inputs (Balanced):** Connect balanced microphone to these inputs.

**6. Microphone Volume:** Use this knob to adjust the volume of the microphones.

**7. Input Selector:** Use this button to switch between all the inputs.

**8. Recording from the AUX / MP3 / DVD and Microphone Inputs:**

### **HOW TO MAKE A RECORDING**

When the input selected is MP3/AUX/DVD and there is a USB flash drive or SD card (with blank space on it) inserted into their respective slot, pressing and holding this button will activate the recording function. Press this button and hold for several seconds and the word "REC" will display on the screen. The unit will create a new file in the connected USB flash drive or SD card and get ready to make a recording. At this point there is no actual recording yet. Press the button again and the unit will start recording onto the USB flash drive or SD Card and the elapsed time and "REC" will display on the screen. Press the button a third time to pause the recording and the word "REC" and the elapsed time displayed on the screen will start flashing. Press again to continue the recording. Press and hold this button for several seconds to save the file and end the recording and exit. If both USB flash drive and SD card are connected, the unit will begin recording onto the USB flash drive. If the USB flash drive is full, remove it and then press the record button again to start another recording. The unit will also be able to record the signal from microphones onto the USB flash drive or SD Card. When the recording function is activated and there is a microphone connected to the unit, the unit will mix the signal from MP3 or AUX inputs with the microphone into one track. If two microphones are connected and turned on, both microphone signals will be recorded and mixed into one track with the signal from MP3, AUX or DVD inputs.

**THERE IS NO RECORDING FUNCTION WHEN INPUT SELECTED IS USB/SD, BLUETOOTH OR FM TUNER. THE RECORDING FILE FORMAT IS .mp3.**

**9. Next Track / Fast Forward / Next Preset Station Button:**

**When playing from the USB/SD/Bluetooth inputs:** Press this button to go to the beginning of the next track on either the USB flash drive, SD Card or Bluetooth input. Press this button and hold for several seconds to fast forward. The unit will keep fast forwarding until this button is released. This function only works for USB flash drive or SD Card signal.

**When playing from the Tuner input:** Press this button to go to the next station stored station.

**10. Previous Track / Fast Rewind / Previous Preset Station Button:**

**When playing from the USB/SD/Bluetooth inputs:** Press this button to go to the beginning of the previous track on either the USB flash drive, SD Card or Bluetooth input. Press this button and hold for several seconds to fast rewind. The unit will keep fast rewinding until this button is released. This function only works for USB flash drive or SD Card signal.

**When playing from the Tuner input:** Press this button to go to the previous station stored station.

**11. Play / Pause / Scan Button:**

**When playing from the USB/SD inputs:** Press this button to pause the signal from the USB flash drive, SD card connected to the USB input. Press this button again to play. The play / pause function will only work for the USB flash drive, SD card or Bluetooth.

**When playing from the Tuner input:** Press this button to make the unit scan all the available stations from lowest frequency to the highest frequency. The unit will automatically save all the stations searched and start to play the first station saved after searching. You can press the NEXT button (9) or PREV button (10) to go to the next or previous saved station.

**12. SD Card Input:** Insert your SD card into this slot. The unit will only read .mp3, .wma files from SD card. The maximum storage size of the SD card cannot exceed 32GB. Make sure to set the input selector button to "SD CARD" to play the signal from the SD Card. When the unit is playing tracks from the SD Card the track and elapsed time will display on the screen.

**13. USB Input:** Insert your USB flash drive or iPod™ (Classic and Nano) into this slot. The unit will only read .mp3, .wma files from the USB flash drive or iPod™ (Classic and Nano). The maximum storage size of the USB flash drive cannot exceed 32GB. Make sure to set the input selector button (7) to "USB" to play the signal from the USB flash drive or iPod™ (Classic and Nano). When the unit is playing tracks from the USB flash drive the track and elapsed time will display on the screen.

**14. Microphone Echo Delay Control:** Use this knob to adjust the delay effect of the echo of microphone signal.

**15. Group 1 Microphone Treble Control:** Use this knob to adjust the treble of the Group 1 (mics 1,2 & 5) microphone signal output.

**16. Microphone Echo Repeat control:** Use this knob to adjust the repeat effect of the echo of microphone signal.

**17. Group 1 Microphone Mid Control:** Use this knob to adjust the mid level frequencies of the Group 1 (mics 1,2 & 5) microphone signal output.

**18. Microphone Echo Treble Control:** Use this knob to adjust the treble of the echo of microphone signal.

**19. Group 1 Microphone Bass Control:** Use this knob to adjust the bass of Group 1 (mics 1,2 & 5) microphone signal output.

**20. Microphone Echo Bass Control:** Use this knob to adjust the bass of the echo of microphone signal.

**21. Group 1 Microphone Echo Control:** Use this knob to adjust the echo of Group 1 (mics 1,2 & 5) microphone signal output.

**22. Echo Volume Control:** Use this knob to adjust the volume of echo of microphone signal.

**23. MIC 5 Volume Control:** Use this knob to adjust the volume of MIC 5.

**24. Stereo/Mono Switch:** Press this button to switch between stereo & mono for microphone echo.

**25. MIC 1 & MIC 2 Volume Control:** Use this knob to adjust the volume of MIC 1 & MIC 2.

**26. Bluetooth Indicator:** This Bluetooth indicator will remain illuminated when there is a Bluetooth device connected to the MM2000BT. It will turn off if there is no Bluetooth connection.

**27. Microphone Inputs:** Microphone Inputs ¼".

**28. MIC 3 & MIC 4 Volume Control:** Use this knob to adjust the volume of MIC 3 & MIC 4.

**29. Headphone Output:** Connect your headphone here. Make sure the volume level of the unit is turned down before making the connection.

**30. MIC 6 Volume Control:** Use this knob to adjust the volume of MIC 6.

**31. Line Input Volume Control:** Use this knob to adjust the volume of line input signal.

**32. Group 2 Microphone Echo Control:** Use this knob to adjust the echo of Group 2 microphone signal output.

**33. Balance Control of Line Input:** Use this knob to adjust the balance of line input signal.

**34. Group 2 Microphone Bass Control:** Use this knob to adjust the bass of Group 2 (mics 3,4 & 6) microphone signal output.

**35. Bass Control of Line Input:** Use this knob to adjust the bass of line input signal.

**36. Group 2 Microphone Mid Control:** Use this knob to adjust the mid level frequencies of the Group 2 (mics 3, 4 & 6) microphone signal output.

**37. Mid Control of Line Input:** Use this knob to adjust the mid level frequencies of line input signal.

**38. Group 2 Microphone Treble Control:** Use this knob to adjust the treble of the Group 2 (mics 3,4 & 6) microphone signal output.

**39. Treble Control of Line Input:** Use this knob to adjust the treble of line input signal.



## MM2000BT Rear Panel

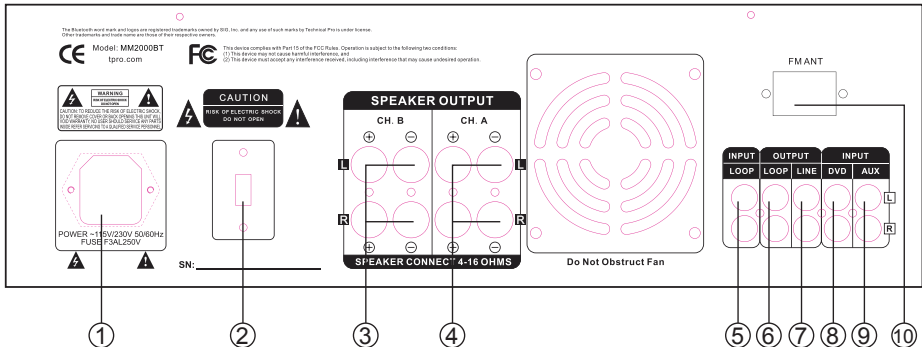

**1. Power Supply:** Only use the power cord provided with the unit to power the unit. When connecting and disconnecting the power cord, be sure the power of the unit is off. Connect the cord to the rear of the unit and then connect it to the outlet.

**2. Voltage selector:** Select between 230V AC 50Hz / 115V AC 60Hz. When using with a 115V outlet, the unit should be set to 115V.

**3. Group B Main Speakers:** Connect your main speakers to these speaker outputs. The unit should be powered off and volume levels turned down when making these connections.

**THE MM2000BT OPERATE MOST EFFICIENTLY WHEN USED WITH 8 OHM SPEAKERS.**

**4. Group A Main Speakers:** Connect your main speakers to these speaker outputs. The unit should be powered off and volume levels turned down when making these connections.

**THE MM2000BT OPERATE MOST EFFICIENTLY WHEN USED WITH 8 OHM SPEAKERS.**

**5. Loop Input:** Connect the output of a separate equalizer to the loop input. This equalizer should be the same one which "Loop Output" is connected to. If not, there won't be any volume output from the speakers.

**6. Loop Output:** Connect the loop output to a line input on a separate equalizer. If there is no equalizer needed, plug in the plug provided with the unit to enable this function. If there is no equalizer connected to this output and the plug isn't plugged, there won't be any volume output from the speakers connected.

**7. Line Outputs:** Connect the line output to either a recording device, another amplifier or a powered (active) subwoofer. The signal from the line output is a passive output and cannot be connected directly to a passive speaker.

**8. DVD Input:** Connect any stereo signal output such as a DVD, CD, TAPE, Mixer etc to this input. To play a signal connected to this input make sure the MP3 input is selected on the front panel.

**9. AUX Input:** Connect any stereo signal output such as a DVD, CD, TAPE, Mixer etc to this input. To play a signal connected to this input make sure the AUX input is selected on the front panel.

**10. FM Antenna:** Connect your FM antenna here.

## Typical MM2000BT Input and Output Connections

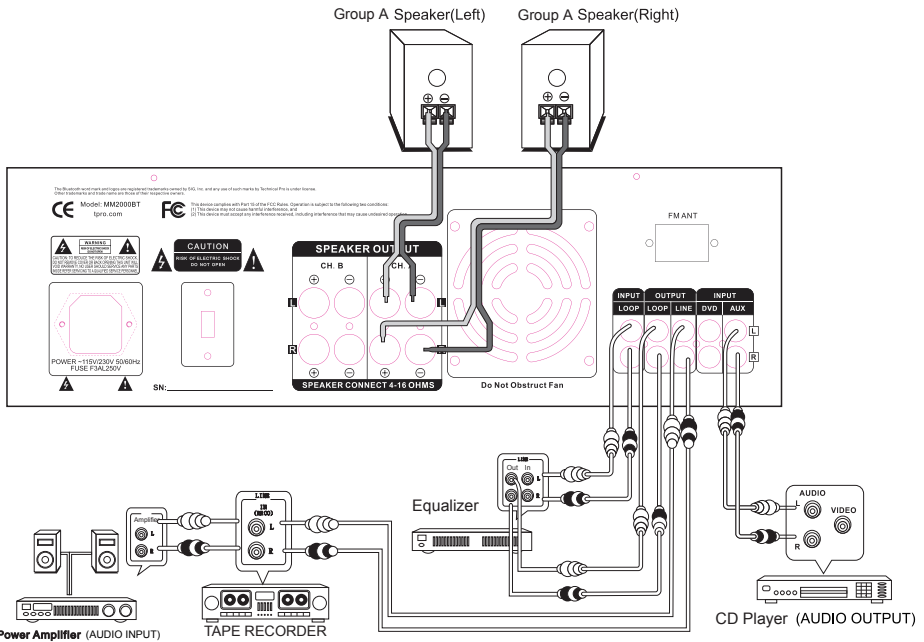

### Connecting a Bluetooth Device to the MM2000BT

To play tracks from the iPhone™ (or other Bluetooth device) on MM2000BT via Bluetooth, first press the "INPUT" button on the front panel to select the Bluetooth input mode. Then turn on the Bluetooth function on iPhone™ and search for compatible Bluetooth devices. The MM2000BT is named "TPRO MM2000BT". Find the MM2000BT, then pair and connect to it. The LED indicator for Bluetooth connection will remain illuminated if there is a device connected to MM2000BT via Bluetooth. It will turn off if there is no Bluetooth connection.

The MM2000BT has two groups of full range loudspeakers which will play either the signal from either the DVD, USB Flash Drive, SD Card, Bluetooth, MP3, AUX and FM Tuner.

The **LINE OUTPUT** is connected to the input of a tape recorder. You can also connect the LINE OUTPUT directly to the input of another amplifier. The LINE OUTPUT will send the signal from the selected input (DVD, USB Flash Drive, SD Card, Bluetooth, MP3, AUX and FM Tuner).

The **Loop Output** is connected to an equalizer which will have the signal processed and send back to the MM2000BT via Loop Input. If there is no equalizer needed, you can also Loop IN / Out EQ Plugs provided with the unit.

The **Loop Input & Output terminals** on the rear panel of MM2000BT are for connecting to a separate equalizer. The Loop Output should be connected to the input of the equalizer. Then the output from the equalizer should be connected to the **Loop Input**. If there is no equalizer connected to the MM2000BT, the EQ plugs packed with the unit must be plugged into the Loop Input and Output jacks like the diagram above. Otherwise there won't be any volume output from the speakers.

**NOTE: MM2000BT WILL ONLY BE DISCOVERABLE WHEN ITS INPUT IS SET TO "BLUETOOTH". WHEN MAKING THESE CONNECTIONS THE POWER OF THE MM2000BT AND THE SIGNAL SOURCE SHOULD ALL BE IN THE OFF POSITION WITH THE VOLUME LEVELS TURNED DOWN.**

### Connecting the speaker wire to the MM2000BT's main speaker outputs

1. Remove approximately 10 mm (0.4 in) of insulation from the end of each speaker cable and twist the exposed wires of the cable together to prevent short circuits.

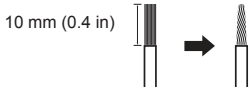

2. Unscrew the main speaker output terminal on the rear of the MM2000BT. Insert the exposed speaker wire into the opening.

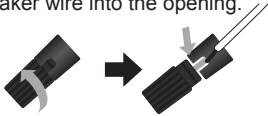

3. Tighten the knob.



### Connecting the EQ plugs to the MM2000BT's Loop Input & output

The Loop Input & Output jacks on the rear panel of MM2000BT are for equalizer. The Loop Input should be connected to the output of the equalizer and the Loop Output should be connected to the input of this same equalizer. If there is no equalizer connected to the MM2000BT, the EQ plugs packed with the unit must be plugged into the Loop Input and Output jacks like the diagram below. Otherwise there won't be any volume output from the speakers.

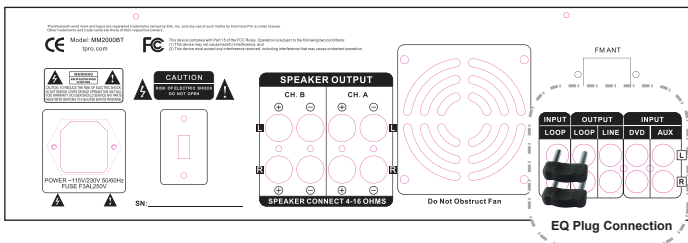

### EQ Plug



**NOTE: WHEN MAKING THESE CONNECTIONS THE POWER OF THE MM2000BT AND THE SIGNAL SOURCE SHOULD ALL BE IN THE OFF POSITION WITH THE VOLUME LEVELS TURNED DOWN.**

## USB Flash Drive & SD Card & iPod™ (Classic and Nano)

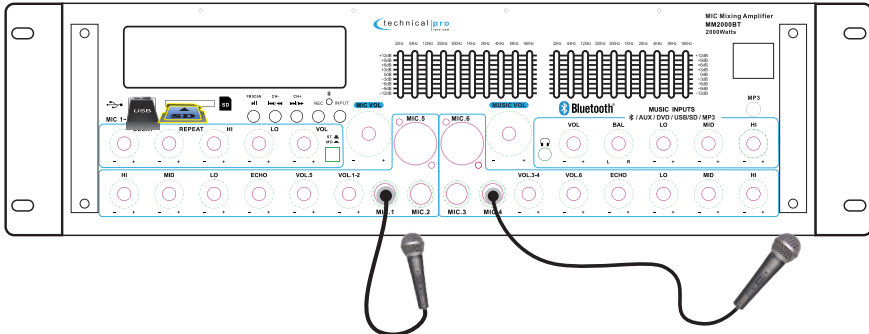

There are also SD Card and USB flash drive inputs on the front panel of the MM2000BT which is compatible with iPod™ (Classic and Nano) via the USB input. The maximum size of the SD Card or USB flash drive is 32GB. If your memory card exceeds 32GB, the unit will not be able to read the files from the memory cards. You will only be able to play .mp3, .wma files directly from these memory cards once they are inserted into the front panel of the unit. Press the play/pause button on the front panel of the unit to begin playing files from your USB /SD Card, press this button again to pause. Press the NEXT button to move to the next track on either the USB,SD Card or iPod™ (Classic and Nano). Press the PREVIOUS button to move to the previous track on either the USB,SD Card or iPod™ (Classic and Nano) .

**NOTE: THE USB INPUT WILL ONLY CONNECT TO A USB FLASH DRIVE OR iPod™ (Classic and Nano). DO NOT ATTEMPT TO CONNECT THE USB INPUT DIRECTLY TO A COMPUTER AS THIS WILL NOT WORK. BE SURE NOT TO HOOK-UP AN AMPLIFIER OR ANY AMPLIFIED SIGNAL INTO THE RCA INPUT JACK AS THIS COULD DAMAGE THE MM2000BT. NO OTHER AMPLIFIER IS NEEDED TO POWER YOUR SIGNAL IN ADDITION TO THE MM2000BT. ALWAYS MAKE SURE THAT THERE IS ONLY ONE AMPLIFIER IN THE SIGNAL PATH.**

### Programming the FM Tuner

Set the input to Tuner. Then press the Play / Pause button to scan for all the available stations from lowest frequency to the highest frequency. The unit will automatically save all the stations searched and start to play the first station saved after searching. You can press the NEXT button (9) or PREV button (10) to go to the next or previous saved station.

### Connecting Microphones to MM2000BT

There are four 1/4" inputs on the face of the unit which you can plug microphones directly into. It is important to note that these inputs are to be used solely by microphones. Do not attempt to use the 1/4" inputs for any other use. To use, simply plug the microphones into the 1/4" inputs while the speaker and microphones are in the OFF position. Once plugged in, power on the unit and microphones. Once turned on, simply turn up the Microphone Volume and the Master Volume. There are also two XLR inputs on the face of the unit which you can input balanced signal from.

### Volume and Tone Controls

The volume controls on the face of the unit controls the volume at which the signal is played at. Turn the volume controls clockwise to increase the volume and counter-clockwise to decrease the volume.

### Microphone Controls

The six microphone inputs have many options which can be controlled on the front panel of the unit. The microphone volume controls can be found on the front panel of the unit. Use these controls to adjust the volume of the microphones. Each group microphone inputs has six sound controls on the front panel of the unit, a treble control, a middle tone control, a bass control, an echo control, a volume control for XLR input and a volume control for 1/4" inputs. Use these controls to adjust the sound from the microphones.

## AC Power Cord Connection

To connect the power cord to your MM2000BT simply plug female side of the power cord into the power cord input which is on the rear of the unit. Then plug the male side of the power cord to an electric outlet. The AC power cords supplied purposefully have 2 blades and one grounding prong. If your outlet is not equipped to handle this type of plug, do not attempt to forcefully plug this AC power cord into the outlet, and do not alter the plug so that it can fit in the outlet. The only course of action you can take is to find another outlet which is properly equipped to handle a grounded plug or have an electrician upgrade your electrical outlet. Be sure that the plug is well connected so that it does not disconnect in the middle of usage. If at any point in time the supplied AC power cord is punctured or damaged replace it with a new power cord from a local electrician.

**NOTE: ONLY PLUG IN THE AC POWER CORD WHILE THE UNIT'S POWER IS OFF AND THE VOLUME IS TURNED DOWN. TURNING ON THE UNIT WITH THE VOLUME TURNED UP MAY CAUSE THE UNIT OR ANY SPEAKERS CONNECTED TO IT TO BE DAMAGED. ALWAYS TURN DOWN THE VOLUME PRIOR TO TURNING OFF THE UNIT.**

## Input / Output Connections

### Connecting the Signal Source to the MM2000BT(DVD/MIXER/MP3 etc.)

The unit has four RCA input jacks on the rear of the unit which is designed to receive the signal directly from your CD, mixer or any of your other sources. To ensure that you have correctly connected your CD player (other sound sources) to the unit, make sure that the CD player has a RCA cord coming from its output and that this cord is plugging into the RCA Input on the rear of the MM2000BT.

**NOTE: BE SURE NOT TO CONNECT AN AMPLIFIER OR ANY AMPLIFIER SIGNAL INTO THE RCA INPUT JACKS. AS THIS COULD DAMAGE THE MM2000BT. NO OTHER AMPLIFIER IS NEEDED TO POWER YOUR SIGNAL IN ADDITION TO THE MM2000BT. ALWAYS MAKE SURE THAT THERE IS ONLY ONE AMPLIFIER IN THE SIGNAL PATH.**

There are also input jacks for USB flash drive and SD card on the front panel of the MM2000BT which is compatible with iPod™(Classic and Nano) via the USB input. Just plug the USB flash driver, SD card or iPod™(Classic and Nano) into their respective input jacks and set the MM2000BT to the corresponding input. Be sure that the volume of the MM2000BT are turned down at first and then slowly raise the volume to prevent damage the speakers or any of your other equipment.

### Connecting the MM2000BT to Passive Loudspeakers

The MM2000BT is designed to power up to two groups of full-range passive loudspeakers. The speakers should be connected via the speaker wire outputs on the rear of the MM2000BT.

**NOTE: WHEN MAKING THESE CONNECTIONS THE POWER OF THE MM2000BT AND THE SIGNAL SOURCE SHOULD ALL BE IN THE OFF POSITION WITH THE VOLUME LEVELS TURNED DOWN. ONCE THE UNITS ARE ALL POWERED ON, SLOWLY INCREASE THE VOLUME TO AVOID DAMAGING ANY OF YOUR EQUIPMENT. THE MM2000BT OPERATE MOST EFFICIENTLY WHEN USED WITH 8 OHM SPEAKERS.**

## Accessories

Power Cord, User Manual, Warranty, FM Antenna, EQ Plug.

iPod™ & iPhone™ are registered trademarks of Apple Computers, Inc. Apple Computers, Inc. is not endorsing, sponsoring, or otherwise affiliated with this manufacturer.

## Screen Display

USB

USB

This will display when the unit is reading the USB flash drive.

SD CARD

SD CARD

This will display when the unit is reading the SD card.

MP3

MP3

This will display when the input selected is MP3.

005 508

005 508

This will display when the unit is playing tracks from USB flash drive or SD card. The track No. is 5 and the elapsed time is 5min 8sec.

REC 004

REC 004

This will display when the unit is recording and the elapsed time is 4seconds. When the recording is paused this will flash on the screen.

ROCK

ROCK

This will display when the equalizer is set to ROCK.

VCD/CD

VCD/CD

This will display when the input selected is VCD/CD.

NO DISK

NO DISK

This will display when the unit is playing from USB flash drive or SD card without any tracks inside.

FM 98.3

FM 98.3

This will display when the unit is playing FM tuner and station frequency is 98.3MHz.

PREV

PREV

This will display when pressing the "Previous" button or key.

NEXT

NEXT

This will display when pressing the "Next" button or key.

VOL 31

VOL 31

This will display when the volume level is set to 31.

PAUSE

PAUSE

This will display when the playing is paused.

POP

POP

This will display when the equalizer is set to POP.

CLASS

CLASS

This will display when the equalizer is set to CLASS.

JAZZ

JAZZ

This will display when the equalizer is set to JAZZ.

BLUETOOTH

Bluetooth

This will display when the input selected is bluetooth.

The Bluetooth word mark and logos are registered trademarks owned by SIG, Inc. and any use of such marks by Technical Pro is under license. Other trademarks and trade name are those of their respective owners.

**THIS DEVICE COMPLIES WITH PART 15 OF THE FCC RULES. OPERATION IS SUBJECT TO THE FOLLOWING TWO CONDITIONS:**

- (1) THIS DEVICE MAY NOT CAUSE HARMFUL INTERFERENCE AND
- (2) THIS DEVICE MUST ACCEPT ANY INTERFERENCE RECEIVED, INCLUDING INTERFERENCE THAT MAY CAUSE UNDESIRE OPERATION.

### Federal Communications Commission Requirements

The equipment has been tested and found to comply with the limits for Class B Digital Device, pursuant to part 15 of the FCC Rules. These limits are designed to provide reasonable protection against harmful interference in a residential installation. This equipment generates uses and can radiate radio frequency energy and, if not installed and used in accordance with the instruction, may cause harmful interference to radio communication. However, there is no guarantee that interference will not occur in a particular installation. If this equipment does cause harmful interference to radio or television reception, which can be determined by turning the equipment off and on, the user is encouraged to try to correct the interference by one or more of the following measures:

- Reorient or relocate the receiving antenna.
- Increase the separation between the equipment and receiver.
- Connect the equipment into an outlet on a circuit different from that to which the receiver is connected.
- Consult the dealer or an experienced radio/TV technician for help.

**THE CHANGES OR MODIFICATIONS NOT EXPRESSLY APPROVED BY THE PARTY RESPONSIBLE FOR COMPLIANCE COULD VOID THE USER'S AUTHORITY TO OPERATE THE EQUIPMENT.**

### FCC Radiation Exposure Statement

The equipment complies with FCC radiation exposure limits set forth for uncontrolled equipment and meets the FCC radio frequency (RF) Exposure Guidelines in Supplement C to OET65. The equipment has very low levels of RF energy that it is deemed to comply without testing of specific absorption ratio (SAR).