



User Manual for:
Professional DJ Multicolor LED
Stage Effect light With DMX

MODEL: LG500x

WARNING!

CAUTION: TO REDUCE THE RISK OF ELECTRIC SHOCK, DO NOT REMOVE THE COVER ON THIS SPEAKER. THERE ARE NO USER-SERVICEABLE PARTS INSIDE. REFER ALL SERVICING TO A QUALIFIED TECHNICIAN

 The lightning flash with arrowhead symbol within an equilateral triangle is intended to alert the user to the presence of "dangerous" voltage within the product's enclosure that may be of sufficient magnitude to constitute a risk of electric shock to humans. Users should exhibit extra safety when this symbol appears in this instruction manual and follow all precautions as they are stated.

 The exclamation point within an equilateral triangle is intended to alert the user to the presence of important operating and maintenance (servicing) instructions in this manual.

- 1- Read these instructions thoroughly before using this item.
- 2- Keep these instructions for future reference.
- 3- Heed all warnings.
- 4- Follow all instructions.
- 5- **WARNING:** To prevent fire or electric shock, do not expose this equipment to rain or moisture. Do not store or operate this product near any liquids.
- 6- Clean only with a dry cloth.
- 7- Do not store or operate this product near any heat sources such as radiators, heat registers, stoves, or other apparatuses (including amplifiers) that produce heat.
- 8- Do not defeat the safety purpose of the polarized or grounding-type plug. A polarized plug has two blades with one wider than the other. A grounding plug has two blades and a round grounding prong. The wide blade or third prong is provided for your safety. If the provided plug does not fit your outlet, consult an electrician for the replacement of the obsolete outlet.
- 9- Protect the all wires connected to this unit from being walked on or pinched, particularly plugs and the point where they exit from the unit. When removing the cord from the power outlet, remove it by holding the plug not by pulling the cord.
- 10- Unplug the unit during lightning storms or when unused for long periods of time.
- 11- When wiring this unit and all other equipment used in connection to this unit make sure that all of your equipment is turned OFF.
- 12- This product is intended for indoor use only! To prevent risk of fire or shock, do not expose fixture to rain or moisture.
- 13- Make sure the distance between the fixture and the lighted object is not less than 0.5 meters. Make sure there are no combustible or explosive objects 0.5 meters around the fixture. Be sure that no ventilation slots are blocked.
- 14- Always disconnect from power source before servicing or replacing fuse and be sure to replace with same fuse source.
- 15- Secure fixture to fastening device using a safety chain.
- 16- Maximum ambient temperature (Ta) is 104° F (40° C). Do not operate fixture at temperatures higher than this.
- 17- In the event of a serious operating problem, stop using the unit immediately. Never try to repair the unit by yourself. Repairs carried out by unskilled people can lead to damage or malfunction. Please contact Technical Pro for the nearest authorized technical assistance center.
- 18- Never connect the device to a dimmer pack.
- 19- Make sure the power cord is never crimped or damaged.
- 20- Never disconnect the power cord by pulling or tugging on the cord.
- 21- Never carry the fixture directly from the cord. Always use the hanging/mounting bracket.
- 22- Avoid direct eye exposure to the light source while it is on.
- 23- Once installation and wiring is complete power on all your equipment with the volume and level controls turned DOWN. Once all the equipment is ON slowly raise the volume or level controls to their proper positions.
- 24- When grounding this unit, be sure to do so correctly, so as not to defeat the built-in grounding in this unit.
- 25- Before placing, installing, rigging, or suspending any product, inspect all hardware, suspension, cabinets, transducers, brackets and associated equipment for damage. Any missing, corroded, deformed, or non-load rated component could significantly reduce the strength of the installation, placement or array. Any such condition severely reduces the safety of the installation and should be immediately corrected. Use only hardware which is rated for the loading conditions of the installation and any possible short-term, unexpected overloading. Never exceed the rating of the hardware or equipment.
- 26- Consult a licensed, Professional Engineer regarding physical equipment installation. Ensure that all local, state and national regulations regarding the safety and operation of equipment are understood and adhered to.
- 27- Refer all servicing to qualified service personnel. Servicing is required when the apparatus has been damaged in any way, such as power supply cord or plug is damaged, liquid has been spilled or objects have fallen into the apparatus, the apparatus has been exposed to rain or moisture, does not operate normally, or has been dropped.

Introduction

Congratulations and thank you for your purchase of this Technical Pro LED stage effect light. To get the most from your unit it is recommended that you review all of the information provided in this instruction manual before operating this equipment.

LG500x Rear Panel

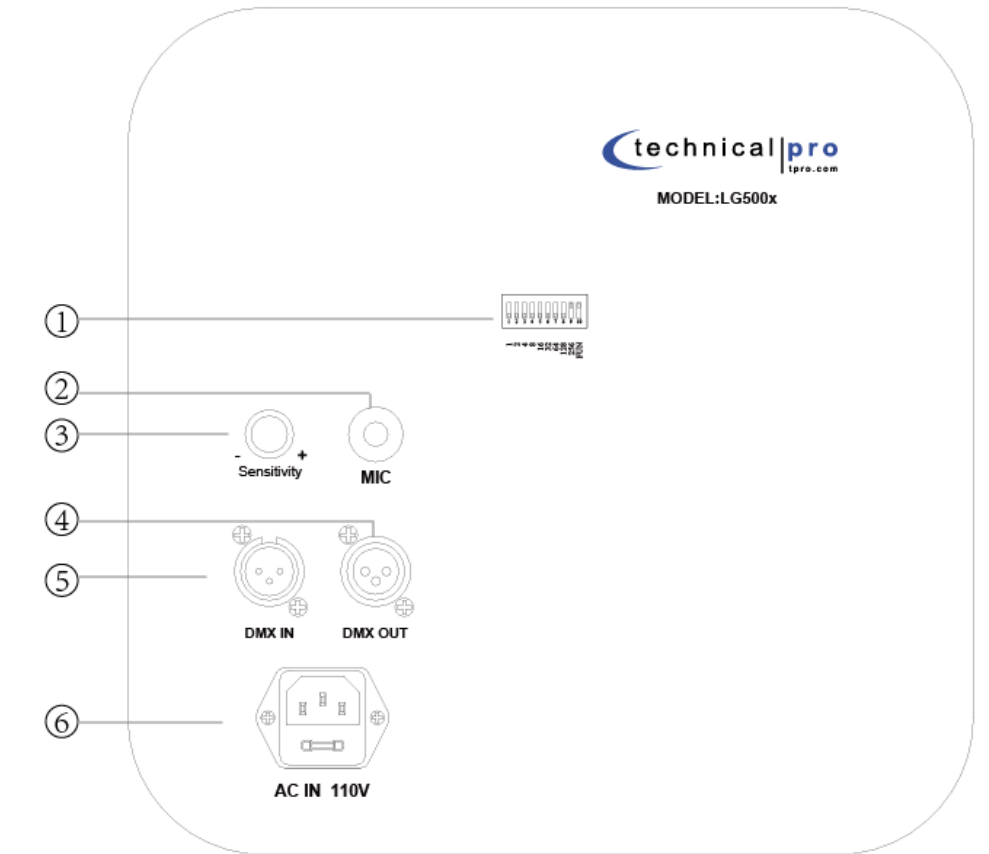

1. DIP Switches: The DIP switches can be used to set the fixtures to a certain setting / mode. When the fixture is connect to a DMX controller use the DIP switches to assign an address to the fixture.

2. Microphone: This built-in microphone will pickup any sounds when the unit is being operated in sound-activated mode. The fixture will illuminate changes according to the sound.

3. Sensitivity Knob: Use this knob to adjust the sensitivity of the lights when the fixture is operating in sound-activated mode.

4. DMX Output(XLR): DMX(Digital Multiplex) is the form of communication between controller and fixtures. When linking multiple LG500x units simply connect the DMX OUTPUT to the DMX INPUT on the next unit.

5. DMX Input (XLR):DMX(Digital Multiplex) is the form of communication between controller and fixtures. Connect the DMX output from the controller to this input, When linking multiple LG500x. More details on the settings can be found below.

6. Power Plug: Connect the plug to the AC Mains to power on the fixture.

AC Power:

This fixture runs on 110VAC, 50/60 Hz. Before powering on the unit, make sure the line voltage to which you are connecting it is within the range of accepted voltages.



Always connect the fixture to a switched circuit. Never connect the fixture to a rheostat (variable resistor) or dimmer circuit, even if the rheostat or dimmer channel is used only as a 0 to 100% switch.

To determine the power requirements for a particular fixture, see the label affixed to the back plate of the fixture or refer to the fixture's specifications chart. A fixture's listed current rating indicates its average current draw under normal conditions.



Always connect the fixture to a circuit with a suitable electrical ground.

The AC power cords supplied purposefully have 2 blades and one grounding prong. If your outlet is not equipped to handle this type of plug, do not attempt to forcefully plug this AC power cord into the outlet, and do not alter the plug so that it can fit in the outlet. The only course of action you can take is to find another outlet which is properly equipped to handle a grounded plug or have an electrician upgrade your electrical outlet. Be sure that the plug is well connected so that it does not disconnect in the middle of usage. If at any point in time the supplied AC power cord is punctured or damaged replace it with a new power cord from a local electrician.

What is DMX:

There are 512 channels in a DMX connection. Channels may be assigned in any manner. A fixture capable of receiving DMX will require one or a number of sequential channels. The user must assign a starting address on the fixture that indicates the first channel reserved in the controller. There are many different types of DMX controllable fixtures and they all may vary in the total number of channels required. Choosing a start address should be planned in advance. Channels should never overlap. If they do, this will result in erratic operation of the fixtures whose starting address is set incorrectly. You can however, control multiple fixtures of the same type using the same starting address as long as the intended result is that of unison movement or operation. In other words, the fixtures will be slaved together and all respond exactly the same.

DMX fixtures are designed to receive data through a serial Daisy Chain. A Daisy Chain connection is where the DATA OUT of one fixture connects to the DATA IN of the next fixture. The order in which the fixtures are connected is not important and has no effect on how a controller communicates to each fixture. Use an order that provides for the easiest and most direct cabling. Connect fixtures using shielded two conductor twisted pair cable with three pin XLR male to female connectors. The shield connection is pin 1, while pin 2 is Data Negative (S-) and pin 3 is Data positive (S+).

Maintaining the Fixture:

To maintain optimum performance and minimize wear, fixtures should be cleaned frequently. Usage and environment are contributing factors in determining frequency. As a general rule, fixtures should be cleaned at least twice a month. Dust build up reduces light output performance and can cause overheating. This can lead to reduced lamp life and increased mechanical wear. Be sure to power off fixture before conducting maintenance.

Unplug fixture from power. Use a vacuum or air compressor and a soft brush to remove dust collected on external vents. Clean all glass when the fixture is cold with a mild solution of glass cleaner or Isopropyl Alcohol and a soft lint free cotton cloth or lens tissue. Apply solution to the cloth or tissue and drag dirt and grime to the outside of the lens. Gently polish optical surfaces until they are free of haze and lint.

The cleaning of external optical lenses and/or mirrors must be carried out periodically to optimize light output. Cleaning frequency depends on the environment in which the fixture operates. Damp, smoky or particularly dirty surroundings can cause greater accumulation of dirt on the unit's optics. Clean with soft cloth using normal glass cleaning fluid. Clean the external optics at least every 20 days. Clean the fixture at least every 30/60 days. *Always dry the parts carefully after cleaning them. Never spin a fan using compressed air.*

DIP Instructions:

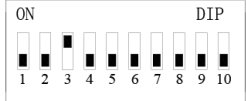
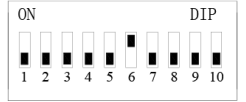
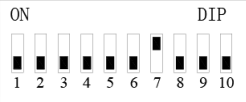
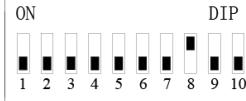
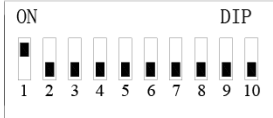
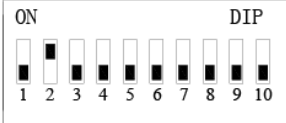
No.	DIP Description	Instruction
1	If "3" is on, it is LED strobe.	
2	If "6" are on, it is LED static color.	
3	If "7" is on, it is Sound-Activated mode.	
4	If "8" is on, it is Auto-pilot mode. (it will output all the built-in programs)	
5	If "1" are on, it is DMX mode, the CH1 of the lights will start from the first channel of the DMX.	
6	If "1, 2" is on, it is DMX mode, the CH1 of the lights will start from the second channel of the DMX.	

--

DIP Detail function

The Number under the DIP address: 1,2,4,8,16,32,64,128,256,512, it works with DMX Controller, when the DMX controller connect with the lights and many lights work together, you can set different lights with different channel of DMX Controller as the first channel of a special lights. In fact, this change the lights first channel position, And you can use one DMX controller to control many lights to show many different effects.

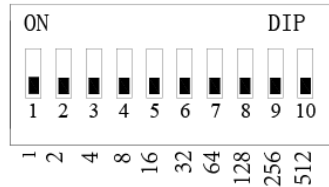

For example:

IF 1 on, it means to use the Channel 1 of the DMX controller to be the CH1 of the special lights. Then the Channel 2 in the DMX controller as the CH2 to control the lights, and so on...



IF 2 on, it means to use the Channel 2 of the DMX controller to be the CH1 of the special lights. Then the Channel 3 of the DMX controller as the CH2 to control the lights, and so on...



IF 3 on, it means to use the Channel 4 of the DMX controller to be the CH1 of the special lights. Then the Channel 5 of the DMX controller as the CH2 to control the lights, and so on...



IF 4 on, it means to use the Channel 8 of the DMX controller to be the CH1 of a special lights. Then the next channel 9 of the DMX controller as the CH2 to control the lights. And so on...

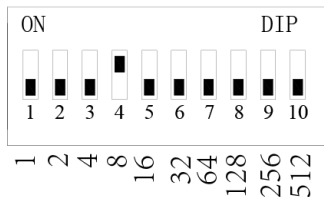

IF 5 on, it means to use the Channel 16 of the DMX controller to be the CH1 of a special lights. Then the next channel 17 of the DMX controller as the CH2 to control the lights, and so on...



IF 6 on, it means to use the Channel 32 of the DMX controller to be the CH1 of a special lights. Then the next channel 33 of the DMX controller as the CH2 to control the lights, and so on...



IF 7 on, it means to use the Channel 64 of the DMX controller to be the CH1 of a special lights. Then the next channel 65 of the DMX controller as the CH2 to control the lights, and so on...



IF 8 on, it means to use the Channel 128 of the DMX controller to be the CH1 of a special lights. Then the next channel 129 of the DMX controller as the CH2 to control the lights, and so on...



IF 9 on, it means to use the Channel 256 of the DMX controller to be the CH1 of a special lights. Then the next channel 257 of the DMX controller as the CH2 to control the lights, and so on...



IF 1 and 3 on, it is $1+4=5$, it means to use the Channel 5 of the DMX controller to be the CH1 of a special lights, then the next channel 6 of the DMX controller as the CH2 to control the lights, and so on.



IF 4 and 5 on, it is $8+16=24$, it means to use the Channel 24 of the DMX controller to be the CH1 of a special lights, then the next channel 25 of the DMX controller as the CH2 to control the lights, and so on.



(Note: some of the DMX controller provide less than 512 channels, some DMX controller provide more than 1240 channels. This depends on different DMX controller.)

9 Channel Mode (DMX):

When use the LG500x together with a DMX controller, set the DIP to 10 on, then use the DMX controller to adjust the settings of CH1, CH2, CH3 and CH4, CH5, CH6, CH7, CH8 to show different effect.

DMX512 Function:

Channel	Value	Function
CH1	0-199	Speed(Connect with CH2,3,4,5,6,7,8≥32)
	200-249	Auto-pilot
	255	Sound-Activated
CH2,3,4,5,6,7,8 (each channel control one separate LED area, total 7 LED areas.)	0-31	NULL
	32-127	Strobe
	128-134	NULL
	135-255	RGB output in turns
Channel 9 (this channel control all the LED)	0-31	NULL
	32-127	Strobe
	128-134	NULL
	135-255	RGB output in turns

Technical Parameters:

LED Light	Red/Green/Blue
LED source:	469pcs (red:280, Green:63 , Blue:126)
System Port	DMX512 input and output port
Control Mode	Auto,Sound Active,DMX512
Demo Effect	255 grade high brightness level,0-100% linear dimming.
Power Supply	AC110V
Power	15W
Product dimension	11.4"X13"X11"
DMX channel	9CH