

ASSEMBLY, MAINTENANCE, & **USER MANUAL**

MODEL #SWG1110

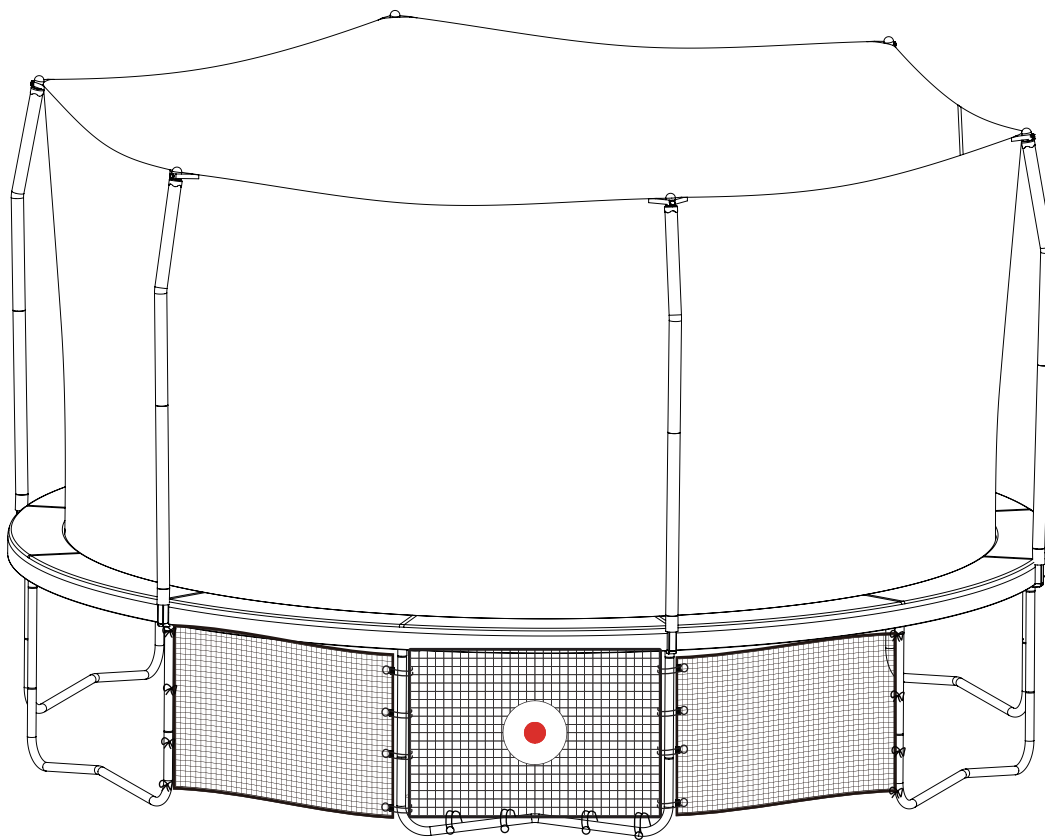

WARNING

Read all precautions and instructions in this manual before using this equipment. Save this manual for future reference.

SKYWALKER

TRAMPOLINES

Skywalker Holdings LLC
P.O. Box 574, Brigham City, UT 84302

TABLE OF CONTENTS

Part List.....	2
Part Identification.....	3
Assembly.....	4-10
Limited Warranty.....	11



STOP EVERYTHING YOU'RE DOING AND REGISTER YOUR PRODUCT

Find our warranty registration online by typing in: www.skywalkertrampolines.com/registration/

You'll need to have the following information handy:

- Name
- Address
- Phone number
- Date of purchase
- Email address
- Model number
- Serial number
- Retailer where product was purchased



SKYWALKER MODELS COMPATIBLE WITH THIS PRODUCT:

- All Skywalker Trampolines 10' round models
- All Skywalker Trampolines 12' round models
- All Skywalker Trampolines 13' round models
- All Skywalker Trampolines 14' round models

HEY WE'VE GOT SOMETHING REALLY IMPORTANT TO SAY

Skywalker Trampolines belongs to a family of brands focused on providing active products. Check us out online! We've got **assembly videos** (for those of you who prefer movies over books), **FAQs** (so you know you're not the only one who needs help), **additional products** (including trampolines, sports, fitness, and playground equipment), and most importantly, find us on social media! Because we want to be your friend. **We'd love to see how you are using our products!**



@skywalkertrampolines



skywalkertrampolines



@skywalker_trampolines



@swtrampolines



@swtrampolines



@skywalkertrampolines



www.skywalkertrampolines.com



IMPORTANT

Trampoline/enclosures and game attachments are susceptible to winds.



WARNING

CHOKING HAZARD- Small parts not for children under 3 years.



WARNING

Adult assembly required.

PART LIST

Key No.	Qty.	Description
1	1	Kick Back Net
2	2	Side Net
3	16	Elastic with Ball

PART IDENTIFICATION

Before you begin, take a look at the drawings below to make sure you have all the parts! The numbers in the squares to the left (key numbers) will help you identify the parts during assembly.

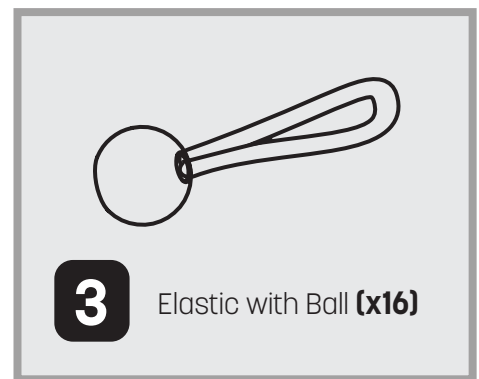
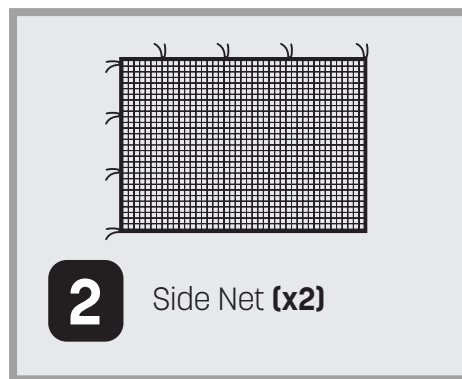
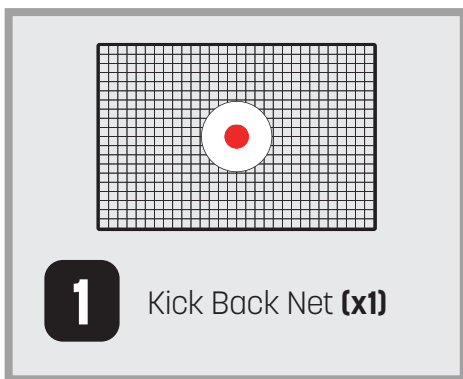

ORDERING REPLACEMENT PARTS

We get it, sometimes things happen. But the fun shouldn't stop just because you need a new bolt or screw! To order replacement parts, check out our website at: www.skywalkertrampolines.com or call our toll-free Customer Care Hotline at 1-866-603-Jump (5867), Monday - Thursday, 8 a.m. until 5 p.m. and Friday, 8 a.m. until 3 p.m. Mountain Time (excluding holidays).

Our customer service team will ask you a few questions in order to get the replacement part sent out as soon as possible. We're not trying to complicate your life, we promise.

When calling, make sure to have the following information ready:

- The model # of the product (see the front cover of this manual)
- The key # and description of the part (see the part list on the next page)
- The quantity needed (only you know the answer to that one!)

BEFORE YOU BEGIN

Thanks for choosing Skywalker Trampolines! We're just as excited as you are to help your family live an active (but most importantly **FUN**) lifestyle. This model is one of our favorites, and we're confident you'll love it too. To make things easier for you, we've listed important information that you (and your little outdoor adventurers) need to know. Make sure you brush up on the warnings, instructions, assembly, maintenance, and use of your new product because there will be a pop quiz at the end! (Okay, not **REALLY**, but if you're still reading this, props to you! You're awesome).

ASSEMBLY

STEP 1

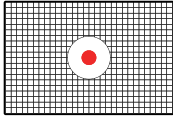

1 Kick Back Net (x1)

The kick back net accessory fits round trampoline sizes 10'-14'. Use the picture below to locate the correct holes to attach the kick back net to your trampoline.

The key at the bottom will tell you which holes to use. The numbers along the sides are there to help you count and find the exact hole that you need.

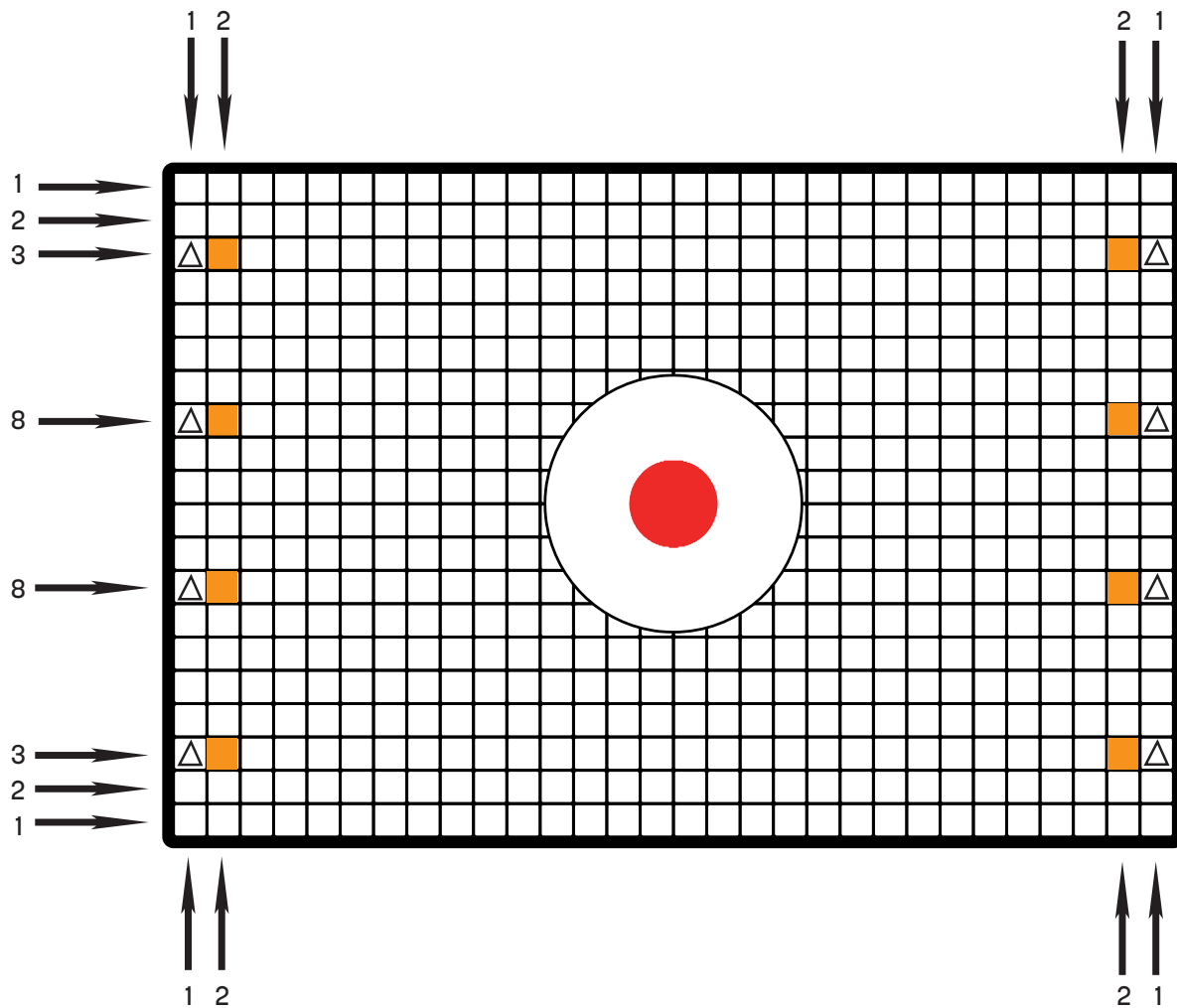

 12' round & 13' round trampoline holes

 10' round & 14' round trampoline holes



STEP 2

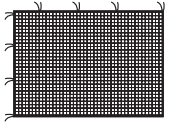

2 Side Net (x2)



3 Elastic with Ball (x8)

The bullsye part of the net needs to be **centered on a leg piece** (not between two legs).

Starting at one side of the kickback, thread the elastics through the holes on both the kick back net and a side net **(2)** then wrap the elastics around the trampoline leg and secure.

Make sure to use the key from step one for correct hole and elastic placement.

Then simply repeat with the second side net on the other side.

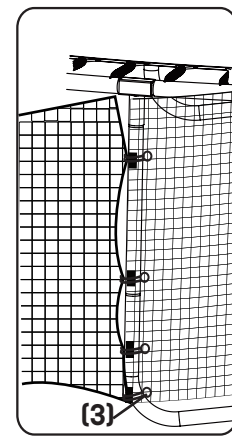
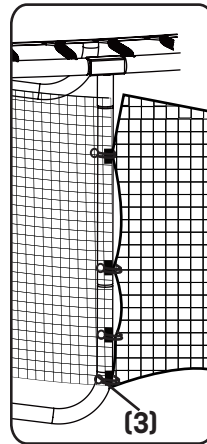
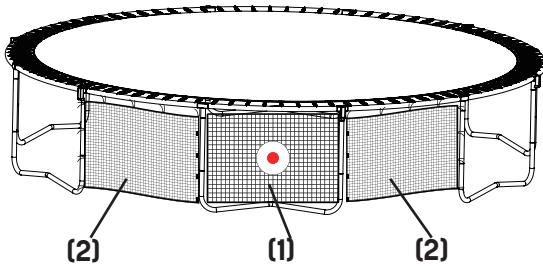

STEP 3

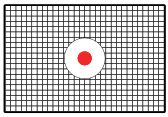

1 Kick Back Net (x1)

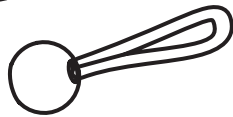

3 Elastic with Ball (x8)

Now attach the bottom and top of the kick back net **(1)** to the lower leg and upper frame of the trampoline by using the elastics with ball **(3)**.

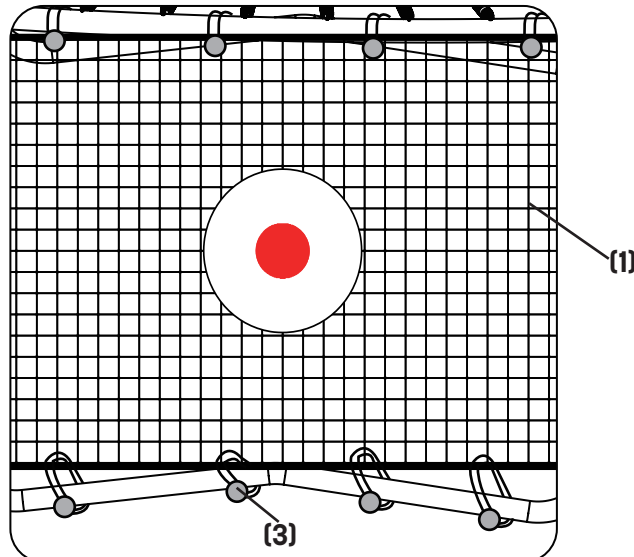

ASSEMBLY

STEP 4

Now, tie the side nets to the legs of your trampoline with the attached straps. If you have a 10' round and 14' round trampoline, the net should just reach the legs. If you have a 12' or 13' round trampoline, you may need to wrap the net around the leg before tying to make it nice and tight.

10' round & 14' round trampoline

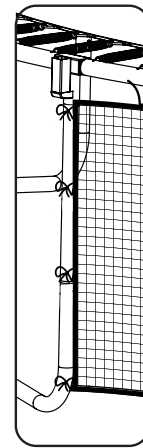
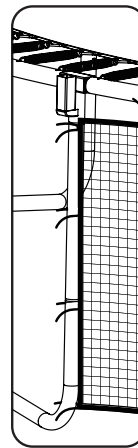
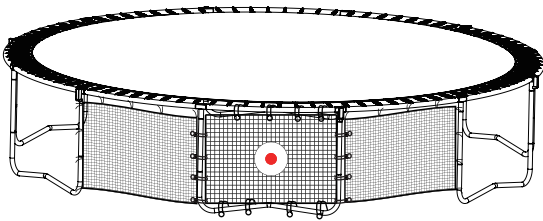

12' round & 13' round trampoline

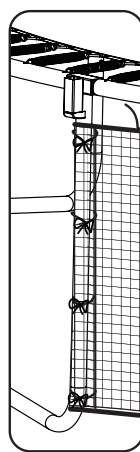
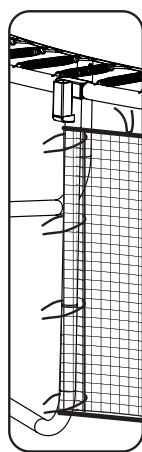
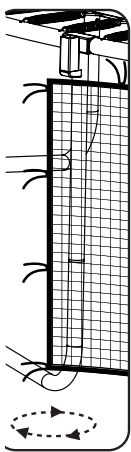

STEP 5

Now tie the tops of the nets to the frame of your trampoline with the attached straps.

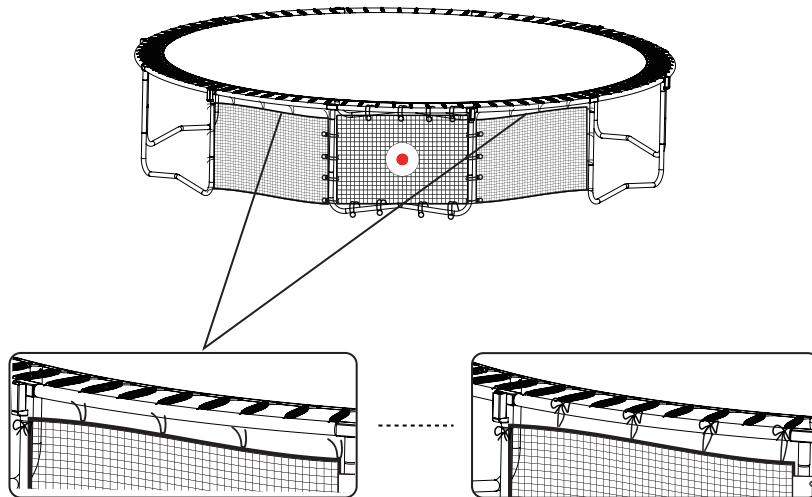

STEP 6

Congratulations on setting up your new kick back net! So here comes the real question, **are you satisfied with this product?** If you are, go ahead and **write a review** on the retailer's site you bought it from. We'd really appreciate it, and if we could, we'd give you a gold star. Have questions? Contact us directly! We're happy to help. See contact info on page 2-3.

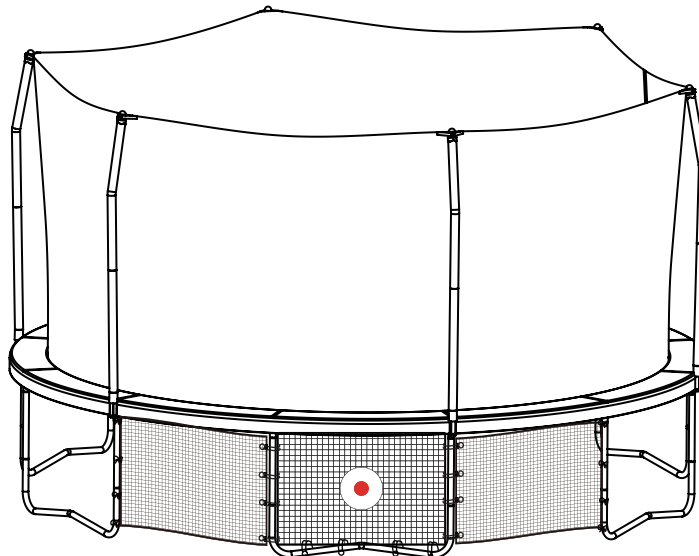

LIMITED WARRANTY

Skywalker Holdings, LLC warrants its products to be free from defects in material and workmanship under normal use and service conditions. **The steel frame is warranted for three (3) years after the date of purchase. All other parts are warranted for one (1) year after the date of purchase.** Warranty coverage extends only to the original retail purchaser from the date of original purchase. This warranty is only valid concerning products used for residential use. Products used for commercial use, such as schools and daycares, will not be covered.

WHAT IS NOT COVERED?



Weather Damage: The warranty does not cover damage due to the effects or acts of nature, such as earthquakes, wind, hurricanes, tornadoes, lightning, rain, fire, snow, excessive heat and cold conditions and/or sun damage. During the winter months the soft materials will need to be removed and stored in a dry place out of the snow. If left unprotected in the winter months, some components may become damaged, voiding this warranty.



Fading and Rust: Skywalker does not warranty against rust or corrosion. Some areas may have higher air salt content, higher humidity, heavier rain and heavier snow. Skywalker does not warranty against fading. We suggest customers use a UV protectant to extend the life of the product.



Loss or Damage: Loss or damage caused by shipping, abuse, misuse, improper/abnormal usage or unauthorized repairs are not covered by this warranty and may also void the warranty.



Unauthorized Replacement Parts: The warranty will become void if any defects or damages are associated with the use of unauthorized replacement parts. All replacement parts must be obtained from an authorized agent.



Assembly Service: The warranty does not cover acts or omissions provided by a third-party assembly service. It is the customer's responsibility to check all boxes and confirm all components are included and in their proper condition before installation occurs.

INSPECTION AND REPLACEMENT PARTS:

1. Your product should be inspected upon unpacking and set up and thereafter on a regular basis. Worn, damaged or broken parts should be replaced immediately and before use.
2. Call the Skywalker Trampoline Customer Service Department at 1-866-603-5867 to file a warranty claim. Be prepared to provide the following information: name, shipping address, a copy of your original sales receipt, a brief description of the problem and cause, model number and serial number. We may also ask for photos of the damaged/defective parts.
3. Customer service will review your claim and contact you with further instruction.

NOTE: All requested information must be provided in order to review your warranty claim.

To order replacement parts for your product please visit www.skywalkertrampolines.com

Skywalker Holdings, LLC, PO Box 574, Brigham City, UT 84302 USA.

Printed in China © 2023 Skywalker Holdings, LLC

NOTE: Skywalker Holdings, LLC is not responsible or liable for indirect, special or consequential damages arising out of or in connection with the use or performance of the product or other damages with respect to any economical loss, loss of property, loss of revenue or profits, loss of enjoyment or use, cost of removal, installation or other consequential damages. Some states do not allow the exclusion or limitation of incidental or consequential damages. Accordingly, the above limitation may not apply to you.

The warranty extended hereunder is in lieu of all other warranties and any implied warranty of merchantability or fitness for a particular purpose is limited in its scope and duration to the terms set forth herein. Some states or countries do not allow limitations and how long an implied warranty lasts. Accordingly, the above limitations may not apply to you. This warranty gives you specific legal rights. You may also have other rights which vary state to state or country to country. This warranty is valid only in the country the product was purchased.

This warranty is valid only in the country the product was purchased.