



Goliath

Sauna heater for commercial saunas. Floor-standing model.

Premium class sauna heater for the Finnisch (dry) sauna. Designed for very intensive, demanding commercial use in large sauna cabins. Optimized construction with extra-large rock store for 75 kg rocks and strong air convection. Heating elements have no contact to sauna stones to facilitate servicing and extend lifetime of heating elements.

Your advantages:

- High performance heater for heavy-duty commercial use.
- For design oriented, demanding facilities.
- Reinforced construction, all made of stainless steel.
- Extra-large rock store for approx. 75 kg volume.
- Friendly for servicing and maintenance, heating elements can be replaced without removing the rocks.
- Made in Germany quality from EOS.

Specifications:

Outer shell:	Stainless steel, scratch-resistand anthracite pearl effect powder coating.
Top:	Brushed stainless steel
Rear wall:	Stainless steel, blank polished
Rock store:	Stainless steel, above heating elements
Terminal box:	Stainless steel, at the rear side, with ceramic terminals
Power range:	18, 24, 30 and 36 kW
Power supply:	400 V 3N AC 50 Hz
Rock store:	approx. 75 kg, incl. in delivery
Dimensions (HxWxD):	83 x 96 x 47 cm
Installation:	Floor-standing model



Optional brackets allow to mount a custom-made heater guard rail directly to the heater. This provides a reasonable protection against accidental touching the heater and at the same time keeps it fully visible and aesthetically looking.

Notice: wooden parts are not included.
Item no. 94.5067, for 3-sided guard rail, anthracite finish.



Connection diagram

18 - 24 kW

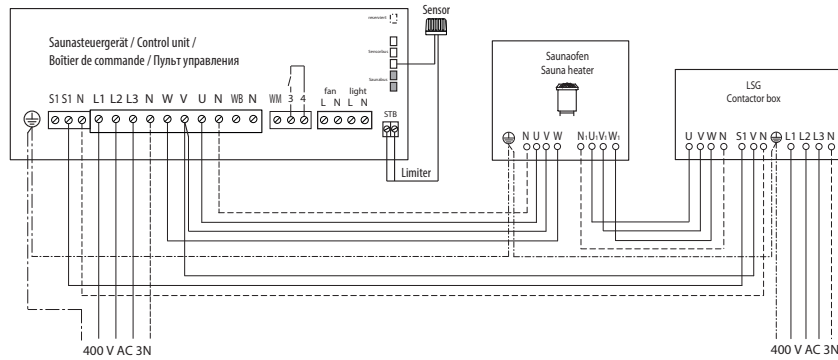

30 - 36 kW

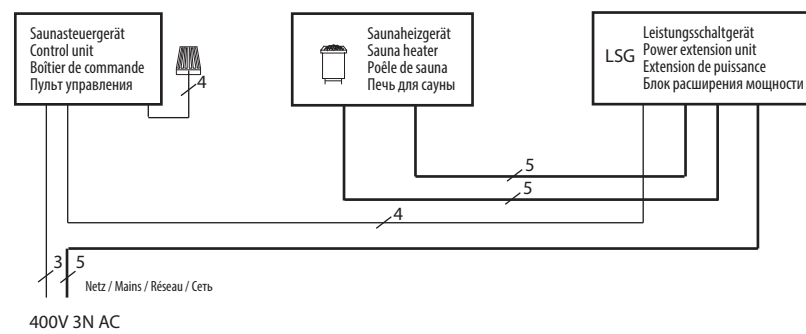

Minimum clearances

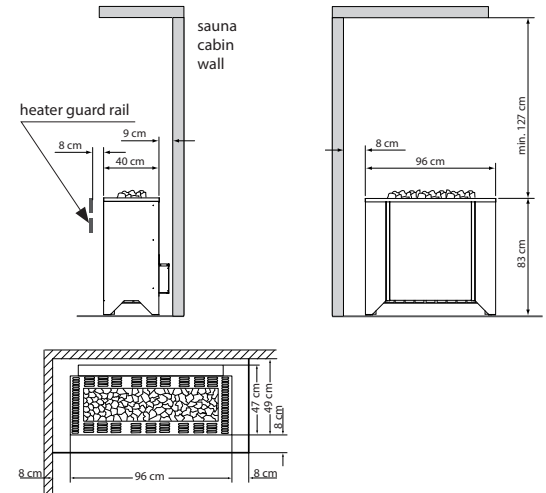

Suitable control units

Model	Item no.
Econ D2	94.5204
Econ D3	94.5549
Econ D4	94.5842
Emotec D	94.5559
Emotouch II+	94.5561
EmoTouch 3	94.6505

Power extension unit (e.g. Emotec L09R, LSG18, LSG36) is required.

Technical specifications

Power output	Electrical connection	Connection mains - control unit	Connection control unit - heater	Connection mains - LSG	Connection LSG - heater	Connection control unit - LSG unit
18 kW	3N AC 50 Hz 400 V	5 x 2,5 mm ²	5 x 1,5 mm ²	5 x 2,5 mm ²	5 x 1,5 mm ²	4 x 1,5 mm ²
24 kW			5 x 6 mm ²	5 x 4 mm ²		
30 kW		3 x 1,5 mm ²	--	5 x 16 mm ²	2 St. 5 x 4 mm ²	
36 kW			2 St. 5 x 6 mm ²			

All cross sections of connection cables are minimum diameters in mm² (copper wire).

Spare heating elements

Description	Item no.
18 kW - 18 x 1000 W	2001.1599
24 kW - 18 x 1333 W	2001.1598
30 kW - 18 x 1666 W	2001.3763
36 kW - 18 x 2000 W	2001.3931
Mounting brackets for guard rail	94.5067

Item no.	Power output	Electrical connection	Fuse protection control unit	Fuse protection LSG unit	Dimensions H/W/D, in cm	For sauna cabin size	Min. size of air inlet and outlet	Weight without rocks	Stone filling	Power extension required
90.4805	18 kW	3N AC 50 Hz 400 V	3 x 16 A	3 x 16 A	83 x 96 x 47	24 - 35 m ³	50 x 6 cm	~85 kg	~75 kg	L09R
90.4806	24 kW			3 x 35 A		35 - 45 m ³	50 x 8 cm			LSG 18
90.4807	30 kW		3 x 16 A	3 x 63 A		45 - 65 m ³	50 x 10 cm			LSG 36
90.4808	36 kW					65 - 75 m ³	50 x 10 cm			