

# UTV Rear Cargo Bag Mounting Instructions

Please read instructions carefully before installation. We recommend this product be installed by a qualified, and experienced technician. If you are unsure of any of the below directions and or your ability to correctly and securely install this product, please contact us or your local dealer for help. Below diagrams show typical installation, your vehicle may be different so please use diagrams as a guide. Make sure your vehicle is clean and free from dirt, road grime etc. where the this product mounts. It is the riders responsibility to make sure the product is mounted and secure before each use. Loading the bag may result in a change of position, always check for proper mounting position after loading and before each and every ride.

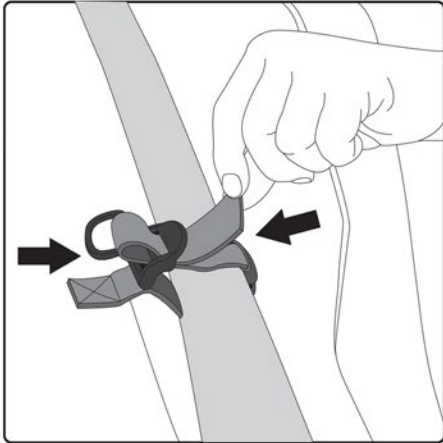

Place the cargo bag in bed of RZR or UTV with door flaps facing the rear of vehicle. Attach the 2 top straps to the cross bar, wrap webbing around the tubing and threading thru the buckle and pull tight.

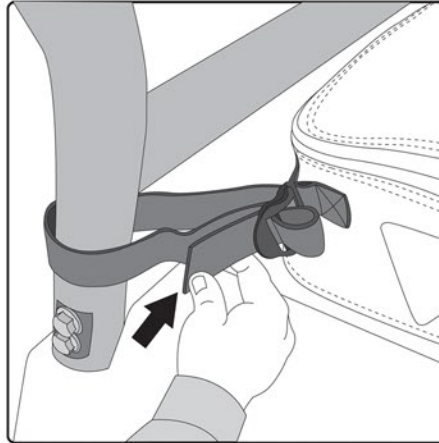

On the end of each side, wrap the 2 straps around the upright roll cage bar and thread back thru the buckle and pull tight.

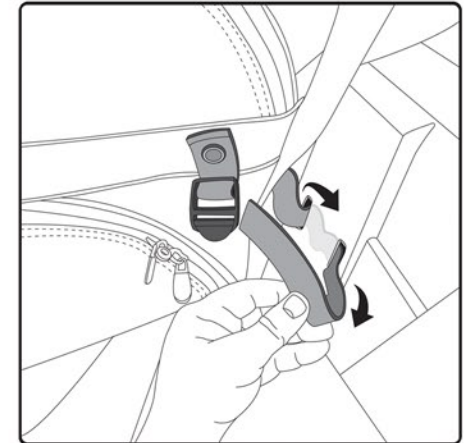

Using one of the lower straps on the side of the bag, attach to secure location or for RZR, pass strap thru the side slot closest to the front of vehicle and loop back thru the next slot and pull excess strap through. Accessing this from the side of the vehicle make this easier.

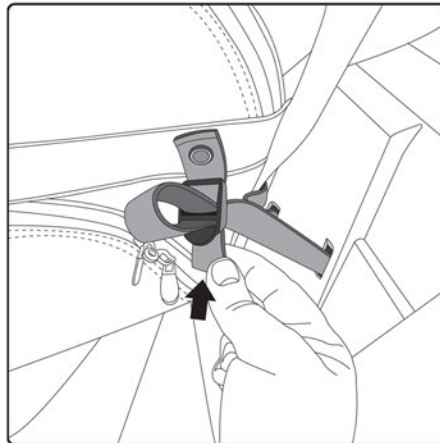

Once through, thread the strap thru the buckle and pull tight. Repeat on other side of bag.

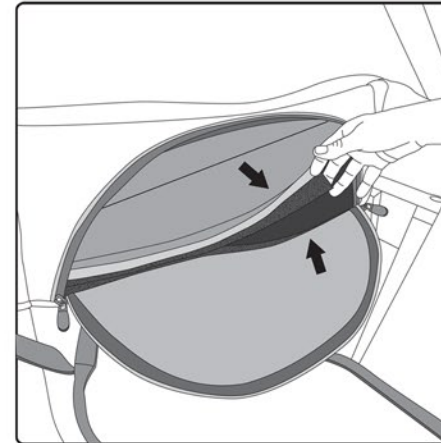

There is a collapsible shelf between the upper and lower compartments that can be detached from the self fastening webbing to make one large main compartment. always place heavier object at bottom of bag.

## Warning:

Read the installation instructions and make yourself familiar with the process of installing the Nelson-Rigg® product(s) on your bike. It is your responsibility to mount the product correctly and securely as outlined in these instructions. Nelson-Rigg® products are intended for use at USA street legal speeds as posted by the individual States. Nelson-Rigg® luggage must not be overloaded. Max carrying capacity is 10 lbs per bag or the maximum load suggested by the manufacturer of the vehicle, whichever is less.

Failure to adhere to these warnings may result in, but not be limited to: the luggage becoming detached, the product becoming tangled in moving parts of the vehicle, unstable vehicle dynamics, reduction in the ability to control the vehicle. The result(s) of could lead to serious injury.

**Always ride safely, adhering to the local highway regulations. Always wear a helmet and protective apparel.**

3518-A Lake Center Dr Santa Ana, CA 92704  
Tel (714)850-1811 Fax (714)850-1848  
e-mail: [info@nelsonrigg.com](mailto:info@nelsonrigg.com) [www.nelsonrigg.com](http://www.nelsonrigg.com)

