

ASSEMBLY INSTRUCTIONS

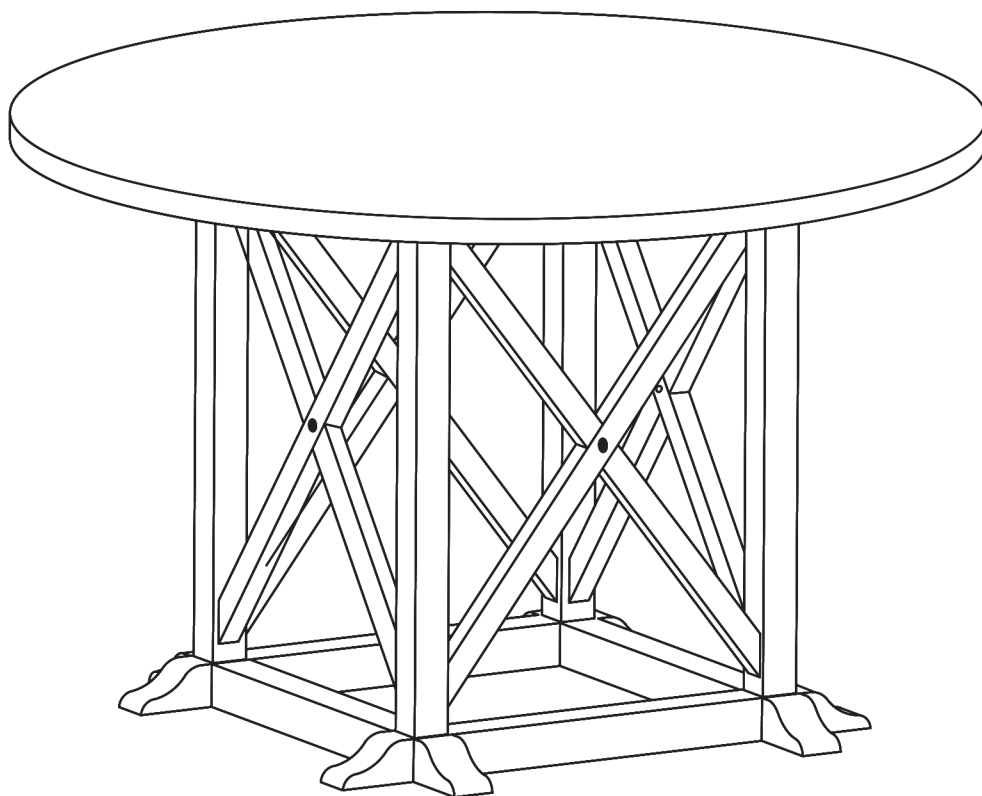

TOOLS REQUIRED

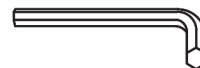

Allen Wrench

(Included)



**2 - People
Recommended**

ASSEMBLY RATING



EASY —————> DIFFICULT

The Assembly Rating is a 5-point system showing the level of effort needed to assemble a specific product.



CHECK BEFORE STARTING

Are you missing anything?

Double-check all parts, hardware and accessories listed are all accounted for.

Should we send any replacements?

Are there any irregularities or flaws in the parts? We can send replacements!

Check out our Quick Tips!

We recommend reviewing the pre-assembly handouts. Even experts need a refresher now and then!

Prep Time!

Please review the assembly instructions and all diagrams prior to assembling.

PRE ASSEMBLY INTRODUCTION

We understand building ready-to-assemble furniture can be a challenging experience for some. To help avoid confusion, we have provided some helpful tips that may speed up the process.

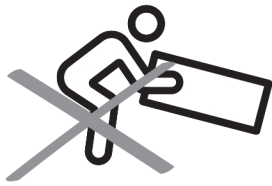

Teamwork

ALWAYS have at least two people to help with transporting and assembling the product to avoid potential injury and/or damage.

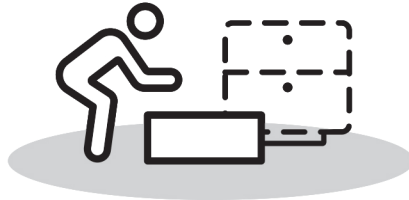
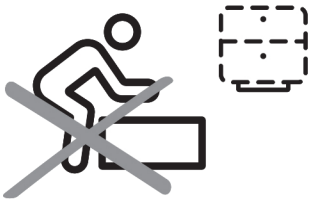

Suitable Location

Assembling near the area of the intended location is highly recommended.



Sufficient Space

Make sure you have enough space to move around during the assembly.



Avoid Scratches

Use cardboard, blankets or a carpeted area while assembling furniture to prevent to prevent scratches and damages.

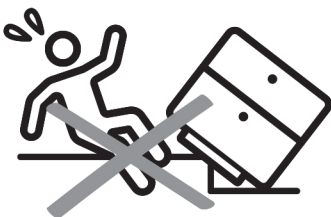

Flat Surface

Make sure the furniture rests on a flat and level surface with each leg evenly touching the floor.

ASSEMBLY AND CARE ADVICE



FAILURE TO FOLLOW THE GUIDELINES BELOW MAY RESULT IN INJURY AND/OR PROPERTY DAMAGE.



Position each part correctly and insert screws or bolts into their respective holes.

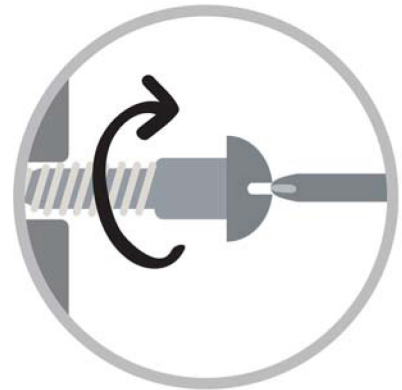

Turn clockwise to tighten and only tighten when step is completed or when instructed to do so.



Use the appropriate hand tools or power tools for assembly. Select steps, such as tightening screws and/or bolts, may require hand tools to avoid causing damage during assembly.



Save the instructions and store any supplied tools for later maintenance.

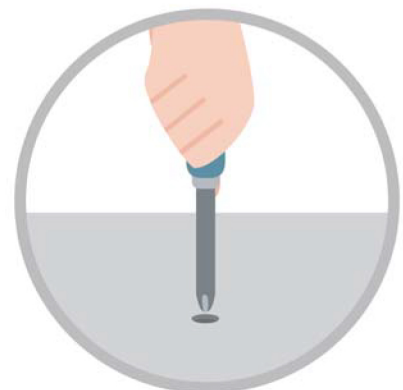

After two weeks, check and tighten any loose hardware and repeat again every six months thereafter.

IT IS THE USER'S RESPONSIBILITY TO MAINTAIN THE FURNITURE. THE HARDWARE MAY LOOSEN OVER TIME AND MAY CAUSE THE FURNITURE TO BE WOBBLY AND UNABLE TO SUPPORT ITS INTENDED WEIGHT CAPACITY. THIS MAY LEAD TO COLLAPSE AND MAY CAUSE SERIOUS INJURY.

ROUND DINING TABLE



- Please keep instructions for future reference.
- Check the quantity and irregularity of parts and hardware before you start.

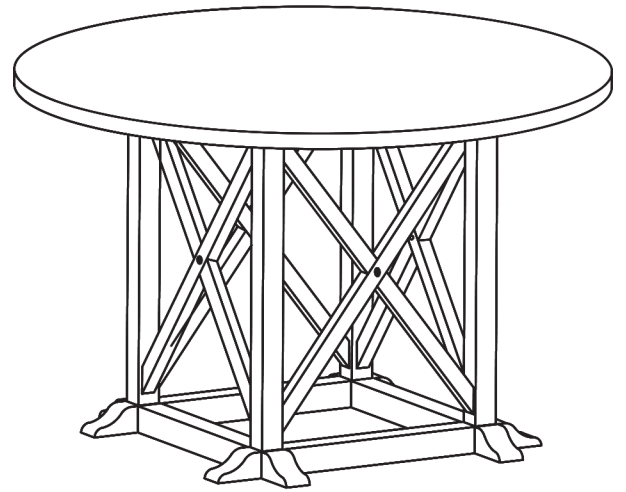

PARTS

#1 1pc



Table Top

#2 4pcs

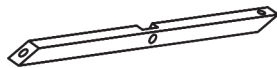

Outward Stretcher

#3 4pcs

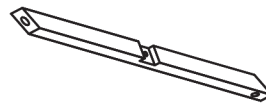

Inward Stretcher
with embedded Nut

#4 4pcs



Table Leg

#5 2pcs

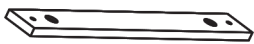

Mounting Plate

#6 2pcs

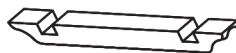

Upper Leg Base

#7 2pcs

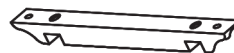

Lower Leg Base

HARDWARE

#A 4pcs



M6 x 25MM
Bolt

#B 24pcs



M6 x 35MM
Bolt

#C 4pcs



M6 x 70MM
Bolt

#D 32pcs



M6 x 13MM
Spring Washer

#E 16pcs



M6 x 14MM
Flat Washer

#F 16pcs



M6 x 19MM
Flat Washer

#G 4pcs











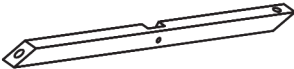

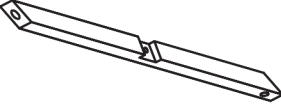

M6 Adjuster
Base Leg

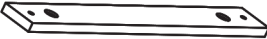
#H 1pc

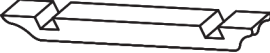

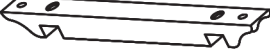
M4 Allen Wrench

Carton	Designation		Part	Hardware
	Table Top	# 1		
	Outward Stretcher	# 2		 #A x 4pcs
	Inward Stretcher	# 3		 #B x 24pcs  #C x 4pcs
	Table Leg	# 4		 #D x 32pcs
	Mounting Plate	# 5		 #E x 16pcs  #F x 16pcs
	Upper Leg Base	# 6		 #G x 4pcs
	Lower Leg Base	# 7		 #H x 1pc

ASSEMBLY INSTRUCTIONS

1

- Part #2 x2pc
- Part #3 x2pc
- Part #4 x4pcs
- Hardware #A x2 pcs
- Hardware #B x8 pcs
- Hardware #D x10 pcs
- Hardware #E x8 pcs
- Hardware #F x2 pcs
- Hardware #H x1 pc

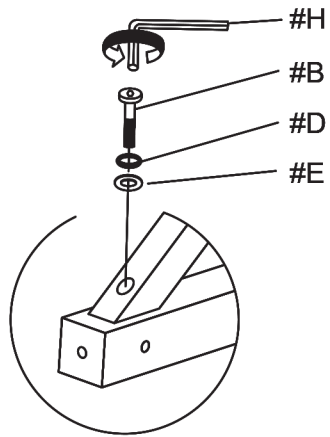

Combine outward Stretcher (#2) together with Inward Stretcher (#3), then secure by using bolts (#A) then with washers (#D,F). Next align the Table Leg (#4) to the assembly stretcher secure by using bolts (#B) then with washers (#D,E).

X2

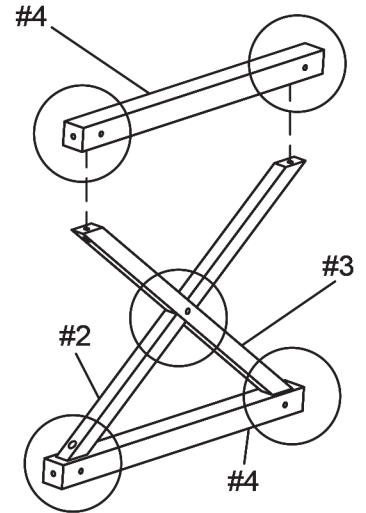
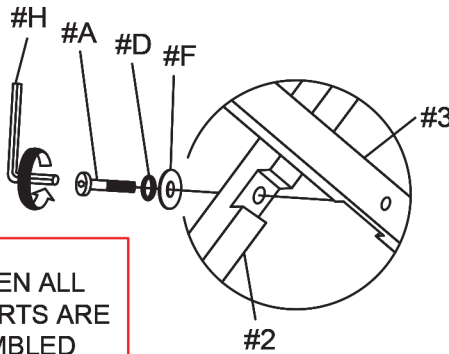

⚠ DO NOT TIGHTEN ALL BOLTS UNTIL ALL PARTS ARE COMPLETELY ASSEMBLED

2

- Part #2 x2pcs
- Part #3 x2pcs
- Hardware #A x2pcs
- Hardware #B x8pcs
- Hardware #D x10pcs
- Hardware #E x8pcs
- Hardware #F x2pcs
- Hardware #H x1pc

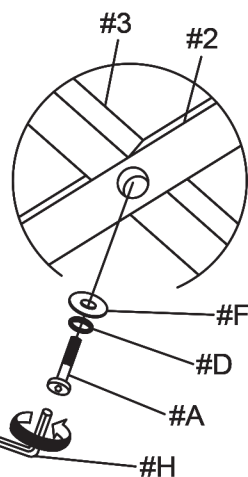

Combine outward Stretcher (#2) together with Inward Stretcher (#3), then secure by using bolts (#A) then with washers (#D,F). Next use assembly stretcher to the assembly table leg then secure by using bolts (#B) then with washers (#D,E)

⚠ DO NOT TIGHTEN ALL BOLTS UNTIL ALL PARTS ARE COMPLETELY ASSEMBLED

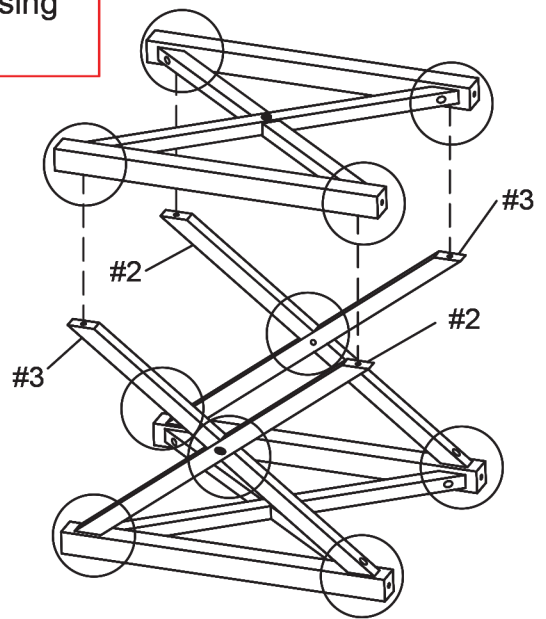
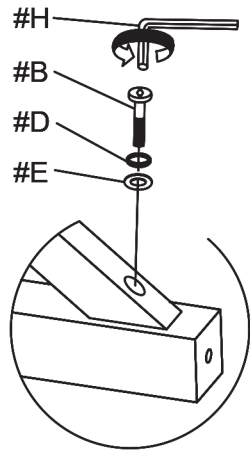

ASSEMBLY INSTRUCTIONS

3

- Part #5 x2pcs
- Hardware #B x4pcs
- Hardware #D x4pcs
- Hardware #F x4pcs
- Hardware #H x1pc

Align the Mounting Plat (#5) to the Table leg (#4) secure by using bolts (#B) then with washers (#D,F).

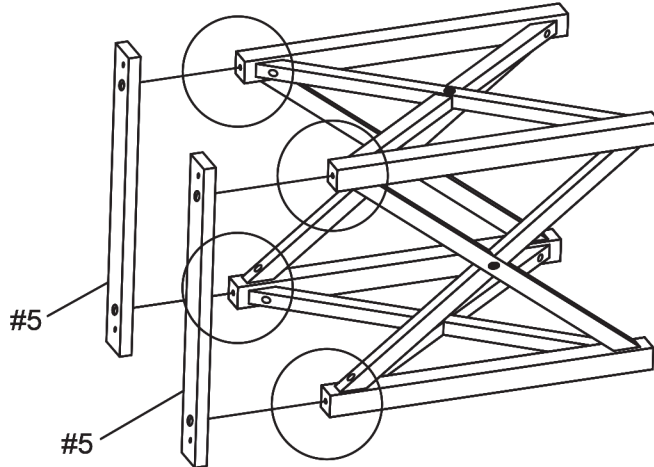
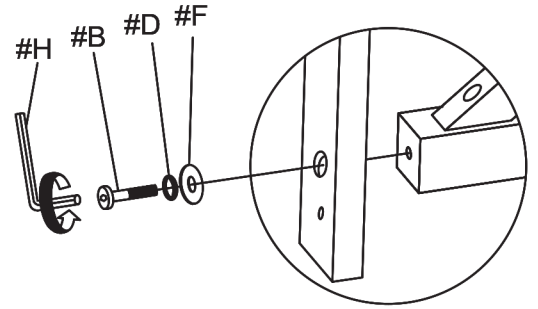

4

- Part #6 x2pcs
- Part #7 x2pcs
- Hardware #C x4pcs
- Hardware #D x4pcs
- Hardware #F x4pcs
- Hardware #H x1pc

Align the Lower Leg Base (#7) to the Upper Leg Base (#6), then secure by using bolts (#C) then with washers (#D,F) in the Leg.

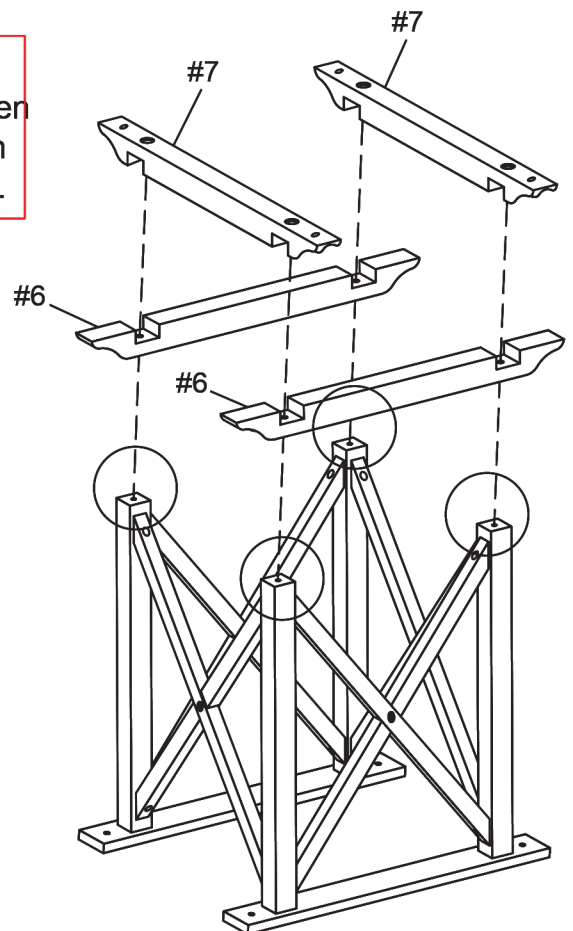

⚠ DO NOT TIGHTEN ALL BOLTS UNTIL ALL PARTS ARE COMPLETELY ASSEMBLED

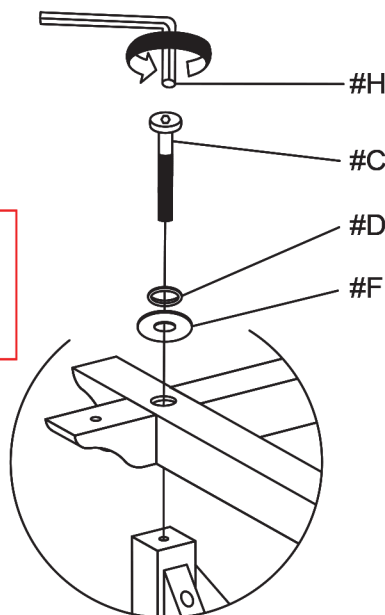

ASSEMBLY INSTRUCTIONS

5

Align base to top (#1), then secure by using bolts (#B) with washers (#D,F).

- Part #1 x1pc
- Hardware #B x4pcs
- Hardware #D x4pcs
- Hardware #F x4pcs
- Hardware #G x4pcs
- Hardware #H x1pc

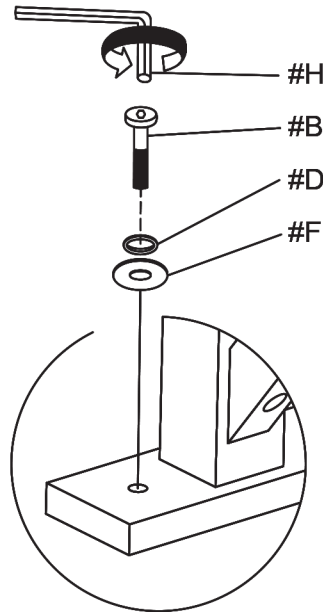

Attach levelers (#G) to the base.

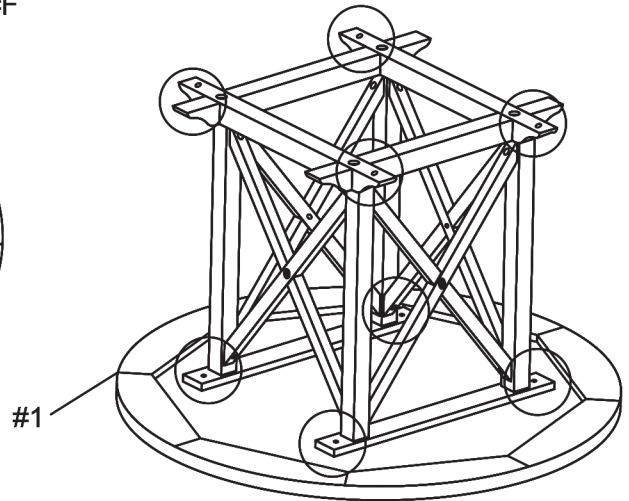
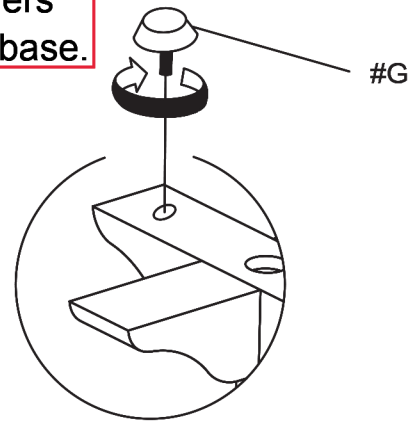

6

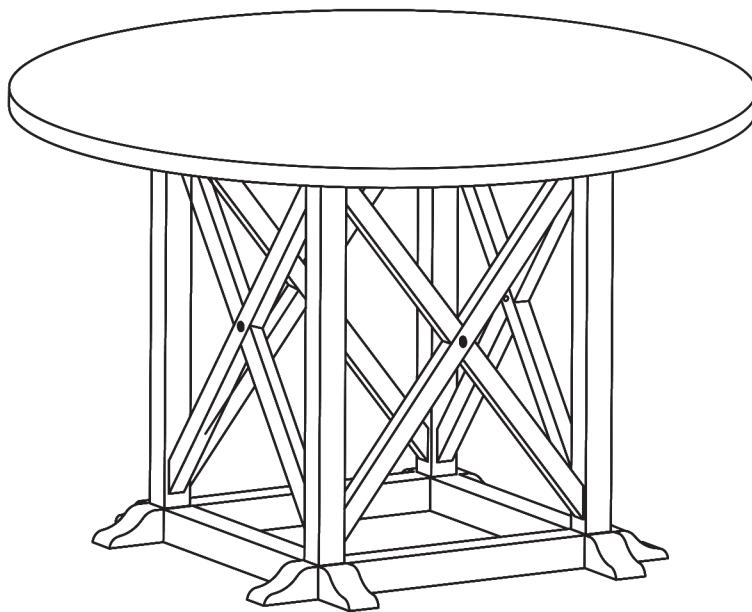

ASSEMBLY COMPLETED



Please ensure the furniture rests on an even and flat surface. If the product wobbles or feels loose, double-check all bolts and/or screws are properly tightened and secured.



Keep this handy!

Please retain this instruction manual and any order-related information for future reference.



Lift, don't drag!

To avoid damage to product please always LIFT the product when transporting or adjusting the placement.