

MODEL: PANDA BED (Q)

ASSEMBLY INSTRUCTIONS

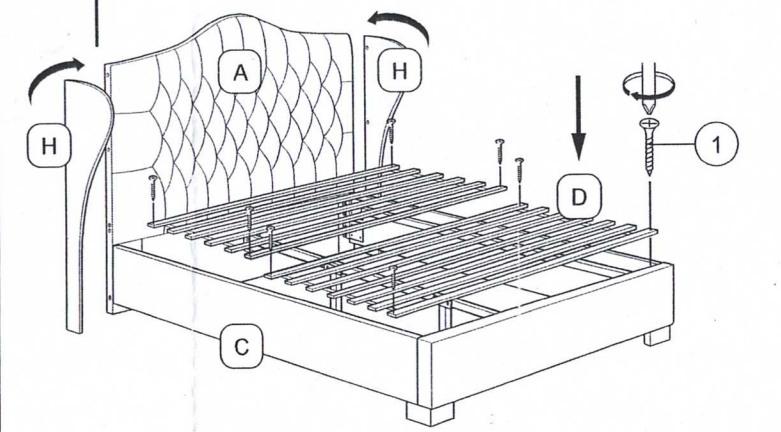
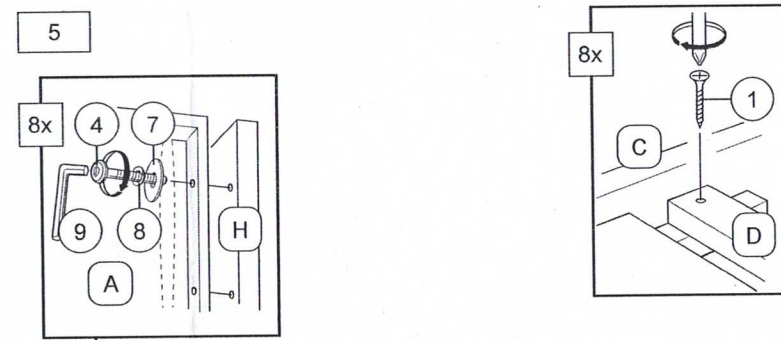
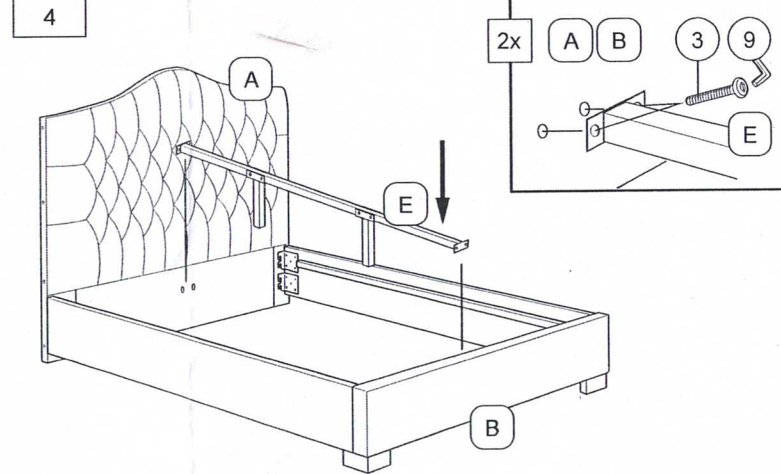
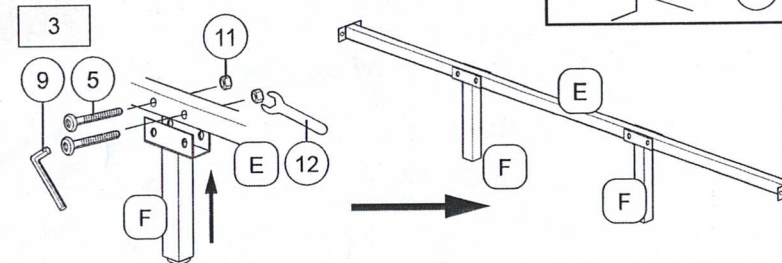
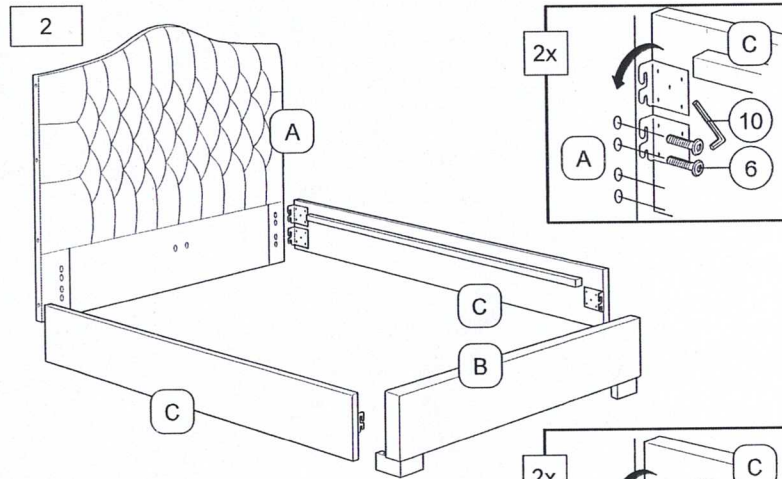
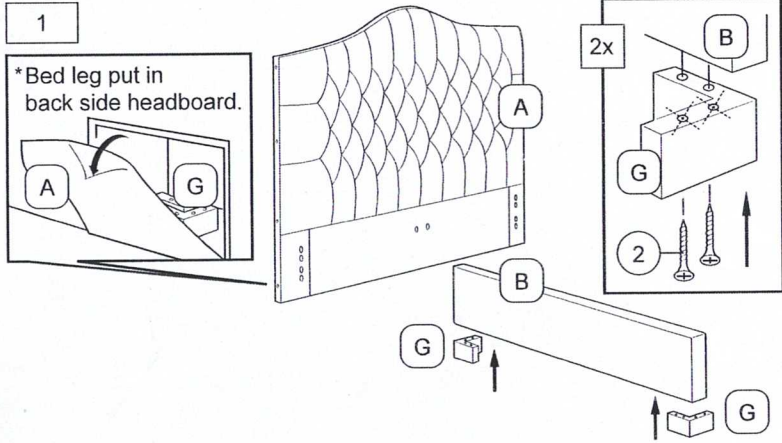

No	Part List	Qty.
A	Headboard	1 pc
B	Footboard	1 pc
C	Side Panel	2 pcs
D	Bed Slat (1 Set)	13 pcs
E	Bed Center Rail	1 pc
F	Bed Center Rail Support	2 pcs
G	Bed Leg	2 pcs
H	Wing	2 pcs

No	Hardware List	Qty.
1	CSK M4 x 32mm	8 pcs
2	CSK M4 x 45mm	4 pcs
3	JCBC M6 x 30mm	4 pcs
4	JCBC M6 x 35mm	8 pcs
5	JCBC M6 x 45mm	4 pcs
6	JCBB M8 x 20mm	12 pcs
7	M6 Flat Washer	8 pcs
8	M6 Spring Washer	8 pcs
9	Allen Key M4	1 pc
10	Allen Key M5	1 pc
11	M6 Hex Nuts	4 pcs
12	M6 Spanner	1 pc

Read this instruction carefully. Remove all wrapping material, staples and straps from the carton. See hardware and furniture part list for guidance. Be sure you have all wooden furniture parts on a clean and flat soft surface, such as a carpet or rug, to prevent from being scratched.

CAUTION :

1. Do not FULLY - TIGHTEN the nut or screw until all is ready to assemble.
2. Do not OVER - TIGHTEN the nut or screw to avoid causing damages to the thread.
3. Keep all hardware part out reach of children.

