

# Assembly Instruction

Model : TV 23001

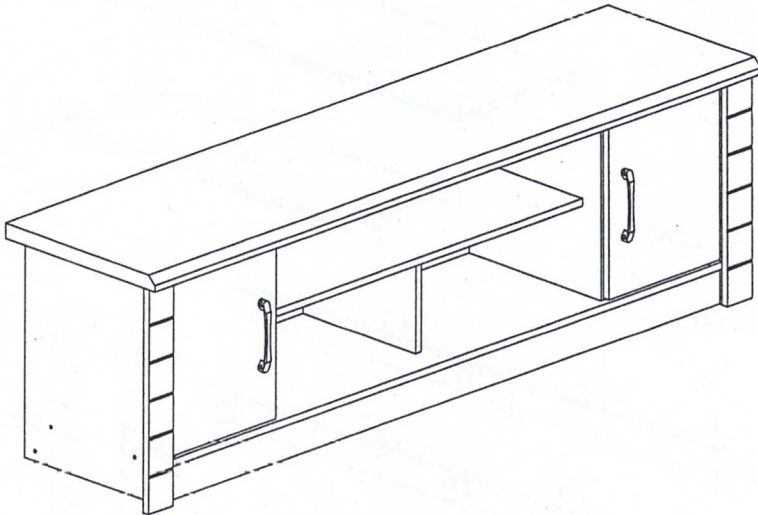

Hardware List			
Nu.	SHAPE	DESCRIPTION	Qty.
A		8x25mm Dowel	38Pcs
B		15MM Myfix Minifix	13Sets
C		M3.5x16mm Screw	14Pcs
D		M4x45mm Screw	18Pcs
E		2 Pin Magnet	2Sets
F		MT Stopper	4Pcs
G		Handle KT59.128	2Pcs
H		M4x25mm Screw	4Pcs
I		5/8 Nail With Pin	6Pcs
J		6/8 Power Pin	30Pcs
K		Sticker	8Pcs

## Part List

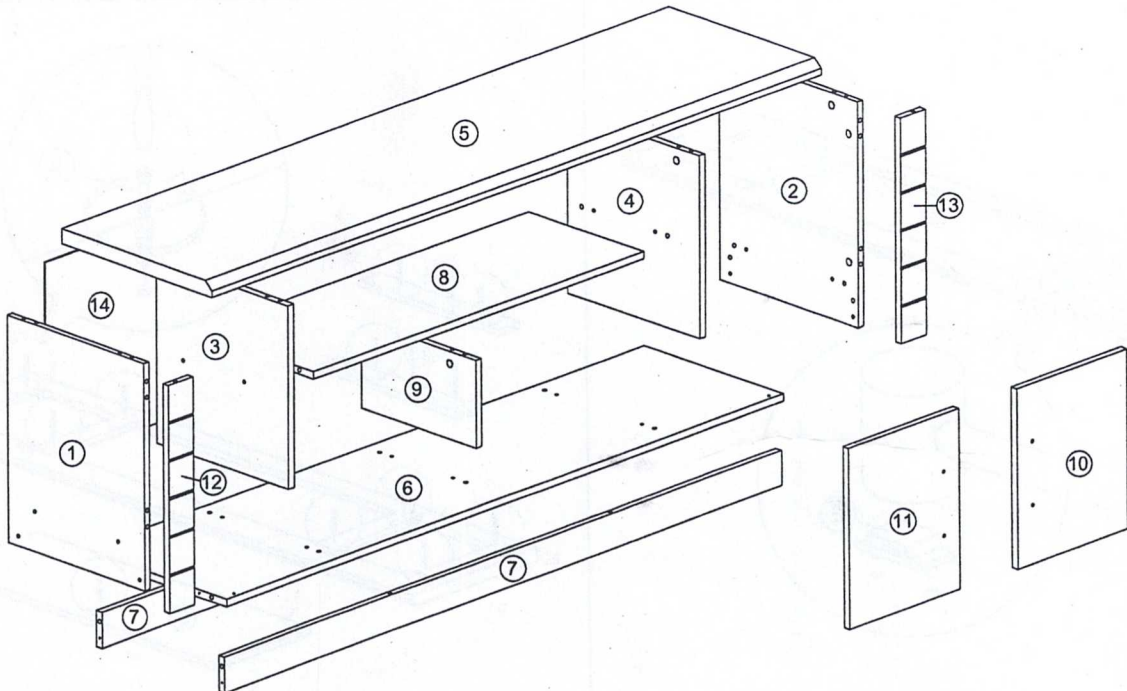

# Assembly Instruction

## Step 1

A		8x25mm Dowel	38Pcs
---	-----------------------------------------------------------------------------------	--------------	-------

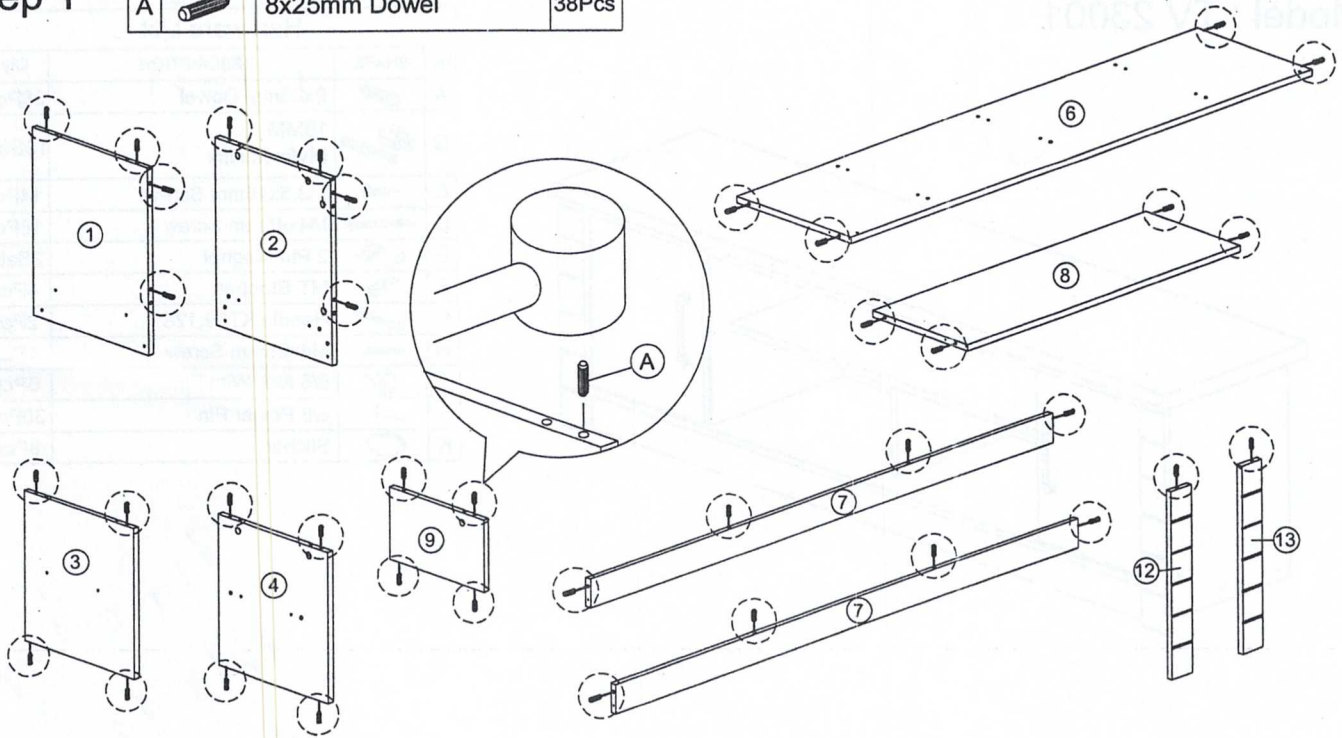

## Step 2

E		2 Pin Magnet	2Pcs
---	-------------------------------------------------------------------------------------	--------------	------

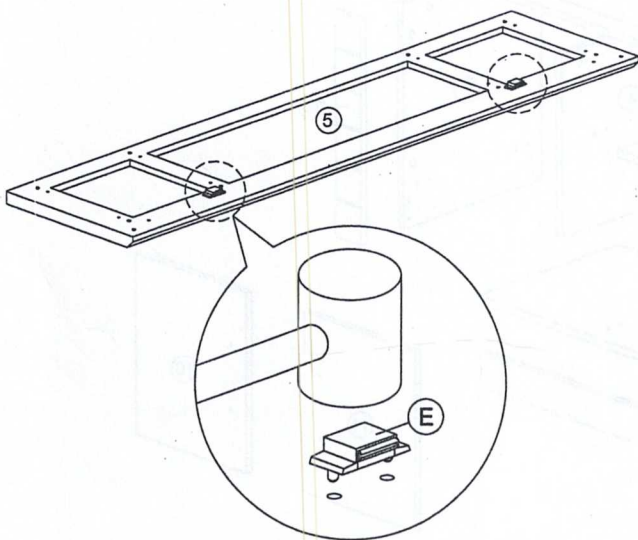

## Step 3

B		Myfix	13Pcs
---	---------------------------------------------------------------------------------------	-------	-------

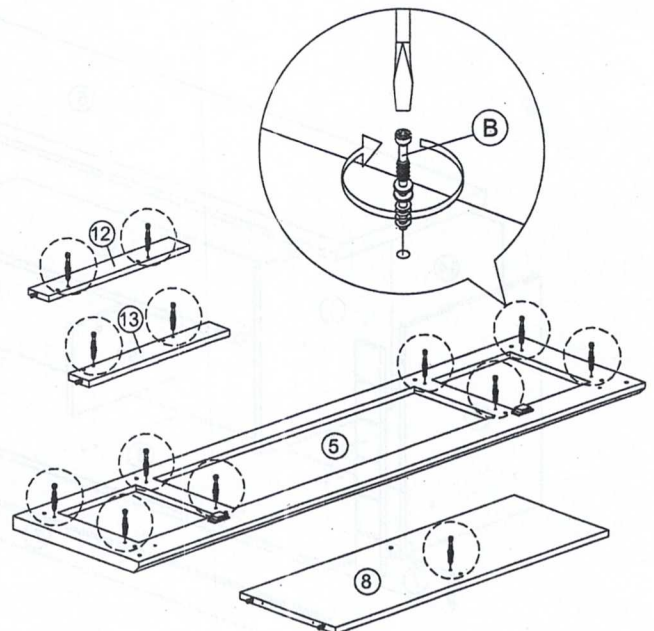

# Assembly Instruction

Step 4

B  Minifix 4Pcs

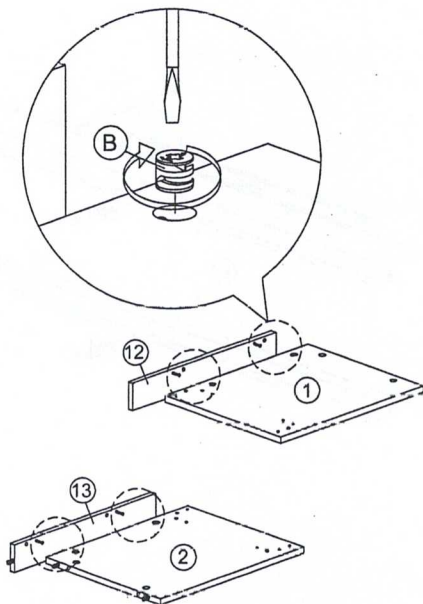

Step 5

D  M4x45mm Screw 2Pcs

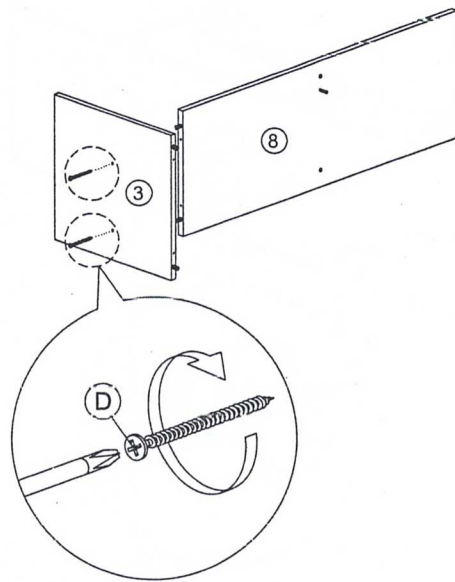

Step 6

D  M4x45mm Screw 2Pcs

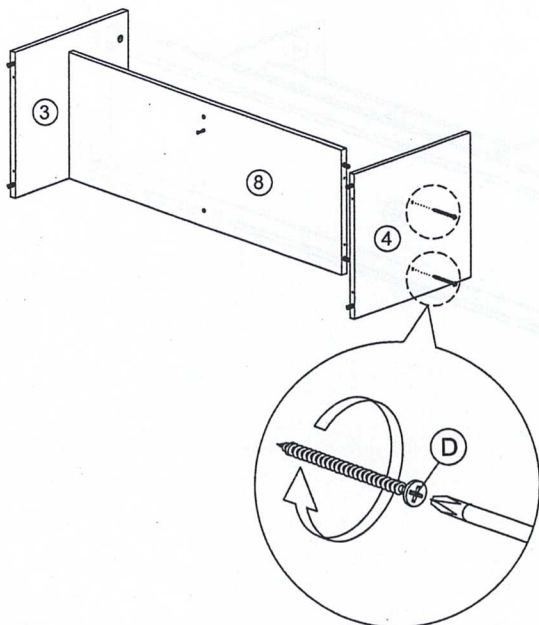

Step 7

B  Minifix 1Pc

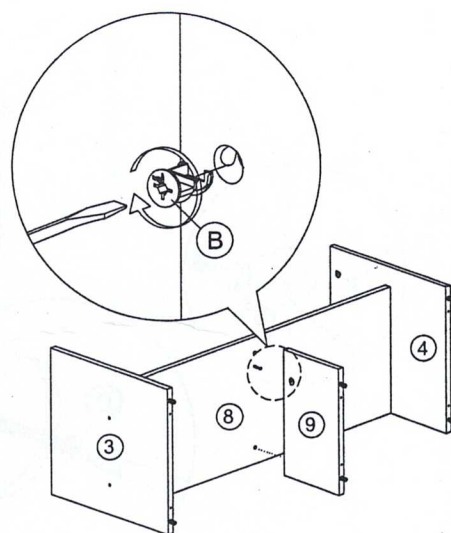



# Assembly Instruction

Step 8

D  M4x45mm Screw 6Pcs

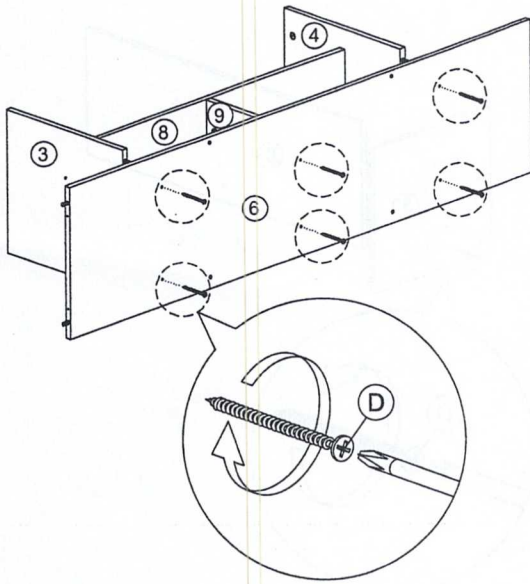

Step 9

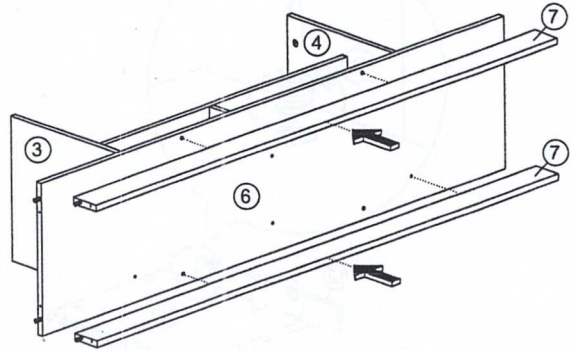

Step 10

D  M4x45mm Screw 4Pcs

K  Sticker 4Pcs

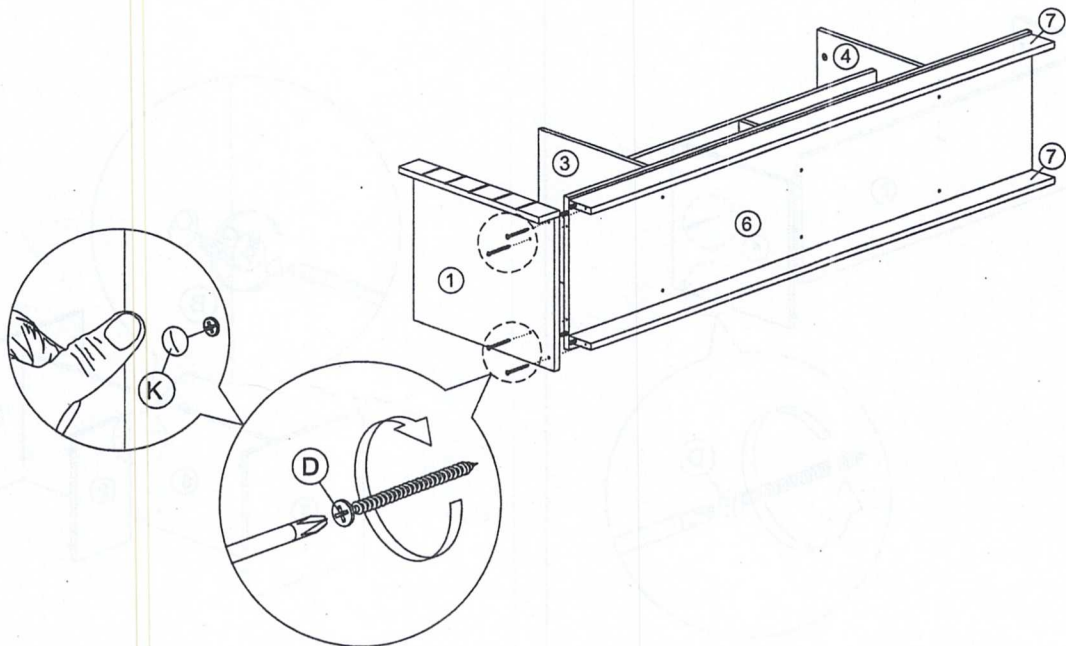

# Assembly Instruction

Step 11

D		M4x45mm Screw	4Pcs	K		Sticker	4Pcs
---	-----------------------------------------------------------------------------------	---------------	------	---	-----------------------------------------------------------------------------------	---------	------

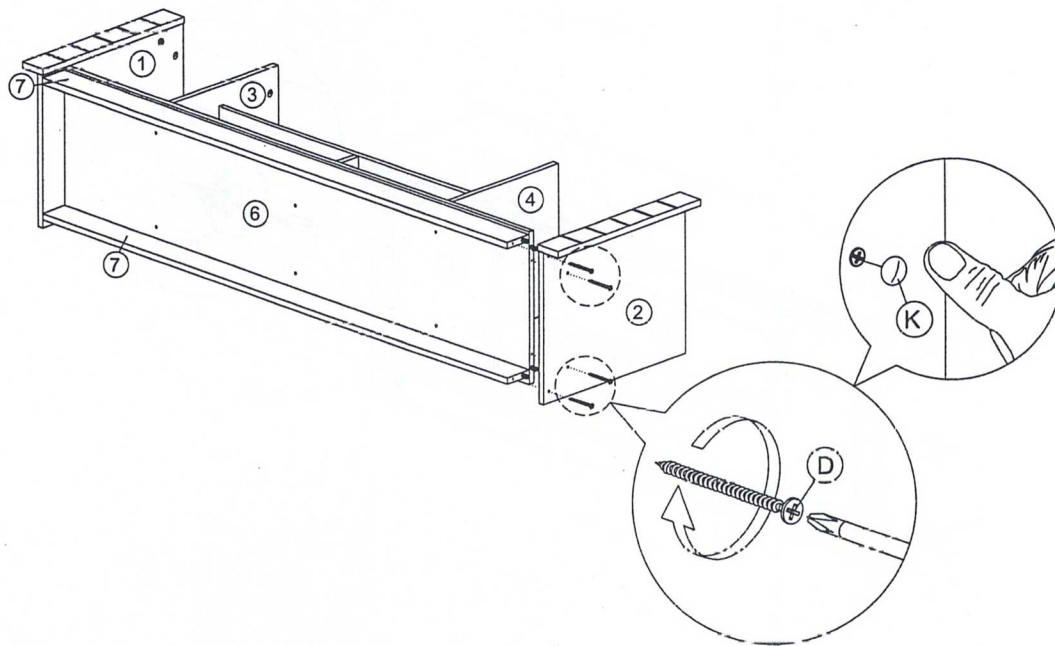

Step 12

I		5/8 Nail With Pin	6Pcs
---	-------------------------------------------------------------------------------------	-------------------	------

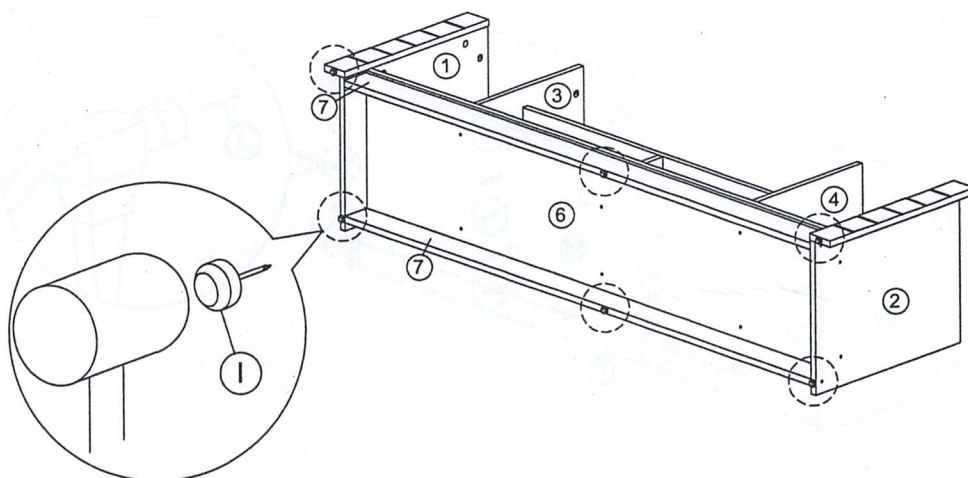

# Assembly Instruction

Step 13

B



Minifix

8Pcs

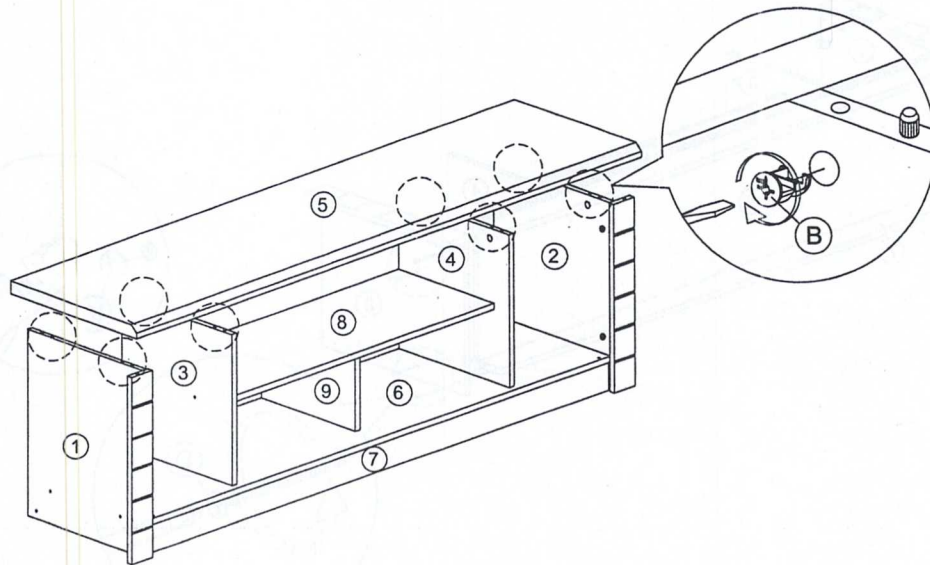

Step 14

J



6/8 Power Pin

30Pcs

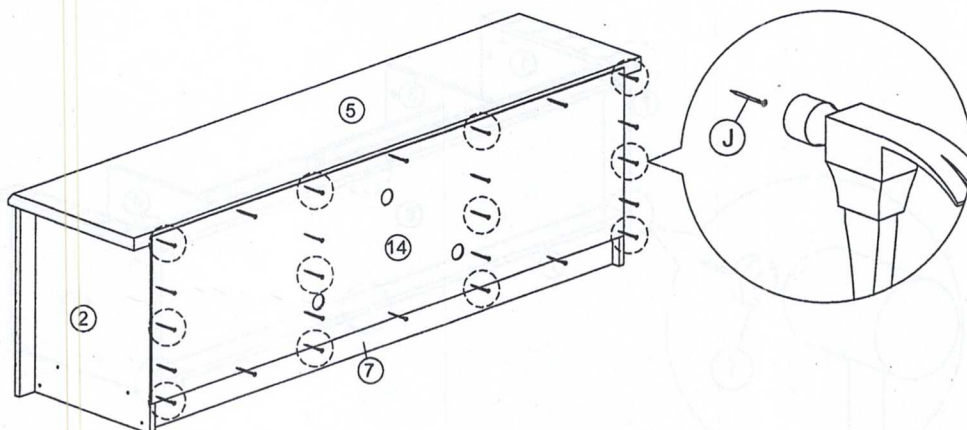





# Assembly Instruction

Step 15

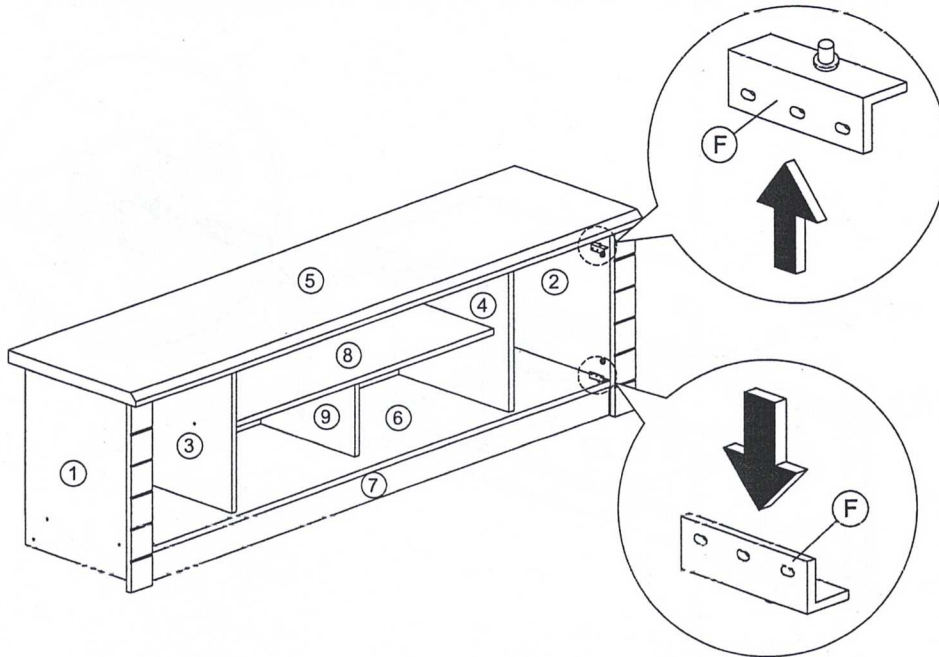
F		MT Stopper	2Pcs
---	-----------------------------------------------------------------------------------	------------	------



Step 16

C		M3.5x16mm Screw	6Pcs
---	-------------------------------------------------------------------------------------	-----------------	------

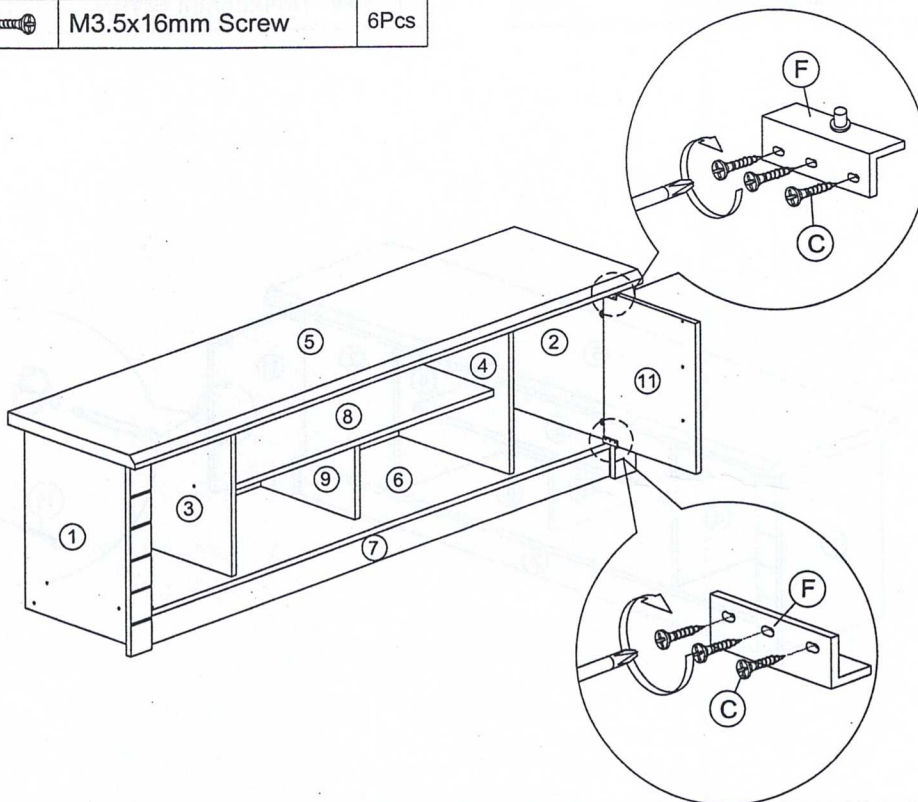

# Assembly Instruction

Step 16

C		M3.5x16mm Screw	1Pc
---	-----------------------------------------------------------------------------------	-----------------	-----

E		2 Pin Magnet	1Pc
---	-----------------------------------------------------------------------------------	--------------	-----

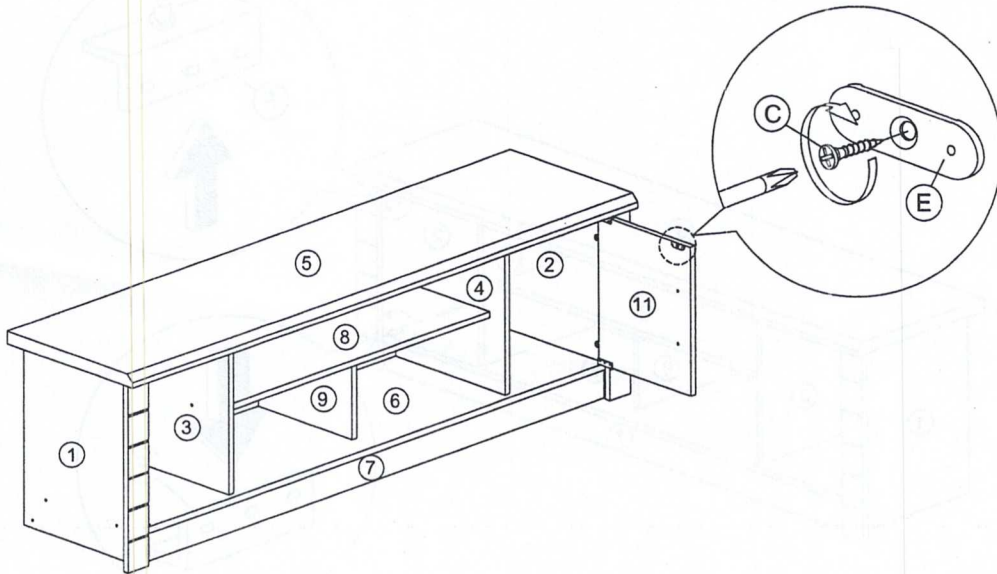

Step 17

G		Handle KT59.128	1Pc
---	-------------------------------------------------------------------------------------	-----------------	-----

H		M4x25mm Screw	2Pcs
---	-------------------------------------------------------------------------------------	---------------	------

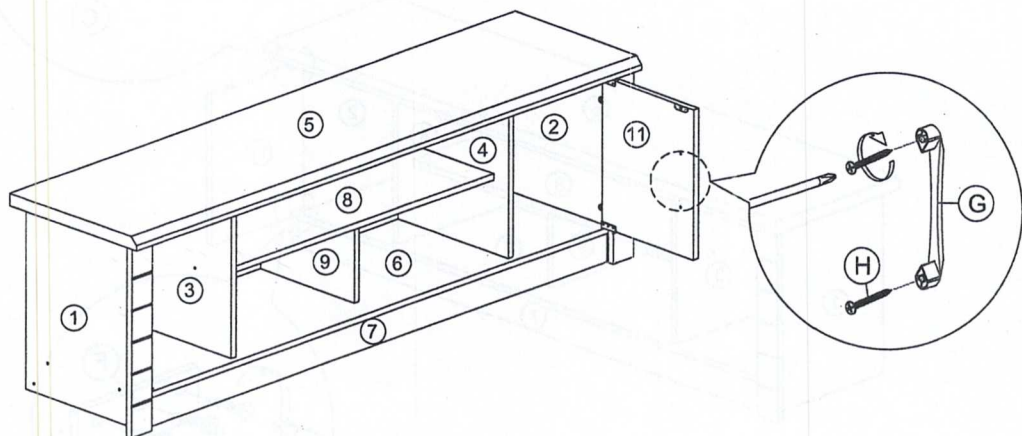





# Assembly Instruction

Step 18

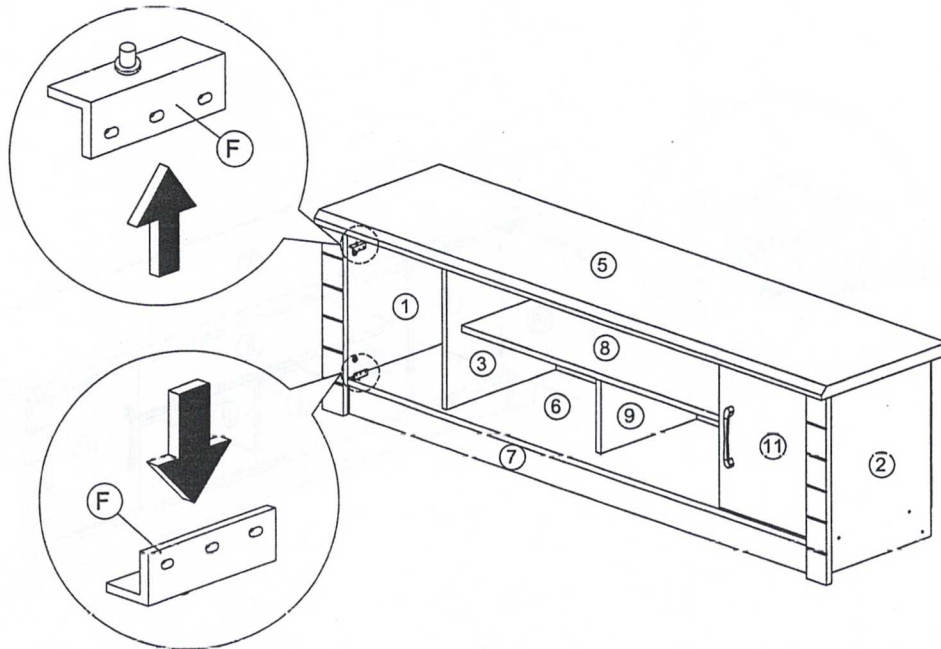
F		MT Stopper	2Pcs
---	-----------------------------------------------------------------------------------	------------	------



Step 19

C		M3.5x16mm Screw	6Pcs
---	-------------------------------------------------------------------------------------	-----------------	------

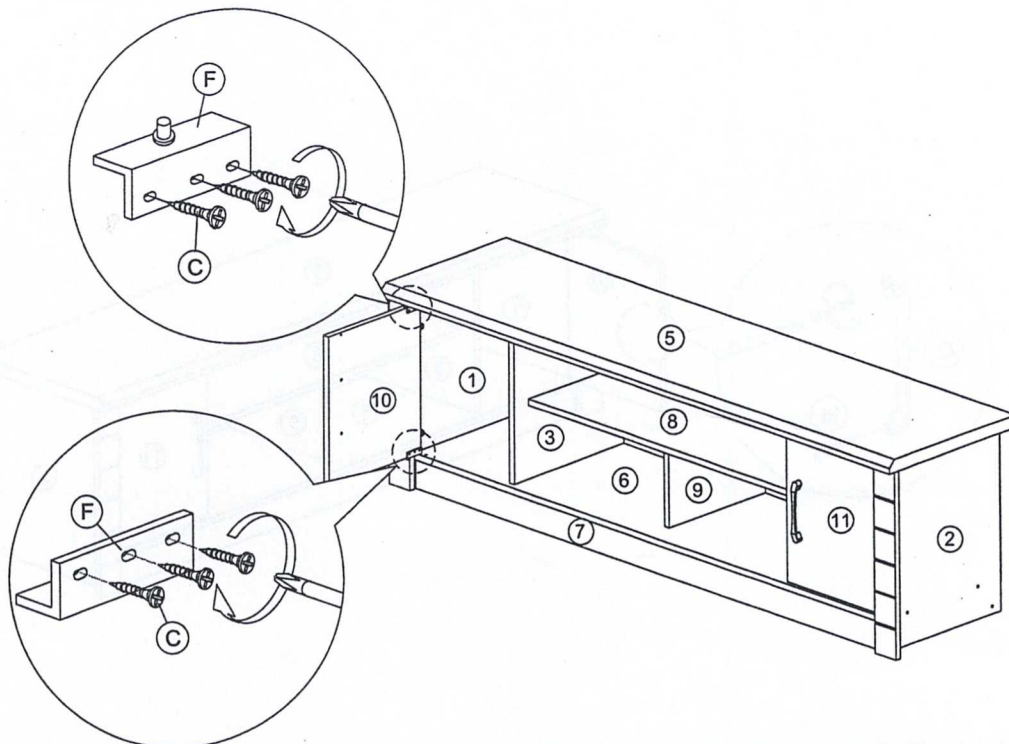

# Assembly Instruction

Step 20

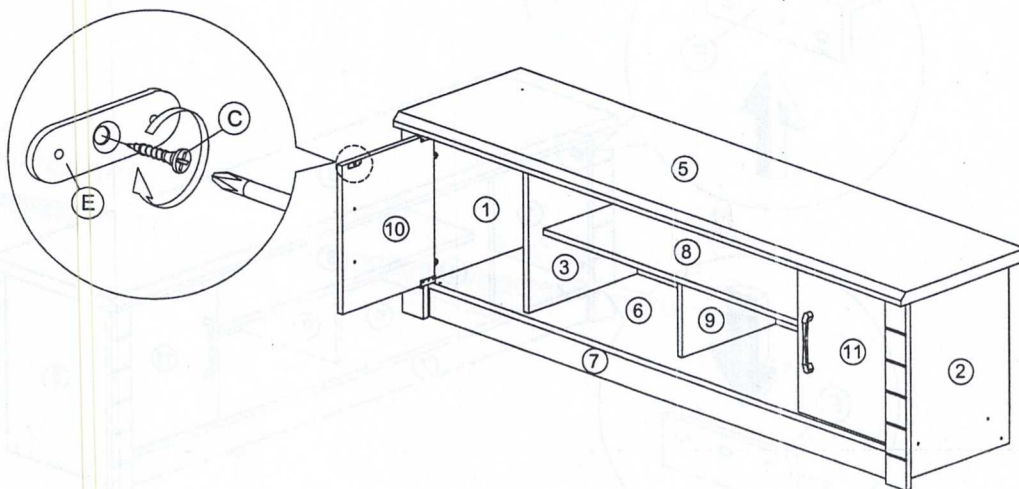
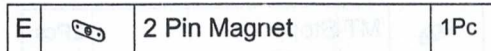
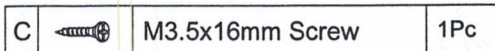

Step 21

