

# Assembly Instruction

Model : TV 22209

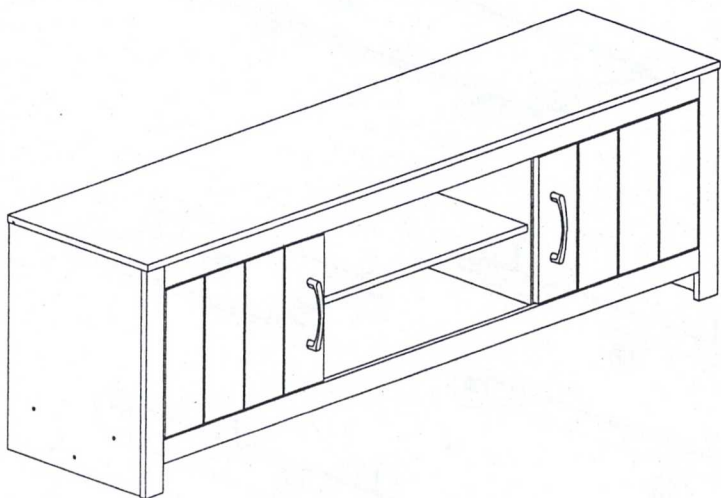

Hardware List			
No.	SHAPE	DESCRIPTION	Qty.
A		8x25mm Dowel	43Pcs
B		15MM Myfix Minifix	16Sets
C		M3.5x16mm Screw	14Pcs
D		M4x45mm Screw	10Pcs
E		MT Stopper	4Pcs
F		2 Pin Magnet	2Sets
G		Shelf Support	8Pcs
H		Handle OS128	2Pcs
I		M4x28mm Screw	4Pcs
J		Sticker	6Pcs
K		5/8 Nail With Pin	6Pcs

## Part List

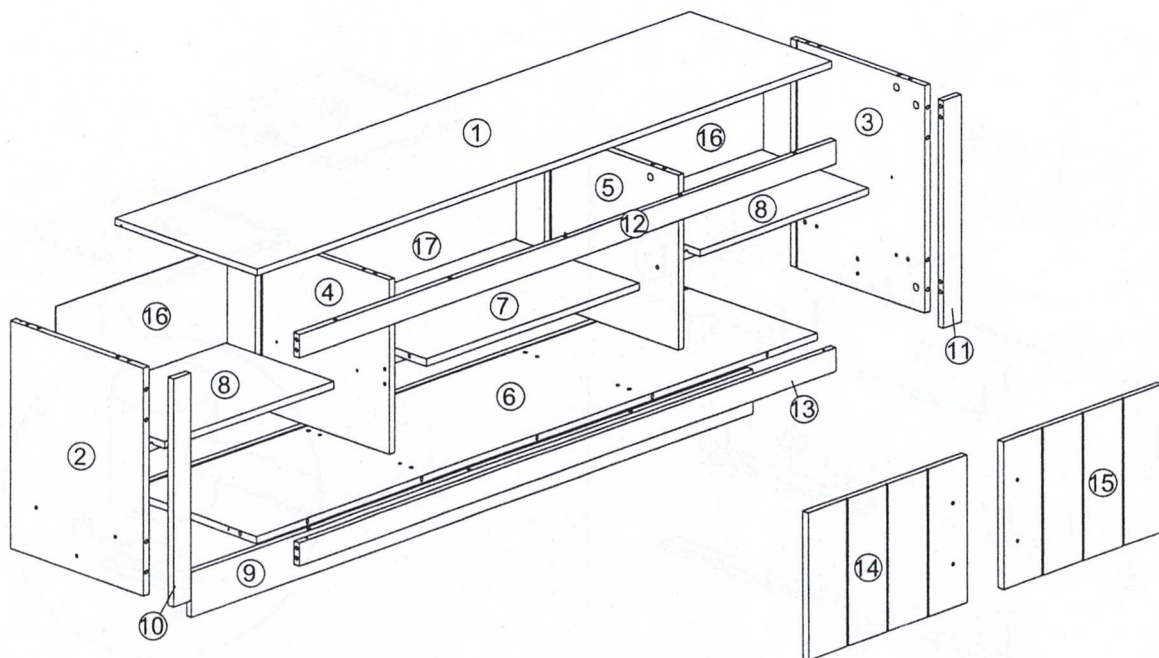

# Assembly Instruction

## Step 1

A		8x25mm Dowel	43Pcs
---	---	--------------	-------

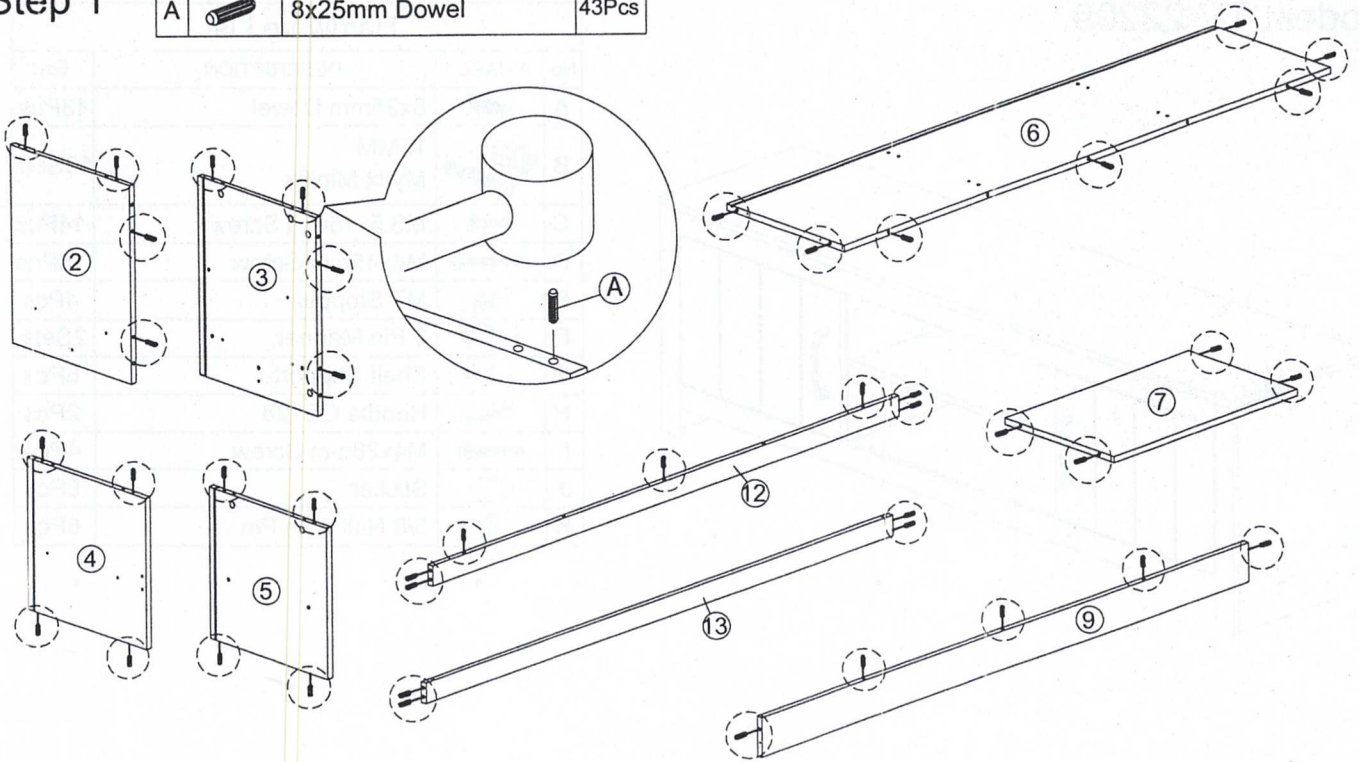

## Step 2

B		Myfix	16Pcs
---	---	-------	-------

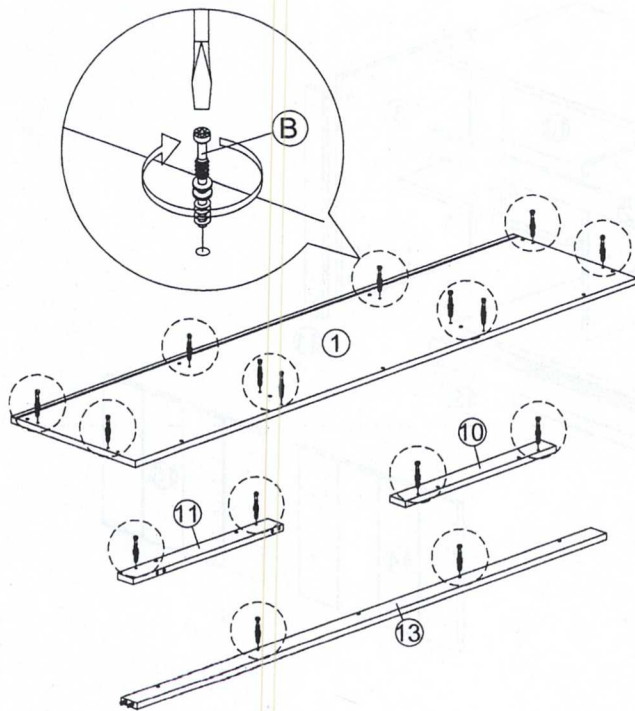

## Step 3

F		2 Pin Magnet	2Pcs
---	---	--------------	------

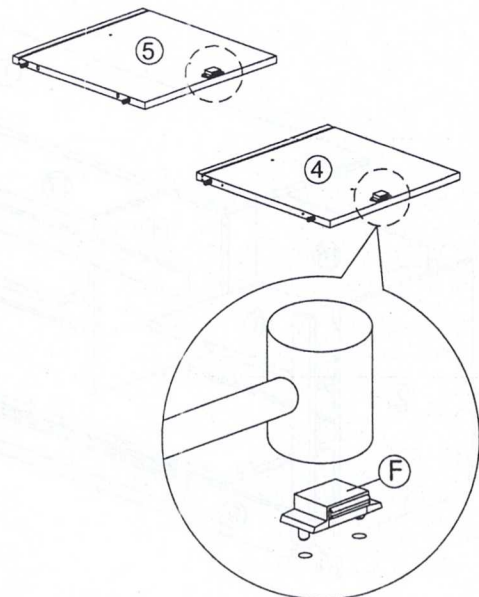

# Assembly Instruction

Step 4

B  Minifix 4Pcs

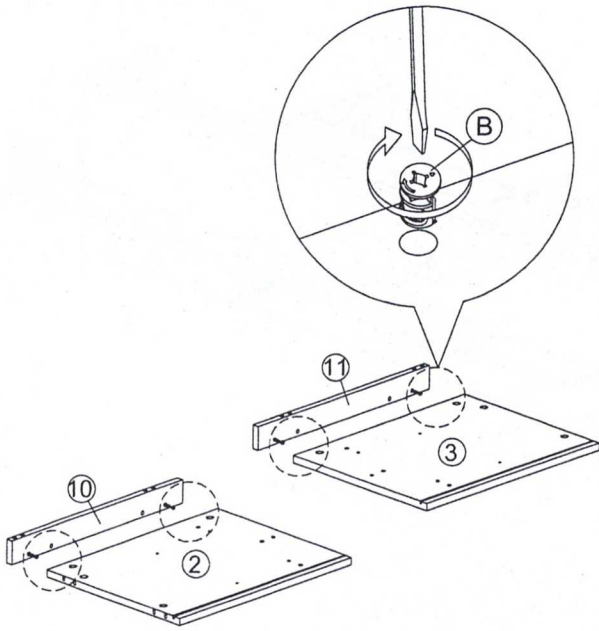

Step 5

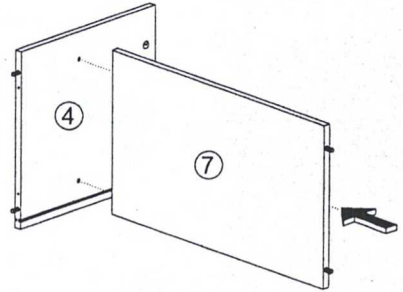

Step 6

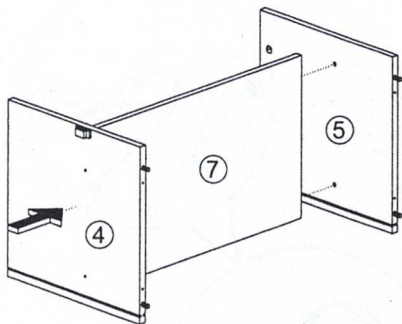

Step 7

D  M4x45mm Screw 4Pcs

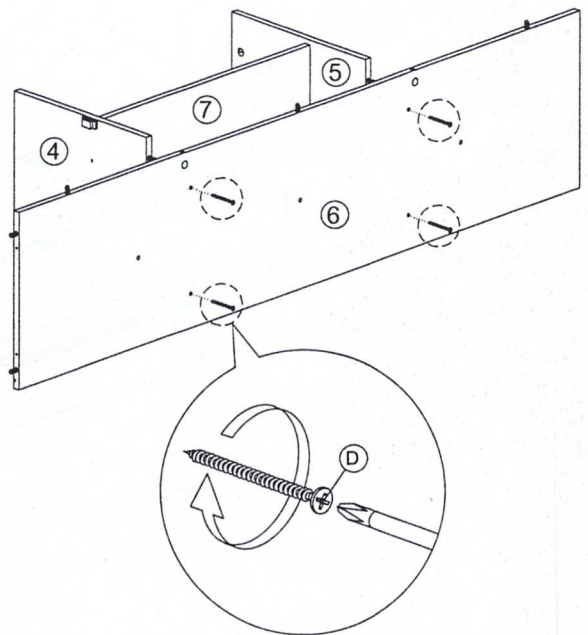

# Assembly Instruction

Step 8

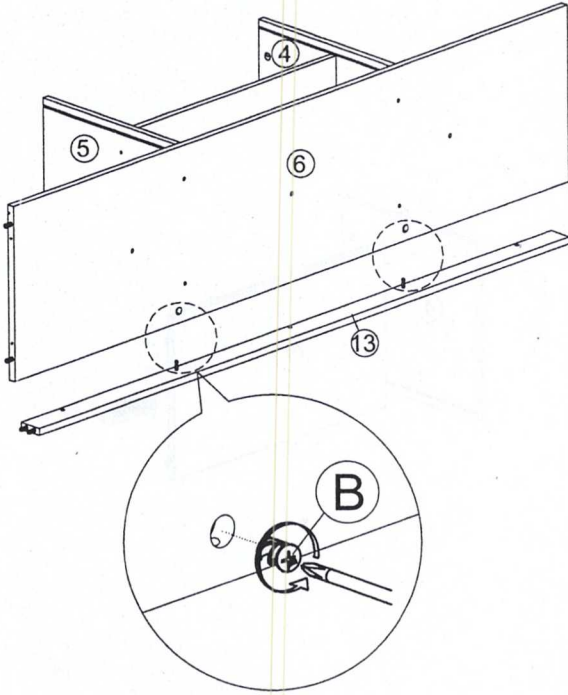

B		Minifix	2Pcs
---	---	---------	------

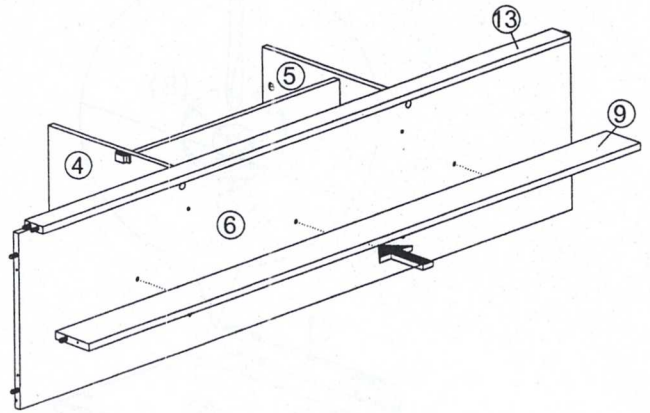

Step 9



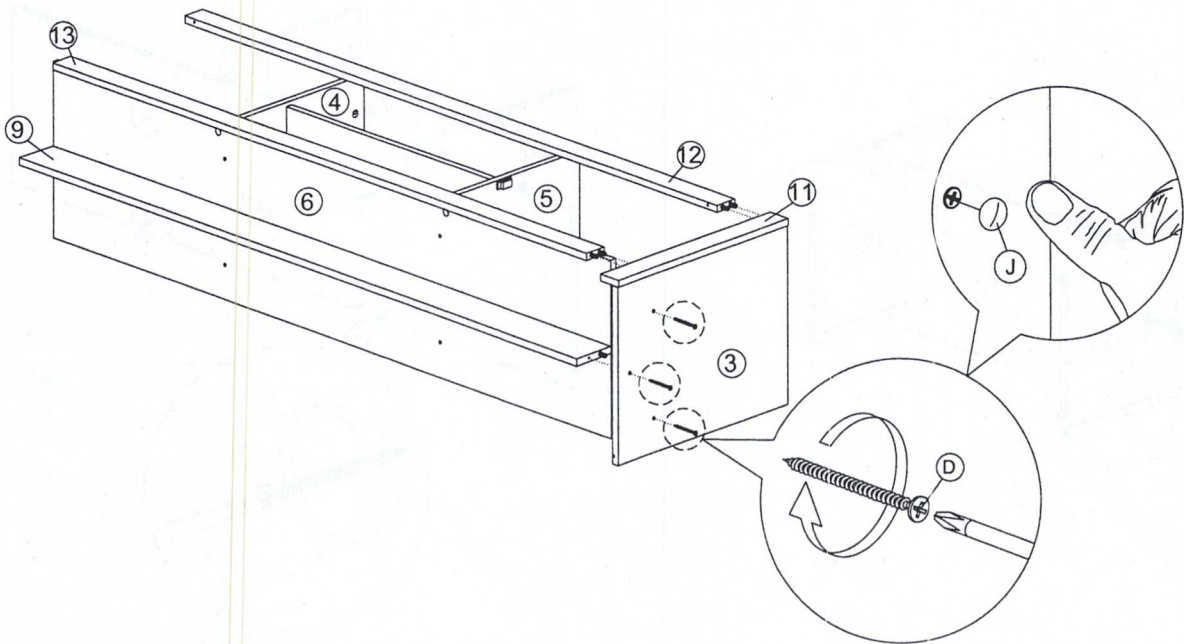

Step 10

D		M4x45mm Screw	3Pcs
J		Sticker	3Pcs



# Assembly Instruction

## Step 11

D		M4x45mm Screw	3Pcs
J		Sticker	3Pcs

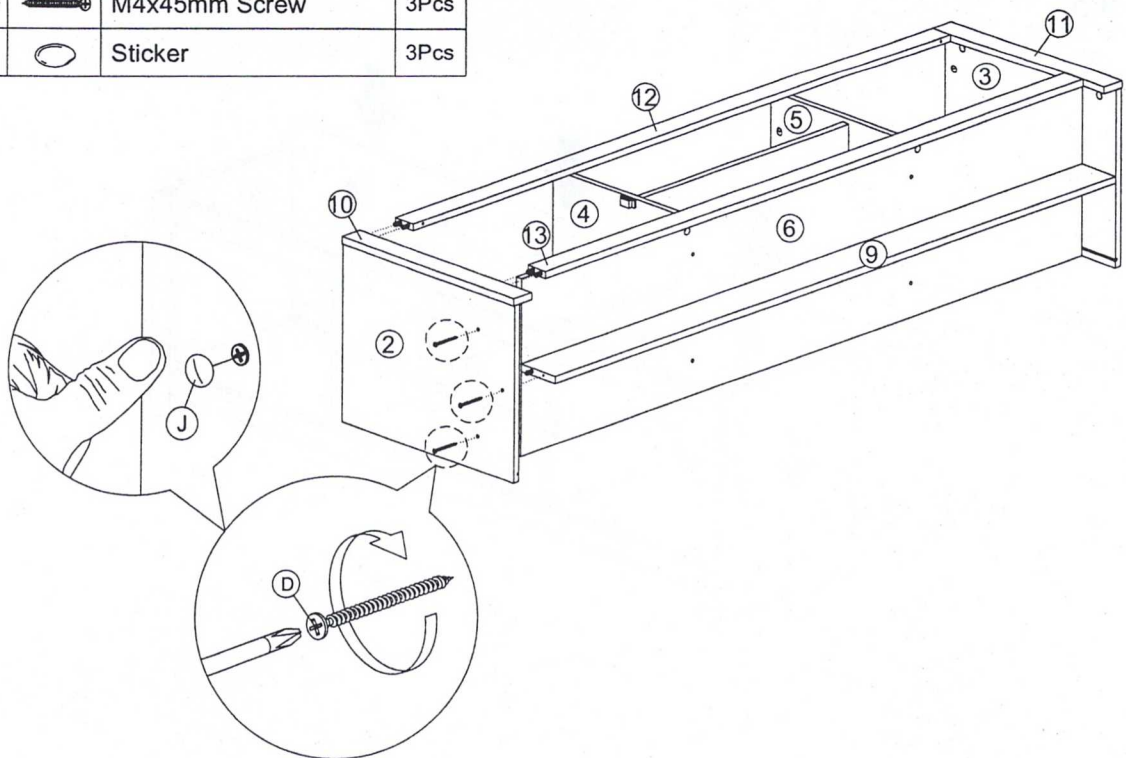

## Step 12

K		5/8 Nail With Pin	6Pcs
---	---	-------------------	------

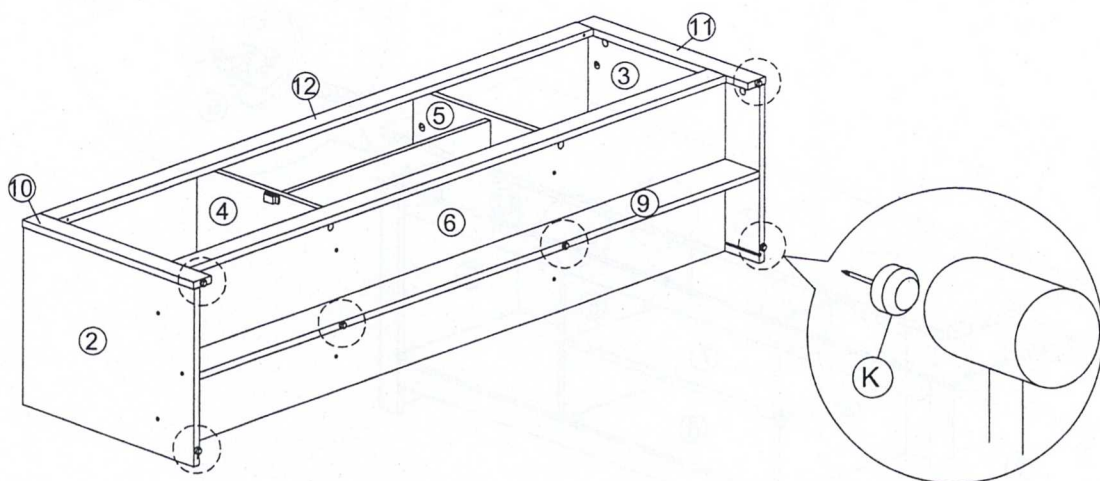

# Assembly Instruction

## Step 13

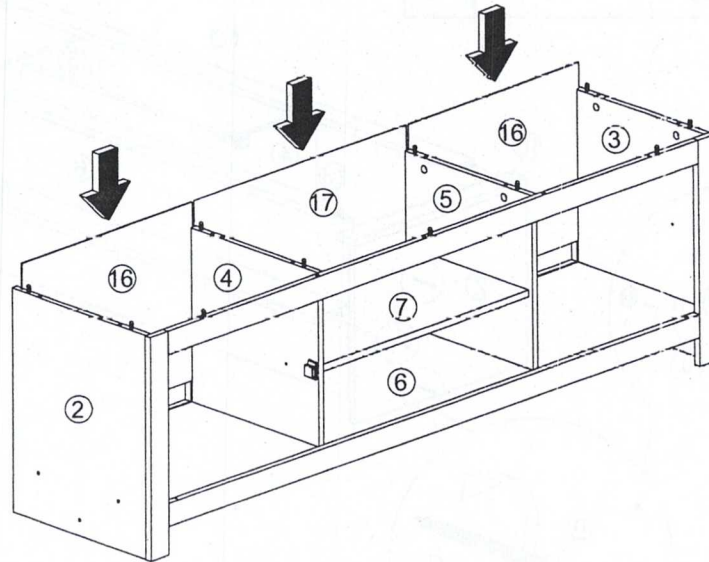

## Step 14

B  Minifix 10Pcs

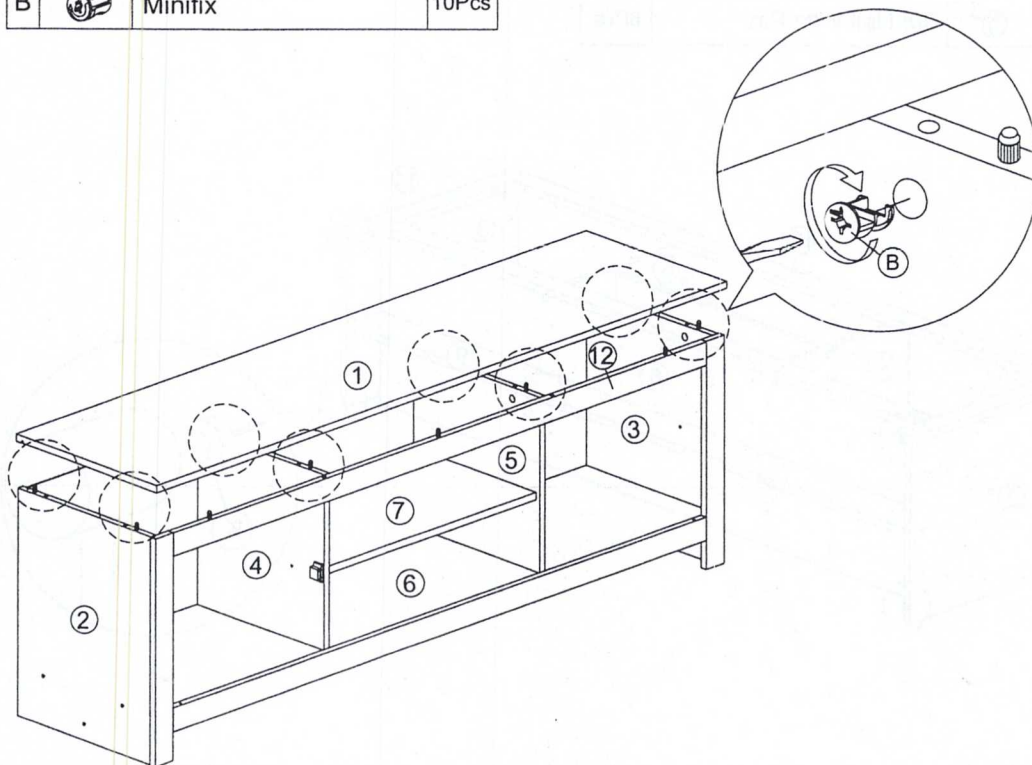

# Assembly Instruction

Step 15

G		Shelf Support	8Pcs
---	---	---------------	------

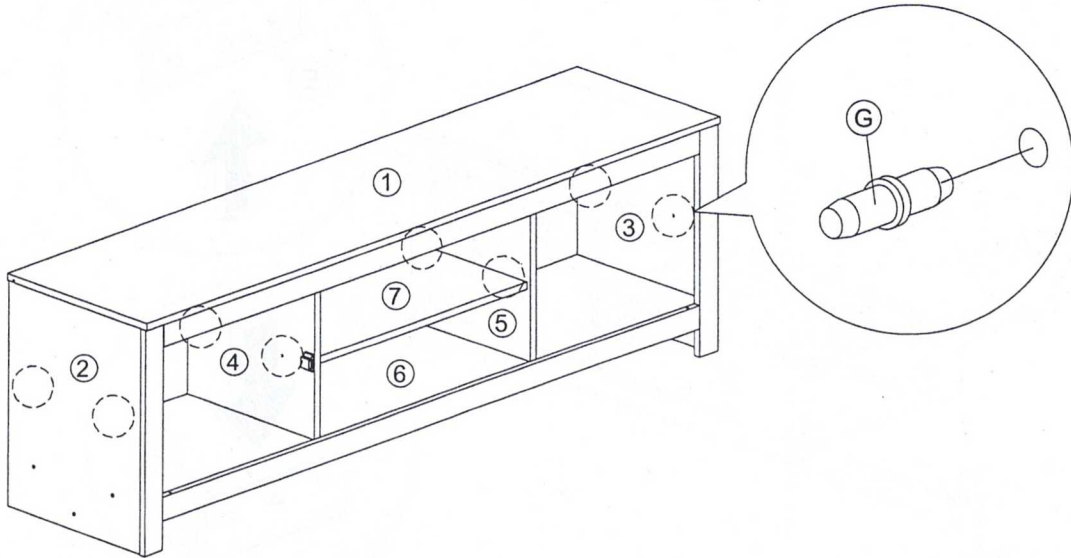

Step 16

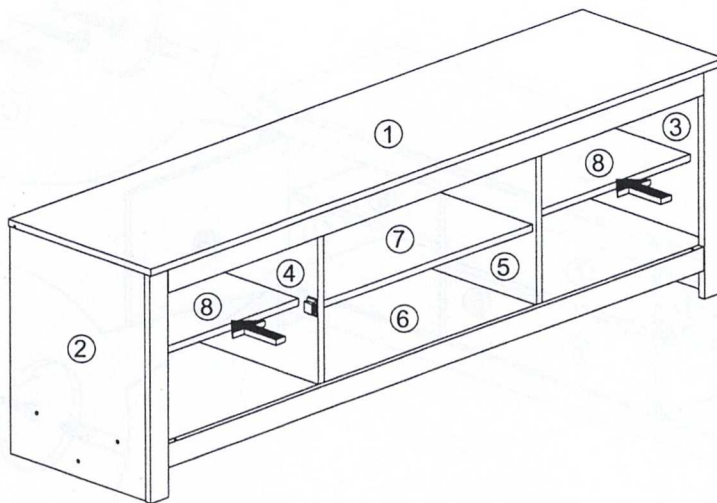

# Assembly Instruction

Step 17

E		MT Stopper	2Pcs
---	---	------------	------

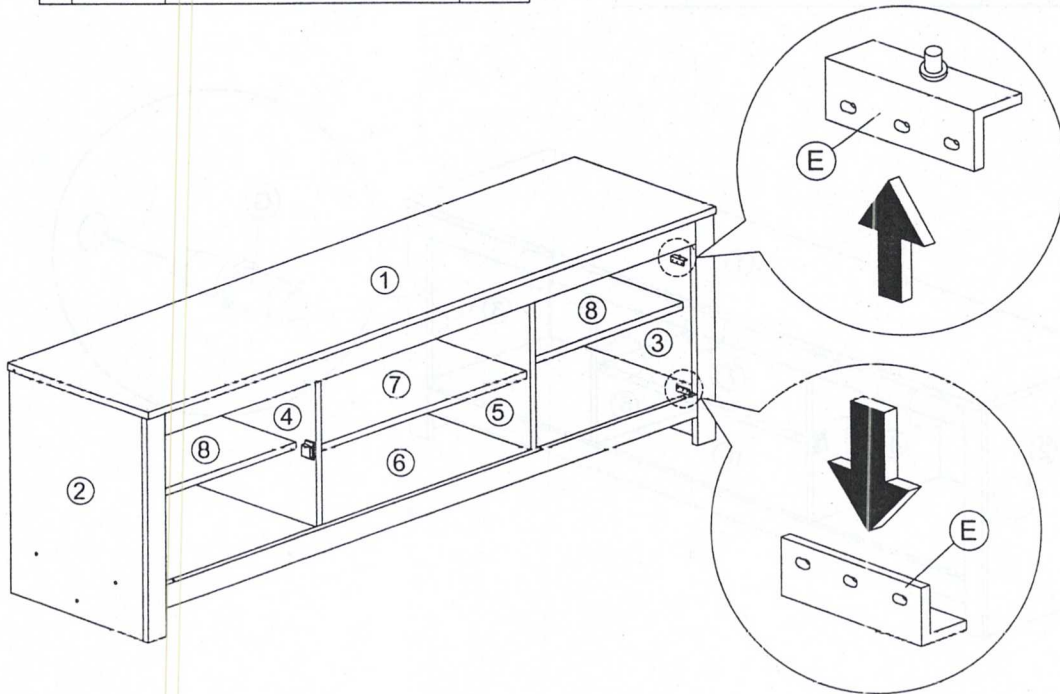

Step 18

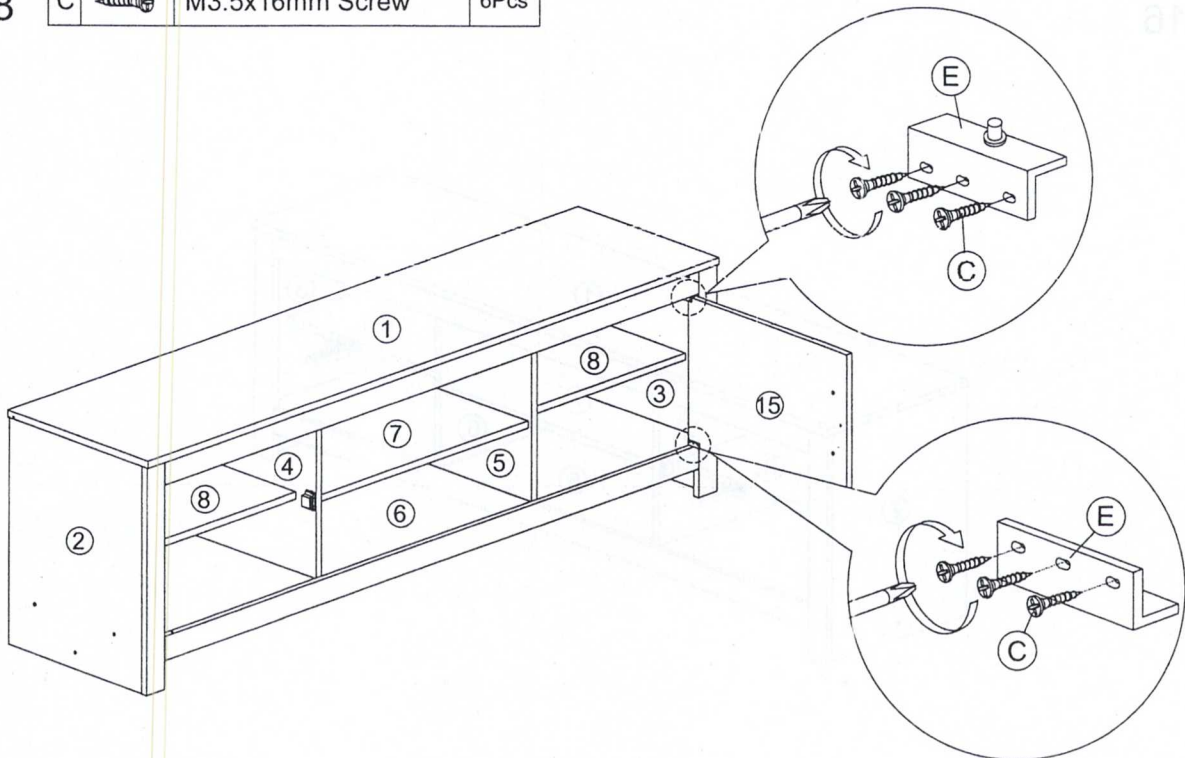

C		M3.5x16mm Screw	6Pcs
---	---	-----------------	------







# Assembly Instruction

## Step 19

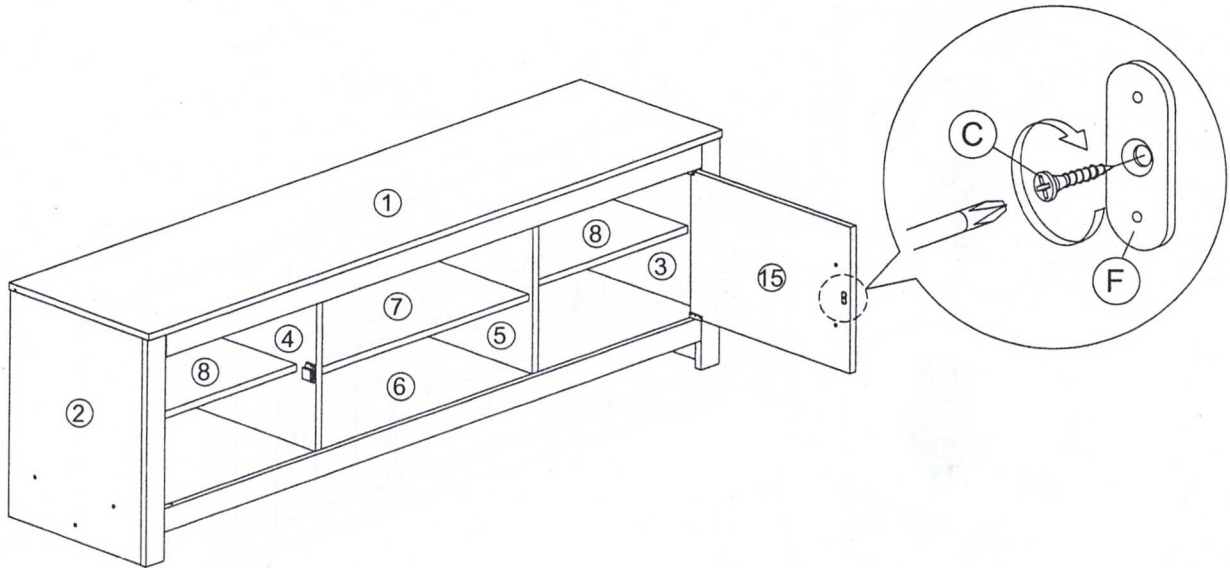
C		M3.5x16mm Screw	1Pc
F		2 Pin Magnet	1Pc



## Step 20

H		Hsndle OS128	1Pc
I		M4x28mm Screw	2Pcs

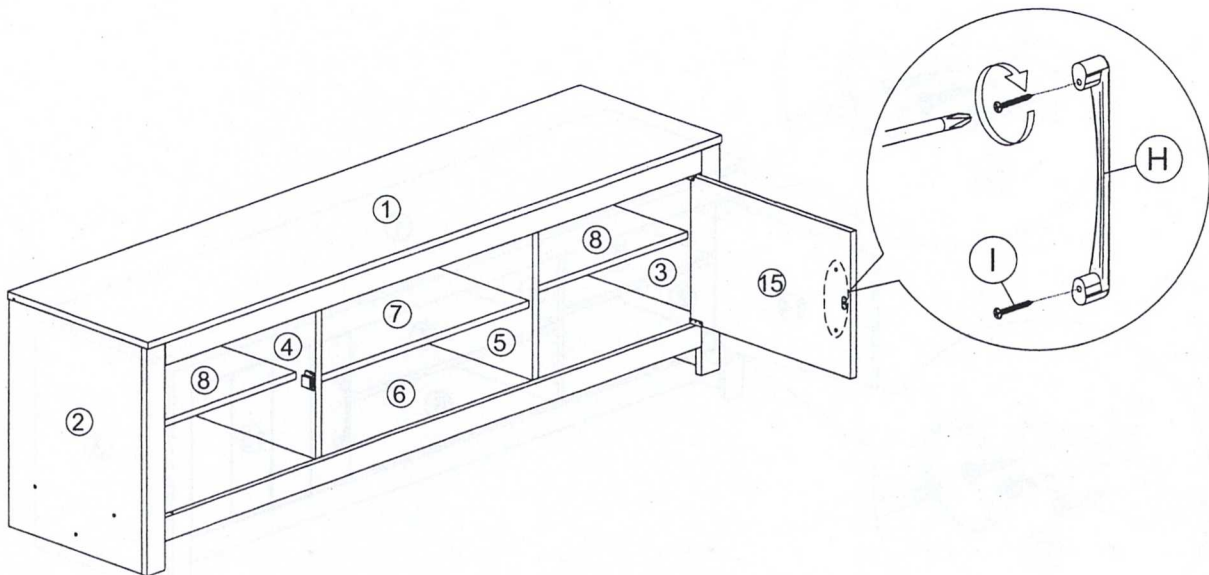

# Assembly Instruction

Step 21

E



MT Stopper

2Pcs

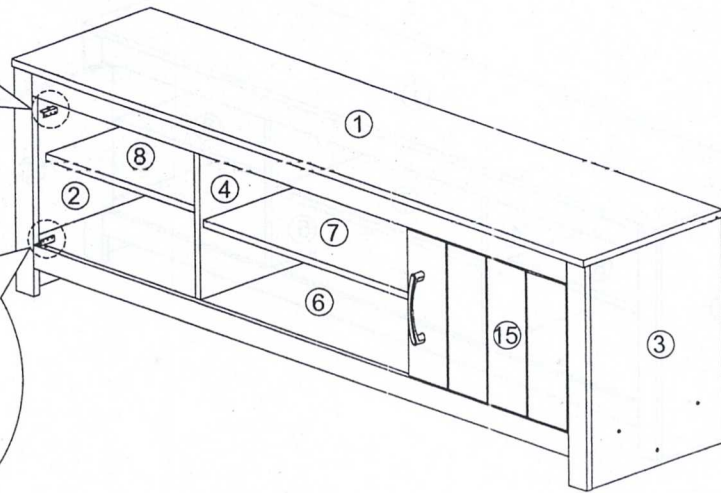
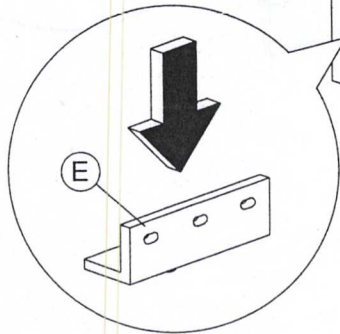
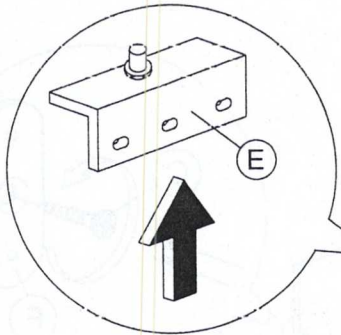

Step 22

C



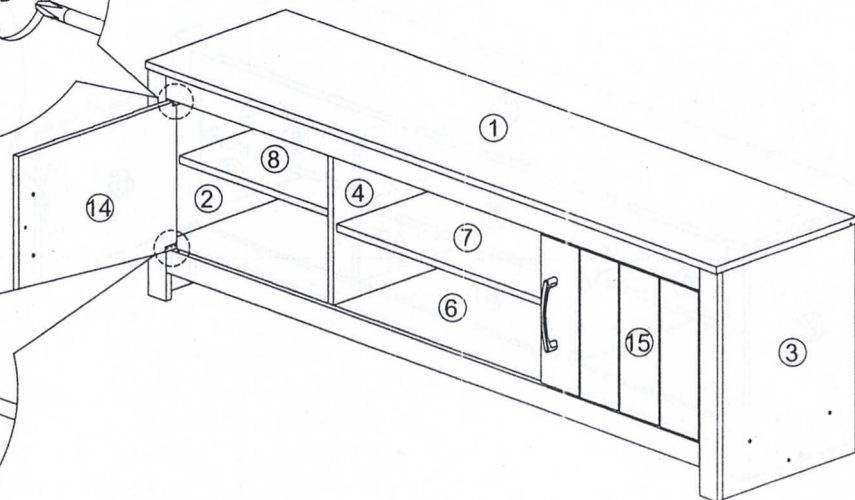
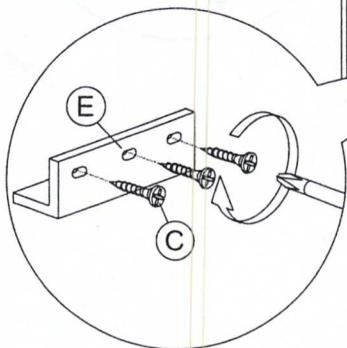
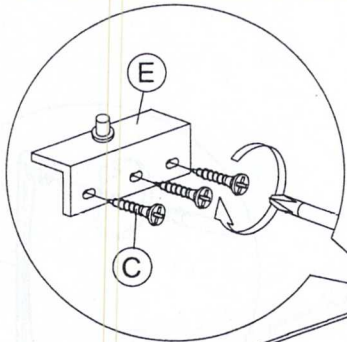

M3.5x16mm Screw

6Pcs





# Assembly Instruction

## Step 23

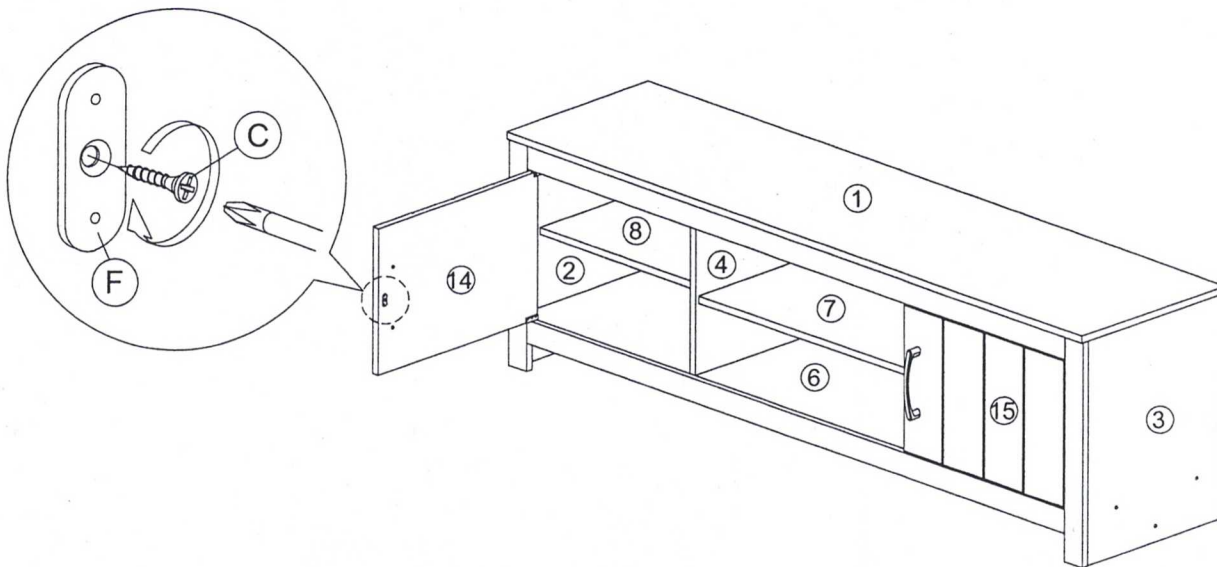
C		M3.5x16mm Screw	1Pc
F		2 Pin Magnet	1Pc



## Step 24

H		Hsndle OS128	1Pc
I		M4x28mm Screw	2Pcs

