

Assembly Instruction

Model : CF 23003



Hardware List			
No.	SHAPE	DESCRIPTION	Qty.
A		8x25mm Dowel	22Pcs
B		15MM Myfix Minifix	6Sets
C		M3.5x16mm Screw	30Pcs
D		M4x45mm Screw	6Pcs
E		2 Pin Magnet	2Sets
F		MT Stopper	2Pcs
G		2 Pin Stopper	2Pcs
H		Round Taper Leg 150mm	5Pcs

Part List

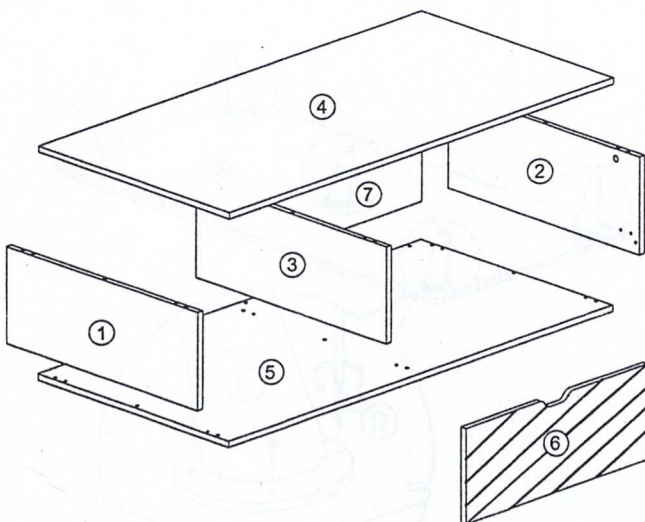

Step 1

A		8x25mm Dowel	22Pcs
---	--	--------------	-------

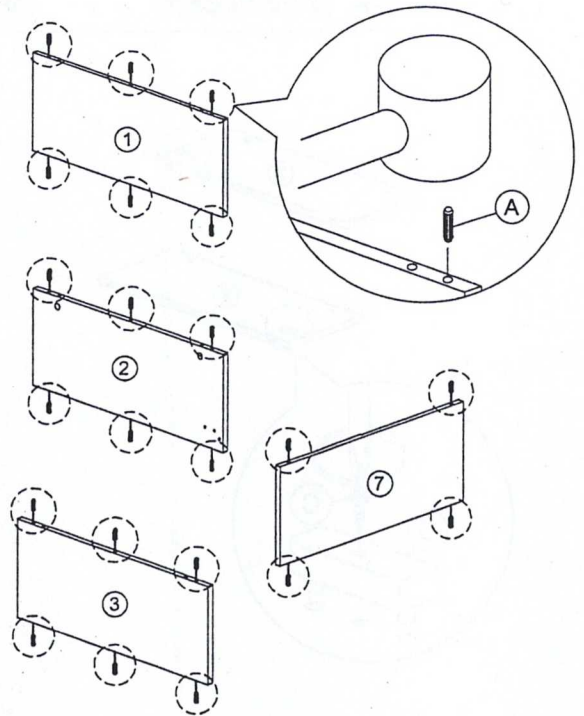

not to worry

Assembly Instruction

Step 2

E		2 Pin Magnet	2Pcs
---	---	--------------	------

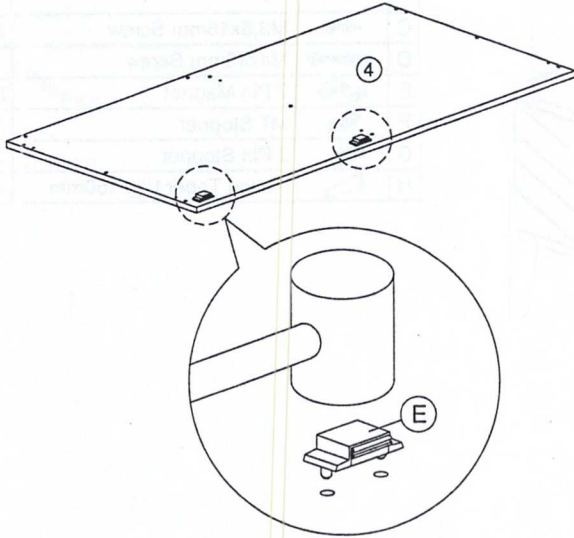

Step 3

B		Myfix	6Pcs
---	---	-------	------

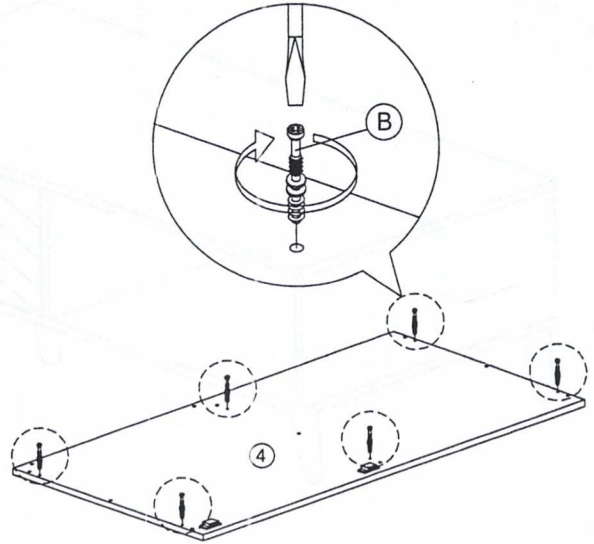

Step 4

C		M3.5x16mm Screw	2Pcs
G		2 Pin Stopper	2Pcs

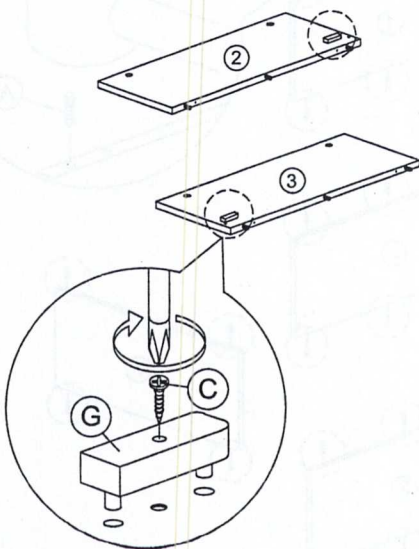

Step 5

C		M3.5x16mm Screw	20Pcs
H		Round Taper Leg 150mm	5Pcs

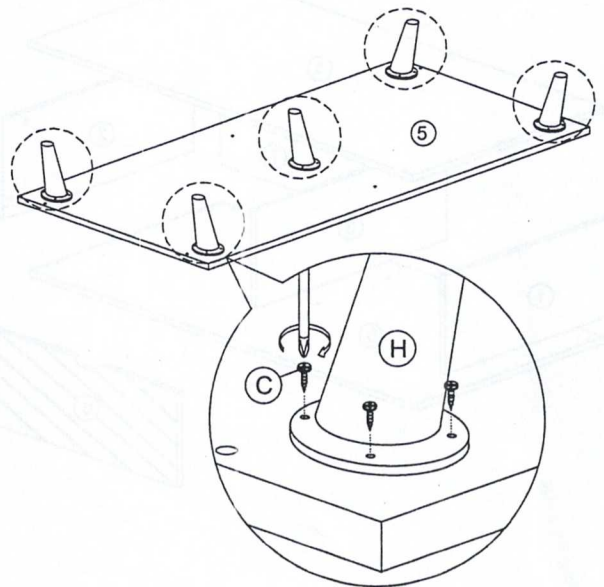

Assembly Instruction

Step 6

D  M4x45mm Screw 6Pcs

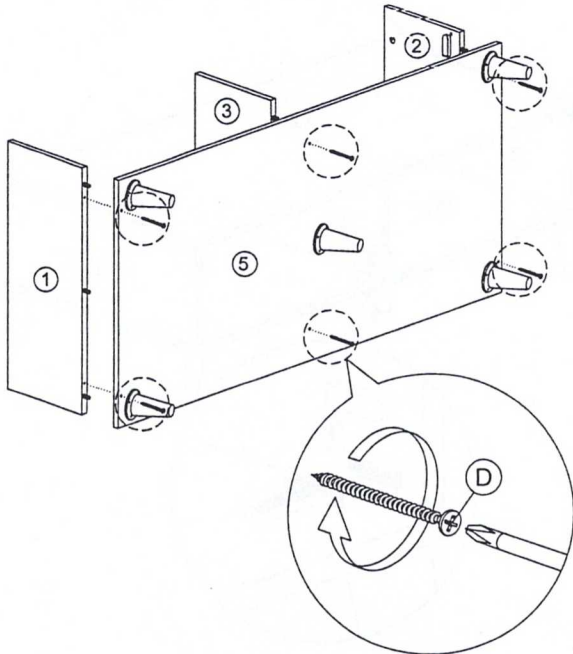

Step 7

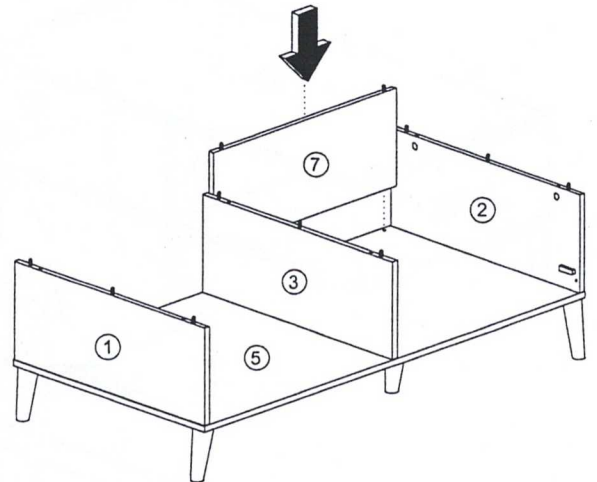

Step 8

B  Minifix 6Pcs

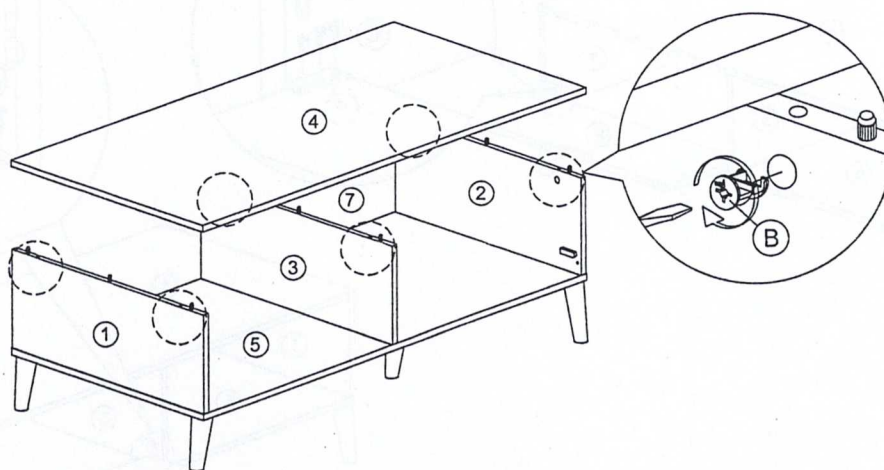

Assembly Instruction

Step 9

F		MT Stopper	2Pcs
---	---	------------	------

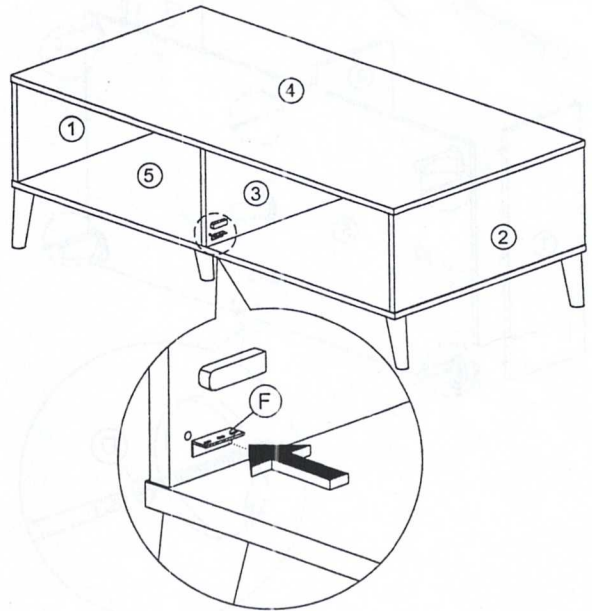
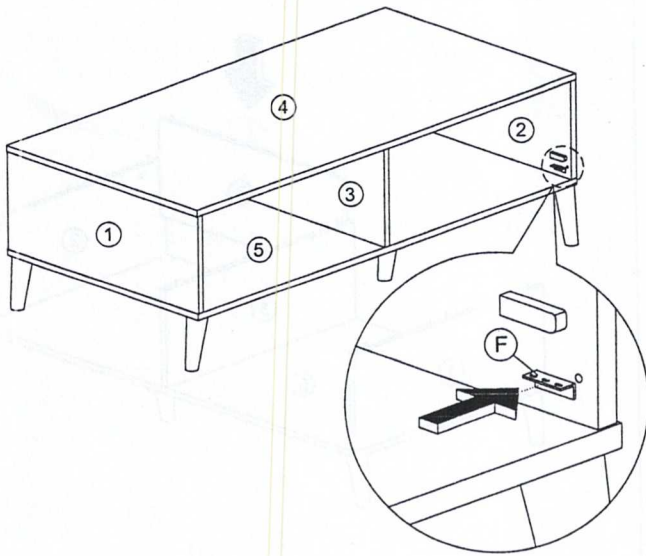

Step 10

C		M3.5x16mm Screw	6Pcs
---	---	-----------------	------

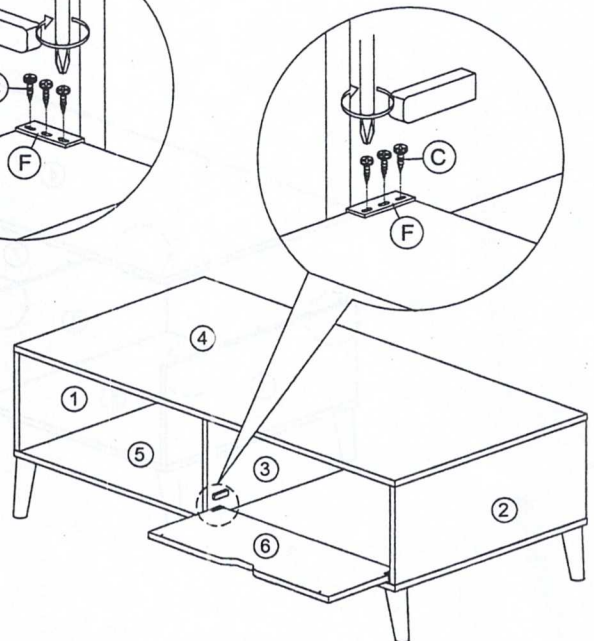
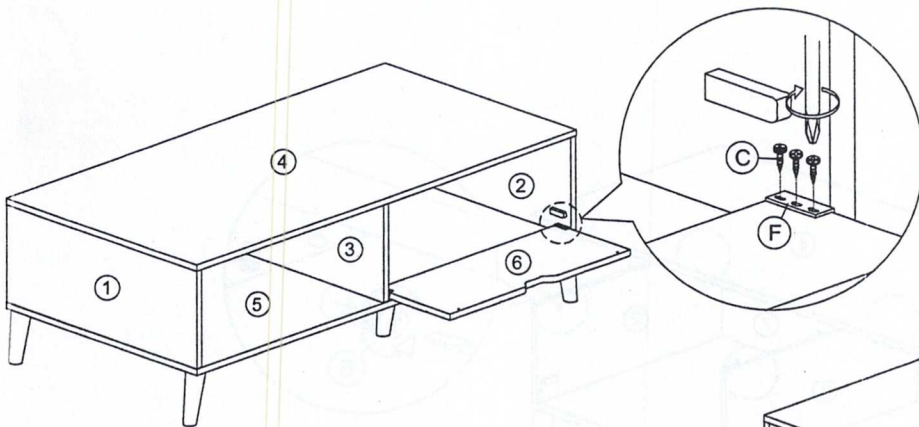

Assembly Instruction

Step 11

C		M3.5x16mm Screw	2Pcs
---	---	-----------------	------

E		2 Pin Magnet	2Pcs
---	---	--------------	------

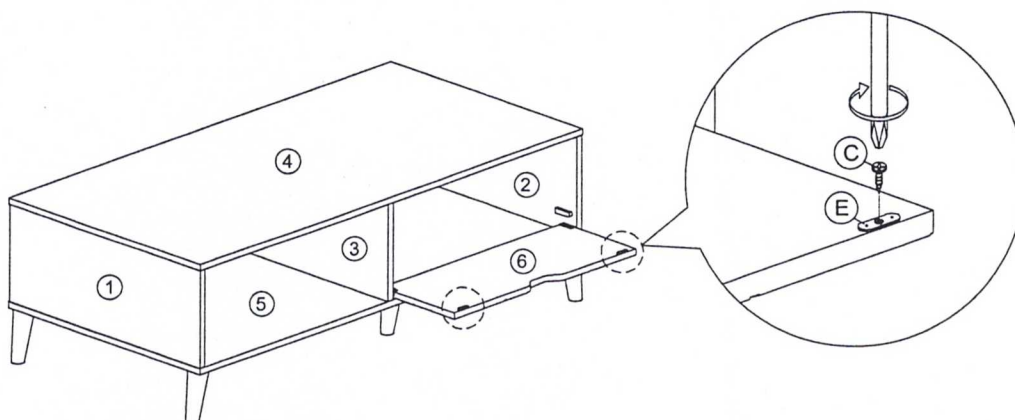

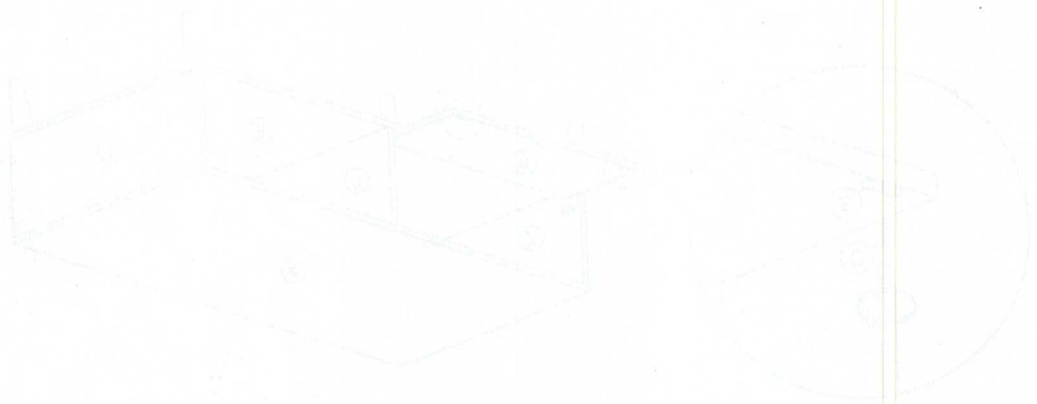

step 1	check instructions	no	assembly	step
--------	--------------------	----	----------	------

Assembly Instruction

