



Advanced Innovative Machinery

AIM PERFORMANCE PRODUCTS

Parts#MB001-003

•Reverse Gear MAMBA (Monoblock for Hydraulic operated)

For '13 and Later Big Twin Hydraulic Clutch Models

Installation Instructions

Read and become familiar with these installation instructions before start.

Monoblock for Hydraulic operated (Parts#MB001-003)

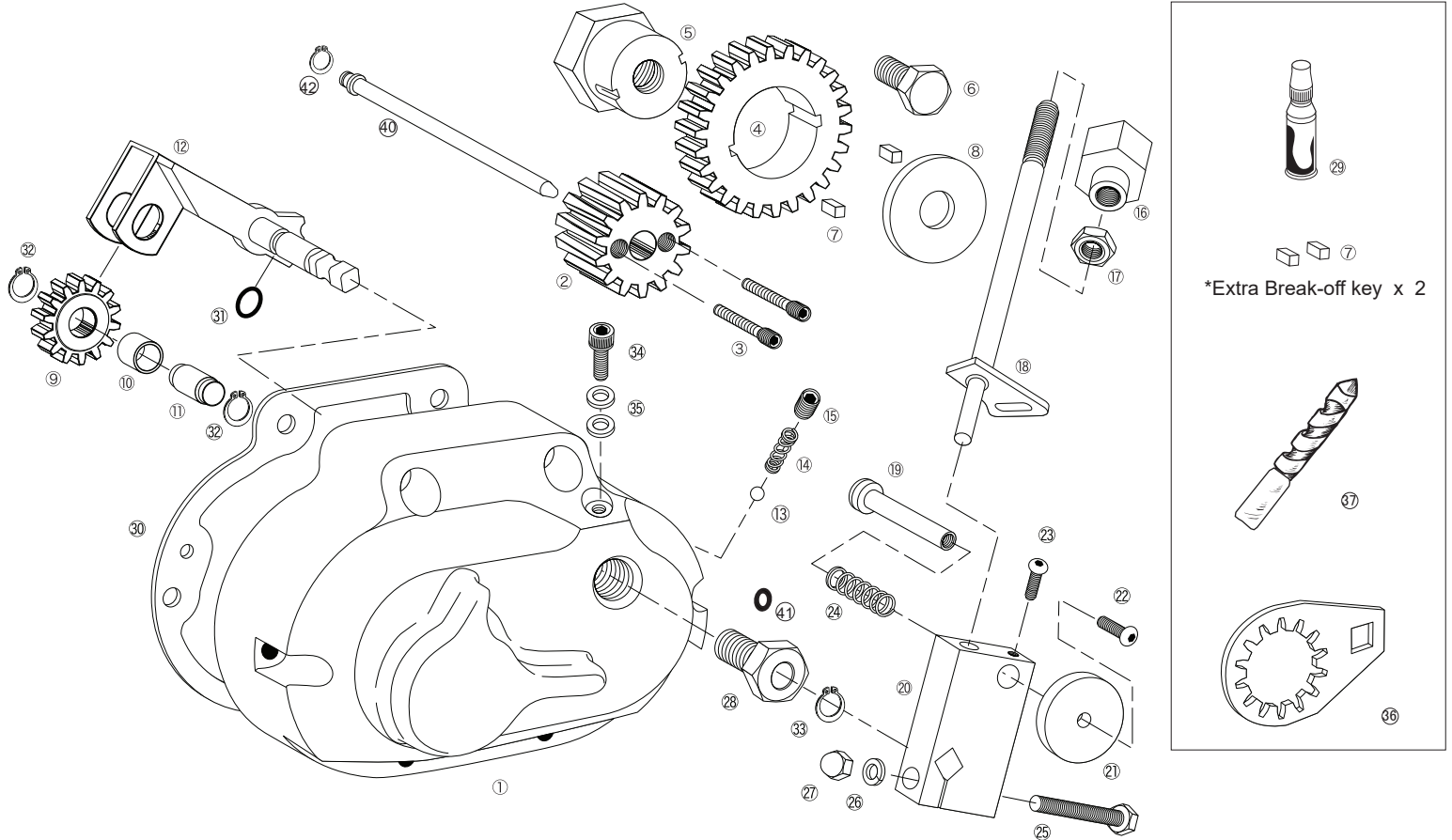

Parts#	Name	Q	
①	PMB001-102	Gear housing	1
②	PMB001-002	Main gear	1
③	PMB001-003	Lock pin screw	2
④	PMB001-004	Counter gear	1
⑤	PMB001-005	Counter nut	1
⑥	PMB001-006	Bolt M10x10	1
⑦	PMB001-007	Break-off key	4
⑧	PMB001-008	Washer 10mm x 32mm	1
⑨	PMB001-009	Idler gear	1
⑩	PMB001-010	Idler bushing	1
⑪	PMB001-011	Idler pin	1
⑫	PMB001-012	Reverse shifter	1
⑬	PMB001-013	Ball bearing 8mm	1
⑭	PMB001-014	Detent spring	1
⑮	PMB001-015	Detent set screw	1
⑯	PMB001-016	Shift knob	1
⑰	PMB001-017	Nut 10mm	1
⑱	PMB001-018	Shift lever	1
⑲	PMB001-019	Shift lock pin	1
⑳	PMB001-020	Shift body	1

Parts#	Name	Q	
㉑	PMB001-021	Shift disc	1
㉒	PMB001-022	Bolt M6x10	1
㉓	PMB001-023	Bolt M5x15	1
㉔	PMB001-024	Spring	1
㉕	PMB001-025	Bolt M8x45	1
㉖	PMB001-026	Spring washer M8	1
㉗	PMB001-027	Nut M8	1
㉘	PMB001-028	Shifter bush bolt	1
㉙	PMB001-029	LockTite #620(Green)	1
㉚	PMB001-030	Gasket	1
㉛	PMB001-031	O-ring	1
㉜	PMB001-032	Retaining ring	2
㉝	PMB001-033	Retaining ring(Stainless)	1
㉞	PMB001-034	Cap screw M6x10	1
㉟	PMB001-035	Washer	2
㊱	PMB001-089	Plate wrench	1
㊲	PMB001-078	5mm Drill Bit	1
㊳	PMB001-040	433 mm Clutch push rod	1
㊴	PMB001-041	O-ring	1
㊵	PMB001-042	Retaining ring	1



Advanced Innovational Machinery

AIM PERFORMANCE PRODUCTS

Parts#MB001-003

•Reverse Gear MAMBA (Monoblock for Hydraulic operated)

For '13 and Later Big Twin Hydraulic Clutch Models

Installation Instructions 1/3

Read and become familiar with these installation instructions before start.

⚠ WARNING!!

To prevent accidental vehicle start-up, which could cause serious injury, disconnect negative(-) battery cable before proceeding. Always wear proper eye protection to protect your eyes.

Note

Touring models: '09-'10 models are not required pipe modifications. Other years require the True dual pipe(Parts#MB004-003) or changing full exhaust system due to clearance issue.

Softail, Dyna models and some aftermarket exhaust pipes: May be required pipe modifications or changing exhaust pipe due to clearance issue.

1. Drain the transmission oil. Remove exhaust pipe if it is necessary.
2. Remove the Rightside transmission side cover and oil slinger assembly.
3. Remove two nuts from the mainshaft and countershaft.
4. Clean threads of mainshaft and countershaft using a parts cleaner to remove oil. Apply plenty of the supplied LockTite# 620 (Green) ⑳ to thread of mainshaft.

5. **Caution**
Do not use impact wrench (Power tool) to tighten the main gear ② which causes breaking mainshaft.

Note
 To prevent rotating mainshaft during tightening main gear. Shift into 1st gear and apply rear brake.

See **Figure 1**. Tighten the main gear ② to **80ft-lbs (109Nm)** using the supplied plate wrench ⑳ .

6. **Caution**
Use Regular Drill which is less than 3000rpm. Do not use high speed air grinder and push the supplied 5mm bur very hard which causes breaking the bur.

Caution
Do not grind more than 0.901" (23mm) depth which causes damaging bearing inner race and bur.

See **Figure 2**. Using the drill and supplied 5mm bur ㉑, drill the mainshaft straight (This is for Lock pin) to the depth of **0.901"(23mm)** from the main gear surface through two holes of the main gear.

7. Completely clean the drilled holes. Use care to ensure debris does not enter transmission.

8. See **Figure 3**. **Do not apply any LockTite to lock pin screw ㉓**. Install Lock pin screws into the main gear. Tighten the lock pin screw to **8 ft-lbs**.

9. See **Figure 4**. Clean thread of the counter nut ㉕ using parts cleaner to remove oil. Apply plenty of the supplied LockTite#620 (Green) ㉑ to thread of countershaft.

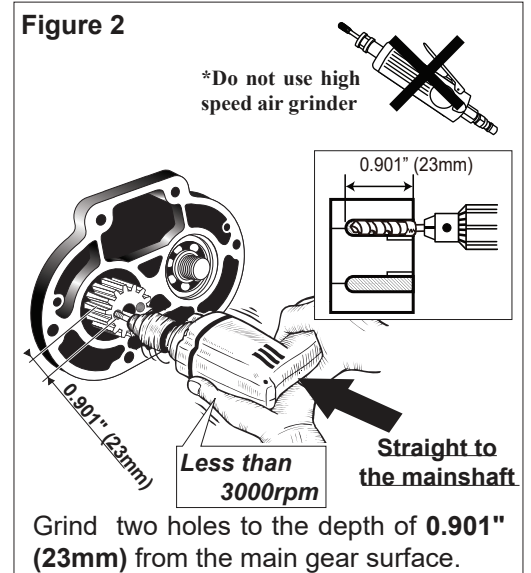
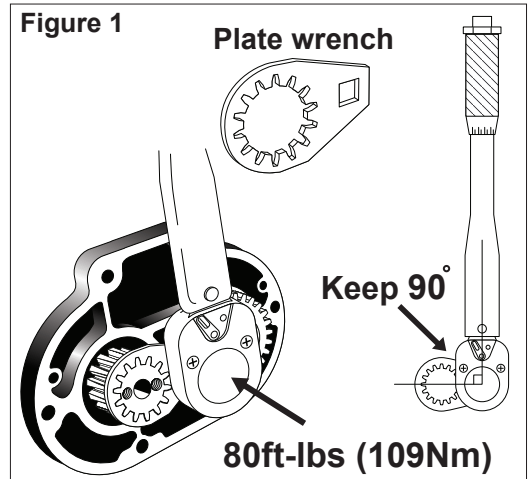



Advanced Innovative Machinery

AIM PERFORMANCE PRODUCTS

Parts#MB001-003

•Reverse Gear MAMBA (Monoblock for Hydraulic clutch operated)
For '13 and Later Big Twin Hydraulic Clutch Models

Installation Instructions 2/3

10. *Caution*
Do not use impact wrench (Power tool) to tighten the counter nut which causes breaking countershaft.

Note

To prevent rotating countershaft during tightening main gear. Shift into 1st gear and apply rear brake.

Tighten the counter nut ⑤ to **80ft-lbs (109Nm)** using the 32mm socket.

11. Apply grease between the counter nut and counter gear. Install the counter gear ④ on to the counter nut.

12. See Figure 5. Align key grooves on the counter nut and counter gear. Install two break-off keys ⑦ into the grooves.

13. *Note*
To prevent rotating countershaft during tightening main gear. Shift into 1st gear and apply rear brake.

See Figure 6. Apply LockTite#271 (Red) to the thread of bolt ⑥. Install bolt with the washer to the counter nut. Tighten the bolt ⑥ to **56ft-lbs (75Nm)**.

Figure 3

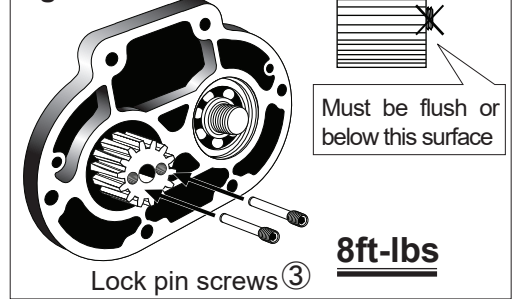

Figure 4

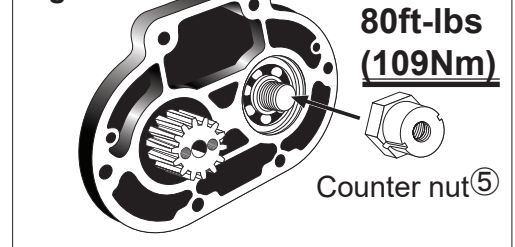

Figure 5

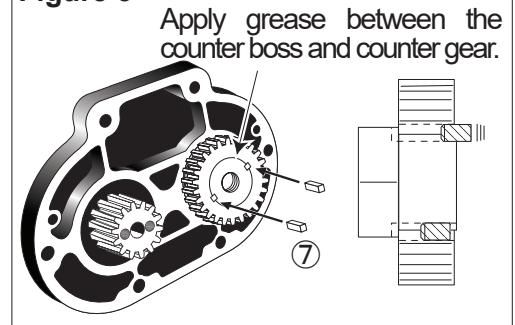
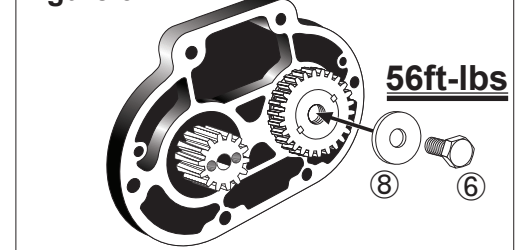

Figure 6





Advanced Innovational Machinery

AIM PERFORMANCE PRODUCTS

Parts#MB001-003

*Reverse Gear MAMBA (Monoblock for Hydraulic clutch operated)

For '13 and Later Big Twin Hydraulic Clutch Models

Installation Instructions 3/3

14. Remove Hydraulic piston from the stock side cover.

15. **Caution**

Be sure to install oil seals correctly. Do not pinch oil seals.

See Figure 7. Check oil seals are correctly seated piston grooves. Apply silicon grease slightly to both Hydraulic piston and bore. Install Hydraulic piston to Reverse gear housing.

16. **Caution**

Be sure to get Hydraulic clutch line into the thread of Reverse gear housing correctly by hand untill hand tight.

See Figure 8. Install the O-ring (41) in the kit. **Start with hand only** untill hand tight to connect hydraulic clutch line then use tool to tighten it in order to avoid cross threaded.

17. Install the side cover gasket and Reverse gear housing using stock bolts. Tighten the bolts to **9ft-lbs (12Nm)**.

18. Remove the derby cover. Remove clutch push rod retainer plate assembly.

20. **See Figure 9.** Remove retaining ring and clutch push rod from retainer plate.

21. Install clutch push rod (40) in the kit to retainer plate. Install Retaining ring (42) in the kit to push rod.

22. Install clutch push rod retainer plate assembly to clutch. Install retainer plate retaining ring.

23. Install derby cover.

24. Breed clutch fluid line. See Harley-Davidson service manual.

25. Fill the transmission with transmission lubricant. See Harley-Davidson service manual.

26. Install the exhaust pipe if it is necessary.

27. Connect the battery.

Figure 7

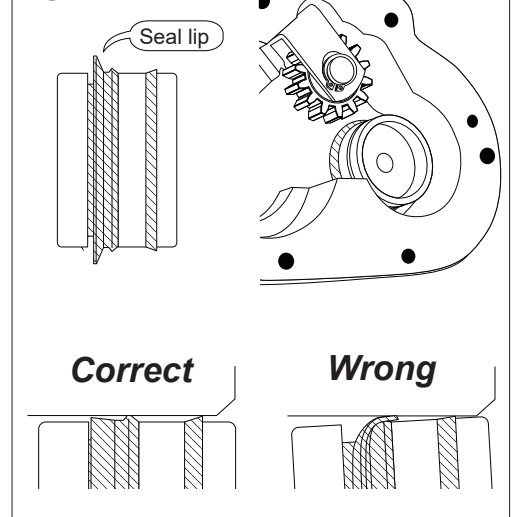

Figure 8

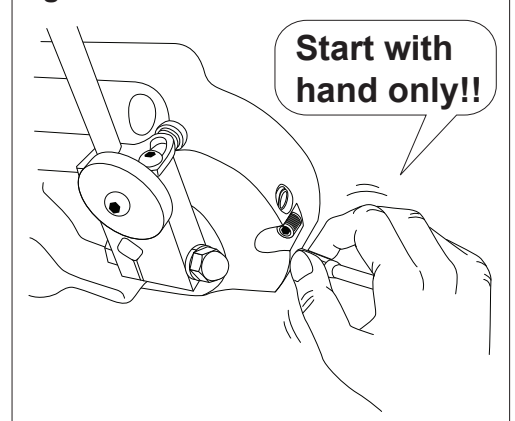
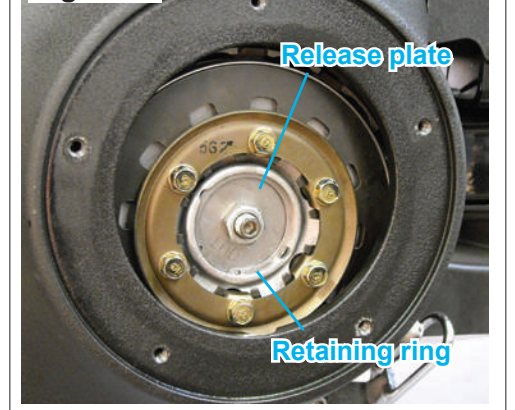

Figure 9



Warranty

One year warranty on Reverse Gear parts only.

Reverse gear operation

To engage reverse gear:

⚠ WARNING

- *Do not shift into the reverse gear before shift into 1st gear to stop spinning all gears in the transmission.*
- *Use reverse gear in Neutral. Transmission must be in Neutral when engaging or using reverse gear.*
- *Reverse gear is intended for light duty use only.*

Failure to do so may result in breaking brake-off keys, damaged transmission or serious injury.

Note

No throttle, just release (engine idle speed) the clutch lever until you are accustomed with motorcycle going reverse.



Disengage the clutch. Shift into the first gear to stop spinning all gears in the transmission to prevent damaged transmission when put into the reverse gear.

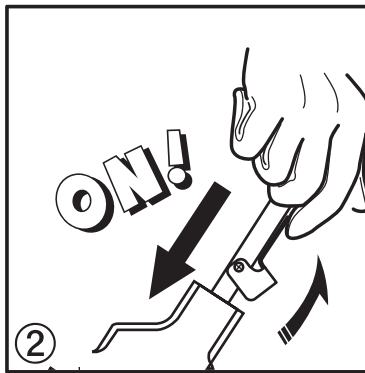

Pull the safety trigger and push the shift lever down to shift into reverse gear. **Do not engage the clutch at this time.**

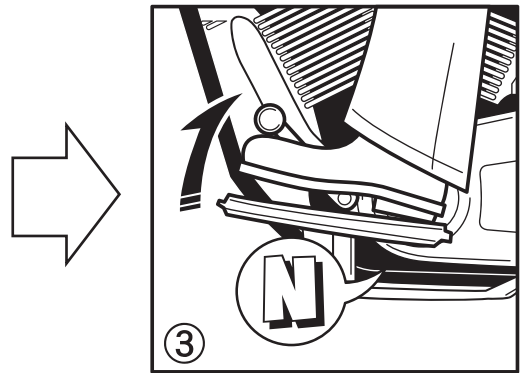

Shift transmission in Neutral. Engage the clutch to reverse motorcycle.

To disengage reverse gear:

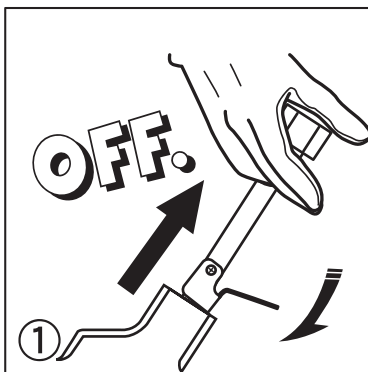

⚠ WARNING

Disengage the reverse gear before engaging any forward gears. Failure to do so may result in breaking brake-off keys, damaged transmission or serious injury.

Lift the shift lever up to disengage the reverse gear.



Advanced Innovative Machinery

AIM PERFORMANCE PRODUCTS

Supplement

•Reverse Gear MAMBA (All models)

Read and become familiar with these installation instructions before start.

Break-off key replacement

There are two break-off keys between the counter nut and gear. These keys will break when excessive load was applied to save more expensive gears than break-off keys.

There are two of extra keys in the kit. If you break all keys in the kit. Please purchase new Break-off keys (Parts#PMB001-007).

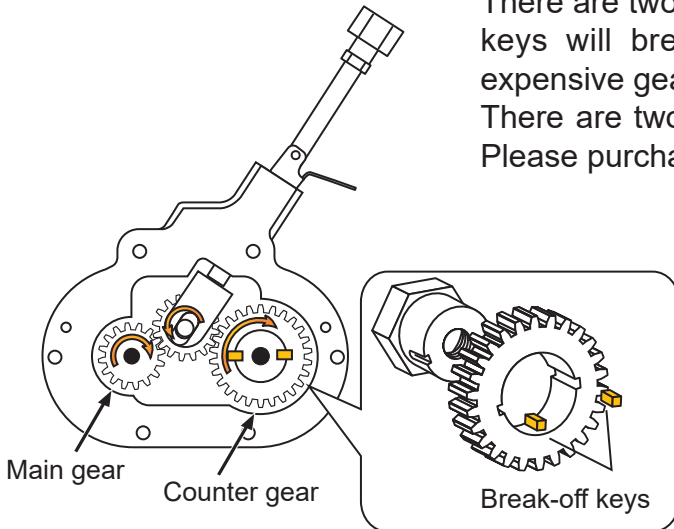

Excessive load!!

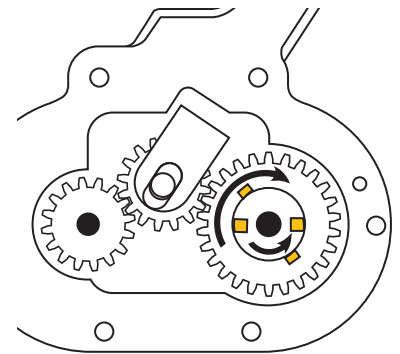

True Dual Pipe

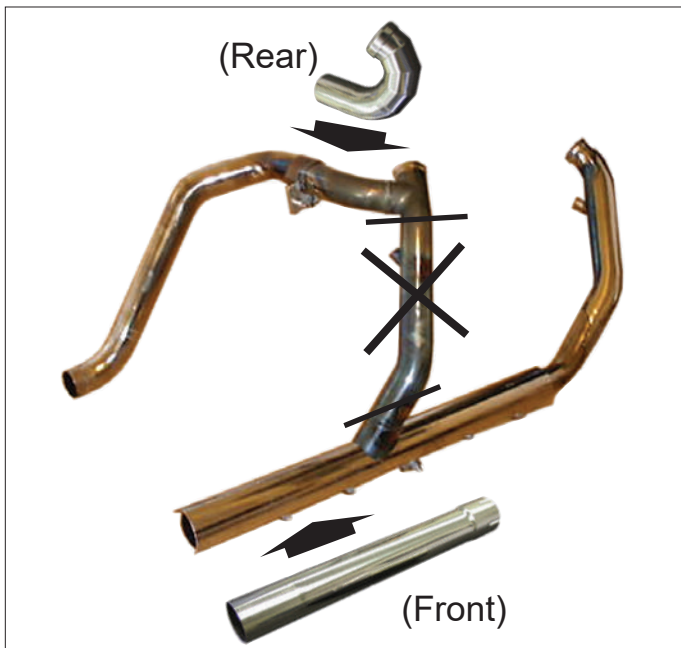

True Dual Pipe

For '87-'08 Touring model's stock exhaust pipe

- Eliminate cross over pipe to clear our Reverse gear kit for Touring models
- O2 sensor fitting for '07-'08 models
- Kit comes with O2 sensor plug for '87-'06 models

Parts# FS001-001 \$225.00



Advanced Innovative Machinery

AIM Corp.

16631 Gemini Lane
Huntington Beach, CA 92647

Phone: 714-848-3030 Fax: 714-848-3031

E-mail: info@aim-tamachi.com

www.aim-tamachi.com