

---

# REXGEAR

*Your Power Solution Expert*

## 87400 High Accuracy Compact 4-Channel Power Analyzer User Manual

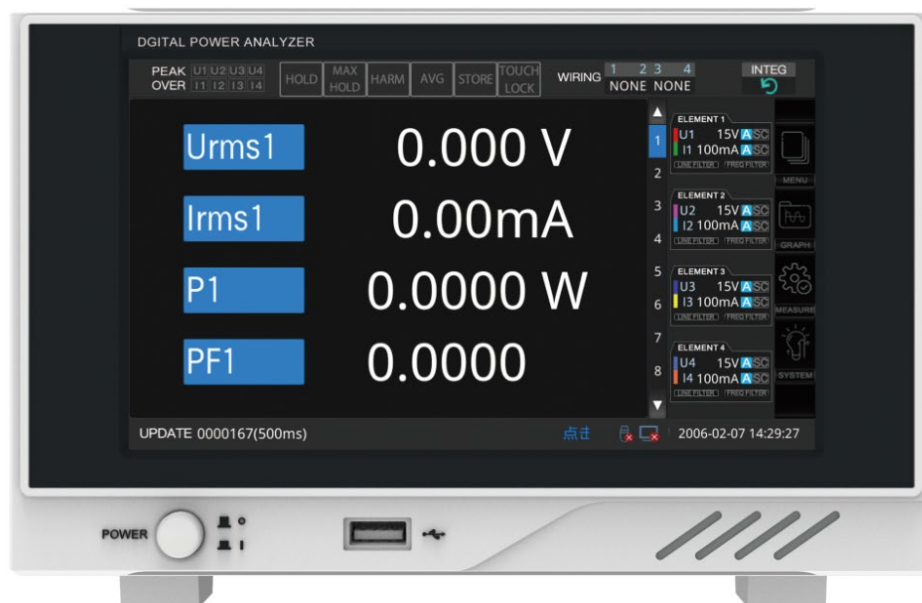

**REXGEAR Inc.**

---



## Table of Contents

Table of Contents.....	1
Section 1 Safety Rules .....	1
Section 2 Technical Specifications.....	2
I. Product Introduction .....	2
II. Features .....	2
III. Main technical parameters of equipment.....	2
VI. System Setting Influence on Accuracy .....	3
V. Dimensions W×H×D .....	4
Section 3 Operation Manual.....	5
I. Front Panel.....	5
II. Rear Panel.....	7
III. Electrical wiring description.....	8
Section 4 Operation.....	11
I. Functional Description .....	11
II. Setting display items .....	12
III. Set basic measurement conditions.....	16
VI. INTEG function .....	24
V. HARM.....	25
VI. Waveform display .....	27
VII. STORE .....	29
VIII. Communication settings.....	30
IX Master settings .....	31
X. Operation Manual .....	31
Section 5 External Interfaces.....	32
I. RS-232/485 port .....	32
II. Ethernet communication interface .....	33
Section 6 Appendix to Protocol .....	34
I. Modbus RTU protocol.....	34
II. ModbusTCP protocol.....	42
Section 7 Maintenance .....	51
I. Maintenance and Care .....	51
II. Troubleshooting.....	51

---



---

## Section 1 Safety Rules

Read this manual carefully before operation of 87400 High Precision Compact 4-Channel Power Analyzer and corresponding types, and follow the manual strictly!



Warning! prompting that the operation, application or conditions are dangerous, or even cause personnel death/injury. This sign shall be attached on the “Warning” positions listed in the manual.



Caution! prompting that the operation, application or conditions are dangerous or even damage to the analyzer, or the data stored in the instrument is lost. This sign shall be attached on the necessary positions noting “Caution” as listed in the manual.

- This manual will be changed following upgrading of performance and functions without prior notice.
- The pictures in this manual may differ from what appears on the screen of the instrument due to upgrading etc.
- We try our best ensure the accuracy of the contents of this manual. For any questions or errors, please contact REXGEAR company
- Without the permission of REXGEAR, it is strictly prohibited to copy or reproduce whole or part of the contents of this manual.
- To consult or ask for the latest manual, refer to the mailbox on homepage.

## Section 2 Technical Specifications

### I. Product Introduction

This 87400 series High Precision Compact 4-channel power analyzer adopts the latest FPGA+ARM parallel synchronous processing technology, IEC standard 3U compact chassis with exquisite appearance, widely used in energy efficiency testing etc. of three-phase electrical equipment, standard Ethernet-based TCP-MODBUS protocol, in line with engineering integration; LCD display, touch experience, waveform display of up to 4 channels simultaneously, CSV data export, effective Edit Range and other advanced functions.

### II. Features

1. High precision, wide frequency band: basic precision up to 0.05%, the minimum 100ms display data update cycle, AC/DC signal, power test bandwidth DC 0.5HZ-100kHz, meeting the requirements of various standard and non-standard sine wave load power tests.
2. Advanced motor measurement module and reserved motor sensor measurement interface, suitable for most motor sensor signal tests on the market; three-phase motor efficiency tested by a single machine to ensure signal synchronization and improve accuracy.
3. RS232/RS485, Ethernet interface; standard modbus, modbus/TCP and other optional protocols.
4. Mixed-frequency sampling, more accurate measurement of high frequency waveform.
5. LCD display, touch screen operation, simultaneous display of multiple waveforms.

### III. Main technical parameters of equipment

Model	87400
Current specification	20A
Wiring	1P3W (single-phase 3-wire), 3P3W (three-phase 3-wire, 2-voltage and 2-current), 3V3A (three-phase 3-wire, 3-voltage and 3-current), 3P4W (three-phase 4-wire)
Input impedance of each phase	Voltage: about 2M $\Omega$ Direct current input: about 10m $\Omega$ Current sensor input: about 100k $\Omega$
Full-scale crest factor	3 or 6
Rated voltage range (Direct input)	15/30/60/100/150/300/600/1000*[V] * Crest factor of 1000V full-scale is 1.5
Rated current range (Direct input)	20A Current specification: 100m/200m/500m/1/2/5/10/20*[A] Optional: 50A Current specification: 500m/1/2/5/10/20/40/50*[A] 1A Current specification: 5m/10m/20m/50m/100m/200m/500m/1*[A] * Crest factor of 20A maximum scale full- scale is 1.5
Rated current range (Sensor input)	50m/100m/200m/500m/1/2/5/10[V]
Voltage/Current Precision scope	(1% ~ 110%) $\times$ Range * Accuracy of 1000V/20A range: (1% ~ 100%) $\times$ scale
Range of power factor	$\pm(0.001 \sim 1.000)$
Voltage measurement accuracy	DC $\pm(0.05\% \times \text{indication} + 0.05\% \times \text{range})$ 0.1Hz $\leq f < 66$ Hz $\pm(0.05\% \times \text{indication} + 0.05\% \times \text{range})$ 66Hz $< f \leq 1$ kHz $\pm(0.1\% \times \text{indication} + 0.1\% \times \text{range})$ 1kHz $< f \leq 10$ kHz $\pm(\{0.1+0.05 \times (f-1)\} \% \times \text{indication} + 0.2\% \times \text{range})$ 10kHz $< f \leq 100$ kHz $\pm(\{0.5+0.04 \times (f-10)\} \% \times \text{indication} + 0.3\% \times \text{range})$
Current precision	DC $\pm(0.05\% \times \text{indication} + 0.05\% \times \text{range})$ 0.1Hz $\leq f < 66$ Hz $\pm(0.05\% \times \text{indication} + 0.05\% \times \text{range})$ 66Hz $< f \leq 1$ kHz $\pm(0.1\% \times \text{indication} + 0.1\% \times \text{range})$ 1kHz $< f \leq 10$ kHz $\pm(\{0.1 \times f\} \% \times \text{indication} + 0.2\% \times \text{range})$ 10kHz $< f \leq 100$ kHz $\pm(\{1+0.08 \times (f-10)\} \% \times \text{indication} + 0.3\% \times \text{range})$

## Section 2 Technical Specifications

Active power measurement accuracy	DC	$\pm (0.05\% \times \text{indication} + 0.05\% \times \text{range})$
	$0.5\text{Hz} \leq f < 45\text{Hz}$	$\pm (0.1\% \times \text{indication} + 0.1\% \times \text{range})$
	$45\text{Hz} \leq f < 66\text{Hz}$	$\pm (0.05\% \times \text{indication} + 0.05\% \times \text{range})$
	$66\text{Hz} < f \leq 1\text{kHz}$	$\pm (\{0.2 + 0.1 \times (f - 1)\} \% \times \text{indication} + 0.2\% \times \text{range})$
	$1\text{kHz} < f \leq 10\text{kHz}$	$\pm (\{0.2 + 0.1 \times (f - 1)\} \% \times \text{indication} + 0.3\% \times \text{range})$
	$10\text{kHz} < f \leq 100\text{kHz}$	$\pm (\{5.1 + 0.18 \times (f - 50)\} \% \times \text{indication} + 0.3\% \times \text{range})$
Active power measurement range	4.4mW~4.4 kW/phase @220V, PF=0.001~1.000	
Active power resolution	0.1mW	
Frequency range	DC, 0.5Hz ~ 100kHz	
Frequency measurement accuracy	$\pm 0.1\% \times \text{indication}$	
Harmonic measurement	10Hz ~ 600Hz, 1~100th harmonic content, total distortion	
Energy measurement range	0~99999MWh (Resolution: 1mWh/0.01mAh)	
Energy measurement accuracy	$\pm 0.2\% \times \text{indication}$	
Power meter	99 hours 59 minutes 59 seconds	
Filter	500Hz, 5.5kHz voltage/current line and frequency filter	
Voltage/current ratio	1.0 ~ 50000.0	
External input ratio	0.010~100.000	
Update cycle	100m / 200m / 500m / 1/2/5/10[s]	
Control interface	Standard RS-232, Ethernet; Optional RS-485, motor measurement board (pulse torque rotation rate sensor)	
Protocol	REXGEAR3.0, Modbus, TCP Modbus	
Outline dimension	215 (W) × 133 (H) × 374 (D) mm	
Size of opening	215 (W) × 133 (H) mm	
Foot height	15 mm	
Machine weight	About 4 kg	
Power consumption of whole machine	About 60VA	

1. Temp.: 23±5°C; Humidity: 30%~75%RH; input wave: sine; common mode; voltage: 0V; LINE filter: OFF; frequency filter: ON under 440Hz; power factor λ: 1; crest factor: 3. After warming up. Connected, after resetting or changing the scale

2. The f in the measurement accuracy formula is the frequency in kHz.

3. When the update rate is 100ms, all accuracies are the value plus 0.05% of the reading.

4. Impact due to change to Temp. after resetting or changing the scale:

Plus 0.02% x scale/°C for voltage DC accuracy, 500μA/°C for current DC accuracy, 50μV/°C for external sensor DC accuracy, product of voltage impact and current impact for power DC accuracy.

## VI. System Setting Influence on Accuracy

### 1. Line filter influence on measurement accuracy

The LINE filters are in the voltage/current measurement circuit. As the LINE filter is switched on, the measurement doesn't contain high frequency components, and the noise in the frequency converter, switching power supply or wave distortion will be eliminated, directly influencing the voltage, current and power measurement accuracy. As the LINE filter is switched on, the influence on measurement accuracy is as followed:

Line filter	Voltage/Current	Power
-------------	-----------------	-------

## Section 2 Technical Specifications

ON	For cutoff frequency of 500Hz, 45Hz~66Hz: plus 0.2% x reading <45Hz: plus 0.5% x reading For cutoff frequency of 5.5kHz, ≤66Hz: plus 0.2% x reading 66Hz~500Hz: plus 0.5% x reading	For cutoff frequency of 500Hz, 45Hz~66Hz: plus 0.3% x reading <45Hz: plus 1% x reading For cutoff frequency of 5.5kHz, ≤66Hz: plus 0.4% x reading 66Hz~500Hz: plus 1.2% x reading
----	--	--

### 2. Harmonics influence on measurement accuracy

As harmonics measurement is ON, the measurement accuracy (reading error +scale error) is as following:

(1) As the LINE filter is ON (5.5kHz)

Frequency	Voltage/Current	Power
10Hz≤f<45Hz	0.4% x reading +0.35% x scale	0.85% x reading +0.5% x scale
45Hz≤f<440Hz	0.75% x reading +0.35% x scale	1.5% x reading +0.5% x scale
440Hz≤f<1kHz	1.2% x reading +0.35% x scale	2.4% x reading +0.5% x scale

(2) As the LINE filter is OFF

Frequency	Voltage/Current	Power
10Hz≤f<45Hz	0.15% x reading +0.35% x scale	0.35% x reading +0.5% x scale
45Hz≤f<440Hz	0.15% x reading +0.35% x scale	0.25% x reading +0.5% x scale
440Hz≤f<1kHz	0.2% x reading +0.35% x scale	0.4% x reading +0.5% x scale

### 3. Calculation cycle and frequency measurement lower limit

The frequency measurement range is different for different calculation cycle, as shown following:

Calculation cycle	0.1s	0.25s	0.5s
Measurement frequency range	25Hz~100kHz	10Hz~100kHz	5Hz~100kHz
	1s	2s	5s
	2.5Hz~100kHz	1.5Hz~50kHz	0.5Hz~20kHz

### V. Dimensions W×H×D

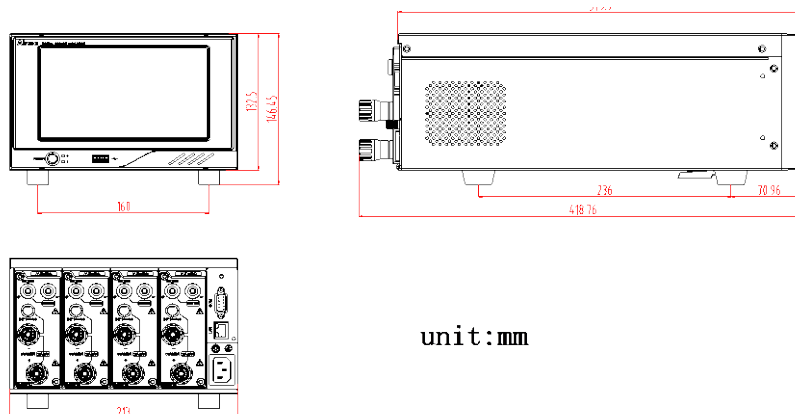

Figure 2-1 Outline dimension



## Section 3 Operation Manual

### I. Front Panel

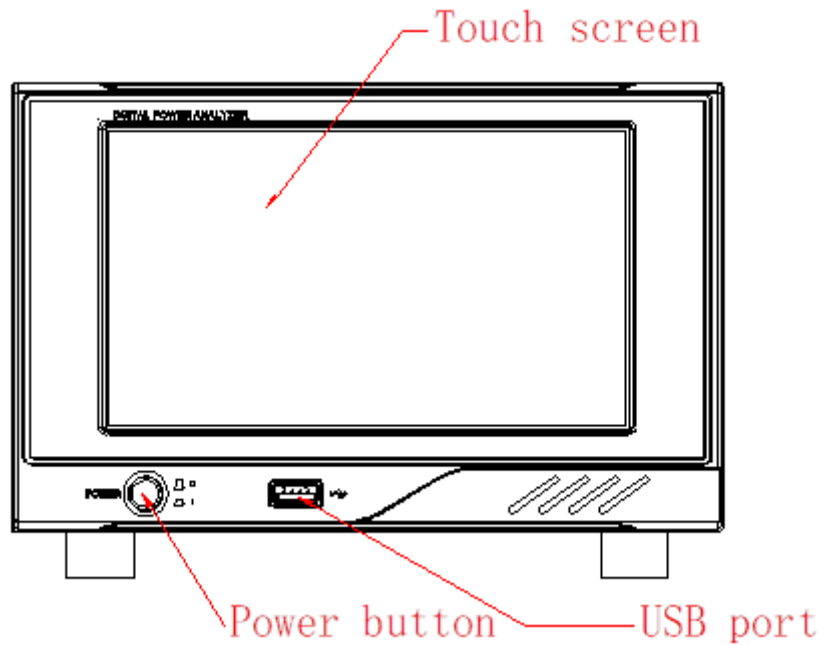

Figure 3-1 Front panel

### 1. Test Interface Description

- Main interface

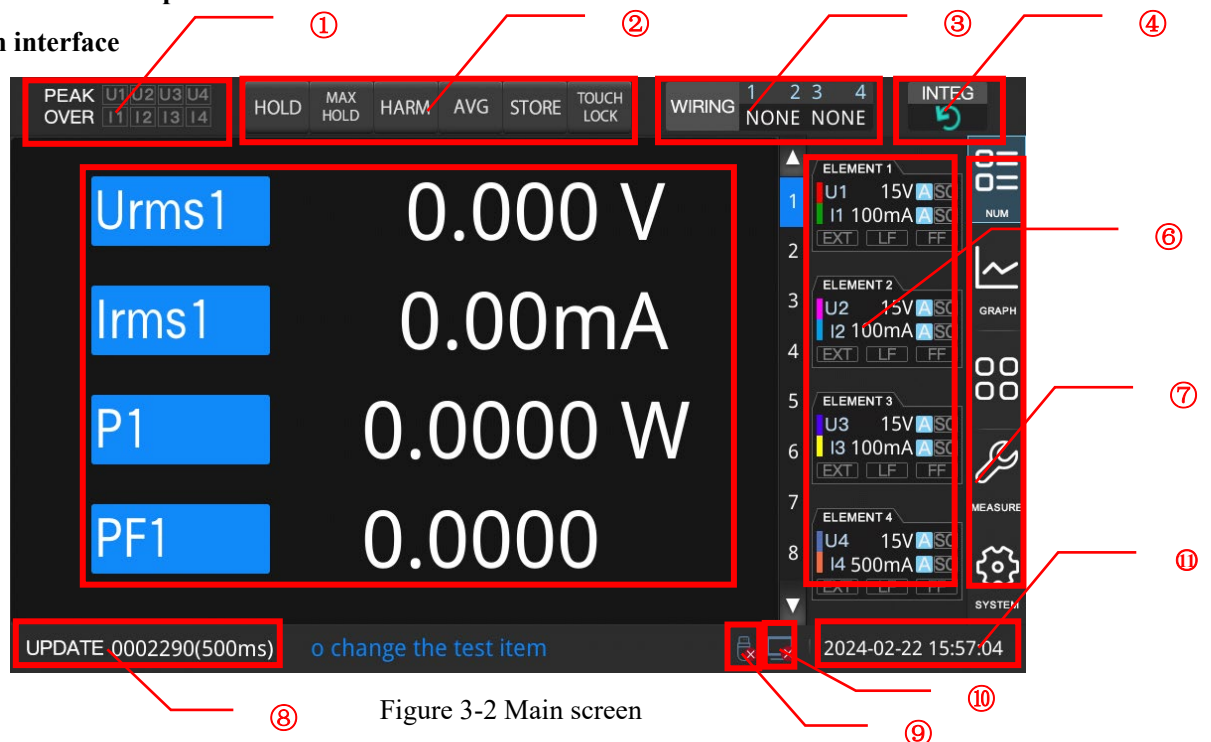

Figure 3-2 Main screen

- ① OVER RANGE LED
- ② Function LED
- ③ WIRING
- ④ INTEG LED

- ⑤ Data display
- ⑥ ELEMENT area: including range, waveform color, scale, and filter ON/OFF state.
- ⑦ Button function area.
- ⑧ Data update: real-time display of current data collection times of each input element after the measurement is started.
- ⑨ U-disk plug/unplug LED
- ⑩ Communication connection indication
- ⑪ Current time
- **Numerical screen:**

For numerical data display, multiple measurements can be displayed, including 4, 8, 16 or All (all displayed) optional; in addition, each displayed item can be set separately, convenient for quick view of various parameters and improving measurement efficiency, as shown in the figure below:

Numerical display:

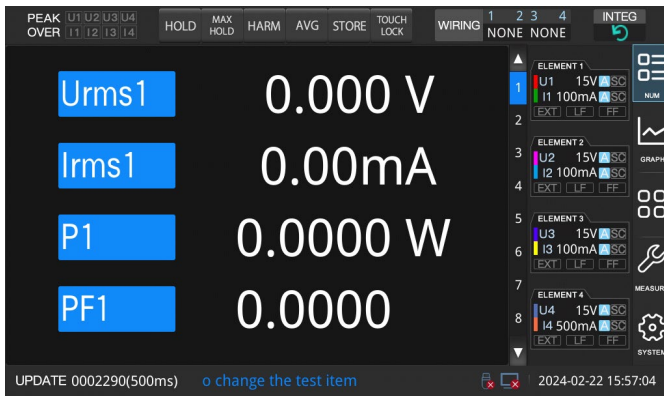

Figure 3-3 4-item display

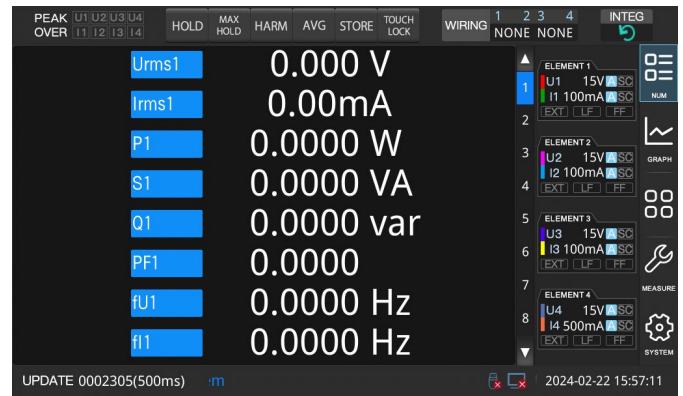

Figure 3-4 8-item display

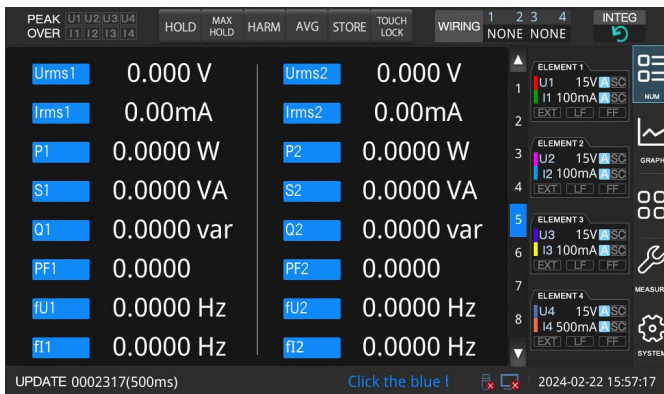

Figure 3-5 16-item display

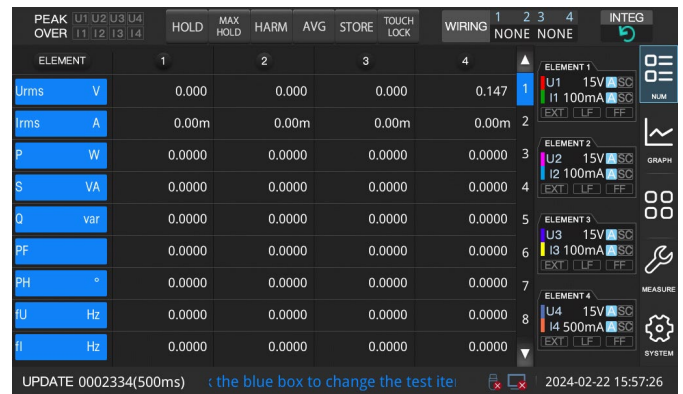

Figure 3-6 All value display

- **List (harmonic measurements)**

The harmonic module performs fast Fourier transform (DFT) processing on the original sampled points, and displays the voltage/current harmonic distortion, single harmonic content (up to 100th), single harmonic RMS and other parameters.

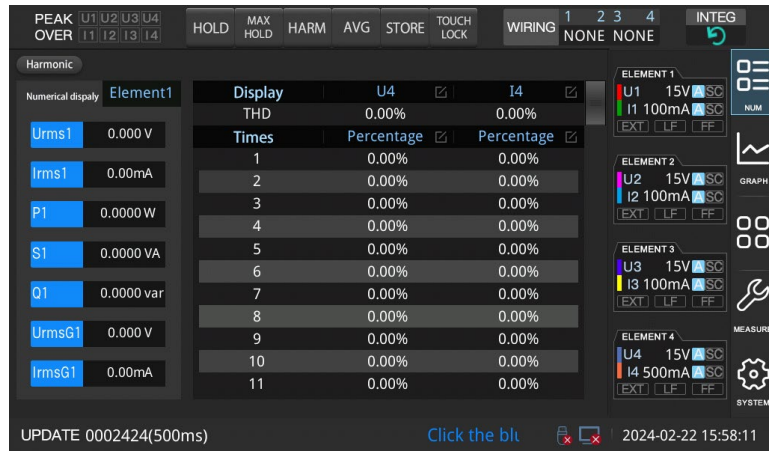

Figure 3-7 List

- **Waveform display**

To measure the waveform of voltage, current and other signals, view and analyze the voltage-current signal phase difference and waveform distortion. Multiple waveforms can be compared in the same group, and up to 4 waveforms can be displayed simultaneously.



Figure 3-8 Waveform Display

Note: The setting of related screen is described in Section 4 Operation.

## II. Rear Panel

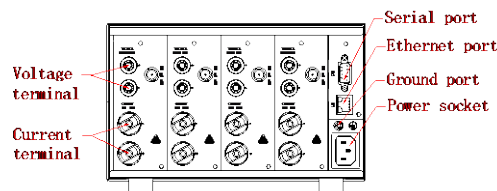

Figure 3-9 Rear panel

1. The rear panel consists of the following parts: power socket, voltage/current terminal, serial port, Ethernet port.

2. The power socket is set for the power input for the instrument.
3. The voltage/current terminal is the terminal for connecting the measurement circuit.
4. The serial port is standard RS232 or optional RS232/RS485.
5. The network port is RJ-45.

## III. Electrical wiring description

### 1. Voltage input terminal

The terminal is a  $\Phi 4\text{mm}$  safety banana jack.

Insert the safety plug (wire not exposed) into the voltage input terminal. A voltage measurement line with a safety plug and a measurement clip is accompanied.

### 2. Current input terminal

M8 stud terminal is used. It is recommended to use professional OT crimping terminals to pre-treat the measurement wire. Buckle the OT terminal to the stud, and then hold the terminal knob to tighten. No current measurement wire is provided with the box.

### 3. Configuration and wiring

The wiring of analyzer depends on the configuration of the measurement channel, including 1P3W, 3P3W, 3V3A, 3P4W, etc.

#### 3.1 Single-phase 3-wire (1P3W) wiring

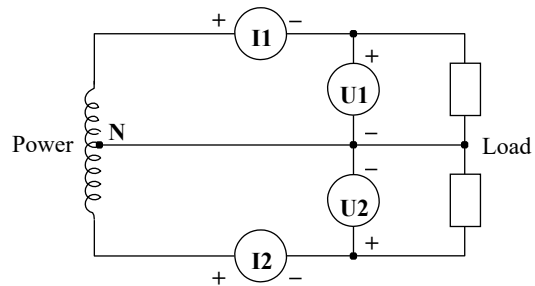
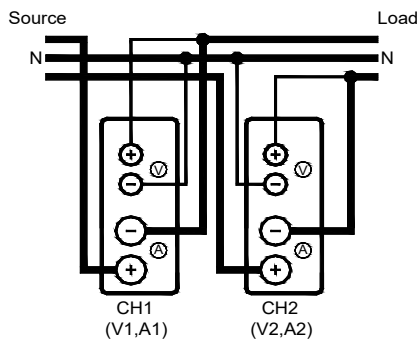

#### 3.2 Three-phase 3-wire (3P3W) wiring

##### 2 meters (2V2A) wiring

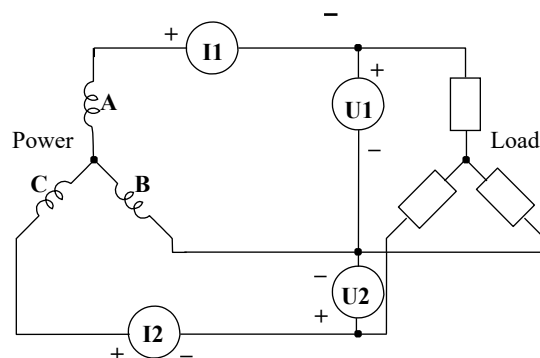
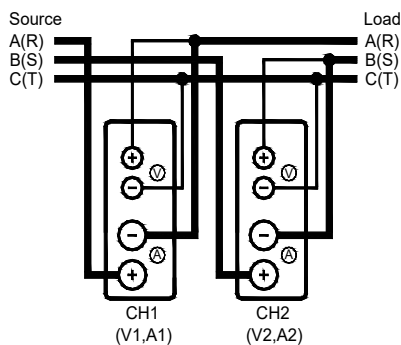

### 3.3 3 meters (3V3A) wiring

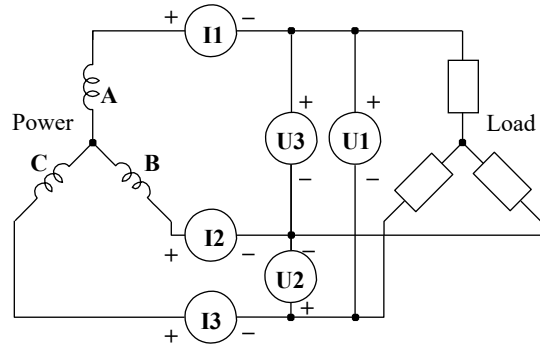
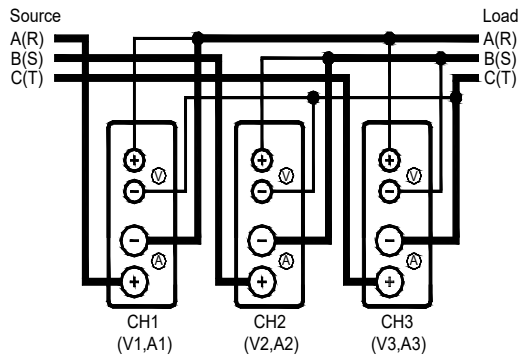

### 3.4 Three-phase 4-wire (3P4W) wiring

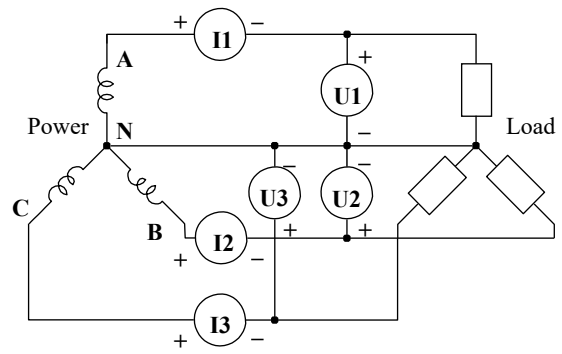
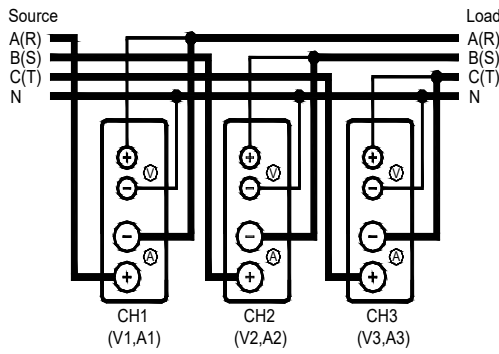

### 4. Wiring for verification using standard source

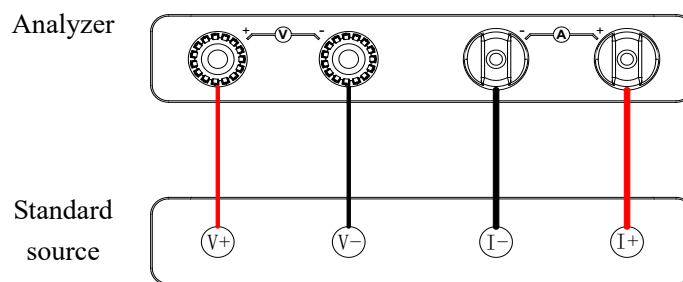

Figure 3-10 Wiring for verification using standard source

## 5. Wiring for verification using standard meter

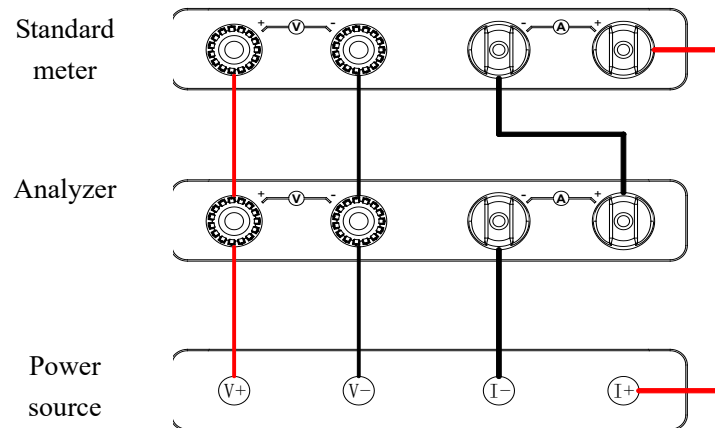

Figure 3-11 Wiring for verification using standard meter



- Press SHIFT+ESC before measuring to restore the initial settings (INIT).
- To perform current measurement, the voltage input terminal of the analyzer must have a voltage input of 60V or higher

## 6. Section of Cable

For carrying capacity of copper cable, see standard IEC 60364-5-523 IEC Electrical Installations of Buildings Part 5: Selection and Erection of Electrical Equipment - Section 523: Current-Carrying Capacities in Wiring Systems (1983). The maximum current measurement of the analyzer is 20A, it is recommended to use copper wires with section area  $\geq 4\text{mm}^2$ .

### Section 4 Operation

#### I. Functional Description

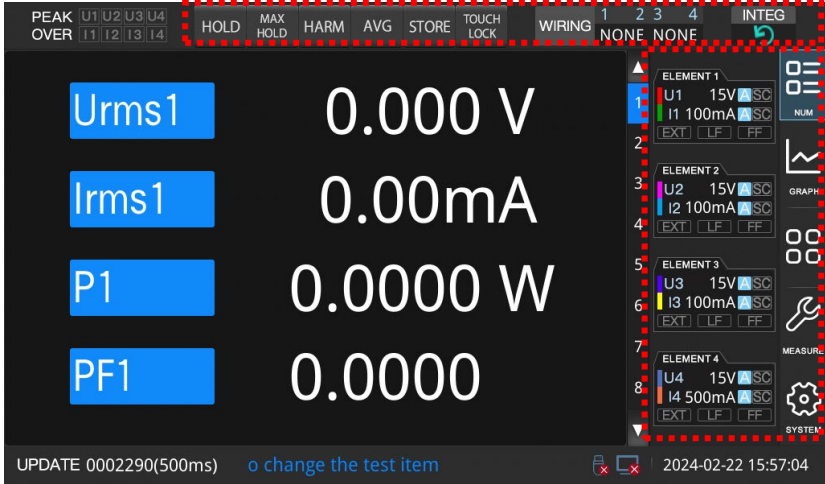

Figure 4.1 Fuctional Area

##### 1. General

The Fuctional Area is shown in the dashed frame in Figure 4.1, including range and page control, etc.

##### 2. Range area



Figure 4.2 Range area

Press the buttons in the range setting area (Figure 4.2) to control the voltage/current ranges. The steps are as follows:

- (1) Click on the channel area interface to pop up a voltage and current range selection menu ;
- (2) Adjust up/down ranges and auto range in RANGE area;
- (3) After setting up, the corresponding channel display area will change .

##### 3. PAGE area



NUM: Press it to switch to the numerical display screen. Press it again to switch the numerical screen.

GRAPH: Press it to switch to Waveform Display screen.

Middle button: Menu button, press to pop up menu options

MEASURE: Open the test settings interface

SYSTEM: Open the system settings interface

Figure 4.3 PAGE area

## 4. Function operation area



Figure 4.4 Function operation area

HOLD: Enable/disable hold function.

MAX HOLD: Used to turn on and off the maximum hold function.

HARM: Press it to enable harmonic analysis. Note that either harmonic source 1 or 2 must be enabled, otherwise the harmonic measurement cannot be turned on.

AVG: Used to turn on and off the averaging function.

STORE: Start/stop data storage.

INTEG: After pressing, the integration operation interface will pop up.

## II. Setting display items

### 1. Setting Mode Description



## Section 4 Operation

In numerical display screen, the items on the current page can be customized and will not be lost after power off, convenient to set multiple groups for targeted data view. The setting is as follows:

- ① Press the measurement item button, as shown in the dashed frame

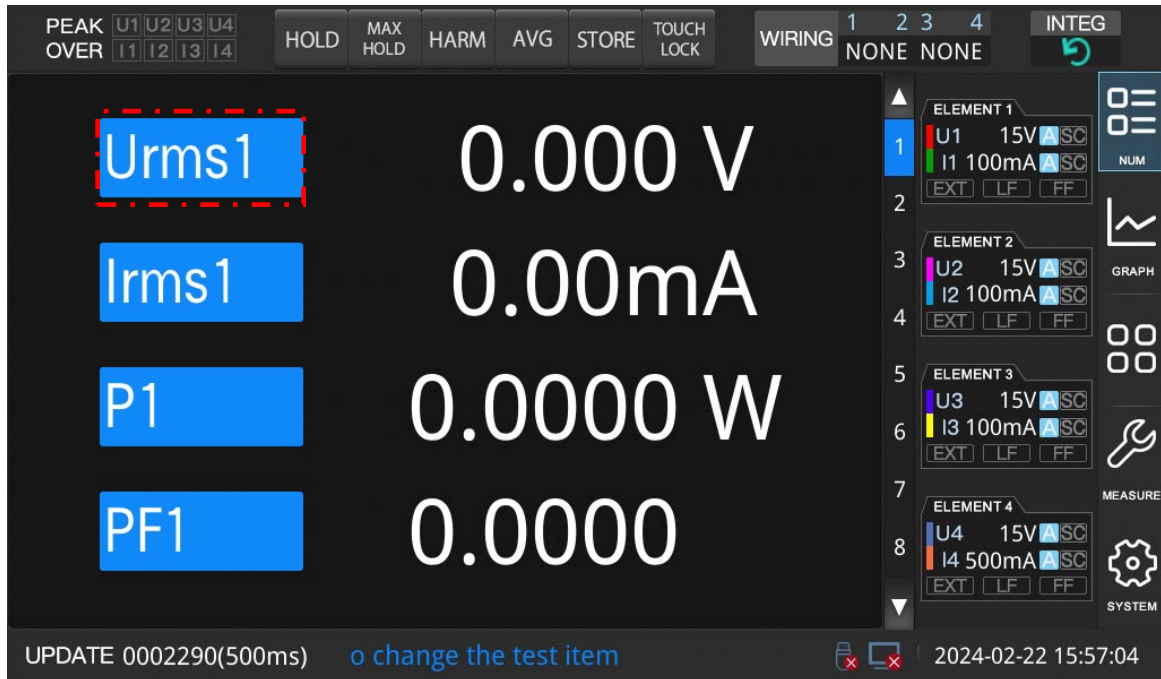

Figure 4.7 4-item display (before item change)

- ② The item selection box pops up. Select the measurement item and its channel to be displayed as shown in the figure below. Click OK to complete the setting. Click Cancel to exit the editing screen without saving.

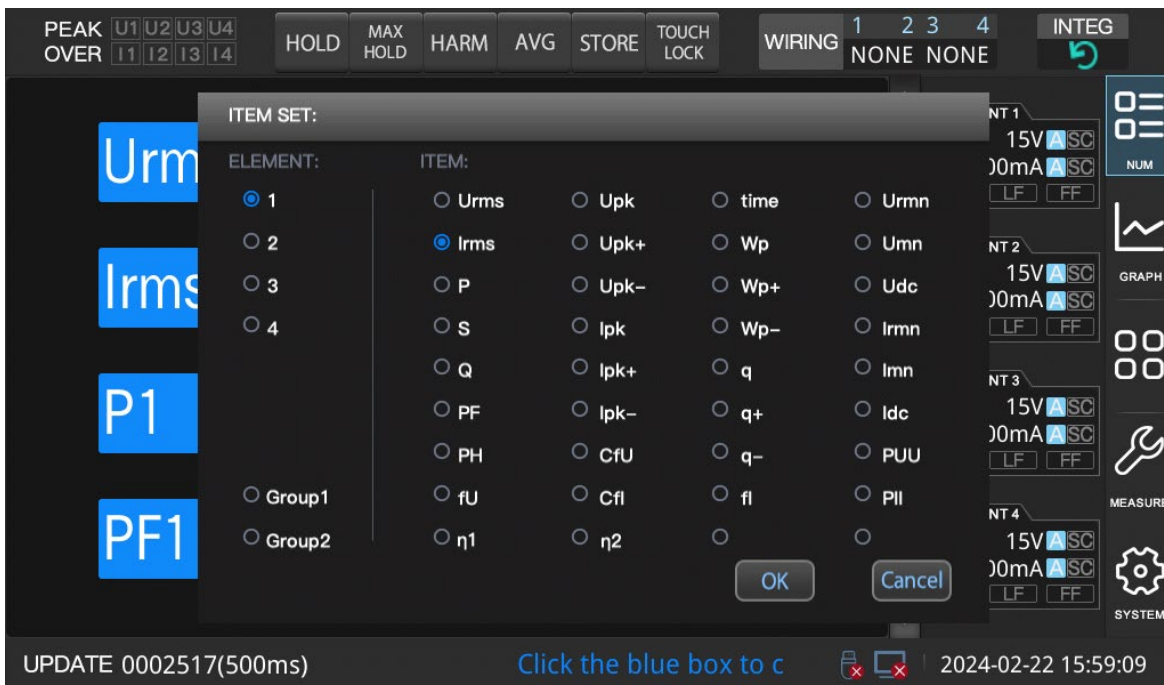

Figure 4.8 4-item option

- ③ The display item is set. The display in dashed frame area is changed from Urms1 to Irms1.

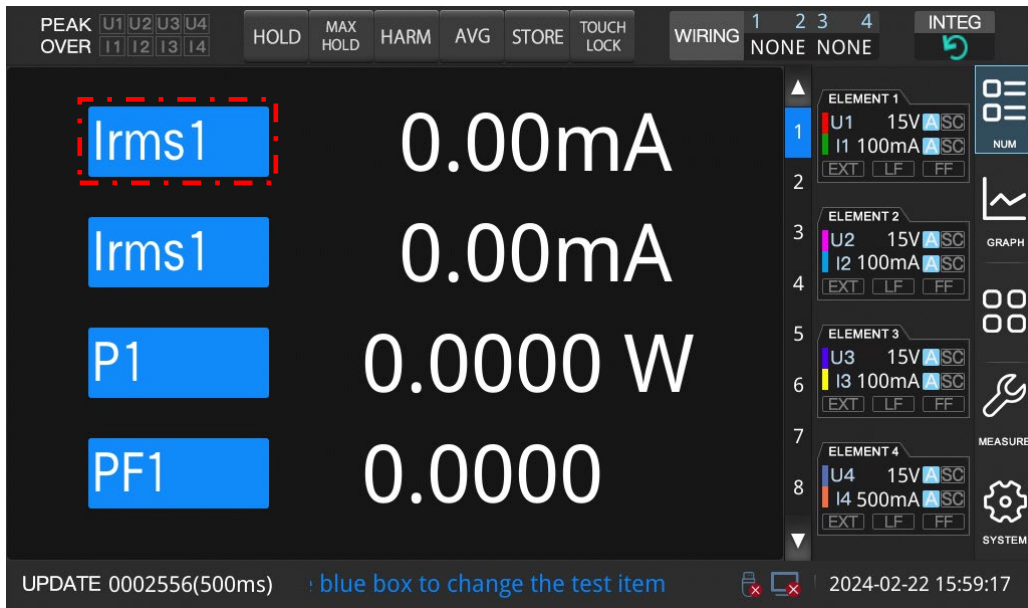

Figure 4.9 4-item display (after item change)

### 2. Meaning of measurement items

Table 4.1

Symbol	Meaning
Urms	Voltage effective value
Irms	Current effective value
P	Active power
S	Apparent power
Q	Reactive power
PF	Power factor
PH	Phase angle
fU	Voltage frequency
fI	Current frequency
Upk	Peak voltage
Upk+	Positive peak voltage
Upk-	Negative peak voltage
Ipk	Peak current
Ipk+	Positive peak current
Ipk-	Negative peak current

## Section 4 Operation

CfU	Voltage crest factor
CfI	Current crest factor
time	Electric energy accumulation time
timeL	Electric energy accumulation time to reach current threshold
Wp	Sum of integral positive/negative electric energy
Wp+	Accumulated positive electric energy
Wp-	Accumulated negative electric energy
q	Sum of integral positive/negative electricity
q+	Accumulated positive electricity
q-	Accumulated negative electricity
Urmn	RMN of voltage
Umn	Mean of voltage
Udc	Voltage DC component (average)
Irmn	RMN of current
Imn	Mean of current
Idc	Current DC component (average)
PUU	Voltage phase angle
PII	Current phase angle
$\eta 1$	Efficiency 1
$\eta 2$	Efficiency 2
1~4	1~4 channels
Group1	Three-phase Group 1
Group2	Three-phase Group 2

### III. Set basic measurement conditions

#### 1. Set wiring

##### 1) Function introduction

To measure the power of various single-phase/three-phase modes, the 87400 high-precision power analyzer provides 5 multi-phase multi-wire wiring modes: single-phase 2-wire (1P2W), single-phase 3-wire (1P3W), three-phase 3-wire (3P3W), three-phase 3-wire (3-voltage 3-ammeter, 3P3W (3V3A)) and three-phase 4-wire system (3P4W).

##### 2) Wiring switch

① Press the right MEASURE button, the Measure menu appears, as follows

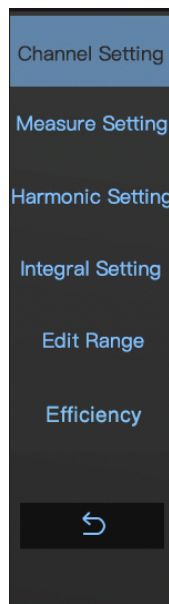

Figure 4.10 Measure Setting menu

② Click Measure Setting menu to enter Measure Setting screen.



Figure 4.11 Wiring setting

③ Select the wire system for each channel separately through the dropdown menu.

#### 2. Set voltage/current range

There are two modes for range setting:

One:

Set the voltage/current range via the buttons in Range area (Figure 4.12):

- (1) Click on the channel area interface to pop up a voltage and current range selection menu;
- (2) Adjust the voltage and current levels and automatic transmission through the RANGE area;
- (3) After the setting is completed, the corresponding channel display area will change.

Two:

- (1) Press the button MEASURE in the button area on the right side of the screen .
- (2) Set the range of Channel 1~4 via the pull-down menu in Range setting area, or press ALL to set all channels at the same time.

U-RANGE	15V	15V	15V	15V	1000V
I-RANGE	100mA	50mV	50mA	50mA	20A

Figure 4.12 Range setting area

### 3. Set external current sensor (BNC input)

#### 1) Function introduction

When the current measurement is greater than the meter range, different types of transformers and sensors may be chosen for measuring together with the power analyzer. Now different channel may be chosen as follows:

Table 4.2 Common current measurement methods

External input device	Remark	Channel
<b>Shunt current transformer</b>	Also known as a shunt, it connects precision resistors with small impedance in series in the current signal circuit to be measured; when a current signal to be measured passes through the resistor, the voltage across the resistor can be measured, and the current to be measured can be calculated according to Ohm's law.	Current channel
<b>Split core type current transformer (Voltage output)</b>	Used for field testing without disassembling the tested circuit, easy to operate. It can transform the current into a magnetic field signal with a fixed function, and then transform the magnetic field signal into a voltage or current with a function relationship; thereby measuring the current.	BNC channel
<b>Split core type current transformer (current output)</b>		Current channel
<b>CT (current transformer)</b>	Convert the primary current with large value into a secondary current with smaller value through a ratio for measurement	Mainly current channels, or BNC channel for some special specifications

When using BNC channels, the current source needs to be set to BNC mode.

#### 2) Operation

- ① Press the button MEASURE on the keypad to enter Channel Setting screen.
- ② In Current Source area, you can set current source1~4 via pull-down menu. When using the BNC channel, set the current source to "BNC", as shown in the figure below, set channel 2 and 4 to BNC mode. You can select ALL to set all channels at the same time.

Current Source	CUR	CUR	CUR	CUR	CUR
----------------	-----	-----	-----	-----	-----

Figure 4.13 Current source setting area

### 4. Set voltage/current ratio

#### (1) Function introduction

The user can measure the signal through a voltage transformer or a current transformer, and then convert the voltage/current before voltage/current transformation. Among them, the current and the external input BNC

ratio need to be set separately.

### (2) Operation method

- ① Press the button MEASURE on the keypad to enter Channel Setting screen.
- ② In Voltage ratio area, you can set the ratio of Channel 1~4 via the keyboard, as shown in the figure below. You can select ALL to set all channels at the same time.

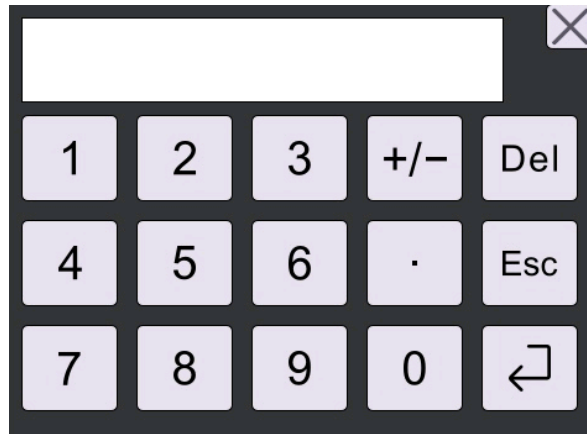

Figure 4.14 Keyboard

Set ranges of voltage, current and BNC ratios:

- Voltage ratio: 1~50000.0;
- Current ratio: 1~50000.0;
- BNC ratio: 0.01~100.000, mV/A;

For example, when a voltage output type current transformer with a voltage output of 10mV for 1A current measurement is used to measure 100A current, the output voltage is  $10\text{mV/A} \times 100\text{A} = 1\text{V}$ , and the transformer ratio is 10mV/A.

## 5. Set LINE filter and FREQ filter

### (1) Function introduction

Filters can be used to remove noise in the measurements. The LINE filter works in the voltage/current measurement circuit, and the FREQ filter works in the frequency measurement circuit.

The FREQ filter affects the frequency measurement in the frequency measurement circuit. Since this filter is not in the measurement circuit of voltage, current and power, even if the FREQ filter is turned on, the measurements will contain high frequency components.

### (2) Operation method

- ① Press the button MEASURE on the keypad to enter Channel Setting screen.
- ② In LINE/FREQ filter area, you can set the filter of Channel 1~4 via the keyboard, as shown in the figure below. You can select ALL to set all channels at the same time.

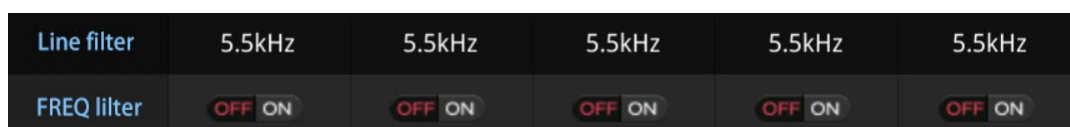

Figure 4.15 Filter setting area

Where the LINE filter can be set to 500Hz or 5.5kHz optional, and the FREQ filter is 500Hz after turn on.

### 6. Set simultaneous source

#### (1) Function introduction

The selection of simultaneous source affects the measurement interval. The simultaneous input signal (simultaneous source) passes from the initial point of the rising slope (or falling slope) that crosses the zero point (intermediate of amplitude) to the last point of the rising slope (or falling slope) that crosses the zero point (intermediate of amplitude) in the update cycle. If there is no or only one zero-crossing point in the update cycle, the entire update cycle is the measurement interval.

After selecting the input unit for the simultaneous source, select and set the simultaneous source from the following: U1, I1, U2, I2, U3, I3, U4, I4 or None.

If improper simultaneous source is set, the measurement may be unstable or wrong.

#### (2) Operation method

- ① Press the button MEASURE on the keypad to enter Channel Setting screen.
- ② In Simultaneous Source area, you can set the simultaneous source of Channel 1~4 via the keyboard, as shown in the figure below. You can select ALL to set all channels at the same time.

#### (3) Precautions

- ① The simultaneous source is set to U1 by default. When Channel 1 works normally, the simultaneous source is U1.

### 7. Set crest factor

#### Method

- ① Press the button MEASURE on the keypad to enter Channel Setting screen.
- ② Click Measure menu to enter Measure screen.
- ③ Click Crest Factor drop-down menu to select: CF3 or CF6 mode, as shown in the figure below.



Figure 4.16 Crest factor

### 8. Set update cycle

#### (1) Function introduction

The user needs to set the update cycle according to the measurement needs. With fast update, faster load changes in the power system can be obtained; with low update, sample data in several cycles of longer signal can be obtained.

#### (2) Operation method

- ① Press the button MEASURE on the keypad to enter Channel Setting screen.
- ② Click Measure menu to enter Measure screen.
- ③ Click Calculation cycle drop-down menu to select: 100ms~10s.

### 9. Set efficiency formula

#### (1) Function introduction

This instrument can measure two sets of efficiency simultaneously. The user can set the numerator and denominator of the efficiency formula as needed, and the efficiency can be read directly through display and/or communication.

(2) Operation method

- ① Press the button MEASURE on the keypad to enter Channel Setting screen.
- ② Click the right Efficiency Calculation menu to enter Efficiency Formula screen.
- ③ Get the required efficiency value by clicking the adjustment formula.

**10. Set AVG (average)**

(1) Function introduction

When the power or load changes greatly or the input signal frequency is low, the value display is unstable and difficult to read. In this case, the average function can be enabled to obtain and display the mean of multiple measurements. If the input signal changes sharply, the response of measurement to the change will become slower.

(2) Average calculation

① Exponential average

The user can set the attenuation coefficient to exponentially average the effective value of voltage/current RMS and the instantaneous value of active power (sampled data) to remove the high-frequency components of measurements. The larger the attenuation coefficient, the better the noise removal effect; but the measurement delay will be correspondingly longer.

② Attenuation constant or average number

Users need to configure related parameters to use the averaging function. If the average type is Exp (exponential average), set the attenuation coefficient; if it is Lin (moving average), set the average number. For both the attenuation coefficient of exponential average or the average number of moving average, the larger the setting, the more stable the measurement, and the slower the response speed to input changes.

③ Calculation formula

$$D_n = (M_{n-(m-1)} + M_{n-(m-2)} + \dots + M_{n-2} + M_{n-1} + M_n) / m$$

Exponential average formula:

$$D_n = D_{n-1} + (M_n - D_{n-1}) / K$$

The variables are shown in the following table:

Table 4.3 Variables of average formula

Symbol	Remark
$D_n$	$n^{\text{th}}$ display
$M_n$	$n^{\text{th}}$ measurement
$D_{n-1}$	Display after $n-1^{\text{th}}$ exponential average
$M_{n-(m-1)}$	Measurement that is $m-1$ time earlier than the $n^{\text{th}}$ measurement
$M_{n-(m-2)}$	Measurement that is $m-2$ time earlier than the $n^{\text{th}}$ measurement
$M_{n-2}$	Measurement that is 2 times earlier than the $n^{\text{th}}$ measurement



$M_{n-1}$	Measurement that is 1 time earlier than the $n^{\text{th}}$ measurement
K	Average coefficient
m	Average coefficient

### ④ Measurement with average function

Measurement with average function: U, I, P, S, and Q.

### (3) Steps

- ① Press the button MEASURE on the keypad to enter Channel Setting screen.
- ② Click Measure menu to enter Measure screen.
- ③ Set the average ON/OFF, calculation mode, and average coefficient by clicking.



Figure 4.17 Average function

## 11. Set MAXHOLD

### (1) Function introduction

The user can hold the maximum data with this function.

Valid for the following values:

Urms、Umn、Upk、Upk+、Upk-

Irms、Imn、Ipk、Ipk+、Ipk-

P、S、Q

### (2) Operation method

Method 1:

- ① Press the button MEASURE on the keypad to enter Channel Setting screen.
- ② Click Measure menu to enter Measure screen.
- ③ Switch MAXHOLD ON/OFF by clicking.



Figure 4.18 MAXHOLD

Method 2:

Click the MAX HOLD button in the function indicator area above the testing interface to switch to the maximum value holding function.

### 12. HOLD and single measurement

#### (1) Function introduction

The user can hold the data with this function.

#### (2) Operation

HOLD ON: Press HOLD button in the button area to enter HOLD state.

Disable HOLD: Press HOLD in HOLD state to disable HOLD.

### 13. Parameter initialization

#### (1) Function introduction:

Initialize all measurement settings and system settings.

#### (2) Operation method

- ① Press the "SYSTEM" test setting button in the right button area to enter the system settings interface.
- ② Touch and click on the "Host Settings" item in the menu on the right side of the screen to enter the host settings interface.
- ③ Restore factory settings through touch for parameter initialization.

### 14. Zeropoint acquisition

#### (1) Function introduction

Resetting is required before measuring using the instrument. Resetting is to instruct the input signal in the internal circuit of high-precision power analyzer to be zero, thereby improving the accuracy of the instrument. There are two resetting methods: automatic and manual.

With automatic resetting, the instrument will automatically perform resetting after changing the measurement range and input filter. If the same measurement range and input filter are used for long time, the zero level of the power analyzer may change due to changes in the surrounding environment. In this case, manual resetting must be performed.

#### (2) Manual resetting

- ① Press the "SYSTEM" test setting button in the right button area to enter the system settings interface.
- ② Touch and click on the "Host Settings" item in the menu on the right side of the screen to enter the host settings interface.
- ③ Manually adjust the zero point by touching the zero point acquisition.

### 15. Set effective measurement range

#### (1) Function introduction

The effective range of 87400(F) analyzer can be chosen. During the automatic shift, only the selected ranges are switched in cycle, and the unselected ranges are skipped, shortening the shifting time and improving the efficiency.

#### (2) Operation method

- ① Press the button MEASURE on the keypad to enter Channel Setting screen.
- ② Click the right Edit Range menu to enter Edit Range screen.

- ③ Select the type (voltage/current) of the range to be changed.

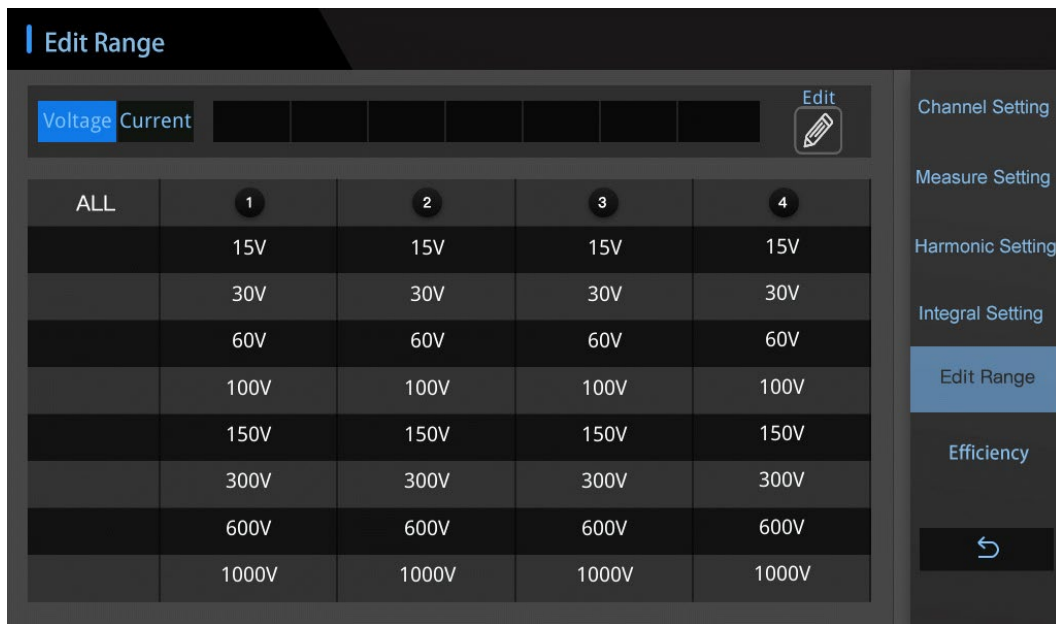

Figure 4.19 Edit Range screen

Select the model of board when selecting the current channel.

- ④ Click the right Edit after selecting the type and board to enter Edit Range screen, as shown below. Then enable the range to be used as needed, and click Exit to save after setting.

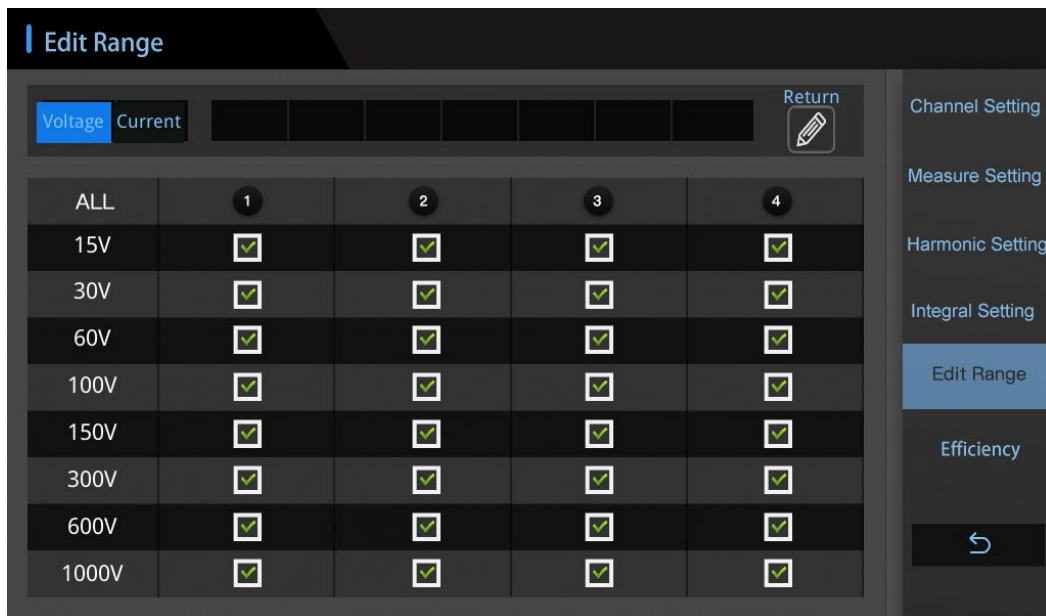

Figure 4.20 Edit Range area

## 16. TOUCHLOCK

- (1) Function introduction:

Press TOUCHLOCK to lock touch and keys to prevent accidental touches on site.

- (2) Operation method

TOUCHLOCK: Press SHIFT button, the SHIFT LED is on. Press PAGE DOWN at this time to trigger TOUCHLOCK. At this time, the touch screen does not respond. Repeat to disable TOUCHLOCK.

## VI. INTEG function

The power analyzer can integrate the power and current of single-phase/three-phase wiring groups.

(1) INTEG output parameters

$W_p$ 、 $W_{p+}$ 、 $W_{p-}$



$q$ 、 $q^+$ 、 $q^-$

time、timeL

(2) INTEG state

The INTEG state can be obtained from the INTEG state icon on the upper part of numerical display, as shown in the following table:

Table 4.4 Energy INTEG state

State	Remark	Icon
RESET	Reset or preparation: The integration value display and the integration time display are reset after integration reset.	
START	Integration start: the integration is in progress	
STOP	Integration stop: displayed when integration is interrupted	

(3) Setting of integral parameters

**Integration time:** to set the integration timing. If it is set to 0, it will not be timed, and the cyclic integration mode is invalid.

**Integration mode:** Configure the integration mode before using the integration function, including standard NOR mode and CONT cycle mode. The NOR integration mode stops after the set time ends or when it is manually stopped. The CONT integration mode resets and restarts after the set time ends, until the stop button is pressed.

**Restart INTEG state:** If the integration is in START state when shutting down, the set INTEG state will be displayed after restarting.

**Three-phase current threshold:** when the current three-phase current exceeds this value, the electric energy will be accumulated, and the default is 0.

(4) Parameter setting

- ① Press the button MEASURE on the keypad to enter Channel Setting screen.
- ② Click the right INTEG Setting menu to enter INTEG Setting screen.
- ③ Operate the corresponding parameters by clicking.

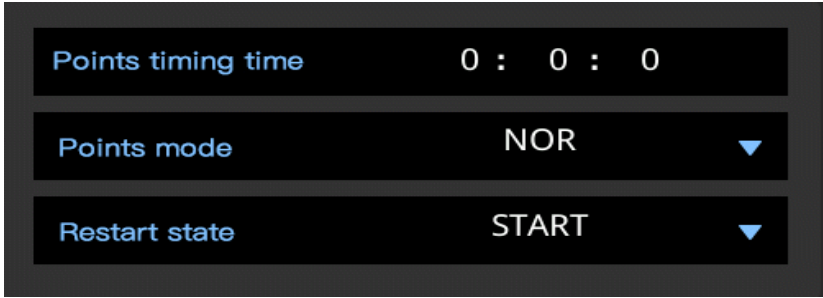

Figure 4.21 INTEG Setting area

(5) Manual INTEG mode

Press INTEG button in the function area to pop up the following menu, and operate by clicking.

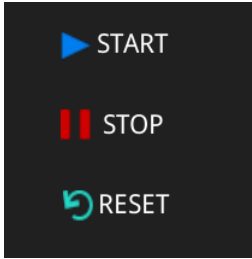

Figure 4.22 INTEG menu

V. HARM

(1) Function introduction

In HARM mode, the fundamental frequency within 600Hz can be measured up to the 100th harmonic. For specific parameters, see Section 2 Three. Technical Parameters.

The accuracy of conventional measurements will be slightly impacted in HARM mode. For details, see Section Two Four. Impact of System Settings on Measurement Accuracy.

(2) HARM display

The harmonics are displayed on the list screen as shown in the figure below:

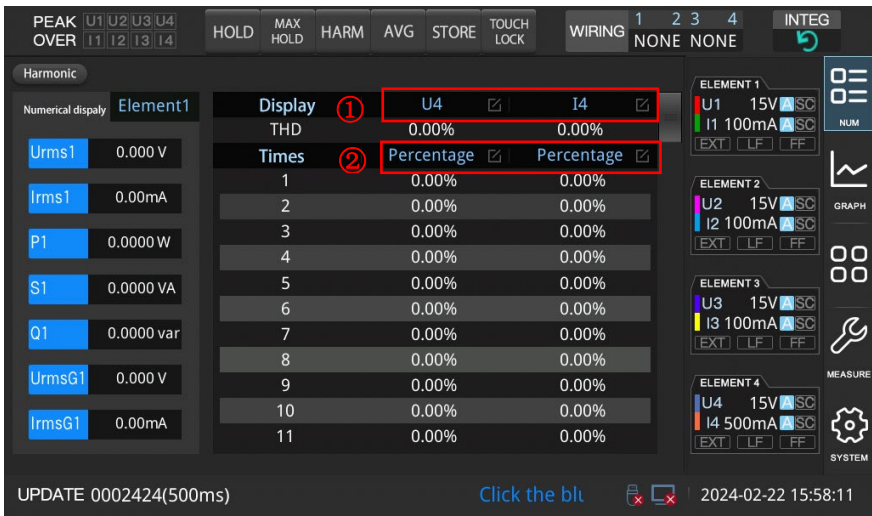

Figure 4.23 HARM display

The voltage/current total harmonic distortion and single harmonic parameters can be displayed simultaneously. The display channel is set at the above icon marking (1), and the 100th harmonic content or the RMS of

harmonic can be selected, marking (2). Control the display times of the current screen by sliding the right scroll bar.

(3) Set HARM measurement parameters

- Parameter description

### Select PLL source

In HARM mode, the power analyzer uses PLL (Phase Locked Loop) to multiply the frequency of the input signal, and uses the multiplied output signal as the sampling clock of the A/D in the instrument for synchronous sampling. Therefore, the frequency of PLL source signal determines the A/D sampling clock in the instrument, and the quality of PLL source signal also affects the stability and accuracy of the sampled data. The 87400(F) power analyzer supports two independent PLL sources to measure two different signals at the same time.

### PLL source options

The PLL source can be selected from the following options (depending on the installed number of input units): frequency of U1, I1, U2, I2, U3, I3, U4, I4 and other signal are used as the fundamental frequency for harmonic measurement.

### Level of PLL source signal

If the level of PLL source is too small compared with the range of the measured signals, the PLL will not be able to synchronize with the PLL source. For the power analyzer, the level of PLL source must exceed at least 50% of the range of measured signals.

### Change of PLL source frequency and measurement

If the frequency of PLL source changes, the PLL circuit inside the instrument needs to re-check the frequency of PLL source, so the correct measurement may not be obtained immediately, and it will only be displayed 200ms~2s after change of the frequency.

### Harmonic order

The user can specify the harmonic order, which mainly affects the times THD participates in the calculation.

### THD calculation mode

The IEC mode is chosen to calculate the ratio of rms of 2~100th harmonic components to the fundamental rms;

The CSA mode is chosen to calculate the ratio of rms of 2~100th harmonic components to the 1<sup>st</sup>~100th harmonics;

IEC's THD calculation formula: 
$$\frac{\sqrt{\sum_{k=2}^n (C_k)^2}}{C_1}$$
 CSA's THD calculation formula: 
$$\frac{\sqrt{\sum_{k=2}^n (C_k)^2}}{\sqrt{\sum_{k=1}^n (C_k)^2}}$$

- Parameter setting

- ① Press the button MEASURE on the keypad to enter Channel Setting screen.
- ② Click the right HARM Setting menu to enter HARM Setting screen.
- ③ Operate the corresponding parameters by clicking.

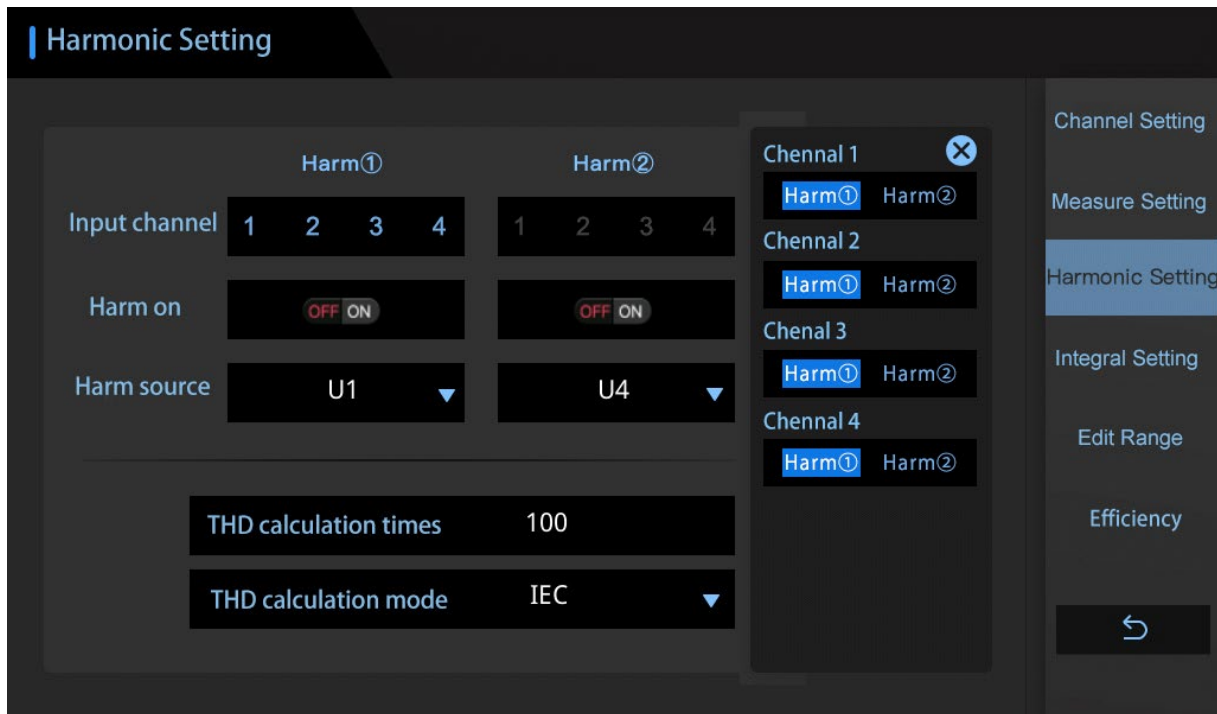

Figure 4.24 HARM Setting area

#### (4) HARM ON

The harmonic function of 87400(F) analyzer needs to be enabled manually. Click HARMONIC to enable/disable the harmonic measurement. If it is detected that the harmonic enable switch of neither Group 1 nor Group 2 are enabled, HARMONIC will automatically be disabled.

## VI. Waveform display

### (1) Function introduction

The power analyzer displays the waveform based on the sampled data, and you can choose to display/hide the voltage/current of each input unit. The Waveform Display screen includes a vertical axis and a horizontal axis.

#### Vertical axis (amplitude)

The display interval in the vertical axis direction is determined based on the specified range. The user can zoom in/out the waveform by setting the range of vertical axis.

#### Horizontal axis (time)

The horizontal axis of power analyzer is the time axis. The horizontal axis has 6 grids on one screen. The user can set the range of time axis to zoom in/out the waveform.

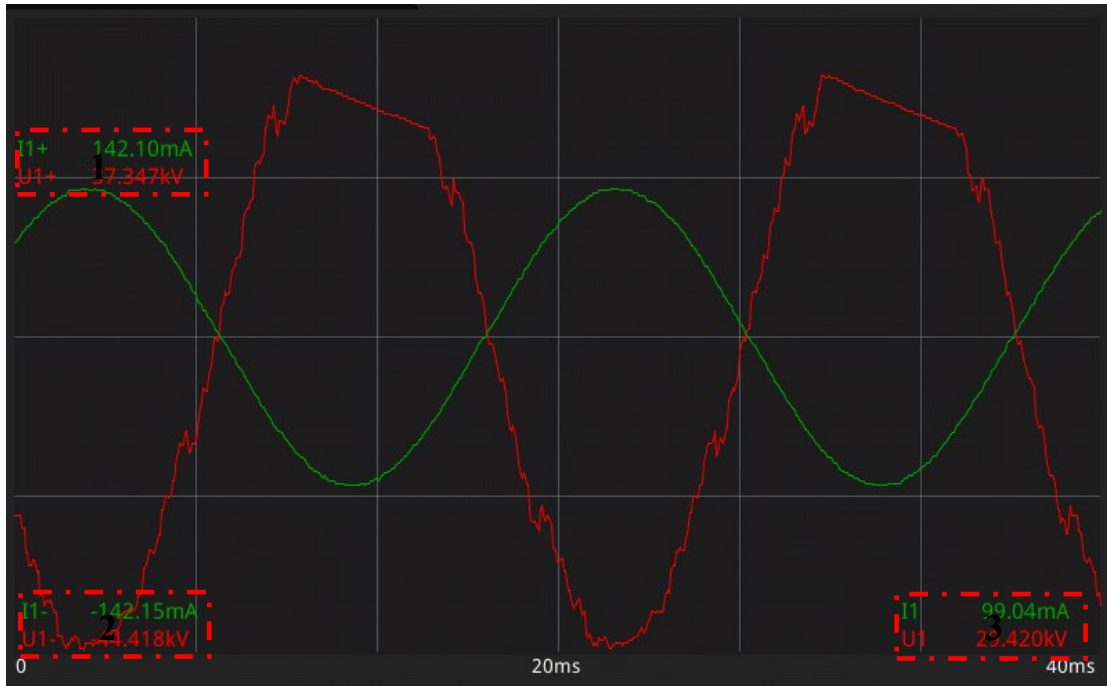

Figure 4.25 Waveform Display screen

Area 1 in the figure represents the positive peak of the signal

Area 2 in the figure represents the negative peak of the signal

Area 3 in the figure represents the RMS of the signal

Note: The waveform display is invalid when the harmonic function is ON.

### (2) Set waveform display conditions

Curve accuracy: The 87400(F) analyzer has two modes: 2-curve and 4-curve. The 2-curve waveform has more data and are detailed. The 4-curve has less wave points than the 2-curve mode. To observe the details of the two curves, it is recommended to use the 2-curve mode. It is recommended to use the 4-curve mode when comparing trends and simultaneous characteristics of multiple curves.

X-axis range: There are 0.2 times, 0.6 times and 1 times the calculation cycle. For example, when the calculation period is set to 500ms and the X-axis range is selected as 0.2 times, the coordinate range of the horizontal axis is 0-100ms.

Y-axis range: There are 1.5 times, 2 times and 3 times range. For example, when the crest factor is fixed at 3 and the voltage range is set to "100Vrms", taking the input zero line as the center, the upper limit of display interval is 300Vpk ( $100V_{rms} \times 3$ ), the lower limit is -300Vpk ( $-100V_{rms} \times 3$ ), and the waveform beyond this interval will be clipped.

Display mode: There are two display modes: full-screen and U/I split-screen. In full-screen display, the voltage/current are in one image. In U/I split-screen display mode, the voltage is displayed in the upper and the current is displayed in the lower.

Item Setting: select item ON and type.

### (3) Setting steps

Press MENU button in Waveform Display screen, and click Wave Settings in the right pop-up menu to enter Waveform Setting screen.



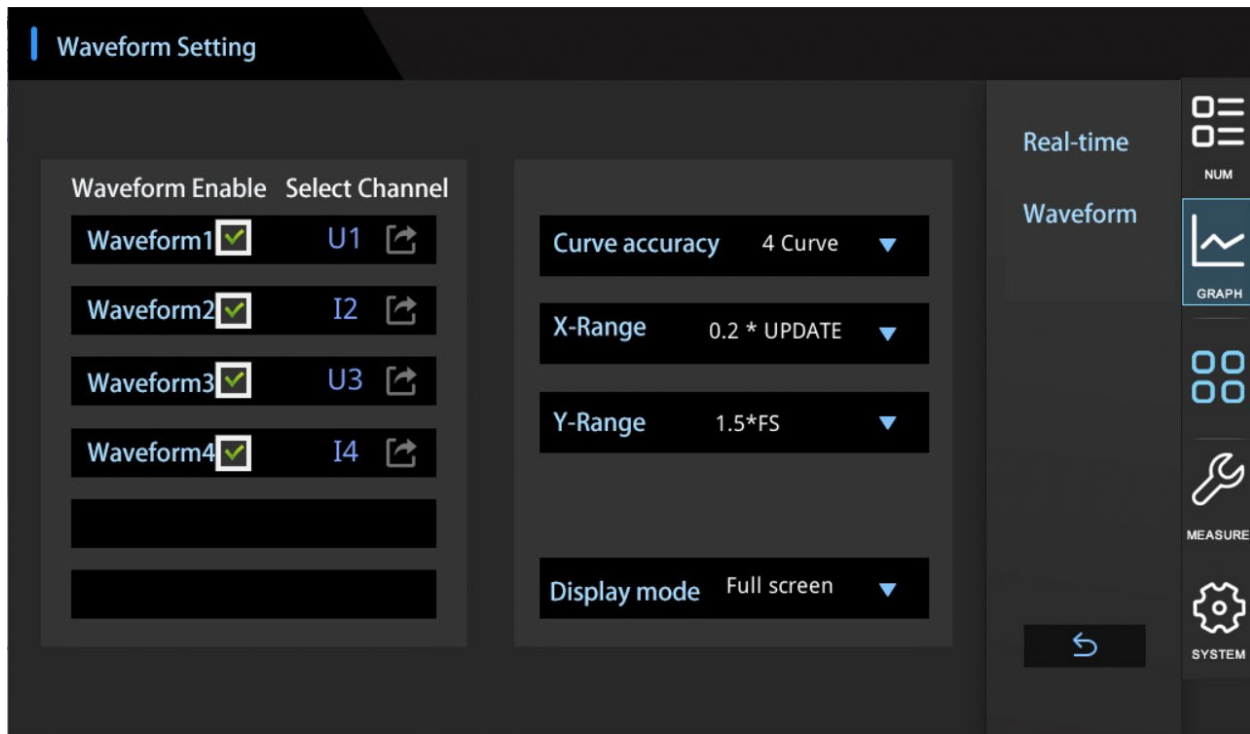

Figure 4.26 Waveform Setting screen

## VII. STORE

### (1) Function introduction

The 87400(F) analyzer supports U-disk. The measurement parameters can be directly written into U-disk and stored in CSV format. The stored items can be edited, flexible and convenient.

### (2) Storage setting

**Naming rules:** There are two file naming formats for storage: date (for example: 20210521) and date + time (for example: 20210521081022). For naming with date, the data stored on the day will be saved to the same file. The storage serial number will be re-accumulated for repeated storage. For naming with date + time, a new file will be created every time the storage is started.

**Storage item:** It is necessary to edit the storage item before storing, and the user can set it by himself.

#### Storage mode:

- Continuous storage mode: Store continuously after startup, up to 10W pieces of data can be stored.
- Store by time: timing starts after start storing, and stop storing after timing ends.
- Store by times: stop storing after reaching the designated storage times.

### (3) Setting method

- ① Press the button SYSTEM on the keypad to enter System Setting screen.
- ② Click the right Store Setting menu to enter Store Setting screen.
- ③ Set the corresponding parameters by clicking.

### (4) Storage format

No.	Time	Urms [1] (V)	Irms [1] (A)	mPrms [1] (W)	WS [1] (W)	Q [1] (W)	FreqI [1] (Hz)	FreqU [1] (Hz)	Upk [1] (V)	Ipk [1] (mA)	Idc [1] (mA)	Umn [1] (V)
1	20220701-	0	0.408	0	0	0	0	0	0	1.695	0.005	0
2	20220701-	0	0.41	0	0	0	0	0	0	-1.758	-0.002	0
3	20220701-	0	0.41	0	0	0	0	0	0	2.077	-0.002	0
4	20220701-	0	0.408	0	0	0	0	0	0	1.784	0	0
5	20220701-	0	0.408	0	0	0	0	0	0	-1.707	0.014	0
6	20220701-	0	0.407	0	0	0	0	0	0	-1.758	0.003	0
7	20220701-	0	0.409	0	0	0	0	0	0	1.899	0	0
8	20220701-	0	0.407	0	0	0	0	0	0	1.656	0.003	0
9	20220701-	0	0.409	0	0	0	0	0	0	1.962	0	0
10	20220701-	0	0.408	0	0	0	0	0	0	-1.848	-0.01	0
11	20220701-	0	0.409	0	0	0	0	0	0	-1.72	-0.009	0
12	20220701-	0	0.407	0	0	0	0	0	0	1.809	0.01	0
13	20220701-	0	0.408	0	0	0	0	0	0	-1.695	0.012	0
14	20220701-	0	0.408	0	0	0	0	0	0	-1.809	0.014	0
15	20220701-	0	0.406	0	0	0	0	0	0	-1.822	0.018	0
16	20220701-	0	0.408	0	0	0	0	0	0	-1.733	0.016	0
17	20220701-	0	0.408	0	0	0	0	0	0	1.72	0.012	0
18	20220701-	0	0.408	0	0	0	0	0	0	-1.975	0.01	0
19	20220701-	0	0.408	0	0	0	0	0	0	-1.771	0.003	0
20	20220701-	0	0.408	0	0	0	0	0	0	-1.822	0.002	0
21	20220701-	0	0.409	0	0	0	0	0	0	1.835	-0.008	0
22	20220701-	0	0.408	0	0	0	0	0	0	1.835	0.011	0
23	20220701-	0	0.408	0	0	0	0	0	0	1.771	0.007	0
24	20220701-	0	0.408	0	0	0	0	0	0	-1.886	0.005	0
25	20220701-	0	0.407	0	0	0	0	0	0	2.001	0.005	0

Figure 4.27 Report format

### (5) Start storage mode

Check whether the U-disk LED at the bottom of the screen is on after inserting the U-disk. After confirming that the U-disk is scanned successfully, press SHIFT button, the SHIFT LED is on. Press HARMONIC at this time to enable the storage (STORE). Press it again to stop the storage.

## VIII. Communication settings

### (1) Function introduction

This machine supports serial port, network port, and optional GPIB conversion unit.

Support MOUBUS-RTU and MODBUS TCP protocol, and the SCPI protocol can be customized.

See Section VI Appendix to Protocol.

### (2) Setting method

- ① Press the button SYSTEM on the keypad to enter System Setting screen.
- ② Click the right Communication Setting menu to enter Communication Setting screen.
- ③ Set the corresponding parameters by clicking.

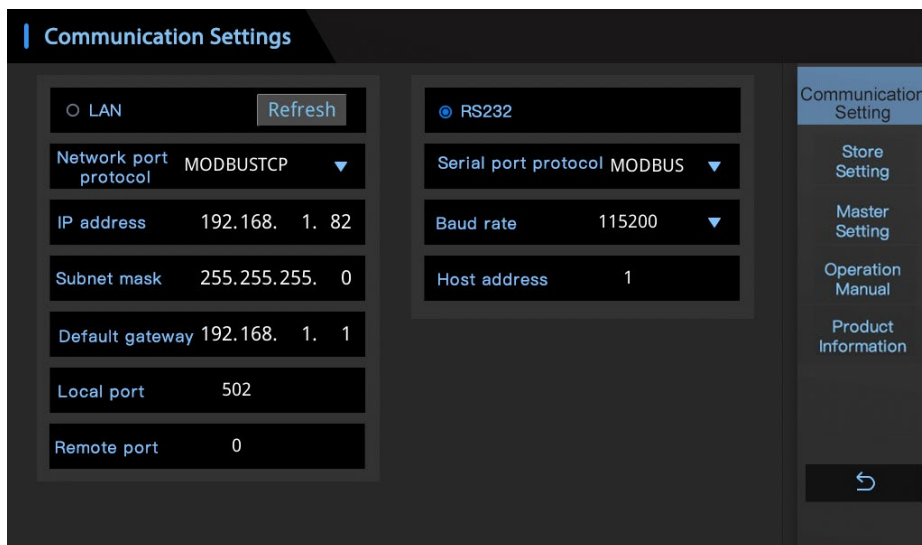

Figure 4.28 Communication Setting screen

Note: Click Refresh Network Port after any network port parameter is changed.

### IX Master settings

The software version can be viewed in the Master Setting screen, to perform self-check, language selection, system time setting, and screen brightness setting.

Setting method:

- ① Press the button SYSTEM on the keypad to enter System Setting screen.
- ② Click the right Master Setting menu to enter Master Setting screen.
- ③ Set the corresponding parameters by clicking.

### X. Operation Manual

The Product Instruction screen contains detail of main screen and detail of operations. For any problem found during the use of the instrument, read the corresponding instructions on this screen.

#### (1) Screen Introduction

Click Screen Introduction tab in the upper left corner to enter Screen Introduction screen. The meaning and function of each control of the measurement screen is described in a picture on this screen.

#### (2) FAQ

Click FAQ tab in the upper left corner of the screen to enter FAQ screen. This screen lists total 14 possible problems in daily use. Click the corresponding question, the operation steps will pop up on the right. Follow the steps to complete the corresponding operation.

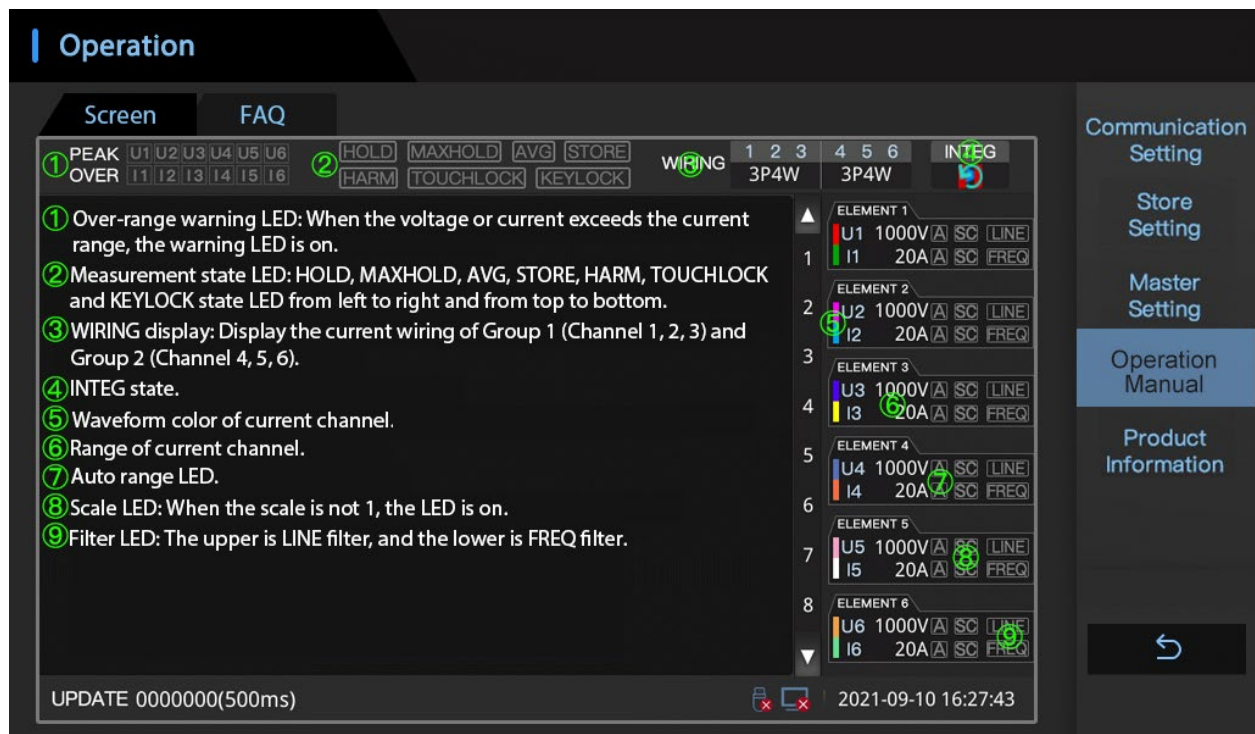

Figure 4.29 Instruction screen

## Section 5 External Interfaces

A 9-pin D-type port (male) is set on the rear panel of analyzer, providing RS-232 or RS-485 transmission and a LAN interface to provide network communication.

### I. RS-232/485 port

The analyzer is equipped with two serial ports: RS-232 and RS-485. The default port of 87400 analyzer is RS-232, and equipped with a standard RS-232 line. RS-485 line needs to be noted when ordering (dedicated RS-485 line will be delivered).

#### 1. Definition of RS-232 port

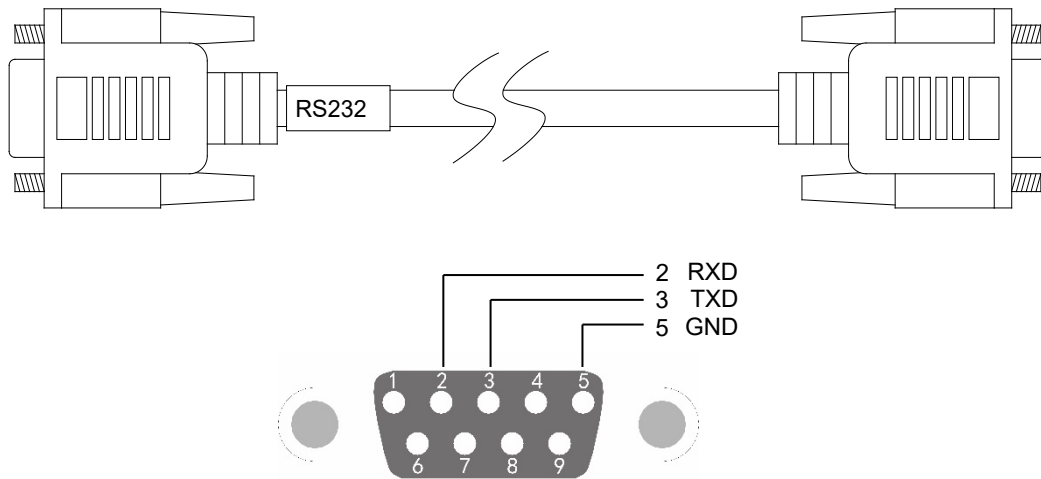
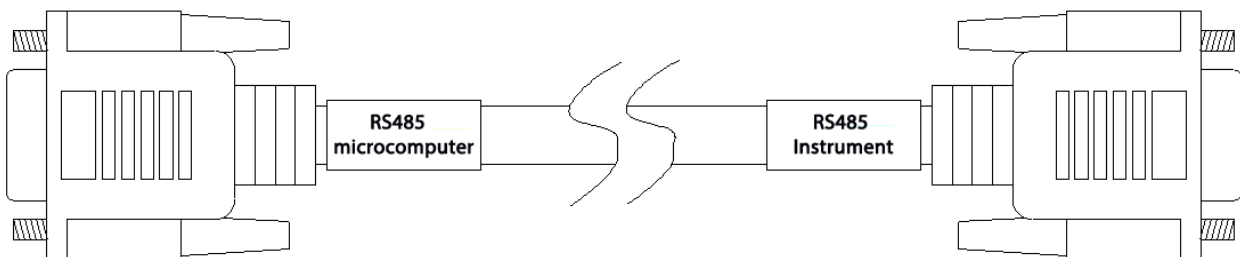

Figure 4-1 Definition of RS-232 port (same definition for computer side and instrument side)

Computer (9-pin female)	Instrument (9-pin female)
1	1
2	3
3	2
4	6
5	5
6	4
7	8
8	7
9	9
Metal shell	Metal shell (connected with metal shielding layer)

#### 2. Definition of RS-485 port



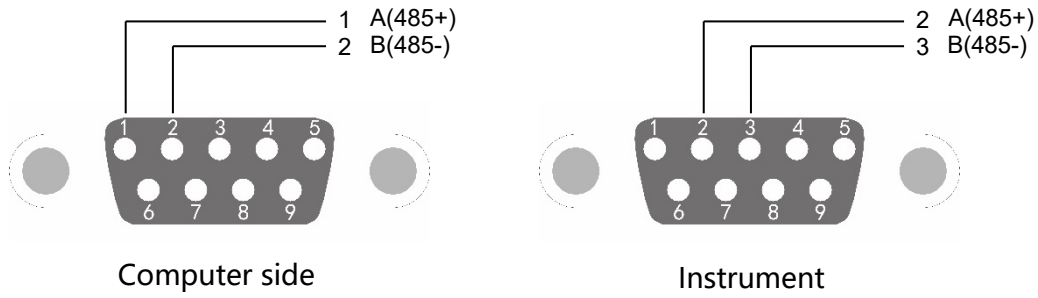

Figure 4-2 Definition of RS-485 port

Computer (9-pin female)	Instrument (9-pin female)
1	2
2	3
Metal shell	Metal shell (connected with metal shielding layer)

## II. Ethernet communication interface

Interface	RJ-45
Standard	IEEE802.3
Protocol	TCP/IP
Baudrate	10/100Mbps



**Caution** The address and baud rate of the instrument should be consistent with the settings of the master computer. The analyzer supports Modbus protocol and Modbus/TCP protocol. Other protocols need to be customized.

## Section 6 Appendix to Protocol

### I. Modbus RTU protocol

#### 1. Query

Note: (X in the protocol represents Channel 1-4 of the power analyzer. Not more than 100 bytes may be read each time, and only the parameters of each type can be read continuously. The harmonic content needs to be read separately, and the read measurements include voltage, current and BNC ratio)

#### 1.1 Format of frame

1.1.1 Reading the contents of instrument register (03H). See Table 1:

Sequence	Code	Example	Description
1	Instrument address	01H	Instrument communication address (01H-FFH, representing 1-255)
2	03H	03H	Function code(Query)
3	High byte of register start address	11H	Register start address 1100H
4	Low byte of register start address	00H	
5	High byte of register number	00H	Register number 02H
6	Low byte of register number	02H	
7	Low byte of CRC16	C1H	CRC
8	High byte of CRC16	37H	

Table 1

1.1.2 Frame returned by instrument (correct command), see Table 2:

Sequence	Code	Description
1	Instrument address	Instrument communication address (01H-FFH, representing 1-255)
2	03H	Function code(Query)
3	Return data byte (M)	
.....	Data of first register	
	Data of n <sup>th</sup> register	
M+4	Low byte of CRC16	
M+5	High byte of CRC16	

Table 2

1.1.3 Content returned by instrument (wrong command), see Table 3:

Sequence	Code	Example	Description
1	Instrument address	01H	Instrument communication address (01H-FFH, representing 1-255)
2	83H	83H	Function code(Query instruction error)
3	02H	02H	Error code
4	Low byte of CRC	C0H	
5	High byte of CRC	F1H	

Table 3

Error code:

- 01H——Function code error
- 02H——Command length error
- 03H - Read register error

#### 1.2 Register address

## Section 6 Appendix to Protocol

No.	Register address Hex.	Data description	Data Format	Register Number	Number of bytes	Remarks	Remark
1	1X00H	Voltage effective value (V)	Float32	2	4	Read only	Common parameters
2	1X02H	Current effective value (mA)	Float32	2	4	Read only	
3	1X04H	Power (W)	Float32	2	4	Read only	
4	1X06H	Power factor	Float32	2	4	Read only	
5	1X08H	Apparent power (Va)	Float32	2	4	Read only	
6	1X0AH	Reactive power (Var)	Float32	2	4	Read only	
7	1X0CH	Voltage frequency (HZ)	Float32	2	4	Read only	
8	1X0EH	Current frequency (HZ)	Float32	2	4	Read only	
9	1X10H	Phase angle (°)	Float32	2	4	Read only	
10	1X12H	RMN of voltage (V)	Float32	2	4	Read only	
11	1X14H	Average of voltage (V)	Float32	2	4	Read only	
12	1X16H	Voltage peak high point (V)	Float32	2	4	Read only	
13	1X18H	Voltage peak low point (V)	Float32	2	4	Read only	
14	1X1AH	Peak voltage (V)	Float32	2	4	Read only	
15	1X1CH	RMN of current (mA)	Float32	2	4	Read only	
16	1X1EH	Average of current (mA)	Float32	2	4	Read only	
17	1X20H	Current peak high point (mA)	Float32	2	4	Read only	
18	1X22H	Current peak low point (mA)	Float32	2	4	Read only	
19	1X24H	Peak current (mA)	Float32	2	4	Read only	
20	1X26H	Electric energy running time-hours	Float32	2	4	Read only	Electric energy parameters
21	1X28H	Electric energy running time-minutes	Float32	2	4	Read only	
22	1X2AH	Electric energy running time-seconds	Float32	2	4	Read only	
23	1X2CH	Positive electric energy (Wh)	Float32	2	4	Read only	
24	1X2EH	Negative electric energy (Wh)	Float32	2	4	Read only	
25	1X30H	Electric energy (Wh)	Float32	2	4	Read only	
26	1X32H	Positive electricity (mAh)	Float32	2	4	Read only	
27	1X34H	Negative electricity (mAh)	Float32	2	4	Read only	

## Section 6 Appendix to Protocol

28	1X36H	Electricity (mAh)	Float32	2	4	Read only	
34	2X00H	RMS of current fundamental wave (mA)	Float32	2	4	Read only	Harmonic parameters
35	2X02H	RMS of voltage fundamental wave (V)	Float32	2	4	Read only	
36	2X04H	RMS of power fundamental wave (W)	Float32	2	4	Read only	
37	2X06H	Total current harmonic distortion (%)	Float32	2	4	Read only	
38	2X08H	Total voltage harmonic distortion (%)	Float32	2	4	Read only	
39	2X0AH	Total power harmonic distortion (%)	Float32	2	4	Read only	
40	2X0CH	Fundamental apparent power (VA)	Float32	2	4	Read only	
41	2X0EH	Fundamental reactive power (var)	Float32	2	4	Read only	
42	2X10H	Fundamental power factor	Float32	2	4	Read only	
43	2X12H	U1 phase angle (°)	Float32	2	4	Read only	
44	2X14H	U2 phase angle (°)	Float32	2	4	Read only	
45	2X16H	U3 phase angle (°)	Float32	2	4	Read only	
46	2X18H	U4 phase angle (°)	Float32	2	4	Read only	
	2X1EH	I1 phase angle (°)	Float32	2	4	Read only	
	2X20H	I2 phase angle (°)	Float32	2	4	Read only	
	2X22H	I3 phase angle (°)	Float32	2	4	Read only	
	2X24H	I4 phase angle (°)	Float32	2	4	Read only	
49	2X2A~8EH	Current harmonic content*100(%) (1~100th, hex, read all at once, return 0BH, corresponding to 12, representing 0.12%)	int	50	100	Read only	
50	2X8F~F3H	Voltage harmonic content*100(%) (1~100th, hex, read all at once, return 0BH, corresponding to 12, representing 0.12%)	int	50	100	Read only	
51	3000H	Group A (Channel 1~3) three-phase total voltage (V)	Float32	2	4	Read only	Three-phase parameters
52	3002H	Group A three-phase total current (mA)	Float32	2	4	Read only	
53	3004H	Group A three-phase total power (W)	Float32	2	4	Read only	
54	3006H	Group A three-phase power factor	Float32	2	4	Read only	
55	3008H	Group A three-phase apparent power (VA)	Float32	2	4	Read only	
56	300AH	Group A three-phase reactive	Float32	2	4	Read	



## Section 6 Appendix to Protocol

		power (var)				only
	300CH	Group A three-phase total electric energy (Wh)	Float32	2	4	Read only
	300EH	Group A three-phase total electricity (Ah)	Float32	2	4	Read only
	3010H	Group B (Channel 4~6) three-phase total voltage (V)	Float32	2	4	Read only
	3012H	Group B three-phase total current (mA)	Float32	2	4	Read only
	3014H	Group B three-phase total power (W)	Float32	2	4	Read only
	3016H	Group B three-phase power factor	Float32	2	4	Read only
	3018H	Group B three-phase apparent power (VA)	Float32	2	4	Read only
	301AH	Group B three-phase reactive power (var)	Float32	2	4	Read only
	301CH	Group B three-phase total electric energy (Wh)	Float32	2	4	Read only
	301EH	Group B three-phase total electricity (Ah)	Float32	2	4	Read only
	3020H	Efficiency 1	Float32	2	4	Read only
	3022H	Efficiency 2	Float32	2	4	Read only

### 1.3 Example of communication data (all data below are in hex)

(1) Read voltage of the instrument (Channel 1)

A. Send from master

01H	03H	11H	00H	00H	02H	C1H	37H
Instrument address	Command	High/low bytes of start register address	High/low bytes of register number		High/low bytes of CRC		

B. Data returned by instrument: voltage=238.97V

01H	03H	04H	43H	6EH	F8H	A0H	CDH	D2H
Instrument address	Command	Number of bytes	4-byte integer, high byte first			CRC		

(2) Read the voltage, current, and power of instrument

A. Send from master

01H	03H	11H	00H	00H	06H	C0H	F4H
Instrument address	Command	High/low bytes of start register address	High/low bytes of register number		High/low bytes of CRC		

B. Data returned by instrument: voltage=230.8V, current=4.089A, power=943.88W

01H	03H	0CH	43,66,CD,C8-40,82,DD,6E-44,6B,F8,45	6FH	A2H
Instrument address	Command	Number of bytes	4-byte integer, high byte first	CRC	

## 2. Setting class

### 2.1 Frame format

2.1.1 Set the content of instrument register (06H), see Table 4

Sequence	Code	Example	Description
----------	------	---------	-------------

## Section 6 Appendix to Protocol

1	Instrument address	01H	Instrument communication address (01H-FFH, representing 1-255)
2	06H	06H	Function code(Settings)
3	High byte of register start address	20H	Register address 2000H
4	Low byte of register start address	00H	
5	Write high bytes of data	00H	Write data 01H (write BNC ratio data bit is four bytes, CRC is shifted by two bytes)
6	Write low bytes of data	01H	
7	Low byte of CRC16	43H	CRC
8	High byte of CRC16	CAH	

Table 4

2.1.2 Frame format returned by the instrument: If the writing is correct, the instrument returns the same frame format as Table 4.

2.1.3 The setting command is wrong, and the content returned by the instrument is shown in Table 5:

Sequence	Code	Example	Description
1	Instrument address	01H	Instrument communication address (01H-FFH, representing 1-255)
2	86H	86H	Function code(Wrong setting instruction)
3	03H	03H	Error code
4	High byte of CRC	02H	
5	Low byte of CRC	61H	

Table 5

Error code:

- 01H——Function code error
- 02H——Command length error
- 03H - Read register error
- 04H-Setting out of range error

### 2.2 Register address

No.	Register address Hex.	Data description	Data Format	Register Number	Number of bytes	Remarks	Remark
1	4000H	Integration time (minute: 0-2880, 48 hours)	int32	1	2	Write only	
2	4001H	Integral state (6 channels controlled simultaneously) (0-2: 0-Clear, 1-Start, 2-Stop)	int32	1	2	Write only	
3	4002H	First set load type (range: 0-4, 0-1P2W,1-1P3W, 2-3P3W, 3-3P4W, 4-3V3A)	int32	1	2	Write only	
	4003H	First set load type (range: 0-4, 0-1P2W,1-1P3W, 2-3P3W, 3-3P4W, 4-3V3A)	int32	1	2	Write only	
4	4004H	Calculation cycle (0-6: 0-0.1s, 1-0.2s, 2-0.5s, 3-1s, 4-2s, 5-5s, 6-10s)	int32	1	2	Write only	
	4005H	Synchronous measure master/slave selection (0-1: 0-Master, 1-Slave)	int32	1	2	Write only	
5	4006H	Channel 1 voltage range (0-7: 8 ranges of voltage (more than 7 means auto range). 0—15V, 1—30 V, 2—60 V, 3—100 V, 4—150 V, 5—300 V, 6— 600 V, 7—1000 V)	int32	1	2	Write only	

## Section 6 Appendix to Protocol

	~					
	4009H	Channel 4 voltage range (0-7: 8 ranges of voltage (more than 7 means auto range). 0—15V, 1—30 V, 2—60 V, 3—100 V, 4—150 V, 5—300 V, 6— 600 V, 7—1000 V)	int32	1	2	Write only
6	400CH	Channel 1 current range (0-7: 8 ranges of current (more than 7 means auto range).)	int32	1	2	Write only
	~					
	400FH	Channel 4 current range (0-7: 8 ranges of current (more than 7 means auto range).)				
7	4012H	Channel 1 current source (0-1: 0-BNC input, 1-Direct input)	int32	1	2	Write only
	~					
	4017H	Channel 4 current source (0-1: 0-BNC input, 1-Direct input)	int32	1	2	Write only
8	4018H	Channel 1 simultaneous source (0-9: 0-U1, 1-I1.....6—U4, 7—I4, 8-EXT,9-NULL)	int32	1	2	Write only
	~					
	401DH	Channel 4 simultaneous source (0-9: 0-U1, 1-I1.....6—U4, 7—I4, 8-EXT,9-NULL)	int32	1	2	Write only
9	401FH	First set harmonic source ((0-7: 0-U1, 1-I1, ... ,6-U4,7-I4)	int32	1	2	Write only
	4020H	First set harmonic source ((0-7: 0-U1, 1-I1, ... ,6-U4,7-I4)	int32	1	2	Write only
10	4021H	Group 1 harmonic ON/OFF (0-1: 0-OFF (normal measurement), 1-ON (harmonic measurement))	int32	1	2	Write only
	4022H	Group 2 harmonic ON/OFF (0-1: 0-OFF (normal measurement), 1-ON (harmonic measurement))	int32	1	2	Write only
11	4023H	Channel 1 FREQ filter (0-1: 0-OFF, 1-ON)	int32	1	2	Write only
	~					
	4028H	Channel 4 FREQ filter (0-1: 0-OFF, 1-ON)	int32	1	2	Write only
12	4029H	Channel 1 LINE filter (0-1: 0-OFF, 1-500Hz, 2-5.5kHz)	int32	1	2	Write only
	~					
	402EH	Channel 4 LINE filter (0-1: 0-OFF, 1-500Hz, 2-5.5kHz)	int32	1	2	Write only
13	402FH	Channel 1 voltage ratio (10-500000: 1~50000.0)	int32	1	2	Write only
			int32	1	2	Write only
	4034H	Channel 4 voltage ratio (10-500000: 1~50000.0)	int32	1	2	Write only
14	4035H	Channel 1 current ratio (10~50000: 1~50000.0)	int32	1	2	Write only
			int32	1	2	Write only
	403AH	Channel 4 current ratio (10~50000: 1~50000.0)	int32	1	2	Write only
15	403BH	Channel 1 BNC ratio (10-100000: 0.01~100.000)	int32	1	4	Write only
			int32	1	4	Write only
	4040H	Channel 4 BNC ratio (10-100000: 0.01~100.000)	int32	1	4	Write only

## Section 6 Appendix to Protocol

16	4041H	Average state (0-1: 0-OFF, 1-ON)	int32	1	2	Write only
17	4042H	Average calculation method (0-1: 0-Linear, 1-Exp)	int32	1	2	Write only
18	4043H	Total number of mean calculation (0-3: 0-8, 1-16, 2-32, 3-64)	int32	1	2	Write only
19	4044H	MAXHOLD (0-1: 0-OFF, 1-ON)	int32	1	2	Write only
20	4045H	HOLD (0-1: 0-OFF, 1-ON)	int32	1	2	Write only
21	4046H	THD mode (0-1: 0-IEC, 1-CSA)	int32	1	2	Write only
22	4047H	Maximum number of THD calculations (0-100)	int32	1	2	Write only
23	4048H	Peak factor(Range 0-1,0-3,1-4)	int32	1	2	Write only

### Setting class (read only)

No.	Register address Hex.	Data description	Data Format	Register Number	Number of bytes	Remarks	Remark
1	5000H	Integration time (minute: 0-2880, 48 hours)	Float 32	2	4	Read only	
2	5002H	Integral state (6 channels controlled simultaneously) (0-2: 0-Clear, 1-Start, 2-Stop)	Float 32	2	4	Read only	
3	5004H	First set load type (range: 0-4, 0-1P2W,1-1P3W, 2-3P3W, 3-3P4W, 4-3V3A)	Float 32	2	4	Read only	
	5006H	First set load type (range: 0-4, 0-1P2W,1-1P3W, 2-3P3W, 3-3P4W, 4-3V3A)	Float 32	2	4	Read only	
4	5008H	Calculation cycle (0-6: 0-0.1s, 1-0.2s, 2-0.5s, 3-1s, 4-2s, 5-5s, 6-10s)	Float 32	2	4	Read only	
5	500AH	Synchronous measure master/slave selection (0-1: 0-Master, 1-Slave)	Float 32	2	4	Read only	
6	500CH	Channel 1 voltage range (0-7: 8 ranges of voltage (more than 7 means auto range). 0—15V, 1—30 V, 2—60 V, 3—100 V, 4—150 V, 5—300 V, 6— 600 V, 7—1000 V)	Float 32	2	4	Read only	
	~						
	5016H	Channel 4 voltage range (0-7: 8 ranges of voltage (more than 7 means auto range). 0—15V, 1—30 V, 2—60 V, 3—100 V, 4—150 V, 5—300 V, 6— 600 V, 7—1000 V)	Float 32	2	4	Read only	
7	5018H	Channel 1 current range (0-7: 8 ranges of current (more than 7 means auto range).)	Float 32	2	4	Read only	
	~						
	5024H	Channel 4 current range (0-7: 8 ranges of current (more than 7 means auto range).)	Float 32	2	4	Read only	
8	5026H	Channel 1 current source (0-1: 0-BNC input, 1-Direct input)	Float 32	2	4	Read only	
	~						
	5030H	Channel 4 current source (0-1: 0-BNC input, 1-Direct input)	Float 32	2	4	Read only	

## Section 6 Appendix to Protocol

9	5032H	Channel 1 simultaneous source (0-9: 0-U1, 1-I1.....6-U4, 7-I4, 8-EXT,9-NULL)	Float 32	2	4	Read only
	~					
	503CH	Channel 4 simultaneous source (0-9: 0-U1, 1-I1.....6-U4, 7-I4, 8-EXT,9-NULL)	Float 32	2	4	Read only
10	503EH	First set harmonic source ((0-7: 0-U1, 1-I1, ... ,6-U4,7-I4)	Float 32	2	4	Read only
	5040H	First set harmonic source ((0-7: 0-U1, 1-I1, ... ,6-U4,7-I4)	Float 32	2	4	Read only
11	5042H	Group 1 harmonic ON/OFF (0-1: 0-OFF (normal measurement), 1-ON (harmonic measurement))	Float 32	2	4	Read only
	5044H	Group 2 harmonic ON/OFF (0-1: 0-OFF (normal measurement), 1-ON (harmonic measurement))	Float 32	2	4	Read only
12	5046H	Channel 1 FREQ filter (0-1: 0-OFF, 1-ON)	Float 32	2	4	Read only
	~					
	5050H	Channel 4 FREQ filter (0-1: 0-OFF, 1-ON)	Float 32	2	4	Read only
13	5052H	Channel 1 LINE filter (0-1: 0-OFF, 1-500Hz, 2-5.5kHz)	Float 32	2	4	Read only
	~					
	505CH	Channel 4 LINE filter (0-1: 0-OFF, 1-500Hz, 2-5.5kHz)	Float 32	2	4	Read only
14	505EH	Channel 1 voltage ratio (1.0-50000.0)	Float 32	2	4	Read only
	~					
	5068H	Channel 4 voltage ratio (1.0-50000.0)	Float 32	2	4	Read only
15	506AH	Channel 1 current ratio (1.0~50000.0)	Float 32	2	4	Read only
	~					
	5074H	Channel 4 current ratio (1~50000.0)	Float 32	2	4	Read only
16	5076H	Channel 1 BNC ratio (0.01~100.00)	Float 32	2	4	Read only
	~					
	5080H	Channel 4 BNC ratio (0.01~100.00)	Float 32	2	4	Read only
17	5082H	Average state (0-1: 0-OFF, 1-ON)	Float 32	2	4	Read only
18	5084H	Mean calculation method (0-1: 0-Linear, 1-Exp)	Float 32	2	4	Read only
19	5086H	Total number of mean calculation (0-3: 0-8, 1-16, 2-32, 3-64)	Float 32	2	4	Read only
20	5088H	MAXHOLD (0-1: 0-OFF, 1-ON)	Float 32	2	4	Read only
21	508AH	HOLD (0-1: 0-OFF, 1-ON)	Float 32	2	4	Read only
22	508CH	THD mode (0-1: 0-IEC, 1-CSA)	Float 32	2	4	Read only
23	508EH	Maximum number of THD calculations (0-100)	Float 32	2	4	Read only
24	5090H	Peak factor(Range 0-1,0-3,1-4)	Float 32	2	4	Read only

### 2.3 Example of communication data (all data below are in hex)

(1) Set type of load for Channel 1, 2, 3

Send by master: set to 1P3W

01H	06H	40H	02H	00H	01H	FCH	0AH
Instrument address	Command	High/low bytes of start register address		2-byte data bit		High/low bytes of CRC	

(2) Set voltage range

Send by master: set to 30V

01H	06H	40H	04H	00H	01H	1CH	0BH
Instrument address	Command	High/low bytes of start register address		2-byte data bit		High/low bytes of CRC	

## II. ModbusTCP protocol

### 1. Query

Note: (X in the protocol represents Channel 1-4 of the power analyzer. Not more than 100 bytes may be read each time, and only the parameters of each type can be read continuously. The harmonic content needs to be read separately, and the read measurements include voltage, current and BNC ratio)

#### 1.1 Format of frame

1.1.1 Reading the contents of instrument register (03H). See Table 1:

Sequence (bytes)	Code	Example	Description
1	Transaction identifier High type	00H	Identification of Modbus request response/response transaction (generated by client, original value returned by server)
2	Low byte of transaction identifier	01H	
3	High byte of protocol identifier	00H	0000 h = the Modbus Protocol
4	Low byte of protocol identifier	00H	
5	Data frame length High type	00H	Calculate the length from the 7 <sup>th</sup> byte
6	Low byte of data frame length	06H	
7	Instrument address	01H	Instrument communication address (01H-FFH, representing 1-255)
8	Function code	03H	Function code(Query)
9	High byte of register start address	11H	Register start address 1100H
10	Low byte of register start address	00H	
11	High byte of register number	00H	Register number 02H
12	Low byte of register number	02H	

Table 1

1.1.2 Frame returned by instrument (correct command), see Table 2:

Sequence (bytes)	Code	Description
1	Transaction identifier High type	Identification of Modbus request response/response transaction (generated by client, original value returned by server)
2	Low byte of transaction identifier	
3	High byte of protocol identifier	0000 h = the Modbus Protocol
4	Low byte of protocol identifier	
5	Data frame length High type	Calculate the length from the 7 <sup>th</sup> byte
6	Low byte of data frame length	
7	Instrument address	Instrument communication address (01H-FFH, representing 1-255)
8	03H	Function code(Query)
9	Return data byte (M)	
.....	Data of first register	
M+9	Data of n <sup>th</sup> register	

## Section 6 Appendix to Protocol

Table 2

1.1.3 Content returned by instrument (wrong command), see Table 3:

Sequence	Code	Example	Description
1	Transaction identifier High type	00H	Identification of Modbus request response/response transaction (generated by client, original value returned by server)
2	Low byte of transaction identifier	01H	
3	High byte of protocol identifier	00H	0000 h = the Modbus Protocol
4	Low byte of protocol identifier	00H	
5	Data frame length High type	00H	Calculate the length from the 7 <sup>th</sup> byte
6	Low byte of data frame length	03H	
7	Instrument address	01H	Instrument communication address (01H-FFH, representing 1-255)
8	83H	83H	Function code(Query instruction error)
9	02H	02H	Error code

Table 3

Error code:

- 01H——Function code error
- 02H——Command length error
- 03H - Read register error

### 1.2 Register address

No.	Register address Hex.	Data description	Data Format	Register Number	Number of bytes	Remarks	Remark
1	1X00H	Voltage effective value (V)	Float32	2	4	Read only	Common parameters
2	1X02H	Current effective value (mA)	Float32	2	4	Read only	
3	1X04H	Power (W)	Float32	2	4	Read only	
4	1X06H	Power factor	Float32	2	4	Read only	
5	1X08H	Apparent power (Va)	Float32	2	4	Read only	
6	1X0AH	Reactive power (Var)	Float32	2	4	Read only	
7	1X0CH	Voltage frequency (HZ)	Float32	2	4	Read only	
8	1X0EH	Current frequency (HZ)	Float32	2	4	Read only	
9	1X10H	Phase angle (°)	Float32	2	4	Read only	
10	1X12H	RMN of voltage (V)	Float32	2	4	Read only	
11	1X14H	Average of voltage (V)	Float32	2	4	Read only	
12	1X16H	Voltage peak high point (V)	Float32	2	4	Read only	
13	1X18H	Voltage peak low point (V)	Float32	2	4	Read only	
14	1X1AH	Peak voltage (V)	Float32	2	4	Read only	

## Section 6 Appendix to Protocol

15	1X1CH	RMN of current (mA)	Float32	2	4	Read only	Electric energy parameters	
16	1X1EH	Average of current (mA)	Float32	2	4	Read only		
17	1X20H	Current peak high point (mA)	Float32	2	4	Read only		
18	1X22H	Current peak low point (mA)	Float32	2	4	Read only		
19	1X24H	Peak current (mA)	Float32	2	4	Read only		
20	1X26H	Electric energy running time-hours	Float32	2	4	Read only		
21	1X28H	Electric energy running time-minutes	Float32	2	4	Read only		
22	1X2AH	Electric energy running time-seconds	Float32	2	4	Read only		
23	1X2CH	Positive electric energy (Wh)	Float32	2	4	Read only		
24	1X2EH	Negative electric energy (Wh)	Float32	2	4	Read only		
25	1X30H	Electric energy (Wh)	Float32	2	4	Read only		
26	1X32H	Positive electricity (mAh)	Float32	2	4	Read only		
27	1X34H	Negative electricity (mAh)	Float32	2	4	Read only		
28	1X36H	Electricity (mAh)	Float32	2	4	Read only		
34	2X00H	RMS of current fundamental wave (mA)	Float32	2	4	Read only		Harmonic parameters
35	2X02H	RMS of voltage fundamental wave (V)	Float32	2	4	Read only		
36	2X04H	RMS of power fundamental wave (W)	Float32	2	4	Read only		
37	2X06H	Total current harmonic distortion (%)	Float32	2	4	Read only		
38	2X08H	Total voltage harmonic distortion (%)	Float32	2	4	Read only		
39	2X0AH	Total power harmonic distortion (%)	Float32	2	4	Read only		
40	2X0CH	Fundamental apparent power (VA)	Float32	2	4	Read only		
41	2X0EH	Fundamental reactive power (var)	Float32	2	4	Read only		
42	2X10H	Fundamental power factor	Float32	2	4	Read only		
43	2X12H	U1 phase angle (°)	Float32	2	4	Read only		
44	2X14H	U2 phase angle (°)	Float32	2	4	Read only		
45	2X16H	U3 phase angle (°)	Float32	2	4	Read only		
46	2X18H	U4 phase angle (°)	Float32	2	4	Read only		
47	2X1EH	I1 phase angle (°)	Float32	2	4	Read only		
48	2X20H	I2 phase angle (°)	Float32	2	4	Read		



## Section 6 Appendix to Protocol

						only	
49	2X22H	I3 phase angle (°)	Float32	2	4	Read only	
50	2X24H	I4 phase angle (°)	Float32	2	4	Read only	
51	2X2A~8DH	Current harmonic content*100(%) (1~100th, hex, return 0BH, corresponding to 12, representing 0.12%)	int	50	100	Read only	
52	2X8E~F1H	Voltage harmonic content*100(%) (1~50 <sup>th</sup> , hex, return 0BH, corresponding to 12, representing 0.12%)	int	50	100	Read only	
53	3000H	Group A (Channel 1~3) three-phase total voltage (V)	Float32	2	4	Read only	Three-phase parameters
54	3002H	Group A three-phase total current (mA)	Float32	2	4	Read only	
55	3004H	Group A three-phase total power (W)	Float32	2	4	Read only	
56	3006H	Group A three-phase power factor	Float32	2	4	Read only	
57	3008H	Group A three-phase apparent power (VA)	Float32	2	4	Read only	
58	300AH	Group A three-phase reactive power (var)	Float32	2	4	Read only	
59	300CH	Group A three-phase total electric energy (Wh)	Float32	2	4	Read only	
60	300EH	Group A three-phase total electricity (Ah)	Float32	2	4	Read only	
61	3010H	Group B (Channel 4~6) three-phase total voltage (V)	Float32	2	4	Read only	
62	3012H	Group B three-phase total current (mA)	Float32	2	4	Read only	
63	3014H	Group B three-phase total power (W)	Float32	2	4	Read only	
64	3016H	Group B three-phase power factor	Float32	2	4	Read only	
65	3018H	Group B three-phase apparent power (VA)	Float32	2	4	Read only	
66	301AH	Group B three-phase reactive power (var)	Float32	2	4	Read only	
67	301CH	Group B three-phase total electric energy (Wh)	Float32	2	4	Read only	
68	301EH	Group B three-phase total electricity (Ah)	Float32	2	4	Read only	
69	3020H	Efficiency 1	Float32	2	4	Read only	
70	3022H	Efficiency 2	Float32	2	4	Read only	

### 1.3 Example of communication data (all data below are in hex)

(1) Read voltage of the instrument (Channel 1)

A. Send from master

0001H	0000H	0006H	01H	03H	11H	00H	00H	02H
-------	-------	-------	-----	-----	-----	-----	-----	-----

## Section 6 Appendix to Protocol

Transaction identifier	Modbus Protocol	Data frame length	Instrument address	Command	High/low bytes of start register address	High/low bytes of register number
------------------------	-----------------	-------------------	--------------------	---------	--	-----------------------------------

B. Data returned by instrument: voltage=238.97V

0001H	0000H	0007H	01H	03H	04H	43H	6EH	F8H	A0H
Transaction identifier	Modbus Protocol	Data frame length	Instrument address	Command	Number of bytes	4-byte integer, high byte first			

(2) Read the voltage, current, and power of instrument

A. Send from master

0001H	0000H	0006H	01H	03H	11H	00H	00H	06H
Transaction identifier	Modbus Protocol	Data frame length	Instrument address	Command	High/low bytes of start register address	High/low bytes of register number		

B. Data returned by instrument: voltage=230.8V, current=4.089A, power=943.88W

0001H	0000H	000FH	01H	03H	0CH	43,66,CD,C8-40,82,DD,6E-44,6B,F8,45			
Transaction identifier	Modbus Protocol	Data frame length	Instrument address	Command	Number of bytes	4-byte integer, high byte first			

## 2. Setting class

### 2.1 Frame format

2.1.1 Set the content of instrument register (06H), see Table 4

Sequence	Code	Example	Description
1	Transaction identifier High type	00H	Identification of Modbus request response/response transaction (generated by client, original value returned by server)
2	Low byte of transaction identifier	01H	
3	High byte of protocol identifier	00H	0000 h = the Modbus Protocol
4	Low byte of protocol identifier	00H	
5	Data frame length High type	00H	Calculate the length from the 7 <sup>th</sup> byte
6	Low byte of data frame length	06H	
7	Instrument address	01H	Instrument communication address (01H-FFH, representing 1-255)
8	06H	06H	Function code(Settings)
9	High byte of register start address	20H	Register address 2000H
10	Low byte of register start address	00H	
11	Write high bytes of data	00H	Write data 01H
12	Write low bytes of data	01H	

Table 4

2.1.2 Frame format returned by the instrument: If the writing is correct, the instrument returns the same frame format as Table 4.

2.1.3 The setting command is wrong, and the content returned by the instrument is shown in Table 5:

Sequence	Code	Example	Description
1	Transaction identifier High type	00H	Identification of Modbus request response/response transaction (generated by client, original value returned by server)
2	Low byte of transaction identifier	01H	
3	High byte of protocol identifier	00H	0000 h = the Modbus Protocol
4	Low byte of protocol identifier	00H	
5	Data frame length High type	00H	Calculate the length from the 7 <sup>th</sup> byte
6	Low byte of data frame length	03H	
7	Instrument address	01H	Instrument communication address (01H-FFH, representing 1-255)
8	86H	86H	Function code(Wrong setting instruction)
9	03H	03H	Error code

## Section 6 Appendix to Protocol

Table 5

Error code:

- 01H—Function code error
- 02H—Command length error
- 03H - Read register error
- 04H-Setting out of range error

### 2.2 Register address

No.	Register address Hex.	Data description	Data Format	Register Number	Number of bytes	Remarks	Remark
1	4000H	Integration time (minute: 0-2880, 48 hours)	int32	1	2	Write only	
2	4001H	Integral state (4 channels controlled simultaneously) (0-2: 0-Clear, 1-Start, 2-Stop)	int32	1	2	Write only	
3	4X02H	X(1~4) load type (range: 0-4, 0-1P2W,1-1P3W, 2-3P3W, 3-3P4W, 4-3V3A)	int32	1	2	Write only	
4	4X03H	X(1~4) load type (range: 0-4, 0-1P2W,1-1P3W, 2-3P3W, 3-3P4W, 4-3V3A)	int32	1	2	Write only	
5	4004H	Calculation cycle (0-6: 0-0.1s, 1-0.2s, 2-0.5s, 3-1s, 4-2s, 5-5s, 6-10s)	int32	1	2	Write only	
6	4005H	Synchronous measure master/slave selection (0-1: 0-Master, 1-Slave)	int32	1	2	Write only	
7	4006H	Channel 1 voltage range (0-7: 8 ranges of voltage (more than 7 means auto range). 0—15V, 1—30 V, 2—60 V, 3—100 V, 4—150 V, 5—300 V, 6— 600 V, 7—1000 V)	int32	1	2	Write only	
	~						
	4009H	Channel 4 voltage range (0-7: 8 ranges of voltage (more than 7 means auto range). 0—15V, 1—30 V, 2—60 V, 3—100 V, 4—150 V, 5—300 V, 6— 600 V, 7—1000 V)	int32	1	2	Write only	
8	400CH	Channel 1 current range (0-7: 8 ranges of current (more than 7 means auto range).)	int32	1	2	Write only	
	~						
	400FH	Channel 4 current range (0-7: 8 ranges of current (more than 7 means auto range).)					
9	4012H	Channel 1 current source (0-1: 0-BNC input, 1-Direct input)	int32	1	2	Write only	
	~						
	4015H	Channel 4 current source (0-1: 0-BNC input, 1-Direct input)	int32	1	2	Write only	
10	4018H	Channel 1 simultaneous source (0-9: 0-U1, 1-I1.....6—U4, 7—I4, 8-EXT,9-NULL)	int32	1	2	Write only	
	~						
	401BH	Channel 4 simultaneous source (0-9: 0-U1, 1-I1.....6—U4, 7—I4, 8-EXT,9-NULL)	int32	1	2	Write only	
11	401FH	First set harmonic source ((0-7: 0-U1, 1-I1, ... ,6-U4,7-I4)	int32	1	2	Write only	

## Section 6 Appendix to Protocol

12	4020H	First set harmonic source ((0-7: 0-U1, 1-I1, ... ,6-U4,7-I4)	int32	1	2	Write only	
13	4021H	Group 1 harmonic ON/OFF (0-1: 0-OFF (normal measurement), 1-ON (harmonic measurement))	int32	1	2	Write only	
14	4022H	Group 2 harmonic ON/OFF (0-1: 0-OFF (normal measurement), 1-ON (harmonic measurement))	int32	1	2	Write only	
15	4023H	Channel 1 FREQ filter (0-1: 0-OFF, 1-ON)	int32	1	2	Write only	
	~						
	4026H	Channel 4 FREQ filter (0-1: 0-OFF, 1-ON)	int32	1	2	Write only	
16	4029H	Channel 1 LINE filter (0-1: 0-OFF, 1-500Hz, 2-5.5kHz)	int32	1	2	Write only	
	~						
	402CH	Channel 4 LINE filter (0-1: 0-OFF, 1-500Hz, 2-5.5kHz)	int32	1	2	Write only	
17	402FH	Channel 1 voltage ratio (10-500000: 1~50000.0)	int32	1	2	Write only	
			int32	1	2	Write only	
	4032H	Channel 4 voltage ratio (10-500000: 1~50000.0)	int32	1	2	Write only	
18	4035H	Channel 1 current ratio (10~50000: 1~50000.0)	int32	1	2	Write only	
			int32	1	2	Write only	
	4038H	Channel 4 current ratio (10~50000: 1~50000.0)	int32	1	2	Write only	
19	403BH	Channel 1 BNC ratio (10-100000: 0.01~100.000)	int32	1	4	Write only	
			int32	1	4	Write only	
	403EH	Channel 4 BNC ratio (10-100000: 0.01~100.000)	int32	1	4	Write only	
20	4041H	Average state (0-1: 0-OFF, 1-ON)	int32	1	2	Write only	
21	4042H	Average calculation method (0-1: 0-Linear, 1-Exp)	int32	1	2	Write only	
22	4043H	Total number of mean calculation (0-3: 0-8, 1-16, 2-32, 3-64)	int32	1	2	Write only	
23	4044H	MAXHOLD (0-1: 0-OFF, 1-ON)	int32	1	2	Write only	
24	4045H	HOLD (0-1: 0-OFF, 1-ON)	int32	1	2	Write only	
25	4046H	THD mode (0-1: 0-IEC, 1-CSA)	int32	1	2	Write only	
26	4047H	Maximum number of THD calculations (0-100)	int32	1	2	Write only	
27	4048H	Peak factor(Range 0-1,0-3,1-4)	int32	1	2	Write only	
28	4049H	Harmonic switch (range 0-1,0- off, 1- on)	int32	1	2	Write only	

### Setting class (read only)

No.	Register address Hex.	Data description	Data Format	Register Number	Number of bytes	Remarks	Remark
-----	-----------------------	------------------	-------------	-----------------	-----------------	---------	--------

## Section 6 Appendix to Protocol

1	5000H	Integration time (minute: 0-2880, 48 hours)	Float 32	2	4	Read only
2	5002H	Integral state (6 channels controlled simultaneously) (0-2: 0-Clear, 1-Start, 2-Stop)	Float 32	2	4	Read only
3	5004H	First set load type (range: 0-4, 0-1P2W,1-1P3W, 2-3P3W, 3-3P4W, 4-3V3A)	Float 32	2	4	Read only
4	5006H	First set load type (range: 0-4, 0-1P2W,1-1P3W, 2-3P3W, 3-3P4W, 4-3V3A)	Float 32	2	4	Read only
5	5008H	Calculation cycle (0-6: 0-0.1s, 1-0.2s, 2-0.5s, 3-1s, 4-2s, 5-5s, 6-10s)	Float 32	2	4	Read only
6	500AH	Synchronous measure master/slave selection (0-1: 0-Master, 1-Slave)	Float 32	2	4	Read only
7	500CH	Channel 1 voltage range (0-7: 8 ranges of voltage (more than 7 means auto range). 0—15V, 1—30 V, 2—60 V, 3—100 V, 4—150 V, 5—300 V, 6— 600 V, 7—1000 V)	Float 32	2	4	Read only
	~					
	5012H	Channel 4 voltage range (0-7: 8 ranges of voltage (more than 7 means auto range). 0—15V, 1—30 V, 2—60 V, 3—100 V, 4—150 V, 5—300 V, 6—600 V, 7—1000 V)	Float 32	2	4	Read only
8	5018H	Channel 1 current range (0-7: 8 ranges of current (more than 7 means auto range).)	Float 32	2	4	Read only
	~					
	501EH	Channel 4 current range (0-7: 8 ranges of current (more than 7 means auto range).)	Float 32	2	4	Read only
9	5024H	Channel 1 current source (0-1: 0-BNC input, 1-Direct input)	Float 32	2	4	Read only
	~					
	502AH	Channel 4 current source (0-1: 0-BNC input, 1-Direct input)	Float 32	2	4	Read only
10	5030H	Channel 1 simultaneous source (0-9: 0-U1, 1-I1.....6—U4, 7—I4, 8-EXT,9-NULL)	Float 32	2	4	Read only
	~					
	5036H	Channel 4 simultaneous source (0-9: 0-U1, 1-I1.....6—U4, 7—I4, 8-EXT,9-NULL)	Float 32	2	4	Read only
11	503CH	First set harmonic source ((0-7: 0-U1, 1-I1, ... ,6-U4,7-I4)	Float 32	2	4	Read only
	503EH	First set harmonic source ((0-7: 0-U1, 1-I1, ... ,6-U4,7-I4)	Float 32	2	4	Read only
12	5040H	Group 1 harmonic ON/OFF (0-1: 0-OFF (normal measurement), 1-ON (harmonic measurement))	Float 32	2	4	Read only
	5042H	Group 2 harmonic ON/OFF (0-1: 0-OFF (normal measurement), 1-ON (harmonic measurement))	Float 32	2	4	Read only
13	5044H	Channel 1 FREQ filter (0-1: 0-OFF, 1-ON)	Float 32	2	4	Read only
	~					
	504AH	Channel 4 FREQ filter (0-1: 0-OFF, 1-ON)	Float 32	2	4	Read only
14	5050H	Channel 1 LINE filter (0-1: 0-OFF, 1-500Hz, 2-5.5kHz)	Float 32	2	4	Read only

## Section 6 Appendix to Protocol

	~					
	5056H	Channel 4 LINE filter (0-1: 0-OFF, 1-500Hz, 2-5.5kHz)	Float 32	2	4	Read only
15	505CH	Channel 1 voltage ratio (1.0-50000.0)	Float 32	2	4	Read only
	~					
	5062H	Channel 4 voltage ratio (1.0-50000.0)	Float 32	2	4	Read only
16	5068H	Channel 1 current ratio (1.0~50000.0)	Float 32	2	4	Read only
	~					
	506EH	Channel 4 current ratio (1.0~50000.0)	Float 32	2	4	Read only
17	5074H	Channel 1 BNC ratio (0.01~100.00)	Float 32	2	4	Read only
	~					
	507AH	Channel 4 BNC ratio (0.01~100.00)	Float 32	2	4	Read only
18	5080H	Average state (0-1: 0-OFF, 1-ON)	Float 32	2	4	Read only
19	5082H	Mean calculation method (0-1: 0-Linear, 1-Exp)	Float 32	2	4	Read only
20	5084H	Total number of mean calculation (0-3: 0-8, 1-16, 2-32, 3-64)				
21	5086H	MAXHOLD (0-1: 0-OFF, 1-ON)	Float 32	2	4	Read only
22	5088H	HOLD (0-1: 0-OFF, 1-ON)	Float 32	2	4	Read only
23	508AH	THD mode (0-1: 0-IEC, 1-CSA)	Float 32	2	4	Read only
24	508CH	Maximum number of THD calculations (0-100)	Float 32	2	4	Read only
25	508EH	Peak factor(Range 0-1,0-3,1-4)	Float 32	2	4	Read only

### 2.3 Example of communication data (all data below are in hex)

(1) Set type of load for Channel 1, 2, 3

Send by master: set to 1P3W

0001H	0000H	0006H	01H	06H	40H	01H	00H	00H
Transaction identifier	Modbus Protocol	Data frame length	Instrument address	Comm and	High/low bytes of start register address		2-byte data bit	

(2) Set voltage range (Channel 1)

Send by master: set to 30V

0001H	0000H	0006H	01H	06H	40H	04H	00H	01H
Transaction identifier	Modbus Protocol	Data frame length	Instrument address	Comm and	High/low bytes of start register address		2-byte data bit	

## Section 7 Maintenance

### I. Maintenance and Care

#### 1. Regular Maintenance

- ◆ Check the analyzer, power line, communication line and accessories every year at least, to ensure safety of operators and accuracy of the instrument. If the analyzer works in production place or other severe environment, check them carefully every half year.
- ◆ Power on at regular basis (every month in general) for at least 30 Min. to ensure accuracy after long time storage of the analyzer.
- ◆ Calibrate the instrument every year or more frequent to guarantee accuracy and reliability.

#### 2. Daily Maintenance

- ◆ Never keep the analyzer operates over-range for long time. The allowed amplitude of impact signal shall not exceed 1.6 times of normal signal. If the analyzer is not used, pull off the power line.
- ◆ Keep the analyzer in dry place free of dust or serious vibration for long time storage.
- ◆ Warm up for 30 Min. before using the analyzer after long term storage.

### II. Troubleshooting



**Warning**

**Analysis meter must be repaired or maintained by an experienced professional. Otherwise, personnel injury or death may occur.**

Faults	Measures
There is no display after the analyzer is turned on	1) Check connection of power line; 2) Check the fuse. Any blown one shall be replaced with one of same size; 3) Re-start.
The current/power is zero during normal measuring	1) Check the load; 2) Check the wiring.
Large error between the measurement and the actual value	1) Check the load; 2) Check settings of voltage/current transformer ratio; 3) Check the wiring of load.

April. 2024

V1.0