

Little Giant[®]

Ladder Systems



**PRO
CATALOG
2020**

SKOMBO

PREVENTING INJURIES, SAVING LIVES.™

Hal & Brigitte Wing built their company
on a strong foundation.

EVERY RUNG,
EVERY RIVET,
EVERY WELD MATTERS.
EVERY PERSON MATTERS.

This principle is the reason Little Giant
continues to innovate and improve
climbing equipment today.

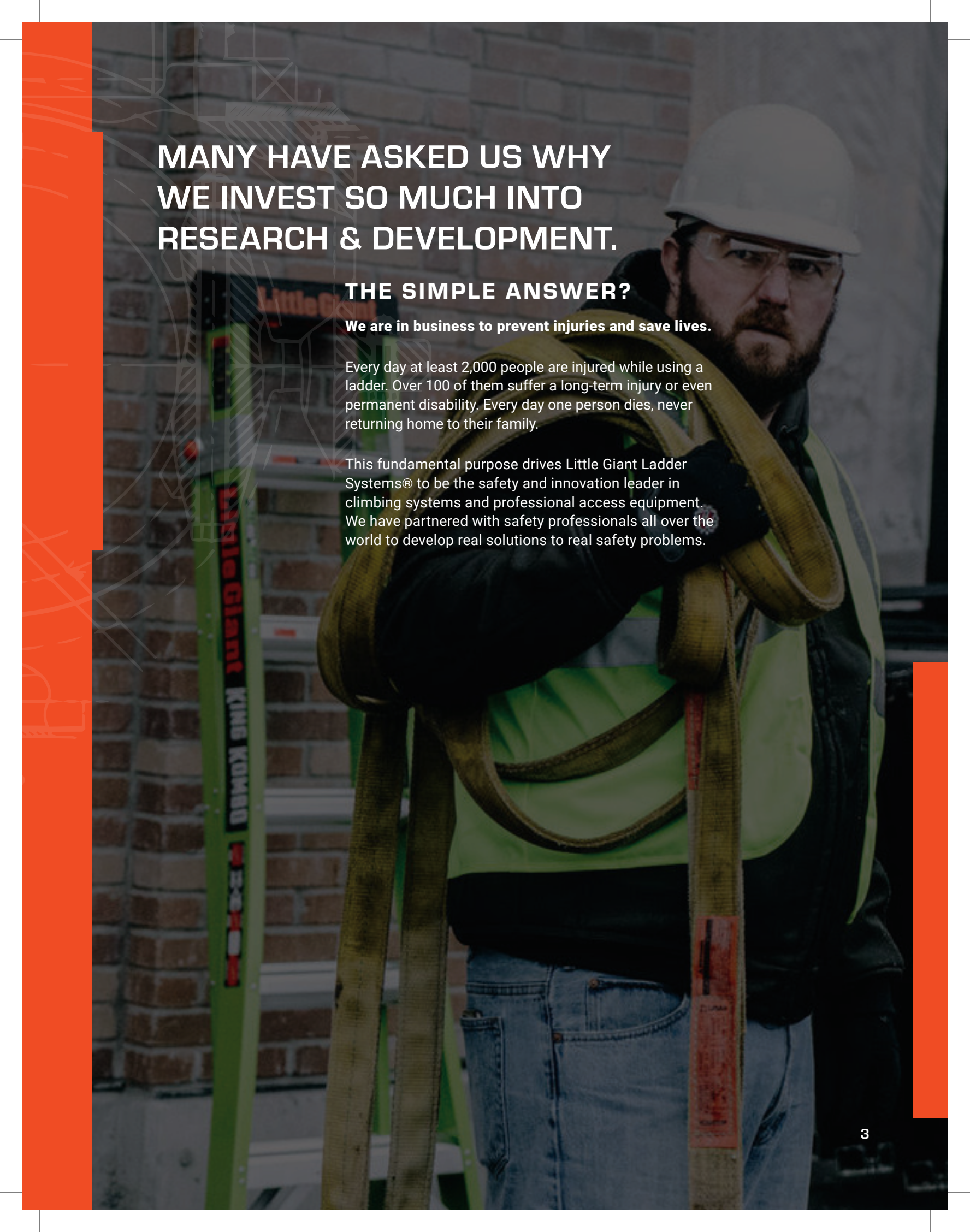

MANY HAVE ASKED US WHY WE INVEST SO MUCH INTO RESEARCH & DEVELOPMENT.

THE SIMPLE ANSWER?

We are in business to prevent injuries and save lives.

Every day at least 2,000 people are injured while using a ladder. Over 100 of them suffer a long-term injury or even permanent disability. Every day one person dies, never returning home to their family.

This fundamental purpose drives Little Giant Ladder Systems® to be the safety and innovation leader in climbing systems and professional access equipment. We have partnered with safety professionals all over the world to develop real solutions to real safety problems.

THE EVERYDAY KILLER

Even the simplest, everyday tool can be deadly when we misuse it. No sane person would swim unprotected in shark-infested waters, walk alone in tiger country or use a chainsaw carelessly. What would you say if we told you there is a seemingly harmless everyday tool that causes more deaths than sharks, tigers, chainsaws and even plane crashes combined – ladders.

We use ladders every day and we often forget about the risks involved and instead worry about shark attacks, plane crashes, lightning strikes or even a hurricane. Remember, at least one person dies every day while using a ladder. Over 400 last year.

THE ONLY ACCEPTABLE NUMBER IS 0.

**“LITTLE GIANT - THE SAFEST, STRONGEST,
MOST VERSATILE LADDERS IN THE WORLD.”**

TIGERS
85

HURRICANES
17



PLANE CRASHES

271

HELICOPTER

65

SPIDER

50

SHARKS

7.6

LADDERS

400+

DEATHS
PER
YEAR

CHAINSAW

1

DOG BITES

31

21

FAULTY
PARACHUTE

LIGHTNING

40-50

THE FUTURE OF CLIMBING EQUIPMENT

Little Giant has taken the next step in climbing equipment safety by creating products engineered to protect you. We design specifically to account for human behavior. Your safety is our obsession.

Our long-held manufacturing creed sums up our commitment to provide the safest access equipment in the world – every weld, every rivet, every rung and every person matters.



DESIGNING FOR HUMAN BEHAVIOR

Although training is extremely important, training alone is not enough to keep you safe. Our new, professional climbing equipment is specifically designed to help you avoid OSHA safety citations as well as injury.

TOP 3 CAUSES OF LADDER ACCIDENTS

1. REPEATED HANDLING OF HEAVY, OUTDATED LADDERS
2. USING THE WRONG LADDER FOR THE JOB; USING THE RIGHT LADDER THE WRONG WAY
3. OVERREACHING

Little Giant is dedicated to leading the industry by constantly striving to help prevent ladder injuries. We design products to stack the cards in your favor, keeping you as safe as possible.

IT IS BETTER TO BUILD A FENCE AT THE TOP OF A CLIFF
THAN TO PARK AN AMBULANCE AT THE BOTTOM.

1. ROTATING WALL PAD

Four positions to help you conquer any challenge. Inside corners, outside corners, walls and 2x4 studs.

2. COMFORT STEPS

Wide steps provide stability and comfort for long hours of getting the job done.

3. GROUND CUE®

Audible "click" on bottom step alerts you when you have reached the bottom step of the ladder.

4. RAIL GUARD

Shock-absorbing braces increase ladder lifespan by protecting it during daily use.

5. NON-CONDUCTIVE RAILS

Non-conductive fiberglass rails rated to hold up to 375 lbs.

6. STRAIGHT-LINE REAR SECTION

Access tight workspaces between wall studs, ceiling trusses and roof or attic access ports.

7. V-BAR

Non-marring, heavy duty stud gripper conforms to outside corners and small poles.

8. NON-MARRING WALL PAD FEET

While in extension configuration, helps protect paint, sheet rock and wall surfaces.

ROTATING WALL PAD



WALL

STUD

INSIDE CORNER

OUTSIDE CORNER



KING KOMBO™



LIGHTWEIGHT



375 LBS RATED



COMBINATION LADDER

STEP
LADDERS

STEP
STOOLS

EXTENSION
LADDERS

MULTI-PURPOSE
LADDERS

CAGES

PRODUCT
SPECS



LEANING

STEPLADDER

EXTENSION



SENTINEL™



COMBINATION LADDER



375 LBS RATED



LIGHTWEIGHT

Sometimes, you need to get closer to the task at hand than a standard stepladder offers, and that's where the Sentinel™ comes in. The Little Giant® Sentinel combines two ladders in one, stepladder and leaning ladder, making it a versatile tool to help you get stuff done with confidence. The Sentinel is available in 10' and 12' models and meets or exceeds all OSHA and ANSI standards.

ROTATING WALL PAD



WALL

STUD

INSIDE
CORNER

OUTSIDE CORNER

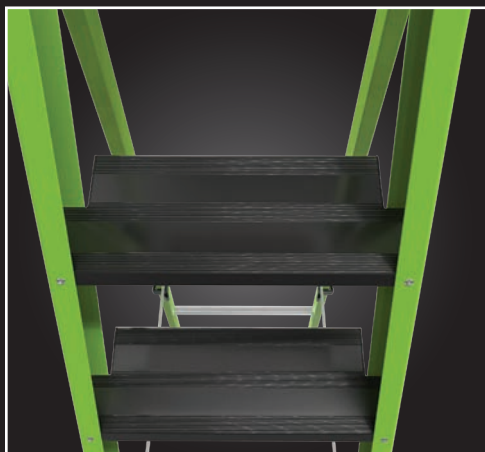

COMFORT STEPS

Wide steps provide stability and comfort for long hours of getting the job done.



1. ROTATING WALL PAD

Four positions to help you conquer any challenge. Inside corners, outside corners, walls and 2x4 studs.



2. EXTRA WIDE COMFORT STEPS

Wide steps provide stability and comfort to prevent fatigue while getting the job done.



3. GROUND CUE®

Audible “click” on bottom step alerts you when you have reached the bottom step of the ladder.



4. RAIL STORAGE LOCKS

Keep rails together while in leaning position, storage and transit.



5. NON-CONDUCTIVE FIBERGLASS RAILS

Non-conductive fiberglass rails rated to hold up to 375 lbs.

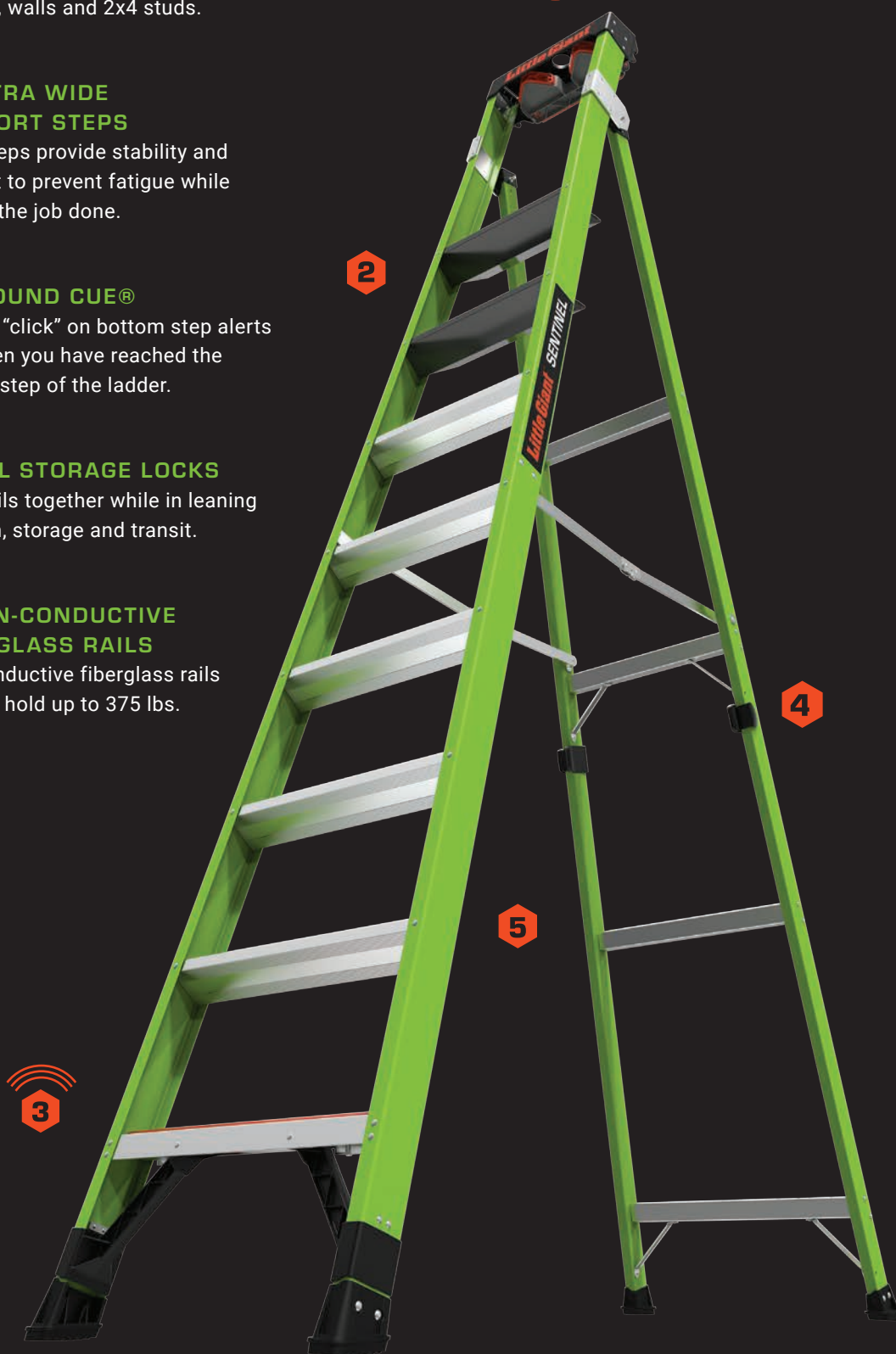

1. TOOL TRAY TOP CAP

Innovative top cap has a place for everything.

2. COMFORT PLATFORM

Stand on the comfort platform for a more balanced and enjoyable working experience.

3. GROUND CUE®

Audible “click” on bottom step alerts you when you have reached the bottom step of the ladder.

4. SLIM STORAGE PROFILE

With a storage profile of only 4”, easily store your MightyLite anywhere.

5. RAIL GUARD

Shock-absorbing braces increase ladder’s lifespan by protecting it during daily use.

6. NON-CONDUCTIVE FIBERGLASS RAILS

Non-conductive fiberglass rails rated to hold up to 375 lbs.



MIGHTYLITE™



LIGHTWEIGHT



300, 375 LBS RATED

Everyone needs an ultra-functional stepladder. If you are looking for a lightweight, comfortable-to-use stepladder that helps you safely reach those high places, the MightyLite™ is the right ladder for the job. The MightyLite meets or exceeds all OSHA and ANSI standards. The 4', 5', 6' and 8' models are available in IA and IAA ratings.

STEP
LADDERS

STEP
STOOLS

EXTENSION
LADDERS

MULTI-PURPOSE
LADDERS

CAGES

PRODUCT
SPECS

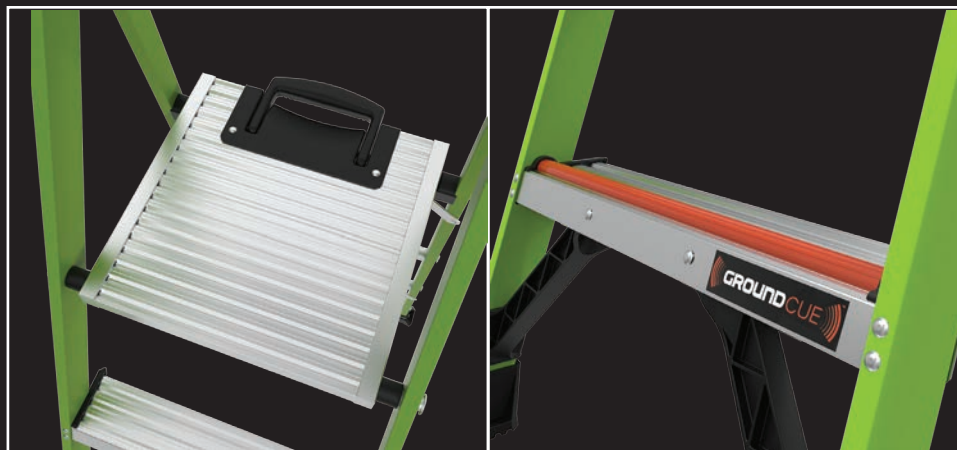

COMFORT PLATFORM

Stand on the comfort platform for a more balanced and safe working experience.

GROUND CUE®

Audible "click" on bottom step alerts you when you have reached the bottom step of the ladder.



DS-XL™



375 LBS RATED



2 PERSON LADDER

The DS-XL™ is designed as a true two-person stepladder. With its wide steps, both users will feel comfortable while working on the ladder. Made with Hi-Viz Green fiberglass, the ladder is non-conductive, and the color promotes safety, as it is the most visible color to the human eye. The DS-XL meets or exceeds all OSHA and ANSI standards, and with a Type IAA rating, it is certified to hold 375 lbs. on both sides. It is available in 6' and 8' models.



RUBBER IMPACT BUMPERS

Rubber bumpers protect ladder and equipment in the event of tipping during transit.

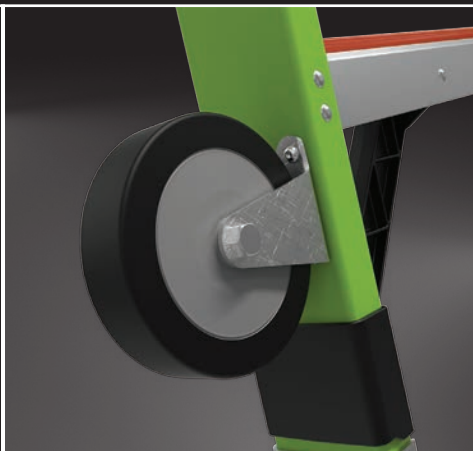

TIP & GLIDE™ WHEELS

Easily move the ladder across the job site with Tip & Glide™ wheels.



1. RUBBER IMPACT BUMPERS

Rubber bumpers protect your ladder and equipment in the event of tipping during transit.

2. DUAL GROUND CUE®

Audible “click” on bottom step alerts you when you have reached the bottom step of the ladder

3. EXTRA WIDE STEPS

Safe and stable comfort steps lessen fatigue during ladder usage.

4. TIP & GLIDE™ WHEELS

Easily move the ladder across the job site with Tip & Glide™ wheels.

5. LONG LIFE FEET

The ladder’s heavy-duty feet are built to last, providing a secure foundation you can count on.

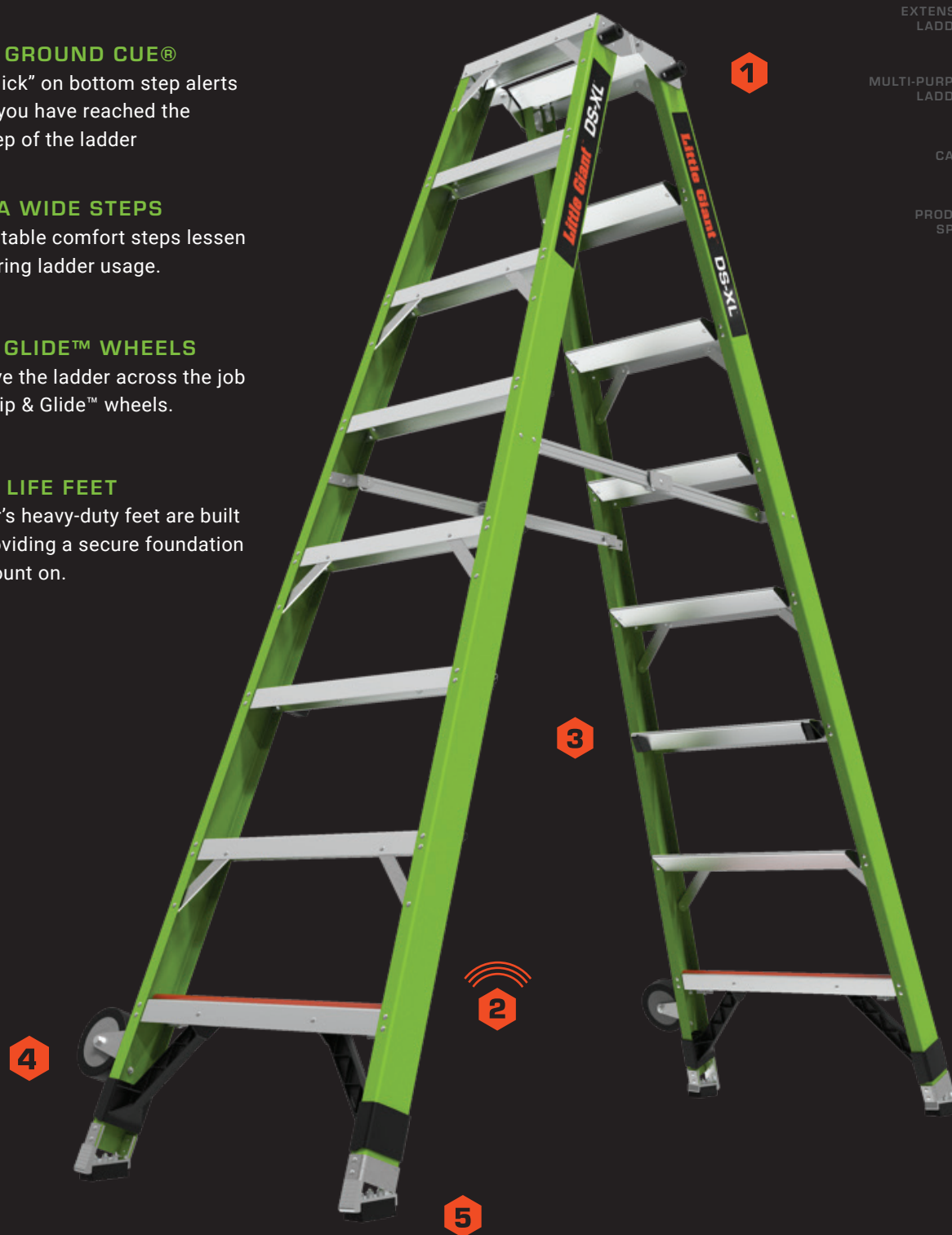

1. ACCESSORY PORTS ON TOP CAP

Ports allow use of Little Giant AirDeck® accessory.

2. WIDE RUNGS

Feel secure and comfortable while standing on your ladder.

3. TIP & GLIDE™ WHEELS

Easily move the ladder across the job site with Tip & Glide™ wheels.

4. ADJUSTABLE HEIGHT

Raise and lower your ladder to work at varying heights or on stairs.

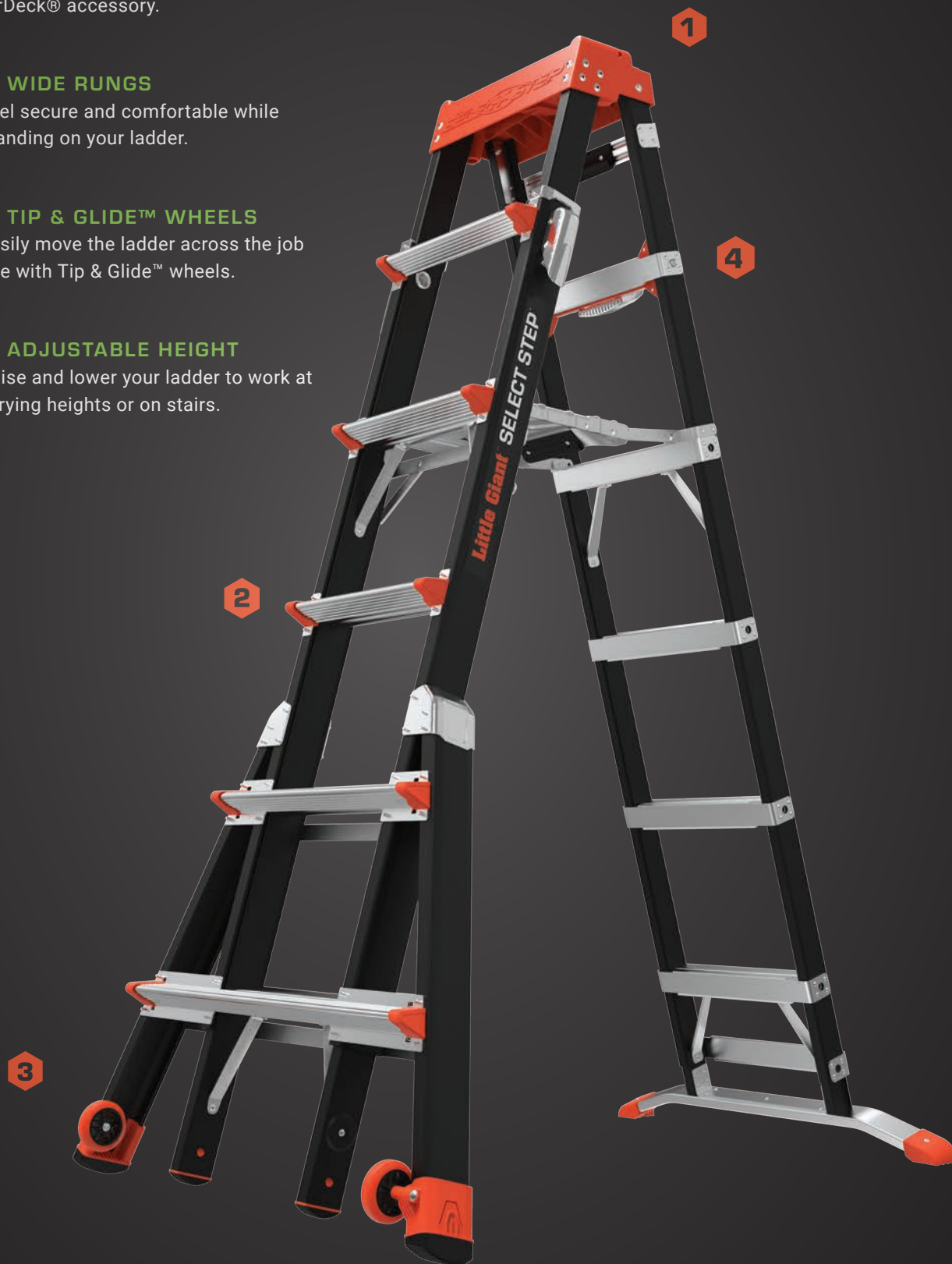

FIBERGLASS

SELECT STEP®



MULTI-POSITION LADDER



375 LBS RATED

Before the Select Step® from Little Giant®, climbing a stepladder was a less than enjoyable experience. Now, you can feel secure and at-ease while climbing and working. Featuring a comfortable standing platform, you will be able to work for long periods atop the Select Step. The Select Step meets or exceeds all OSHA and ANSI standards.

STEP
LADDERS

STEP
STOOLS

EXTENSION
LADDERS

MULTI-PURPOSE
LADDERS

CAGES

PRODUCT
SPECS



ADJUSTABILITY

Easily adjusts to multiple configurations. Stepladder, 90°, Sloping Ground. No Job is out of reach.

ACCESSORY PORTS

Ports allow use of Little Giant AirDeck® accessory in vertical and horizontal positions.



JUMBO STEP™



LIGHTWEIGHT



375 LBS RATED

Not all tasks require a full-sized ladder, and that is where the Jumbo Step™ from Little Giant® comes in. The Jumbo Step is a lightweight aluminum step stool, and with its compact design, it is the perfect tool for small-scale or at-home projects. Available in 2, 3 and 4-step models, this ladder meets or exceeds all OSHA and ANSI standards.



TOOL TRAY TOP CAP

Place your phone, hammer, drill or other materials on the tray for easy access while working.



WIDE, SLIP-RESISTANT COMFORT STEPS

Each step's treads are slip-resistant for extra security.



STEP
LADDERS

STEP
STOOLS

EXTENSION
LADDERS

MULTI-PURPOSE
LADDERS

CAGES

PRODUCT
SPECS

1. SAFETY HANDRAIL

With the rotating handrail, you will feel stable while working on the Jumbo Step.

2. TOOL TRAY TOP CAP

Place your phone, hammer, drill or other materials on the tray for easy access while working.

3. SLIP-RESISTANT STEPS

Each step's treads are slip-resistant for extra security.

4. WIDE COMFORT STEPS

With its ultra-wide steps, it feels like walking up a staircase, not a ladder.

5. LIGHT, YET RATED FOR 375 LBS

Lightweight aluminum holds more than most traditional stepstools.

6. WIDE-FLARED FEET

The Jumbo Step's extra-wide, slip resistant feet are perfect for working over grates.



1. DOUBLE-PULLEY SYSTEM

By moving the pulley to the side of the ladder, the rope stays away from your feet. Incorporating a double-pulley makes adjusting the ladder easy and simple.

2. BUBBLE LEVELS

With bubble levels, you will always know if your ladder is level before you begin climbing.

3. SURE-SET™ FEET

Securely stays in place, swivels for use in the spike foot position.

4. CLAW® FASTENING SYSTEM

Optional add-on: Clamp the ladder to an anchor point.

5. LIGHTWEIGHT FIBERGLASS

Lightweight, non-conductive fiberglass rails rated to hold up to 375 lbs.

6. HI-VIZ GREEN

Easily visible, this Hi-Viz green color increases ladder visibility and safety.



HYPERLITE®



LIGHTWEIGHT



300, 375 LBS RATED

Using an extension ladder can be intimidating, but with the right ladder, it doesn't have to be. The Little Giant® HyperLite® is ultra-light and designed with safety and ease of use in mind, so you can focus on the task-at-hand, rather than worrying about your ladder. The HyperLite is available in IA and IAA ratings. For rating sizes see page 37.

STEP
LADDERS

STEP
STOOLS

EXTENSION
LADDERS

MULTI-PURPOSE
LADDERS

CAGES

PRODUCT
SPECS



CLAW® FASTENING SYSTEM

Optional add-on: Clamp the ladder to an anchor point.

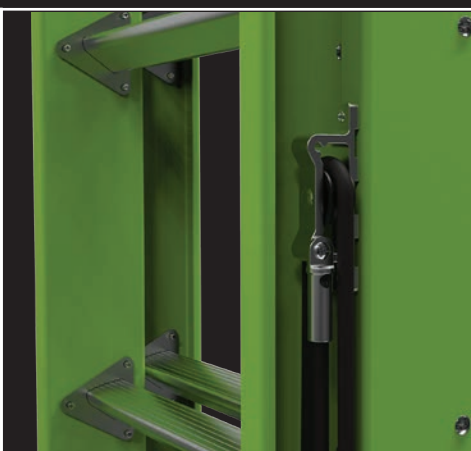

DOUBLE-PULLEY SYSTEM

By moving the pulley to the side of the ladder, and incorporating a double-pulley operation, adjusting the ladder is simple.



SUMOSTANCE[®]



LIGHTWEIGHT



300, 375 LBS RATED

The SumoStance is the only extension ladder in the world with Little Giant's patented SumoStance leveling outrigger system, which more than doubles the ladder's base width and increases side-tip stability. The SumoStance's intuitive safety features help ensure a safe, stable set-up for any job on almost any surface and is lighter than ordinary extension ladders.



WIDE-STANCE LEVELING AND OUTRIGGING

Easily adapt to uneven terrain to feel more secure on your ladder.

BUBBLE LEVELS

With bubble levels on the side and at the base of the bottom rung, you will always know if your ladder is level and safe to climb.



STEP
LADDERS

STEP
STOOLS

EXTENSION
LADDERS

MULTI-PURPOSE
LADDERS

CAGES

PRODUCT
SPECS

1. WIDE-STANCE LEVELERS

Easily adapt to uneven terrain to feel more secure on your ladder.

2. DOUBLE-PULLEY SYSTEM

By moving the pulley to the side of the ladder, the rope stays away from your feet. Incorporating a double-pulley makes adjusting the ladder easy and simple.

3. BUBBLE LEVELS

With bubble levels, you will always know if your ladder is level and at the right angle.

4. SURE-SET™ FEET

Securely stays in place, swivels for use in the spike foot position.

5. LIGHTWEIGHT FIBERGLASS

Lightweight, non-conductive fiberglass rails rated to hold up to 375 lbs.

6. HI-VIZ GREEN

Easily visible, this Hi-Viz green color increases ladder visibility and safety.

7. GROUND CUE®

Audible "click" on bottom rung alerts you when you have reached the bottom rung of the ladder.



1. MULTIPLE CONFIGURATIONS

Extend your ladder's length to meet the job's particular needs.

2. NARROW ACCESS

Narrow ladder allows for easy access to manholes and other tight spaces.

3. RAPID LOCK® FASTENERS

Quickly adjust and securely fasten your ladder.



UNDERGROUND

UTILITY ACCESS™

STEP
LADDERS

STEP
STOOLS

EXTENSION
LADDERS

MULTI-PURPOSE
LADDERS

CAGES

PRODUCT
SPECS



LIGHTWEIGHT



375 LBS RATED

Easily access your tasks at the job site with the Underground Utilities Access™ Ladder. While most manhole ladders are heavy and awkward to carry, the Little Giant® Utility Access Ladder is designed to allow one pro to access underground work areas quickly and safely. With ladder extenders in varying sizes, you can set up your ladder to have the right lengths needed for the task at hand.



TWO TOP SIZES

With two different length-attachable ladder segments, the Utility Access ladder can be configured to reach 12', 16' or 20'.

RAPID LOCKS®

Quickly adjust and fasten your ladder.



DARK HORSE™



MULTI-POSITION LADDER



300, 375 LBS RATED

The Little Giant® Dark Horse™ combines some of our best ladder features into one versatile multi-position ladder that will suit your ladder needs for years to come. Set up the Dark Horse in stepladder, extension, 90-degree, staircase and trestle-and-plank* positions, for a versatile, easy climbing experience. The Dark Horse meets or exceeds all OSHA and ANSI standards.

**Plank accessory not included.*



VERSATILITY

Stepladder, extension, 90° and sloping ground configurations give you the ability to get around any obstacle.



1. WIDE-FLARED BASE

Feels safe with a solid foundation, decreasing the odds of tipping.

2. NON-CONDUCTIVE RAILS

Sturdy, non-conductive fiberglass rails keep you safe while on the job.

3. METAL PALM BUTTONS

Upgraded palm buttons make for an easy transition to other ladder configurations.

4. METAL ROCK LOCK® FASTENERS

Quickly adjust and easily configure your ladder.

STEP
LADDERS

STEP
STOOLS

EXTENSION
LADDERS

MULTI-PURPOSE
LADDERS

CAGES

PRODUCT
SPECS



1. WIDE-FLARED BASE

Feels safe with a solid foundation, increasing side-tip stability.

2. RATCHET™ LEVELERS

Easily adapt to uneven terrain to feel level on your ladder.

3. METAL ROCK LOCKS®

Quickly adjust and configure your ladder.

4. METAL PALM BUTTONS

Upgraded palm buttons make for an easy transition to other ladder configurations.

5. QUAD-LOCK™ HINGE

Quad-Lock hinge is durable, easy to use and is built for professionals.



REVOLUTION™



MULTI-POSITION LADDER



300 LBS RATED

The Little Giant® Revolution™ is a lightweight multi-position ladder with Ratchet™ Levelers to adjust your ladder to meet uneven terrain. Feel secure no matter where the job may take you. The Revolution meets or exceeds all OSHA and ANSI standards.

STEP
LADDERS

STEP
STOOLS

EXTENSION
LADDERS

MULTI-PURPOSE
LADDERS

CAGES

PRODUCT
SPECS



METAL PALM BUTTON

Upgraded palm buttons make for an easy transition to other ladder configurations.



RATCHET LEVELERS

Easily adapt to uneven terrain to feel more secure on your ladder.



CONQUEST™



MULTI-POSITION LADDER



375 LBS RATED



CARRYING HANDLE

Attached carrying handle improves ladder portability.



V-BAR

Optional add on: Non-marring, heavy duty v-bar grips poles and conforms to outside corners.



1. CARRYING HANDLE

Attached carrying handle improves ladder portability.

2. NARROW ACCESS

Narrow ladder allows for easy access to tight spaces.

3. NON-CONDUCTIVE FIBERGLASS

Non-conductive fiberglass rails rated to hold up to 375 lbs.

4. METAL PALM BUTTONS

Upgraded palm buttons make for an easy transition to other ladder configurations.

5. METAL ROCK LOCK® FASTENERS

Quickly adjust and configure your ladder.

6. V-BAR

Non-marring, heavy duty v-bar grips poles and conforms to outside corners.

7. WIDE-FLARED BASE

Feel safe with a solid foundation, increasing side-tip stability.

STEP
LADDERS

STEP
STOOLS

EXTENSION
LADDERS

MULTI-PURPOSE
LADDERS

CAGES

PRODUCT
SPECS



1. FULLY ENCLOSED PLATFORM

42" handrail plus midspan and toe kick can eliminate the need to tie off in most situations. Enclosed platform promotes comfort while elevated.

2. GROUND CUE®

Audible "click" on bottom step alerts you when you have reached the bottom.

3. NON-CONDUCTIVE FIBERGLASS

Non-conductive fiberglass rails rated to hold up to 375 lbs.



SAFETY CAGE®



375 LBS RATED

Designed for ultimate safety while working elevated, the Safety Cage® eliminates the need for scaffolding or tying off. The non-conductive fiberglass cage is fully enclosed and is OSHA and ANSI compliant. The one-way self closing gates keep you securely enclosed while working.

STEP
LADDERS

STEP
STOOLS

EXTENSION
LADDERS

MULTI-PURPOSE
LADDERS

CAGES

PRODUCT
SPECS



ENCLOSURE

Self-closing, one-way gates designed with ultimate safety in mind.

PLATFORM

Safely and comfortably work up high in an enclosed platform.



ADJUSTABLE

SAFETY CAGE®



375 LBS RATED

Many industries require professionals to tie off at an anchor point when working at certain heights. This standard helps keep people safe, but it can be a difficult standard to maintain. The OSHA-compliant Little Giant® Adjustable Safety Cage® replaces portable scaffolding and scissor lifts and eliminates the need to tie-off, making jobs faster, safer and less expensive. The Adjustable Safety Cage meets or exceeds all OSHA and ANSI standards and is rated IAA to hold 375 lbs.



DEPLOYABLE OUTRIGGERS

Additional stability with deployable outriggers.

WHEEL LIFT™ CASTERS

Easily move the Cage while fully deployed.



STEP
LADDERS

STEP
STOOLS

EXTENSION
LADDERS

MULTI-PURPOSE
LADDERS

CAGES

PRODUCT
SPECS

1. FULLY ENCLOSED PLATFORM

Safely work up high in an enclosed platform.

2. WHEEL LIFT™ CASTERS

Easily move the Cage while fully deployed.

3. TIP & GLIDE™ WHEELS

Easily move the Cage across the job site with Tip & Glide™ wheels.

4. DEPLOYABLE OUTRIGGERS

Additional stability with deployable outriggers.

5. NON-CONDUCTIVE FIBERGLASS

Non-conductive fiberglass rails rated to hold up to 375 lbs.

6. WIDE-FLARED BASE

Prevent incidents with a solid foundation, increasing side-tip stability.



PRODUCT SPECS

All of the ladders and accessories from Little Giant Ladders® are OSHA and ANSI compliant, meeting or exceeding all of the organizations' standards. Below, you can find all of the products shown in the previous pages with their respective specifications. The page numbers for the products are listed next to the product name. If you have additional questions, please contact the Little Giant Customer Experience team at 800-453-1192.

KING KOMBO PAGE 8

PART NUMBER	MODEL	STEPLADDER HIGHEST STANDING LEVEL	STEPLADDER MAX REACH*	EXTENSION HIGHEST STANDING LEVEL	EXTENSION MAX REACH*	SPREAD	STORAGE WIDTH	STORAGE DEPTH	WEIGHT
13610-071	6'-10'	3' 9"	10' 3"	6' 9"	12' 8"	3' 8"	2' .5"	6.5"	24 lbs
13712-074	7'-12'	4' 8"	11' 2"	8' 9"	15' 3"	4' 7"	2' 4.5"	6.5"	28 lbs
13814-071	8'-14'	5' 8"	12' 2"	10' 7"	17' 1"	5' 3"	2' 4"	6.5"	32 lbs

* A 5' 6" PERSON WITH A 12" VERTICAL REACH
7'-12" MODEL INCLUDES SURE-SET™ FEET

SENTINEL PAGE 10

PART NUMBER	MODEL	STEPLADDER HIGHEST STANDING LEVEL	STEPLADDER MAX REACH*	SPREAD	STORAGE WIDTH	STORAGE DEPTH	WEIGHT
15910-001	10	7' 8"	14' 2"	5' 4"	2' 2"	7"	40 lbs
15912-001	12	9' 7"	16' 1"	6' 3"	2' 4"	7"	48 lbs

* A 5' 6" PERSON WITH A 12" VERTICAL REACH

MIGHTYLITE PAGE 12

PART NUMBER	MODEL	RATING	HIGHEST STANDING LEVEL	MAX REACH*	SPREAD	STEP DEPTH	STORAGE HEIGHT	STORAGE WIDTH	STORAGE DEPTH	WEIGHT
15364-001	4' (2 step)	1A	1' 10.5"	8' 4.5"	2' 3.5"	3.25"	4' 2"	1' 7"	4"	12 lbs
15384-001	4' (2 step)	1AA	1' 10.5"	8' 4.5"	2' 3.5"	3.25"	4' 2"	1' 7"	4"	13 lbs
15365-001	5' (3 step)	1A	2' 10"	9' 4"	2' 11"	3.25"	5' 2"	1' 8.5"	4"	14 lbs
15385-001	5' (3 step)	1AA	2' 10"	9' 4"	2' 11"	3.25"	5' 2"	1' 8.5"	4"	16 lbs
15366-001	6' (4 step)	1A	3' 9.5"	10' 3.5"	3' 7"	3.25"	6' 2"	1' 10"	4"	17 lbs
15386-001	6' (4 step)	1AA	3' 9.5"	10' 3.5"	3' 7"	3.25"	6' 2"	1' 10"	4"	19 lbs
15368-001	8' (6 step)	1A	5' 8"	12' 2"	4' 11"	3.25"	8' 2"	2'	4"	24 lbs
15388-001	8' (6 step)	1AA	5' 8"	12' 2"	4' 11"	3.25"	8' 2"	2'	4"	25 lbs

* A 5' 6" PERSON WITH A 12" VERTICAL REACH
COMFORT PLATFORM 13" X 13"

DS-XL PAGE 14

PART NUMBER	MODEL	STEPLADDER HIGHEST STANDING LEVEL MIN-MAX	MAX REACH*	SPREAD	STORAGE HEIGHT	STORAGE DEPTH	WEIGHT
15786-001	6	3' 9.5"	10' 3.5"	5'	6' 2"	10.5"	35.5 lbs
15788-001	8	5' 8"	12' 2"	6' 5"	8' 2"	10.5"	47 lbs

* A 5' 6" PERSON WITH A 12" VERTICAL REACH

SELECT STEP PAGE 16

PART NUMBER	MODEL	STEPLADDER HIGHEST STANDING LEVEL MIN-MAX	MAX REACH*	SPREAD MIN-MAX	STORAGE HEIGHT	STORAGE DEPTH	WEIGHT
15130-001	5' - 8'	2' 10" - 5' 8"	12' 4"	3' 5" - 5' 2.5"	5' 1.5"	8.5"	34 lbs
15131-001	6' - 10'	3' 10" - 7' 7"	14' 1"	4' - 6' 5"	6' 1"	9"	41 lbs

* A 5' 6" PERSON WITH A 12" VERTICAL REACH
COMFORT STEP 12" X 10"

STEP
LADDERS

STEP
STOOLS

EXTENSION
LADDERS

MULTI-PURPOSE
LADDERS

JUMBO STEP PAGE 18

PART NUMBER	MODEL	STEP STOOL SIZE	STEP STOOL MAX REACH*	HIGHEST STANDING LEVEL	STEP WIDTH	STORAGE DEPTH	WEIGHT
11902	2 Step	2'	8'	1' 6"	8.5"	4.5"	11.9 lbs
11903	3 Step	3'	8' 8"	2' 2"	8.5"	4.5"	16 lbs
11904	4 Step	4'	9' 5"	2' 11"	8.5"	4.5"	20 lbs

* A 5' 6" PERSON WITH A 12" VERTICAL REACH

CAGES

PRODUCT
SPECS

HYPERLITE PAGE 20

PART NUMBER	MODEL	HIGHEST STANDING LEVEL	MAX REACH*	TRIANGLE RUNG DEPTH	STORAGE HEIGHT	STORAGE WIDTH	WEIGHT
18716	16' Type 1A	9' 5"	15' 11"	1.5"	8' 8"	1' 5.5"	31 lbs
18316	16' Type 1A Claw, Cable Hooks & Pole Strap**	9' 5"	15' 11"	1.5"	8' 8"	1' 5.5"	37 lbs
17916	16' Type 1AA	9' 5"	15' 11"	1.5"	8' 8"	1' 5.5"	31 lbs
17516	16' Type 1AA Claw, Cable Hooks & Pole Strap**	9' 5"	15' 11"	1.5"	8' 8"	1' 5.5"	37 lbs
18720	20' Type 1A	13' 3"	19' 9"	1.5"	10' 7"	1' 5.5"	39 lbs
18320	20' Type 1A Claw, Cable Hooks & Pole Strap**	13' 3"	19' 9"	1.5"	10' 7"	1' 5.5"	44 lbs
17920	20' Type 1AA	13' 3"	19' 9"	1.5"	10' 7"	1' 5.5"	39 lbs
17520	20' Type 1AA Claw, Cable Hooks & Pole Strap**	13' 3"	19' 9"	1.5"	10' 7"	1' 5.5"	44 lbs
18724	24' Type 1A	17' 1"	23' 7"	1.5"	12' 6.5"	1' 5.5"	45 lbs
18324	24' Type 1A Claw, Cable Hooks & Pole Strap**	17' 1"	23' 7"	1.5"	12' 6.5"	1' 5.5"	49 lbs
17924	24' Type 1AA	17' 1"	23' 7"	1.5"	12' 6.5"	1' 5.5"	45 lbs
17524	24' Type 1AA Claw, Cable Hooks & Pole Strap**	17' 1"	23' 7"	1.5"	12' 6.5"	1' 5.5"	49 lbs
18728	28' Type 1A	20' 11"	27' 5"	1.5"	14' 6.5"	1' 5.5"	52 lbs
18328	28' Type 1A Claw, Cable Hooks & Pole Strap**	20' 11"	27' 5"	1.5"	14' 6.5"	1' 5.5"	55 lbs
17928	28' Type 1AA	20' 11"	27' 5"	1.5"	14' 6.5"	1' 5.5"	52 lbs
17528	28' Type 1AA Claw, Cable Hooks & Pole Strap**	20' 11"	27' 5"	1.5"	14' 6.5"	1' 5.5"	55 lbs
18732	32' Type 1A	24' 9"	31' 2"	1.5"	16' 6"	1' 5.5"	63 lbs
18332	32' Type 1A Claw, Cable Hooks & Pole Strap**	24' 9"	31' 2"	1.5"	16' 6"	1' 5.5"	69 lbs
17932	32' Type 1AA	24' 9"	31' 2"	1.5"	16' 6"	1' 5.5"	63 lbs
17532	32' Type 1AA Claw, Cable Hooks & Pole Strap**	24' 9"	31' 2"	1.5"	16' 6"	1' 5.5"	69 lbs
17736	36' Type 1A	27' 7"	34' 1"	1.5"	18' 5"	1' 5.5"	70 lbs
17336	36' Type 1A Claw, Cable Hooks & Pole Strap**	27' 7"	34' 1"	1.5"	18' 5"	1' 5.5"	73 lbs
17740	40' Type 1A	30' 5"	36' 11"	1.5"	20' 4.5"	1' 5.5"	77 lbs
17340	40' Type 1A Claw, Cable Hooks & Pole Strap**	30' 5"	36' 11"	1.5"	20' 4.5"	1' 5.5"	80 lbs

* A 5' 6" PERSON WITH A 12" VERTICAL REACH

** ADD V TO THE END OF THE PART NUMBER TO REPLACE THE POLE STRAP WITH A V-BAR
COMPLIES WITH ALL OSHA, ANSI A14 STRENGTH AND TESTING STANDARDS. RUNG/STEP
SPACING COMPLIES TO OSHA AND INT'L STANDARDS. OSHA 1910.23, OSHA 1926.10.53, CSA
Z11, EN131-1, AS/NZS 1892.2.6.2

SUMOSTANCE PAGE 22

PART NUMBER	MODEL	HIGHEST STANDING LEVEL	MAX REACH*	TRIANGLE RUNG DEPTH	STORAGE HEIGHT	STORAGE WIDTH	WEIGHT
18816	16' Type 1A	9' 6"	16'	1.5"	8' 8"	1' 10.5"	41 lbs
18416	16' Type 1A Claw, Cable Hooks & Pole Strap**	9' 6"	16'	1.5"	8' 8"	1' 10.5"	44 lbs
17216	16' Type 1AA	9' 6"	16'	1.5"	8' 8"	1' 10.5"	41 lbs
17616	16' Type 1AA Claw, Cable Hooks & Pole Strap**	9' 6"	16'	1.5"	8' 8"	1' 10.5"	44 lbs
18820	20' Type 1A	13' 4"	19' 10"	1.5"	10' 7"	1' 10.5"	47 lbs
18420	20' Type 1A Claw, Cable Hooks & Pole Strap**	13' 4"	19' 10"	1.5"	10' 7"	1' 10.5"	50 lbs
17220	20' Type 1AA	13' 4"	19' 10"	1.5"	10' 7"	1' 10.5"	47 lbs
17620	20' Type 1AA Claw, Cable Hooks & Pole Strap**	13' 4"	19' 10"	1.5"	10' 7"	1' 10.5"	50 lbs
18824	24' Type 1A	17' 2"	23' 8"	1.5"	12' 6.5"	1' 10.5"	54 lbs
18424	24' Type 1A Claw, Cable Hooks & Pole Strap**	17' 2"	23' 8"	1.5"	12' 6.5"	1' 10.5"	58 lbs
17224	24' Type 1AA	17' 2"	23' 8"	1.5"	12' 6.5"	1' 10.5"	54 lbs
17624	24' Type 1AA Claw, Cable Hooks & Pole Strap**	17' 2"	23' 8"	1.5"	12' 6.5"	1' 10.5"	58 lbs
18828	28' Type 1A	20' 10"	27' 4"	1.5"	14' 6.5"	1' 10.5"	61 lbs
18428	28' Type 1A Claw, Cable Hooks & Pole Strap**	20' 10"	27' 4"	1.5"	14' 6.5"	1' 10.5"	65 lbs
17228	28' Type 1AA	20' 10"	27' 4"	1.5"	14' 6.5"	1' 10.5"	61 lbs
17628	28' Type 1AA Claw, Cable Hooks & Pole Strap**	20' 10"	27' 4"	1.5"	14' 6.5"	1' 10.5"	65 lbs
18832	32' Type 1A	24' 10"	31' 4"	1.5"	16' 6"	1' 10.5"	73 lbs
18432	32' Type 1A Claw, Cable Hooks & Pole Strap**	24' 10"	31' 4"	1.5"	16' 6"	1' 10.5"	76 lbs
17232	32' Type 1AA	24' 10"	31' 4"	1.5"	16' 6"	1' 10.5"	73 lbs
17632	32' Type 1AA Claw, Cable Hooks & Pole Strap**	24' 10"	31' 4"	1.5"	16' 6"	1' 10.5"	76 lbs
17836	36' Type 1A	27' 8"	34' 2"	1.5"	18' 5"	1' 10.5"	74 lbs
17436	36' Type 1A Claw, Cable Hooks & Pole Strap**	27' 8"	34' 2"	1.5"	18' 5"	1' 10.5"	81 lbs
17840	40' Type 1A	30' 6"	37'	1.5"	20' 4.5"	1' 10.5"	81 lbs
17440	40' Type 1A Claw, Cable Hooks & Pole Strap**	30' 6"	37'	1.5"	20' 4.5"	1' 10.5"	89 lbs

* A 5' 6" PERSON WITH A 12" VERTICAL REACH
 ** ADD V TO THE END OF THE PART NUMBER TO REPLACE THE POLE STRAP WITH A V-BAR
 COMPLIES WITH ALL OSHA, ANSI A14 STRENGTH AND TESTING STANDARDS. RUNG/STEP
 SPACING COMPLIES TO OSHA AND INT'L STANDARDS. OSHA 1910.23, OSHA 1926.10.53, CSA
 Z11, EN131-1, AS/NZS 1892.2.6.2

UNDERGROUND UTILITY ACCESS PAGE 24

PART NUMBER	MODEL	HIGHEST STANDING LEVEL	EXTENSION LADDER SIZE	MAX REACH*	TRIANGLE RUNG DEPTH	STORAGE HEIGHT	STORAGE WIDTH	WEIGHT
17012-001	12' Base Section with attachable 4' and 8' Fly	16' 1"	12' - 20'	22' 7"	1.5"	12' 6.5"	1' 2.5"	45 lbs

* A 5' 6" PERSON WITH A 12" VERTICAL REACH
 ** SPECIAL PURPOSE LADDER. COMPLIES WITH ALL OSHA AND ANSI A14 STANDARDS, EXCEPT
 BASE WIDTH AND RUNG SPACING
 17012-001 INCLUDES THE 4' AND 8' SECTIONS

DARK HORSE PAGE 26

PART NUMBER	MODEL	STEPLADDER SIZE MIN-MAX	STEPLADDER HIGHEST STANDING LEVEL MIN-MAX	EXTENSION SIZE MIN-MAX	EXTENSION HIGHEST STANDING LEVEL MIN-MAX	STORAGE HEIGHT	STORAGE DEPTH	WEIGHT
15143-001	13	3' - 5'	1' .5" - 2' 11"	7' - 11'	3' 10" - 7' 9"	3' 7"	10"	35 lbs
15147-001	17	4' - 7'	1' 11.5" - 4' 10"	9' - 15'	5' 9" - 11' 7"	4' 7"	10"	44 lbs
15147-801	17	4' - 7'	1' 11.5" - 4' 10"	9' - 15'	5' 9" - 11' 7"	4' 7"	10"	51 lbs
15145-001	22	5' - 9'	2' 11" - 6' 8"	11' - 19'	7' 10" - 15' 6"	5' 7"	10"	51 lbs
15145-801	22	5' - 9'	2' 11" - 6' 8"	11' - 19'	7' 10" - 15' 6"	5' 7"	10"	60 lbs

-801 INCLUDES RATCHET LEVELERS
 M17 AND M22 TYPE IA 300 LBS RATED
 M13 TYPE IAA 375 LBS RATED

REVOLUTION PAGE 28

PART NUMBER	MODEL	STEPLADDER SIZE MIN-MAX	STEPLADDER HIGHEST STANDING LEVEL MIN-MAX	EXTENSION SIZE MIN-MAX	EXT. HIGHEST STANDING LEVEL MIN-MAX	STORAGE HEIGHT	STORAGE DEPTH	WEIGHT
12017	17	4' - 7'	1' 11" - 4' 10"	9' - 15'	5' 9" - 11' 7"	4' 7"	9"	33 lbs
12017-801	17	4' - 7'	1' 11" - 4' 10"	9' - 15'	5' 9" - 11' 7"	4' 7"	9"	39 lbs
12022	22	5' - 9'	2' 11" - 6' 8"	11' - 19'	7' 10" - 15' 6"	5' 7"	9"	41 lbs
12022-801	22	5' - 9'	2' 11" - 6' 8"	11' - 19'	7' 10" - 15' 6"	5' 7"	9"	47 lbs
12026	26	6' - 11'	3' 10" - 8' 7"	13' - 23'	9' 9" - 19' 4"	6' 7"	9"	52 lbs
12026-801	26	6' - 11'	3' 10" - 8' 7"	13' - 23'	9' 9" - 19' 4"	6' 7"	9"	58 lbs

-801 INCLUDES RATCHET LEVELERS

STEP LADDERS

STEP STOOLS

EXTENSION LADDERS

MULTI-PURPOSE LADDERS

CAGES

PRODUCT SPECS

CONQUEST PAGE 30

PART NUMBER	MODEL	STEPLADDER SIZE MIN-MAX	STEPLADDER HIGHEST STANDING LEVEL MIN-MAX	EXTENSION SIZE MIN-MAX	EXT. HIGHEST STANDING LEVEL MIN-MAX	STORAGE HEIGHT	STORAGE DEPTH	WEIGHT
15144	17	4' - 7'	2' - 4' 10"	9' - 15'	5' 9" - 11' 7"	4' 7"	10"	40 lbs
15144-186*	17	4' - 7'	2' - 4' 10"	9' - 15'	5' 9" - 11' 7"	4' 7"	10"	42 lbs
15146	22	5' - 9'	2' 11" - 6' 8"	11' - 19'	7' 10" - 15' 6"	6' 7"	10"	47 lbs
15146-186*	22	5' - 9'	2' 11" - 6' 8"	11' - 19'	7' 10" - 15' 6"	6' 7"	10"	49 lbs

* INCLUDES V-BAR

SAFETY CAGE PAGE 32

PART NUMBER	MODEL	COMPARABLE STEP LADDER SIZE	HIGHEST STANDING LEVEL	MAX REACH*	SPREAD	STEP DEPTH	STORAGE HEIGHT	STORAGE WIDTH AT BASE	WEIGHT
19602	2'	4'	1' 10"	8' 4"	2' 10.5"	3"	6' 6"	2'	46 lbs
19604	4'	6'	3' 9"	10' 3"	4' 1.5"	3"	8' 6"	2' 5"	54 lbs
19606	6'	8'	5' 8"	12' 2"	5' 4"	3"	10' 6"	2' 9"	67 lbs
19608	8'	10'	7' 6"	14'	6' 7"	3"	12' 6"	3'	77 lbs
19610	10'	12'	9' 5"	15' 11"	7' 11"	3"	14' 7"	3' 3"	90 lbs

* A 5' 6" PERSON WITH A 12" VERTICAL REACH
STORAGE DEPTH: 6" PLATFORM SIZE: 18" X 22" GUARDRAIL HEIGHT: 42"

SAFETY CAGE ADJUSTABLE PAGE 34

PART NUMBER	MODEL	HIGHEST STANDING LEVEL MIN-MAX	MAX REACH*	SPREAD MIN-MAX	STORAGE HEIGHT	WEIGHT
18503-240**	3' - 5'	3' - 4' 11"	11' 5"	3' 9" - 5' 11"	7' 10"	102 lbs
18503-243**	3' - 5'	3' - 4' 11"	11' 5"	3' 9" - 5' 11"	7' 10"	107 lbs
18509-240	5' - 9'	4' 11" - 8' 8.5"	15' 2"	5' - 7' 5"	9' 10"	129 lbs
18509-243	5' - 9'	4' 11" - 8' 8.5"	15' 2"	5' - 7' 5"	9' 10"	133 lbs
18515-240	8' - 14'	7' 8.5" - 13' 5"	19' 11"	6' 8.5" - 10' 6"	12' 9"	151 lbs
18515-243	8' - 14'	7' 8.5" - 13' 5"	19' 11"	6' 8.5" - 10' 6"	12' 9"	156 lbs

* A 5' 6" PERSON WITH A 12" VERTICAL REACH
"AVAILABLE OPTIONS: -240 INCLUDES WHEEL LIFT AND NET, -243 INCLUDES WHEEL LIFT AND NET, ALL TERRAIN WHEELS"
BASE WIDTH: 3' 9.5"
** OUTRIGGERS NOT AVAILABLE ON 3'-5" MODELS

Little Giant[®]

Ladder Systems

1198 North Spring Creek Place
Springville, Utah 84663 USA

P: 866.872.5901
F: 801.489.9691

www.LittleGiantLadders.com
PAT. www.LittleGiantLadders.com/patents
©2020 Little Giant Ladder Systems 80328 v22 1.20