

# INSTALLATION INSTRUCTIONS AND OWNER'S MANUAL

## INSTALLER:

Leave this manual with the appliance.

## CONSUMER:

Retain this manual for future reference.

### ⚠ WARNING

#### FIRE OR EXPLOSION HAZARD

If the information in this manual is not followed exactly, a fire or explosion may result causing property damage, personal injury or loss of life.

- Do not store or use gasoline or other flammable vapors and liquids in the vicinity of this or any other appliance.
- **WHAT TO DO IF YOU SMELL GAS**
  - Do not try to light any appliance.
  - Do not touch any electrical switch; do not use any phone in your building.
  - Leave the building immediately.
  - Immediately call your gas supplier from a neighbor's phone. Follow the gas supplier's instructions.
  - If you cannot reach your gas supplier, call the fire department.
- Installation and service must be performed by a qualified installer, service agency or the gas supplier.

## DIRECT VENT ZERO CLEARANCE GAS FIREPLACE HEATER MODEL SERIES:

MILLIVOLT (MV)

DVCP36(PP,SP)30(N,P)-1

INTERMITTENT PILOT (IPI)

DVCP36(PP,SP)70(N,P)-1

UL FILE NO. MH30033

GAS-FIRED



### ⚠ WARNING

If not installed, operated and maintained in accordance with the manufacturer's instructions, this product could expose you to substances in fuel or from fuel combustion which can cause death or serious illness.

This appliance may be installed in an aftermarket, permanently located, manufactured home (USA only) or mobile home, where not prohibited by local codes.

This appliance is only for use with the type of gas indicated on the rating plate. This appliance is not convertible for use with other gases, unless a certified kit is used.

## ⚠ WARNING



**HOT GLASS WILL  
CAUSE BURNS.  
DO NOT TOUCH GLASS  
UNTIL COOLED.  
NEVER ALLOW CHILDREN  
TO TOUCH GLASS.**

A barrier designed to reduce the risk of burns from the hot viewing glass is provided with this appliance and shall be installed for the protection of children and other at-risk individuals.

NATIONAL  
FIREPLACE  
INSTITUTE



CERTIFIED  
[www.nficertified.org](http://www.nficertified.org)

We suggest that our gas hearth products be installed and serviced by professionals who are certified in the U.S. by the National Fireplace Institute® (NFI) as NFI Gas Specialists.

**NOTICE:** Barriers required and pre-installed on fireplace.

# BEFORE YOU START

## Sample Warnings and Definitions:

### DANGER

Indicates a hazardous situation which, if not avoided, will result in death or serious injury.

### WARNING

Indicates a hazardous situation which, if not avoided, could result in death or serious injury.

### CAUTION

Indicates a hazardous situation which, if not avoided, could result in minor or moderate injury.

**NOTICE:** Addresses practices not related to personal injury.

1. Read the safety information on Pages 75 - 76.
2. If located in the Commonwealth of Massachusetts, please note the special requirements on page 77.
3. Are you going to install a blower into the fireplace? See pages 8 - 9.
4. Where are you going to install the fireplace? See page 17.
5. Frame the opening. See page 19.
6. Install the gas lines. See page 16.
7. Install the wiring. See pages 59 and 63.
8. Install the venting. See pages 25 - 32.
9. Install the fireplace. See pages 19 - 24.
10. Connect the venting system. See pages 33 - 34.
11. Install the logs. See page 36 - 54.
12. Light the fireplace and troubleshoot. See pages 60 - 61 and 64 - 67.
13. Show the homeowner how to operate the fireplace.
14. Show the homeowner how to do the basic maintenance.

## Unpacking the fireplace

**NOTICE:** The barrier screens supplied with this fireplace may be damaged if force is applied to their surfaces. Take care not to push against barrier screens.

1. Cut binding straps and shrink wrap. Shrink wrap should be cut vertically along a corner post to avoid damage to barrier screens.
2. Remove and discard corner posts.
3. Remove and discard top plywood sheet.
4. Verify that the fireplace has not been damaged during shipping.
5. Remove non-combustible board on vent-end of fireplace and set aside (peninsula only).
6. Remove fireplace from pallet.
7. Remove non-combustible boards from pallet and set aside.
8. Set fireplace in a location near to its final installation location.

**NOTICE:** It is not necessary to remove the barrier screens from the glass frames in order to remove the glass frames (see page 69).

## Installation Considerations - Fireplace Installation Guidelines

When planning a fireplace installation, it's necessary to determine:

- If the desired location of the fireplace is compatible with the required framing dimensions, clearances to combustibles, venting requirements, etc.
- If optional accessories are desired.
- Routing of gas supply piping (vent-end entrance).
- Electrical connections - for IP control system or optional light or blower kit (vent-end connection)
- Electrical supply requirements for IP control system or optional light or blower kit. (120V, 60Hz, 1Amp) (Vent-end connection)

The fireplace can be mounted on any of these surfaces:

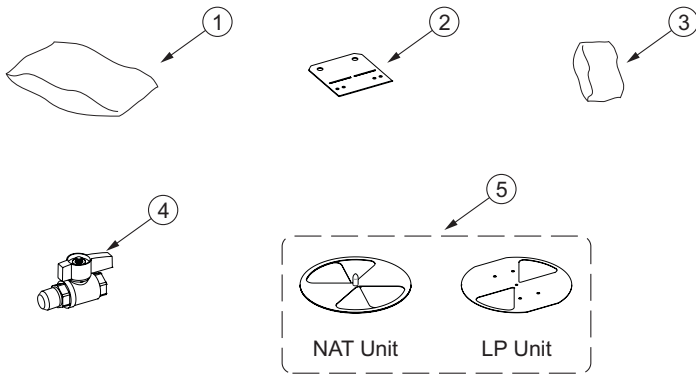
1. A flat hard combustible or non-combustible surface.
2. A raised platform of combustible or non-combustible material.
3. If allowed by local codes: A rectangular frame that contacts all four edges on the bottom of the fireplace.

If the fireplace is installed directly on carpeting, tile or other combustible material other than wood flooring, it should be installed on a metal or wood panel extending the full width and depth of the fireplace.

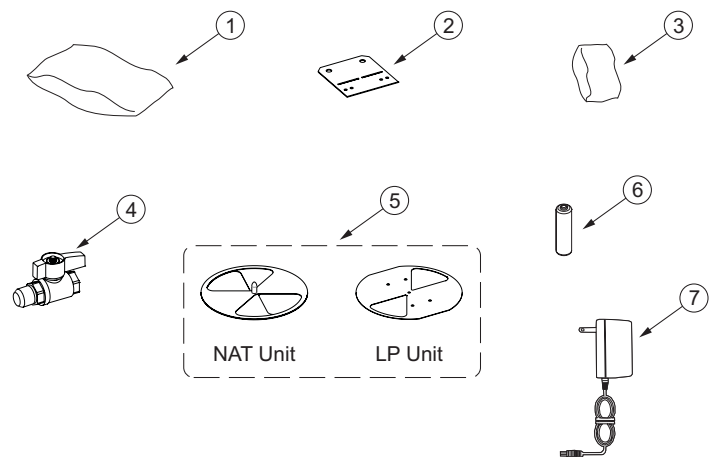
This fireplace is designed to be installed in a zero-clearance enclosure. This means the combustible material can come in contact with the top and side standoff spacers, and secured to combustible framing using the framing brackets provided.

# CARTON CONTENTS & HARDWARE PACK

## CARTON CONTENTS - DVCP36(PP,SP)3 SERIES



## CARTON CONTENTS - DVCP36(PP,SP)7 SERIES



Items not shown to scale.

INDEX NUMBER	DESCRIPTION	QUANTITY SUPPLIED
1	Rock Wool	1
2*	Nailing Flange	5
3	Hardware Pack	1
4	Shut-Off Valve	1
5	Flue Restrictor	1
NS	Non-Combustible Board - Long	2
NS**	Non-Combustible Board - Short	1
NS	Installation Instructions	1

NS - Not Shown in reference graphic.

\*Five required for Peninsula models. Four required for See-Thru models.

\*\*Peninsula models only.

See Parts Lists on pages 70 - 73 for ordering replacement parts. Do not order batteries, bolts, screws, washers or nuts. They are standard hardware items and can be purchased at any local hardware store.

Items not shown to scale.

INDEX NUMBER	DESCRIPTION	QUANTITY SUPPLIED
1	Rock Wool	1
2*	Nailing Flange	5
3	Hardware Pack	1
4	Shut-Off Valve	1
5	Flue Restrictor	1
6	Battery	4
7	AC Adapter	1
NS	Non-Combustible Board - Long	2
NS**	Non-Combustible Board - Short	1
NS	Installation Instructions	1

NS - Not Shown in reference graphic.

\*Five required for Peninsula models. Four required for See-Thru models.

\*\*Peninsula models only.

See Parts Lists on pages 70 - 73 for ordering replacement parts. Do not order batteries, bolts, screws, washers or nuts. They are standard hardware items and can be purchased at any local hardware store.

# TABLE OF CONTENTS

SECTION	PAGE
Introduction .....	5
Specifications .....	6
Accessories .....	7
Blower Installation.....	8 - 9
Fireplace Dimensions - See-Thru.....	10
Fireplace Dimensions - Peninsula.....	11
Clearances.....	12 - 13
Combustible Material.....	13
Vent Termination Clearances .....	14 - 15
Gas Supply .....	16
Locating Fireplace .....	17
Junction Box Wiring Installation Instructions.....	18
Installation.....	19 - 24
Venting Fireplace Top .....	25 - 32
Flue Restrictor .....	25
Below Grade Installation.....	25
Top Vent System Identification .....	26
Vent Systems .....	26
Venting Graph.....	27
Horizontal Termination.....	28
Vertical Termination.....	29 - 32
Venting Fireplace - Rear.....	32
DVVK-5F Flex Vent Instructions.....	33 - 34
Finishing Installation .....	35
Optional Fiber or Porcelain Liners.....	36
Glowing Embers .....	37
Log Identification - LSU24SPF .....	38
Log Placement - LSU24SPF.....	39 - 46
Log & Rock Identification - DG30MX.....	47 - 48
Log & Rock Placement - DG30MX.....	49 - 56
Millivolt Standing Pilot Operating Instructions .....	57 - 58
Millivolt Standing Pilot Wiring Diagram.....	59
Millivolt Standing Pilot Lighting Instructions.....	60
Millivolt Standing Pilot Troubleshooting .....	61
Intermittent Pilot Electronic System Operating Instructions .....	62
Intermittent Pilot Electronic System Wiring Diagram.....	63
Intermittent Pilot Lighting Instructions.....	64
Intermittent Pilot Control System Troubleshooting .....	65 - 67
Maintenance and Service.....	68 - 69
See-Thru Parts View .....	70
See-Thru Parts List.....	71
Peninsula Parts View.....	72
Peninsula Parts List.....	73
Master Parts Distributor List .....	74
How To Order Repair Parts .....	74
Important Safety Information .....	75
Safety Information for Users of LP Gas.....	76
Requirements for Massachusetts .....	77
Appliance Service History .....	78
Warranty .....	79

# INTRODUCTION

## Instructions to Installer

1. Leave instruction manual with owner after installation.
2. Have owner fill out and mail registration card supplied with the fireplace or online.
3. Show owner how to start and operate the fireplace.

This direct vent gas fireplace heater is designed to operate with all combustion air being siphoned from the outside of the building and all exhaust gases expelled to the outside of the building. The information contained in this manual pertains to all models and gas control systems.

## Fireplace Certification

### WARNING

**This fireplace is not for use with solid fuels. Improper use of the fireplace can cause serious injury or death from fire, burns, explosions, or carbon monoxide poisoning**

This fireplace is design certified in accordance with American National Standard/CSA Standard ANSI Z21.88/CSA 2.33 and by Underwriters Laboratories as a Direct Vent Gas Fireplace Heater and shall be installed according to these instructions. Consult your local building code agency, prior to installation, to ensure compliance with local codes including permits and inspections.

The fireplace, when installed, must be electrically grounded in accordance with local codes or, in absence of local codes, with the *National Electric Code ANSI/NFPA 70* or Canadian Electric code, CSA C22.1, if an external electrical source is utilized.

These models may be installed in a bedroom or bed-sitting room in the U.S.A. and Canada.

## Qualified Installing Agency

Installation and replacement of gas piping, gas utilization equipment or accessories and repair and servicing of equipment shall be performed only by a qualified agency. The term "qualified agency" means any individual, firm, corporation or company which either in person or through a representative is engaged in and is responsible for (a) the installation or replacement of gas piping or (b) the connection, installation, repair or servicing of equipment, who is experienced in such work, familiar with all precautions required and has complied with all the requirements of the authority having jurisdiction.

**Commonwealth of Massachusetts:** The installation must be made by a licensed plumber or gas fitter in the Commonwealth of Massachusetts.

### WARNING

**Any change to this fireplace or its controls can be dangerous. Improper installation or use of the fireplace can cause serious injury or death from fire, burns, explosions, or carbon monoxide poisoning.**

The installation must conform with local codes or, in the absence of local codes, with the *National Fuel Gas Code ANSI Z223.1/ NFPA 54\* Natural Gas and Propane Installation Code*, or *CSA B149.1 in Canada*. \*Available from the American National Standards Institute, Inc. 11 West 42nd St., New York, N.Y. 10036.

**Any alteration of the original design, installed other than as shown in these instructions or use with a type of gas not shown on the rating plate is the responsibility of the person and company making the change.**

## Important

All correspondence should refer to complete Model Number, Serial Number and type of gas.

## High Altitude

When installing this fireplace at an elevation above 2000 feet (in the United States) it may be necessary to decrease the input rating by changing the existing burner orifice to a smaller size. Generally, input should be reduced 4 percent for each 1000 feet above sea level. However, if the heating value of the gas has been reduced, this general rule may not apply. Check with Empire Comfort Systems for proper orifice size identification.

## Canadian High Altitude

Altitude: 0-4500 feet

When installing this fireplace at an elevation above 4500 feet (in Canada), check with Empire Comfort Systems.

Consult your Empire Comfort Systems for assistance in determining the proper orifice for location.

## Preparation

This direct vent gas fireplace and its components are tested and safe when installed in accordance with this Installation Manual. Report to your dealer any parts damaged in shipment, specifically check glass condition. Do not install fireplace with damaged, incomplete, or substitute parts. Read all instructions before starting installation and follow these instructions carefully during installation to insure maximum benefit and safety. Failure to follow them will void your warranty and may present a fire hazard. The warranty will be voided by, and the warranter disclaims any responsibility for the following actions:

- Installation of any damaged fireplace or vent system component.
- Modification of the fireplace or direct vent system.
- Installation other than as instructed by Empire Comfort Systems Inc.
- Improper positioning of the logs, decorative rock or glass door.
- Installation and/or use of any component part not manufactured or approved by manufacturer.

# SPECIFICATIONS

	NATURAL GAS		PROPANE GAS	
	PENINSULA MODELS	SEE-THRU MODELS	PENINSULA MODELS	SEE-THRU MODELS
Input BTU/Hr Maximum	34,000	34,000	32,000	32,000
Input BTU/Hr Minimum	23,000	23,000	26,500	26,500
KWH (Maximum)	9.96	9.96	9.38	9.38
KWH (Minimum)	6.74	6.74	7.76	7.76
Orifice	#33	#33	#51	#51
Air Shutter Opening*	3/16in (1/8in w/40ft. Vertical Vent, flue restrictor installed)	3/16in (1/8in w/40ft. Vertical Vent, flue restrictor installed)	FULLY OPEN	FULLY OPEN
Height without standoff	39-1/2in	39-1/2in	39-1/2in	39-1/2in
Width	42-1/4in	45-1/2in	42-1/4in	45-1/2in
Depth	24in	24in	24in	24in
Gas Inlet Shutoff Valve (pipe)	1/2 NPT	1/2 NPT	1/2 NPT	1/2 NPT
Venting	5" x 8", See Page 26	5" x 8", See Page 26	5" x 8", See Page 26	5" x 8", See Page 26

**\*NOTICE:** Air shutter settings are factory minimum settings. Some venting configurations may require minor air shutter adjustments for optimum performance.

GAS SUPPLY PRESSURES			
GAS TYPE	MAXIMUM	MINIMUM	MANIFOLD
NAT	14	4.5	3.5
LP	14	11	10

# ACCESSORIES

The following accessory parts can be obtained from your Empire Comfort Systems dealer. Contact your Empire Dealer for more accessory options. If you need additional information, contact Empire Comfort Systems Inc., 918 Freeburg Ave., Belleville, Illinois 62220-2623.

Model Number	Description	May Be Used On
**DVP36PRB	Rustic Brick Liner - "Soldier Course"	Peninsula & See-Thru Models
**DVP36PFLKR	Vertical Fluted Black Liner	Peninsula & See-Thru Models
**DVP36PKR	Porcelain Black Liner	Peninsula & See-Thru Models
FBB14	Blower Kit	Peninsula & See-Thru Models
LK7	Light Kit	Peninsula & See-Thru Models
*LSU24SPF	Campfire Log Set	Peninsula & See-Thru Models
*DG36MX	Rustic Decorative Boulders	Peninsula & See-Thru Models
DF362PNB	1.5in. Beveled Window Frame, Brushed Nickel	Peninsula & See-Thru Models
DF242NB	1.5in. Beveled Window Frame End, Brushed Nickel	Peninsula Models Only
DF362PBZ	1.5in. Beveled Window Frame - Oil Rubbed Bronze	Peninsula & See-Thru Models
DF242BZ	1.5in. Beveled Window Frame End - Oil Rubbed Bronze	Peninsula Models Only
DVD36PBLNB	Decorative Contemporary Doors - Brushed Nickel	Peninsula & See-Thru Models

\* Fireplace requires a log set or mixed logs and stones kit.

\*\* Liners are not required. To add liners, order two liners for See-Through models; One for Peninsula.

Remote Control Options And Accessories	Description	Models Used On
FRBC	Millivolt Battery Remote ON/OFF	DVCP36(PP,SP)(3,7)
FRBTC	Millivolt Battery Remote Thermostat	DVCP36(PP,SP)(3,7)
TMW	Millivolt Wireless Wall Thermostat	DVCP36(PP,SP)(3,7)
TRW	Millivolt Reed Switch Wall Thermostat	DVCP36(PP,SP)(3,7)
FWS-1	Direct Ignition/Millivolt Wall Switch	DVCP36(PP,SP)(3,7)
FRBTP	Battery Operated Remote Control with Programmable Thermostat	DVCP36(PP,SP)(3,7)
RVKN-1	Remote Kit, NAT (Stepper Motor)	DVCP36(PP,SP)70(N,P)
RVKP-1	Remote Kit, LP (Stepper Motor)	DVCP36(PP,SP)70(N,P)

# BLOWER INSTALLATION

1. Remove the glass and screen frames, and the bottom access panel from the side which is opposite the valve. The glass and screen frame may be removed as a unit. It is not necessary to separate the screen frame from the glass frame.
2. Hold the blower assembly so that the magnets are on your right side, and insert it into the fireplace through the opening to the right of the junction box. **See Figure 1.**

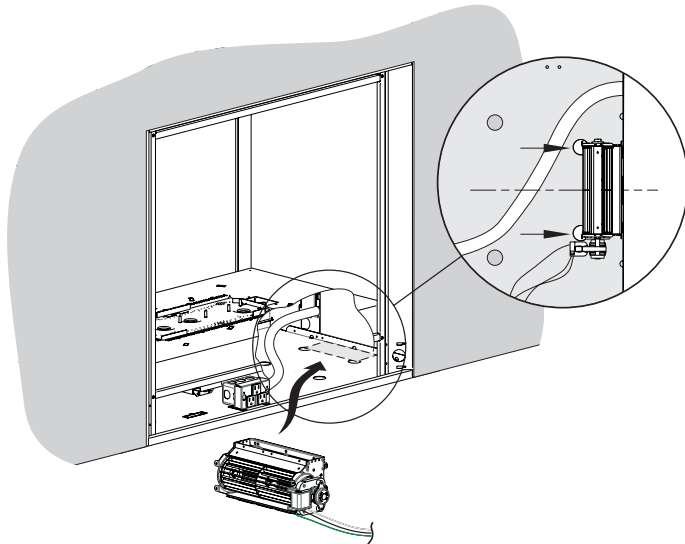


Figure 1

3. Attach the magnet-side of the blower assembly to the outer wall of the fireplace, and center it inside the fireplace using the two holes in the floor as a visual guide. **See Figure 1.**
4. Set the rheostat control on the fireplace floor, with the rheostat bracket situated as far to the right as possible. **See Figure 2.**

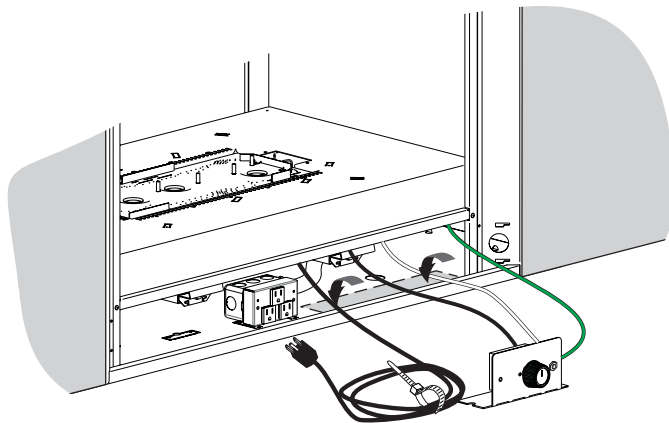


Figure 2

5. Snap the fan control disc into the forked prongs on the valve bracket. **See Figure 3.**

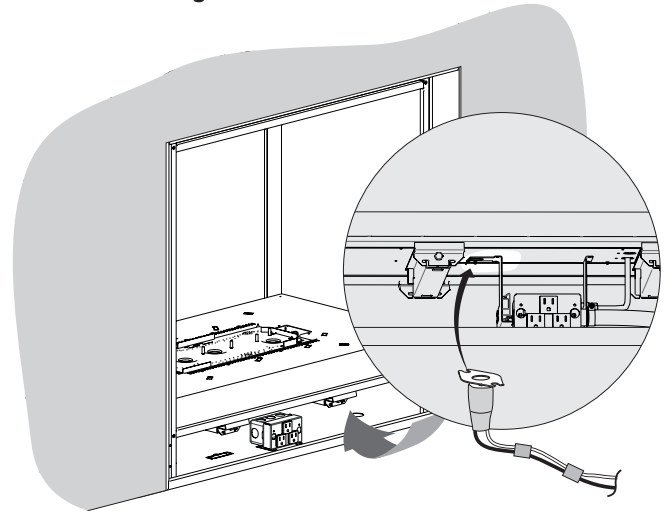


Figure 3

6. If more than one receptical is necessary in order to complete the installation, unscrew the junction box from the locating tabs so that it can be moved rearwards and plug the blower cord into one of the two bottom recepticals. **See Figures 4 and 5.**

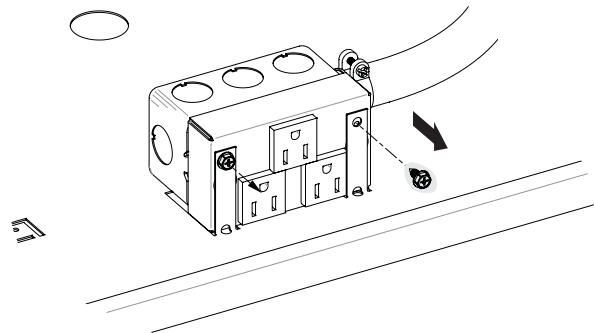


Figure 4

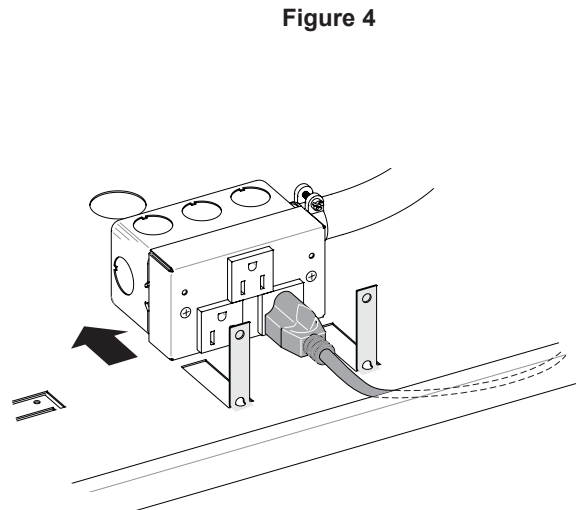
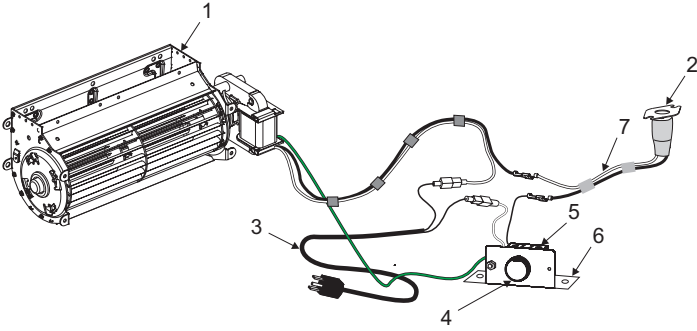


Figure 5

7. Re-attach the junction box to the locating tabs.
8. Re-install the glass and screen frames, and the access panel.



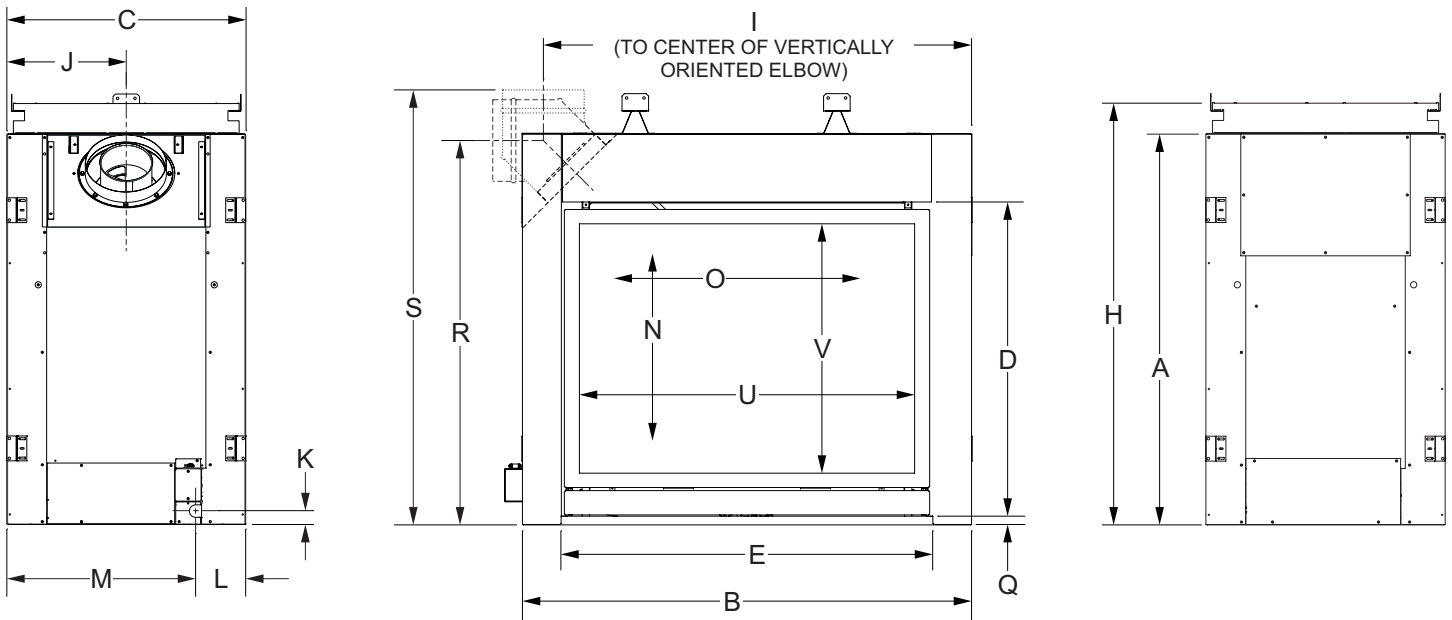
# BLOWER INSTALLATION (CONT'D)



**BLOWER ASSEMBLY PARTS LIST**

INDEX NO.	PART NO.	DESCRIPTION	QTY.
1	36118	BLOWER ASSEMBLY	1
2	R7649	FAN, CONTROL L120-20	1
3	R3529	CORD SET, 30 INCHES	1
4	R4192	RHEOSTAT, KNOB	1
5	R4186	RHEOSTAT, 3.0 AMP 115 VAC	1
6	10088	RHEOSTAT BOX BRACKET	1
7	R11768	WIRE HARNESS, FAN CONTROL	1

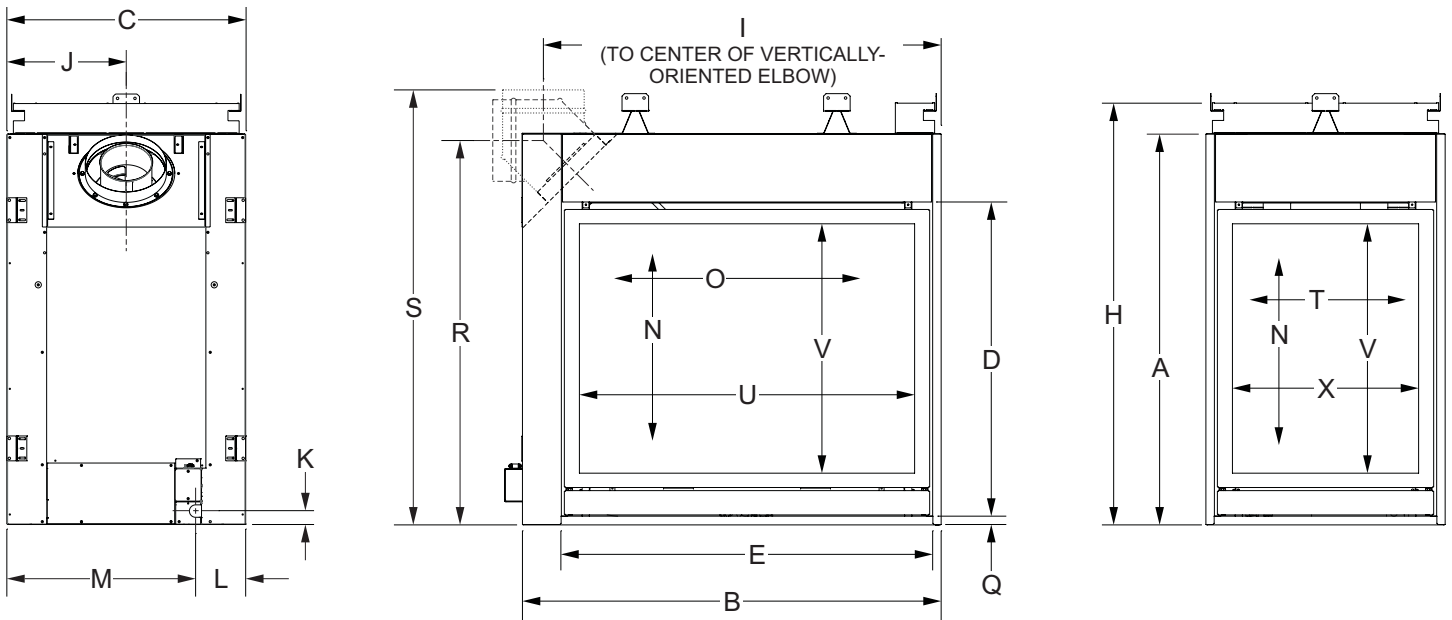
# FIREPLACE DIMENSIONS - SEE-THRU



INDEX LETTER	DIMENSION DESCRIPTION	DVCP36SP(30,70) (Dimensions in Inches)
A	The maximum height of firebox face (excluding standoffs)	39-1/4
B	The maximum width of the firebox face (excluding nailing flanges)	45
C	The maximum depth of the firebox	24
D	The height of the firebox opening	31-1/2
E	The width of the firebox opening	37-1/4
F	The interior depth of the firebox (not shown)	20-1/4
H	The height to the firebox standoffs	42-3/8
I	Width from the left side of the box to the centerline of vertical vent	48-5/8
J	Depth from back of box to centerline of vent	12
K	Height from the bottom of the box to the gas line opening	1-3/8
L	Depth from the front of the box to gas line opening	5
M	Depth from rear of box to gas line opening	19
N*	Glass height	25-3/8
O*	Glass width	31
Q	Distance from floor to fireplace opening	7/8
R	Height from floor to vent collar center line - Horizontal	39-1/2
S	Height from floor to vent collar - Vertical	44
U	Screen opening width	33-5/8
V	Screen opening height	25

\*These dimensions are to the inside edges of the glass frame opening.

# FIREPLACE DIMENSIONS - PENINSULA



INDEX LETTER	DIMENSION DESCRIPTION	DVCP36PP(30,70) (Dimensions in Inches)
A	The maximum height of firebox face (excluding standoffs)	39-1/4
B	The maximum width of the firebox face (excluding nailing flanges)	42
C	The maximum depth of the firebox	24
D	The height of the firebox opening	31-1/2
E	The width of the firebox opening	37-1/4
F	The interior depth of the firebox (not shown)	20-1/4
H	The height to the firebox standoffs	42-3/8
I	Width from the left side of the box to the centerline of vent	45-5/8
J	Depth from back of box to centerline of vent	12
K	Height from the bottom of the box to the gas line opening	1-3/8
L	Depth from the front of the box to gas line opening	5
M	Depth from rear of box to gas line opening	19
N*	Glass height	25-3/8
O*	Glass width	31
Q	Distance from floor to fireplace opening	7/8
R	Height from floor to vent collar - Horizontal	39-1/2
S	Height from floor to vent collar - Vertical	44
T*	Glass width - small	16
U	Screen opening width	33-5/8
V	Screen opening height	25
X	Screen opening width - small	18-5/8

\*These dimensions are to the inside edges of the glass frame opening.

# CLEARANCES

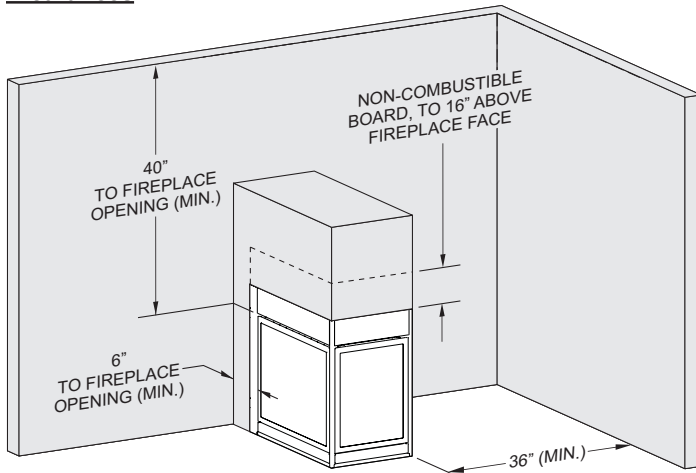
## Television Considerations

Installing a television above a fireplace has become increasingly popular; however, the area above any fireplace gets hot and most TV manufacturers recommend against placing their products near a heat source.

If you install a television above this fireplace, Empire Comfort Systems accepts no responsibility for damage or injuries. Follow the television manufacturer's installation instructions, including any recommendations regarding proximity to heat sources.

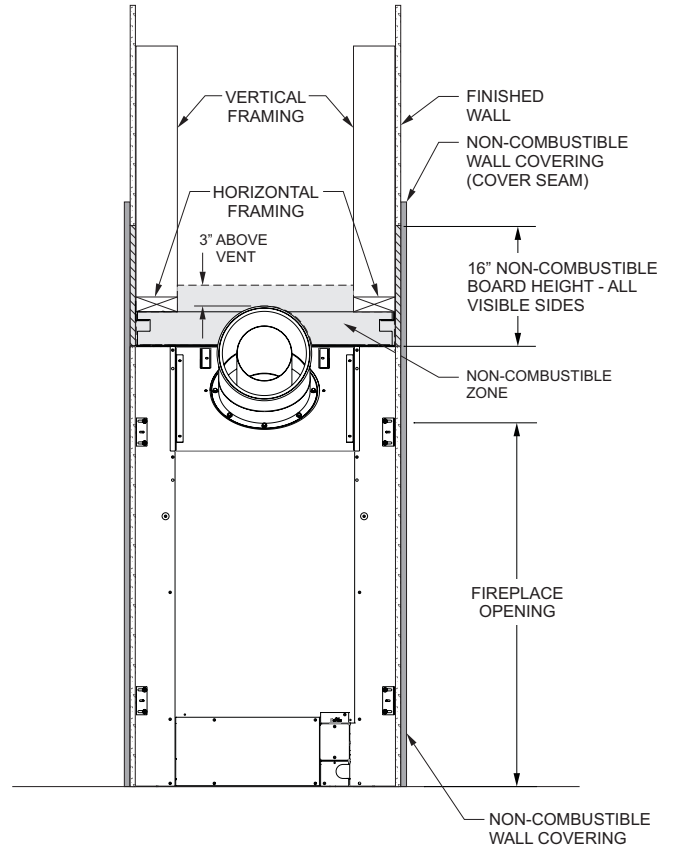
If you have a TV above your fireplace, turn off the fireplace and let it cool completely before servicing or touching any buttons on the TV.

## Clearances



**NOTICE:** Dimensions apply to both See-Thru and Peninsula models.

Figure 6 - Peninsula



**NOTICE A:** See Figure 9 for maximum mantel depth and minimum height above fireplace.

Figure 7

CLEARANCE TO COMBUSTIBLES	
Back	0in
Sides Near Face (See Figure 8)	0in
Floor	0in
Top Stand-off	0in
Outer Top to Framing	3in
Above Vent	3in

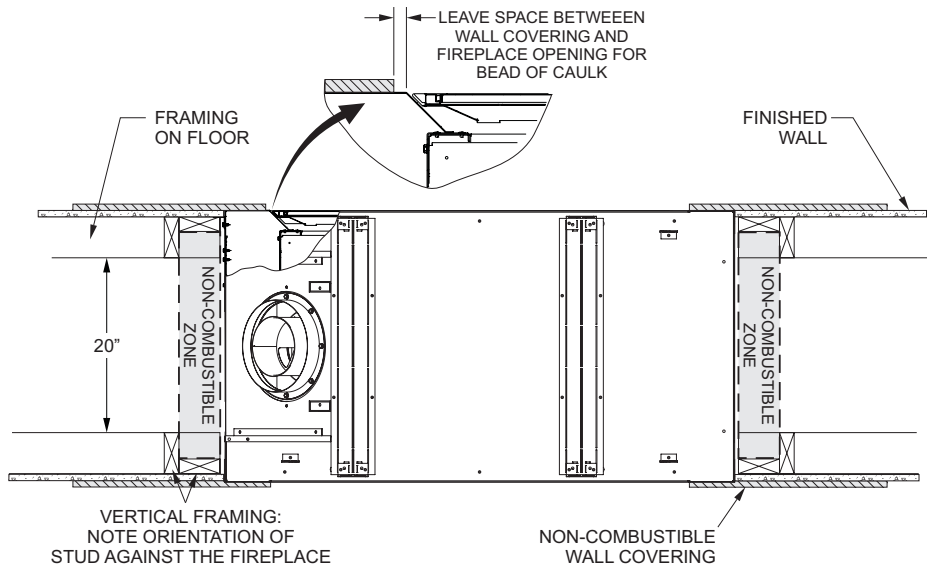
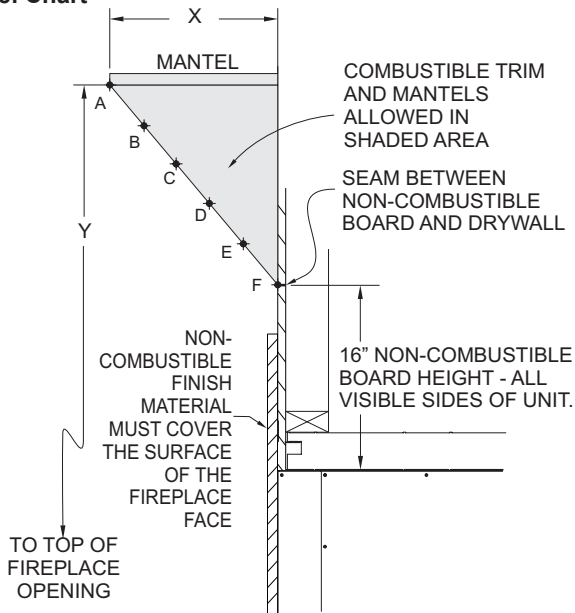


Figure 8

# CLEARANCES

## Mantel Chart



INDEX LETTER	Y - DISTANCE FROM FIREPLACE OPENING	X - DISTANCE FROM FINISHED WALL
	(Dimensions in Inches)	
A	26	12
B	24	8
C	22	6
D	20	4-1/2
E	18	2-1/4
F	16	0

Figure 9

# COMBUSTIBLE MATERIAL

Do not attach combustible material to the mantel of your fireplace. This is a fire hazard. No greeting card, stockings or ornamentation of any type should be placed on or attached to the fireplace. This is a heating fireplace. The flow of heat can ignite combustibles.

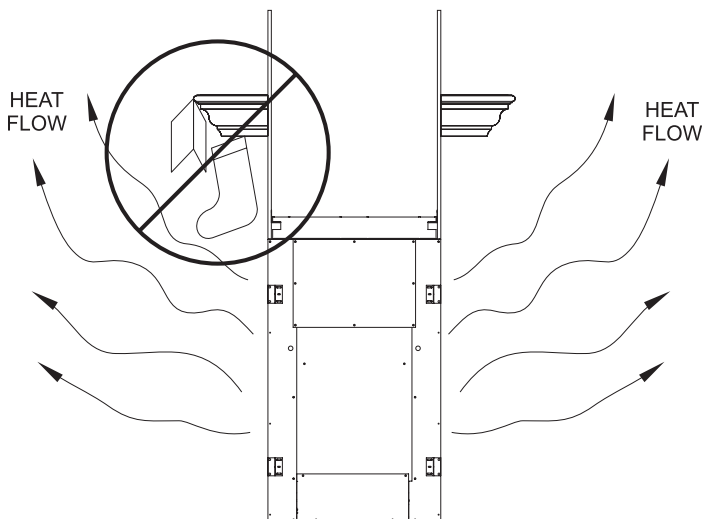


Figure 10

# VENT TERMINATION CLEARANCES

Termination clearance for buildings with combustible and noncombustible exteriors.

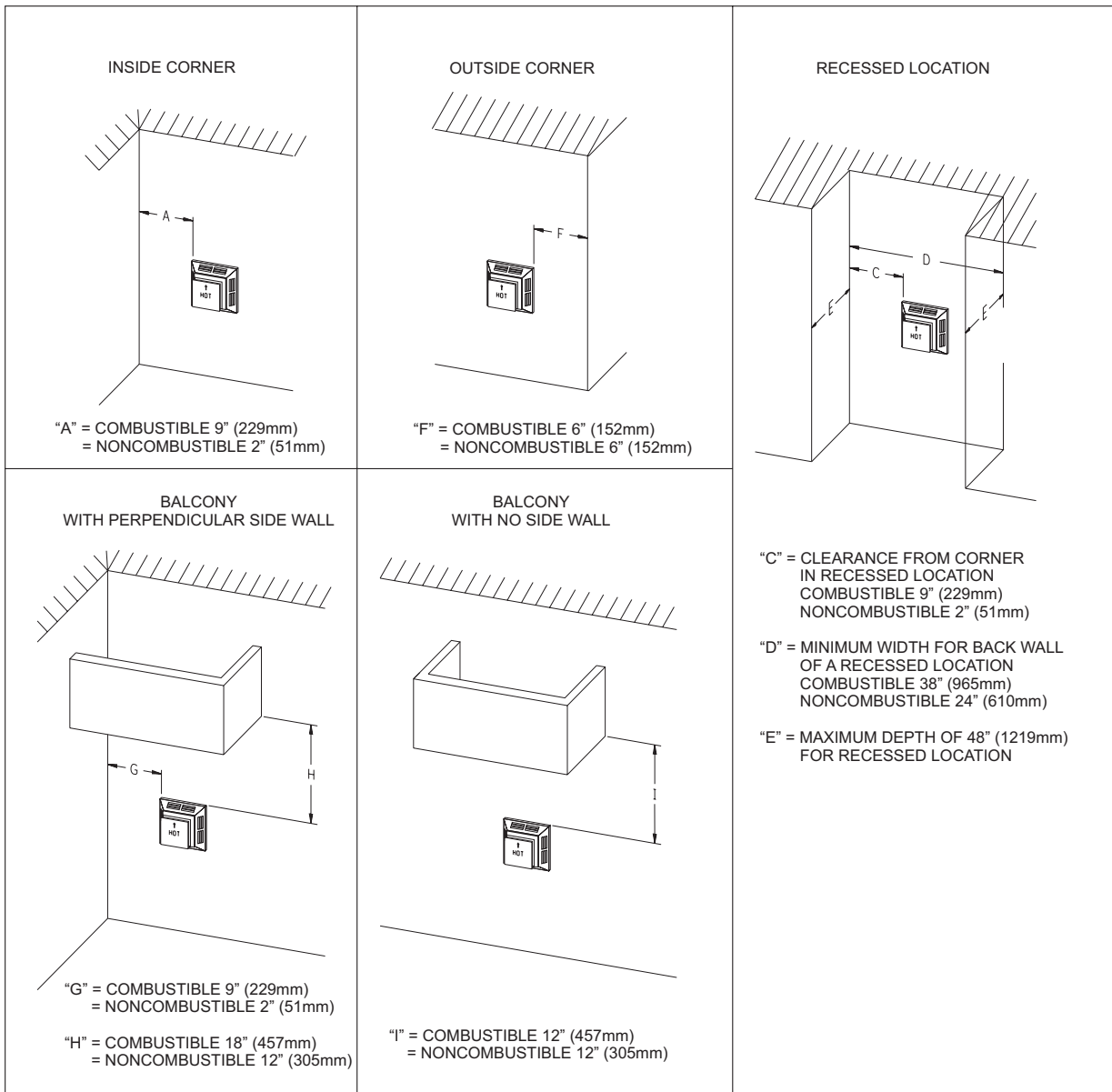


Figure 11

## Vertical Sidewall Installations

**Important!** Minimum clearance between vent pipes and combustible materials is 3 inch on top, and 1 inch on bottom and sides.

**Important!** When vent termination exits through foundation less than 20 inch below siding outcrop, the vent pipe must extend outward so that the horizontal vent termination is located flush to, or beyond the outcrop siding.

## Information on Various Venting Routes and Components

**Important:** It is always best to locate the fireplace in such a way that minimizes the number of offsets and horizontal vent length.

Since it is very important that the venting system maintain its balance between the combustion air intake and the flue gas exhaust, certain limitations as to vent configurations apply and must be strictly adhered to. See allowed vent configurations, page 28 to 32.

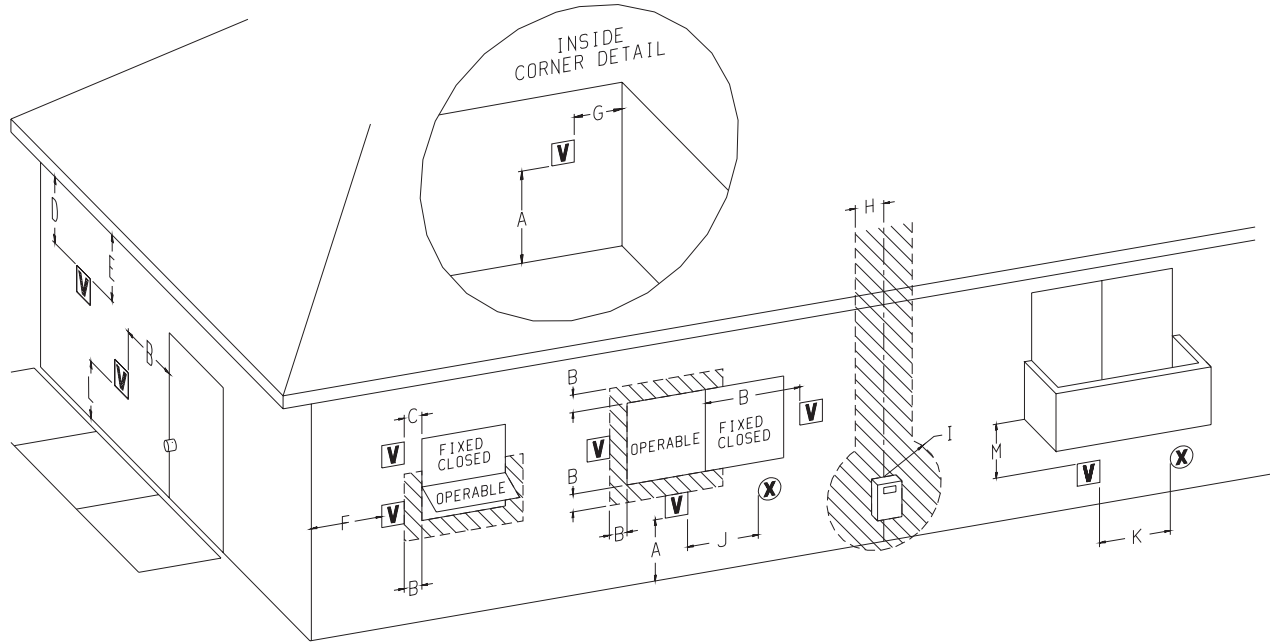
The horizontal vent run refers to the total length of vent pipe from the flue collar of the fireplace to the face of the outer wall.

Venting termination shall not be recessed into wall or siding.

### ATTENTION: Vinyl Soffit, Vinyl Ceiling, Vinyl Overhang Disclaimer

Clearances are to heat resistant material (i.e. wood, metal). This does not include vinyl. Empire Comfort Systems Inc. will not be held responsible for heat damage caused from terminating under vinyl overhangs, vinyl ceilings or vinyl ventilated/unventilated soffits.

# VENT TERMINATION CLEARANCES



VENT TERMINAL



AIR SUPPLY INLET



AREA WHERE TERMINAL IS NOT PERMITTED

	Canadian Installations <sup>1</sup>	US Installations <sup>2</sup>
A= Clearance above grade, veranda, porch, deck, or balcony	12 in (30 cm)	12 in (30cm)
B= Clearance to window or door that may be open	6 in (15 cm) for appliances ≤ 10,000 Btuh (3 kW), 12 in (30 cm) for appliances > 10,000 Btuh (3 kW) and ≤ 100,000 Btuh (30 kW), 36 in (91 cm) for appliances > 100,000 Btuh (30 kW)	6 in (15 cm) for appliances ≤ 10,000 Btuh (3 kW), 9 in (23 cm) for appliances > 10,000 Btuh (3 kW) and ≤ 50,000 Btuh (15 kW), 12 in (30 cm) for appliances > 50,000 Btuh (15 kW)
C= Clearance to permanently closed window	12 in (30 cm)	12 in (30 cm)
D= Vertical clearance ventilated soffit located above the terminal within a horizontal distance of 2 feet (61 cm) from the center line of the terminal	24 in (61 cm)	24 in (61 cm)
E= Clearance to unventilated soffit	12 in (30 cm)	12 in (30 cm)
F= Clearance to outside corner	6 in (15 cm)	6 in (15 cm)
G= Clearance inside corner	9 in (23 cm)	9 in (23 cm)
H= Clearance to each side of center line extended above meter/regulator assembly	3 ft (91 cm) within a height 15 ft (4.5 m) above the meter/regulator assembly	3 ft (91 cm)

	Canadian Installations <sup>1</sup>	US Installations <sup>2</sup>
I= Clearance to service regulator vent outlet	3 ft (91 cm)	6 ft
J= Clearance to nonmechanical air supply inlet to building or the combustion air inlet to any other appliance	6 in (15 cm) for appliances ≤ 10,000 Btuh (3 kW), 12 in (30 cm) for appliances > 10,000 Btuh (3 kW) and ≤ 100,000 Btuh (30 kW), 36 in (91 cm) for appliances > 100,000 Btuh (30 kW)	6 in (15 cm) for appliances ≤ 10,000 Btuh (3 kW), 9 in (23 cm) for appliances > 10,000 Btuh (3 kW) and ≤ 50,000 Btuh (15 kW), 12 in (30 cm) for appliances > 50,000 Btuh (15 kW)
K= Clearance to a mechanical air supply inlet	6 ft (1.83 m)	3 ft (91 cm) above if within 10 ft (3 m) horizontally
L= Clearance above paved sidewalk or paved driveway located on public property	7 ft (2.13 m) †	7 ft (2.13 m) †
M= Clearance under veranda, porch, deck, or balcony	12 in (30 cm) ‡	12 in (30 cm) ‡
1	In accordance with the current CSA B149.1, Natural Gas and Propane Installation Code	
2	In Accordance with the current ANSI Z223.1/NFPA 54, National Fuel Gas Code	
†	A vent shall not terminate directly above a sidewalk or paved driveway that is located between two single family dwellings and serves both dwellings	

‡ Permitted only if veranda, porch, deck, or balcony is fully open on a minimum of two sides beneath the floor.

\* For clearances not specified in ANSI Z223.1/NFPA 54 or CSA B149.1, one of the following shall be indicated:

Clearance in accordance with local installation codes and the requirements of the gas supplier.

## ATTENTION: Vinyl Soffit, Vinyl Ceiling, Vinyl Overhang Disclaimer

Clearances are to heat resistant material (i.e. wood, metal). This does not include vinyl. Empire Comfort Systems Inc. will not be held responsible for heat damage caused from terminating under vinyl overhangs, vinyl ceilings or vinyl ventilated/unventilated soffits.

# GAS SUPPLY

The gas pipeline can be brought in through the vent-end of the fireplace only. Consult the current National Fuel Gas Code, ANSI Z223.1 installation code.

## RECOMMENDED GAS PIPE DIAMETER

PIPE LENGTH	SCHEDULE 40 PIPE INSIDE DIAMETER		TUBING, TYPE L OUTSIDE DIAMETER	
	(Dimensions in Inches)			
	NAT	LP	NAT	LP
0-10 feet	1/2	3/8	1/2	3/8
10-40 feet	1/2	1/2	5/8	1/2
40-100 feet	1/2	1/2	3/4	1/2
100-150 feet	3/4	1/2	7/8	3/4

**NOTICE:** Never use plastic pipe. Check to confirm whether your local codes allow copper tubing or galvanized.

**NOTICE:** Since some municipalities have additional local codes, it is always best to consult your local authority and installation code.

The use of the following gas connectors is recommended:

- ANSI Z21.24 Appliance Connectors of Corrugated Metal Tubing and Fittings.
- ANSI Z21.45 Assembled Flexible Appliance Connectors of Other Than All-Metal Construction

The above connectors may be used if acceptable by the authority having jurisdiction. The state of Massachusetts requires that a flexible appliance connector cannot exceed three feet in length.

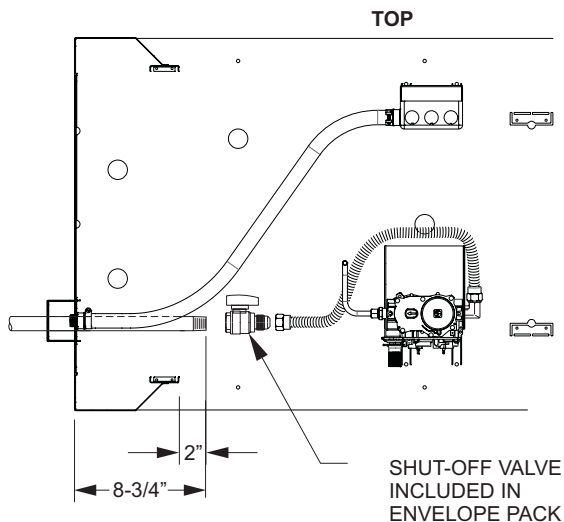


Figure 12

	GAS SUPPLY PRESSURE (INCHES W.C.)		
	MINIMUM	NORMAL	MAXIMUM
Natural Gas	4.5	7.0	14.0
LP (Propane)	10.8	11.0	14.0
Manifold Pressure (inches w.c.)			
Normal (HI)			
Natural Gas	3.5		
LP (Propane)	10.0		

A gas valve and ground joint union should be installed in the gas line upstream of the gas control to aid in servicing. It is required by the National Fuel Gas Code that a drip leg be installed near the gas inlet. **See Figure 13.** This should consist of a vertical length of pipe tee connected into the gas line that is capped on the bottom in which condensation and foreign particles may collect.

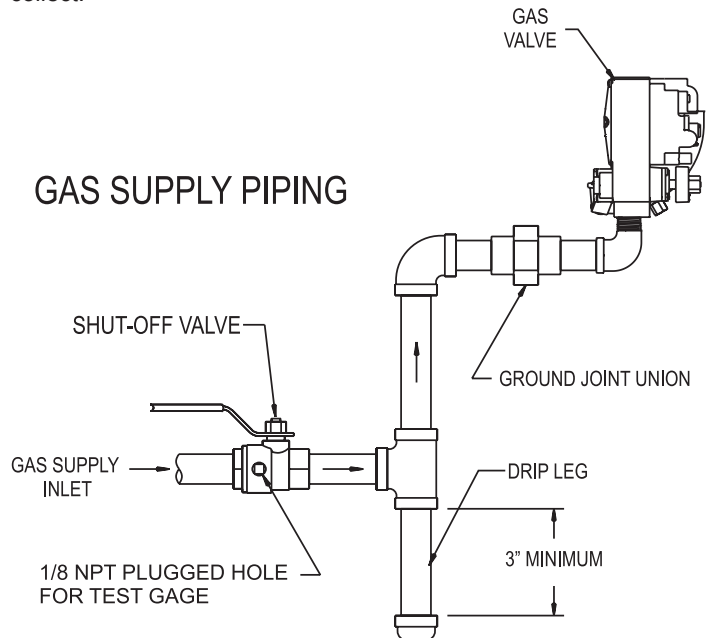


Figure 13

## GAS SUPPLY PIPING

## FLEXIBLE GAS LINE CONNECTION

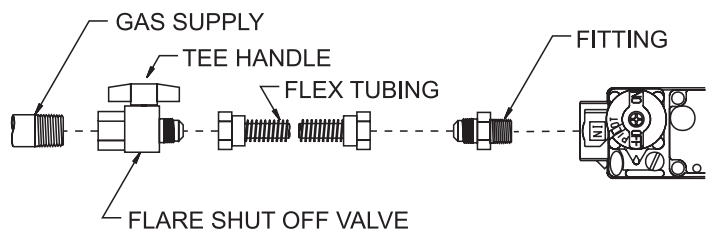
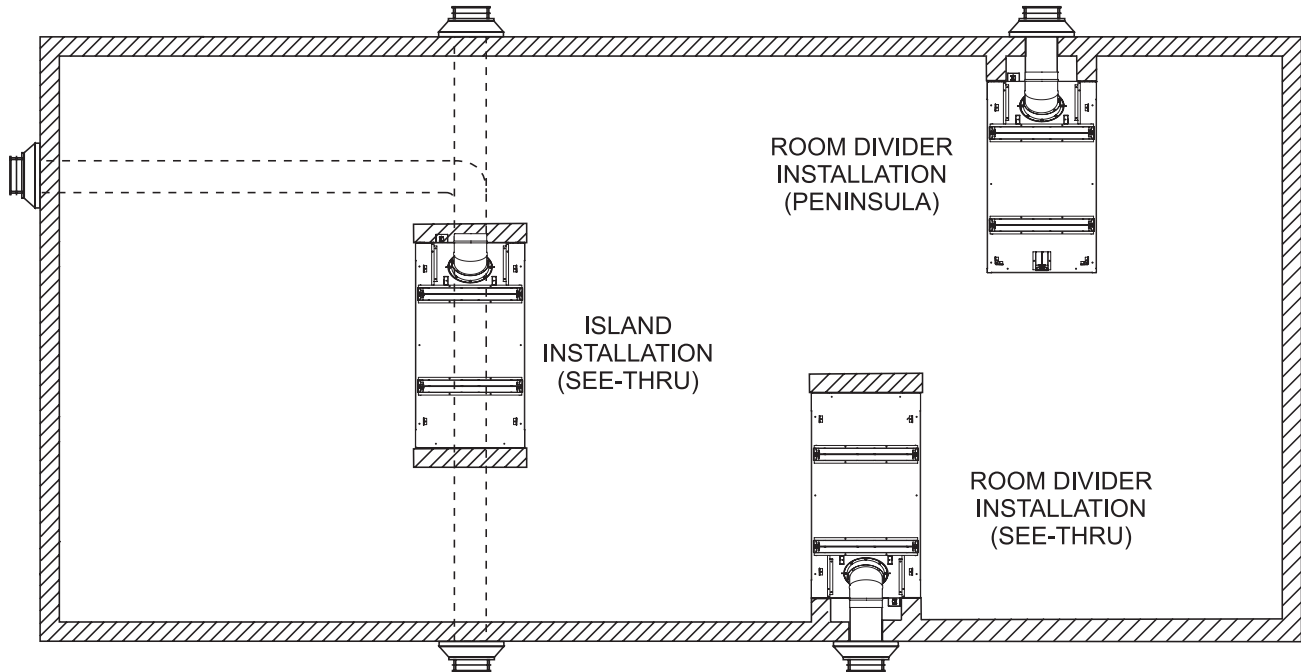


Figure 14



# LOCATING FIREPLACE



**NOTICE:** Island and Room Divider installation is possible as long as the horizontal portion of the vent system does not exceed 20 feet with a minimum vertical run of 8 feet from fireplace floor. See details in Venting Section.

**NOTICE:** Insulate to applicable codes when installing this fireplace against an exterior wall.

A minimum clearance of 6 inches must be maintained from the perpendicular wall to the firebox opening of the fireplace, if the fireplace is installed in the room divider or peninsula room divider positions.

Figure 15

# JUNCTION BOX WIRING INSTALLATION INSTRUCTIONS

## ⚠ WARNING

All wiring should be done by a qualified electrician and shall be in compliance with all local, city and state building codes. Before making the electrical connection, make sure that main power supply is disconnected. The fireplace, when installed, must be electrically grounded in accordance with local codes or, in the absence of local codes, with the National Electrical Code ANSI/NFPA 70 (latest edition). Improper installation of the fireplace can cause serious injury or death from fire, burns, explosions, or carbon monoxide poisoning.

A factory installed junction box is located on the outside wall of the fireplace on the vent side. Wiring must be fed to the junction box and attached to the stranded wire inside with wire nuts. Connect white to white, black to black, and ground (green stranded wire) to the ground screw inside the junction box. See Figure 16.

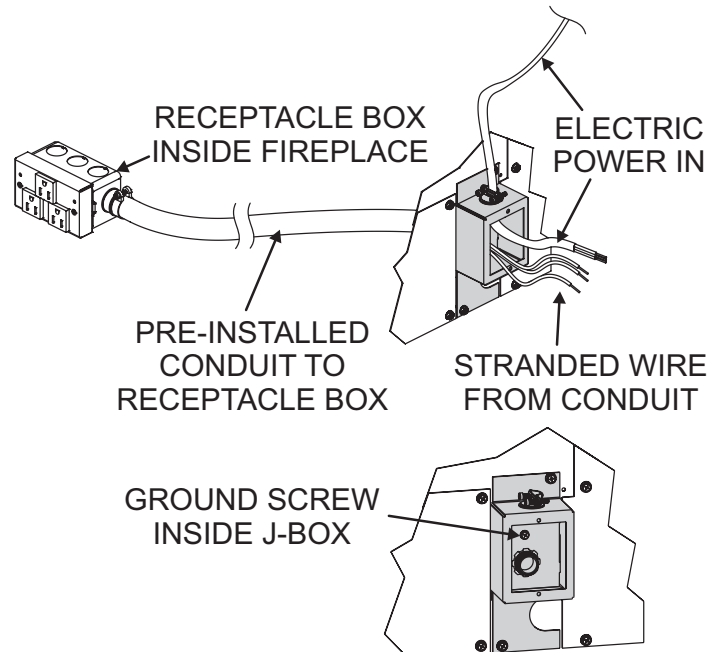


Figure 16

# INSTALLATION

## Vent Runs

In planning the installation for the fireplace, it is necessary to install certain components before the fireplace is completely positioned and installed. These include the direct vent system, gas piping for the fireplace and the electrical wiring. Study the "Venting Fireplace" section starting on page 25 to understand allowable vent runs.

## Positioning the Fireplace

Determine the exact position of the fireplace so the direct vent termination will be centered (if possible) between two studs. This will avoid any extra framing. All vent kit pipes should be assembled on the fireplace after the fireplace is moved into the final position.

The fireplace can be mounted on any of the following surfaces:

1. A flat hard combustible or non-combustible surface.
2. A raised platform of combustible or non-combustible material.
3. A rectangular frame constructed such that contact is made on all four perimeter edges on the bottom of the fireplace (if local codes allow).

## Framing

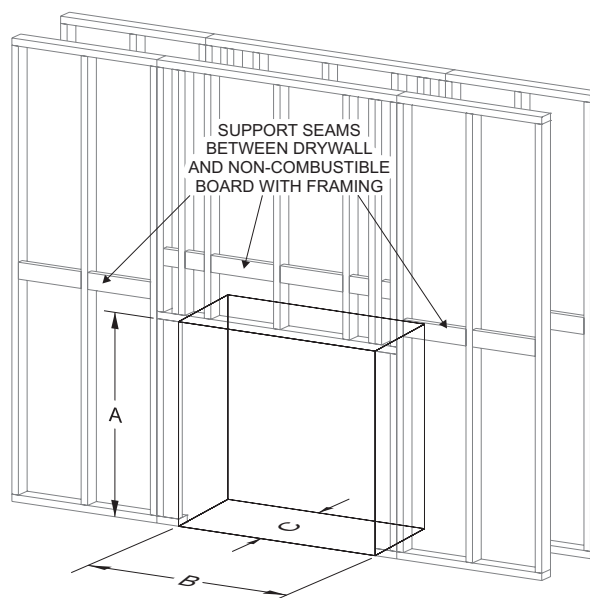
Fireplace framing can be built before or after the fireplace is set in place. Framing should be positioned to accommodate wall covering and fireplace facing material. The fireplace framing should be constructed of 2 x 4 lumber. The framing members may rest on the fireplace standoffs, however the stand-offs are not load-bearing. Refer to **Figures 17 and 18** for minimum framing dimensions.

You may install a see-through fireplace in a load-bearing wall, however the wall's framing must include a structural header above the fireplace designed to support all of the weight. Installing a peninsula unit requires special framing techniques above the fireplace to minimize the amount of weight on the fireplace – especially if you plan to finish the installation with stone or tile. This may include additional structural members in the ceiling to support the weight.

### ⚠ CAUTION

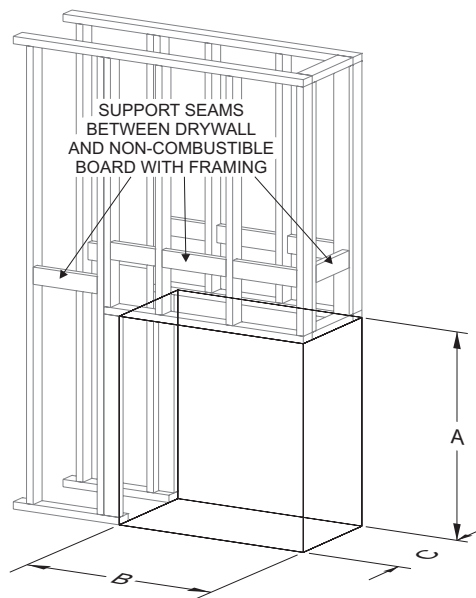
**To avoid unnecessary rework, measure fireplace dimensions and verify framing methods, and wall covering details before framing construction begins.**

**NOTICE:** Framing dimension A includes a three inch clearance for standoffs on firebox. After installing firebox into framing, the non-combustible board will cover the three inch opening above the firebox. See **Figure 19**.



	DVCP36SP (Dimensions in inches)
A	42-1/2
B	45-1/2
C	23

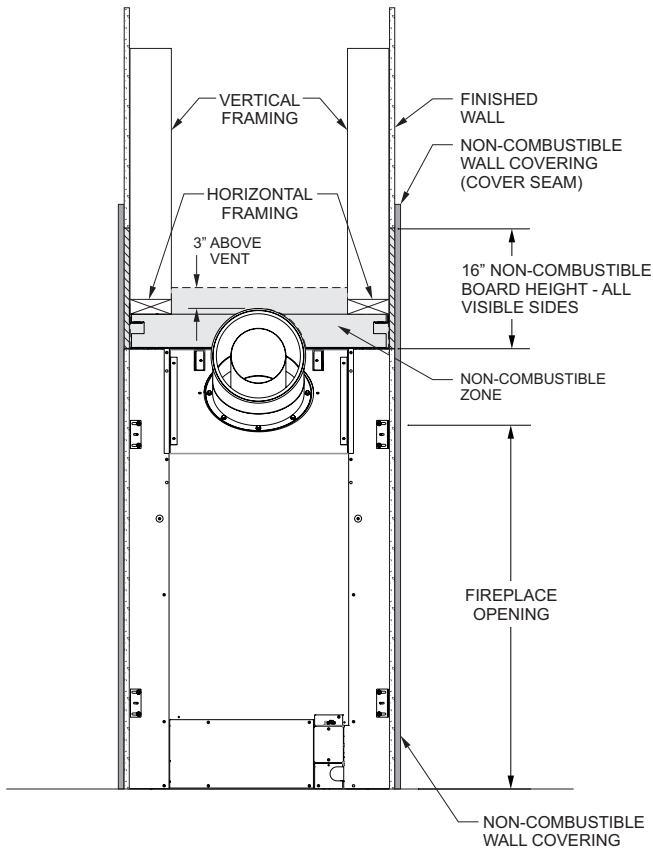
Figure 17 - See-Thru



	DVCP36PP (Dimensions in inches)
A	42-1/2
B	41-3/4
C	23

Figure 18 - Peninsula

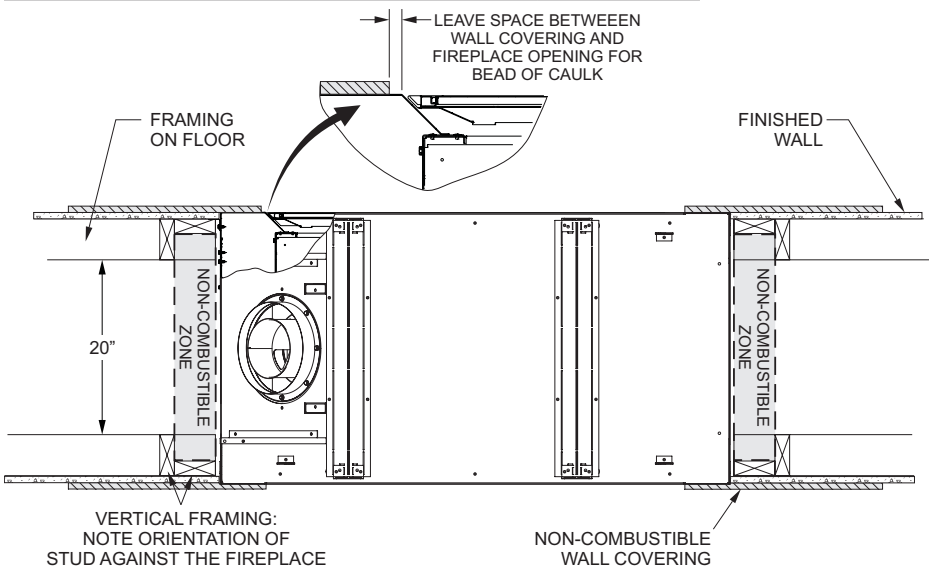
# INSTALLATION



**NOTICE:** See Figure 9 on page 13 for maximum mantel depth and minimum height above fireplace.

**Figure 19**

CLEARANCE TO COMBUSTIBLES	
Back	0in
Sides Near Face (See Figure 20)	0in
Floor	0in
Top Stand-off	0in
Outer Top to Framing	3in
Above Vent	3in

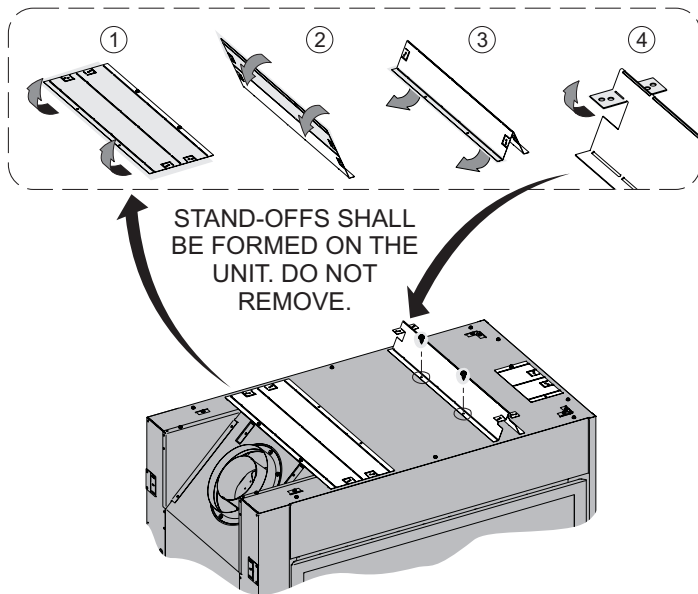


**Figure 20**

# INSTALLATION

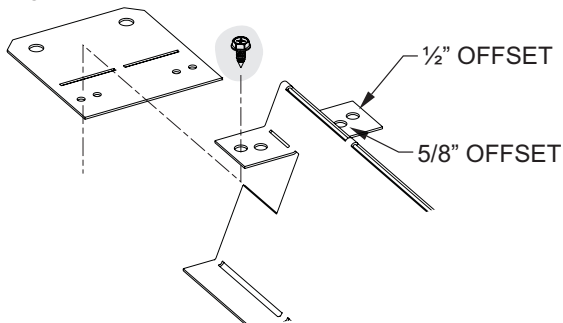
## Framing

1. Before placing the fireplace inside the frame work, or building the frame work around the fireplace, the top stand-offs must be formed and secured. Form the top stand-offs in the sequence shown in **Figure 21**, and secure them to the firebox outer top using either four (SP) or five (PP) screws from your hardware pack.



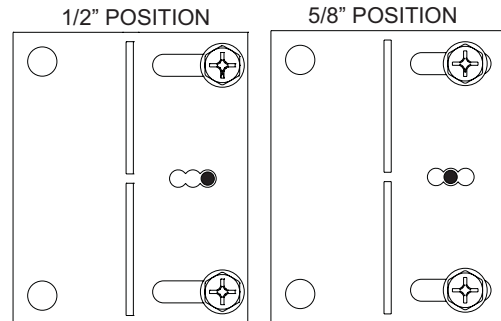
**Figure 21**

2. Attach four (SP) or five (PP) top-side nailing flanges to the top stand-offs as shown in **Figure 22**. Leave the nailing flanges flat at this time. Note that while the non-combustible board provided with this fireplace is  $\frac{1}{2}$ " thick, some adjustment of the nailing flange position can be made by using either the outer or inner pair of holes.



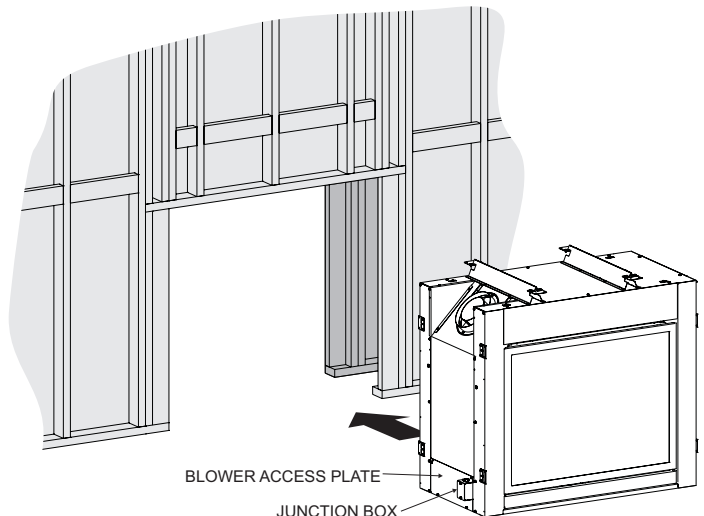
**Figure 22**

3. If necessary, the positions of the side nailing flanges can be adjusted by loosening (but do not remove) the top and bottom screws, anchoring the bracket in place using a center screw from the hardware pack, and re-tightening the top and bottom screws. **See Figure 23.**

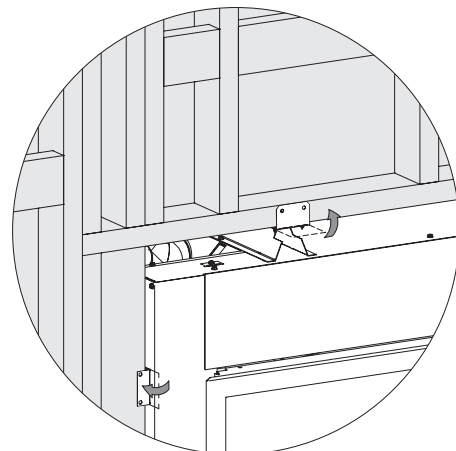


**Figure 23**

4. After the fireplace has been properly positioned inside the frame work, or the frame work has been built around the fireplace, the nailing flanges shall be bent 90 degrees and the fireplace should be attached to the frame work using 24 (SP) or 18 (PP) drywall screws. Temporarily remove blower access plate and tuck junction box inside fireplace before setting in place. **See Figure 24.**



**Figure 24**

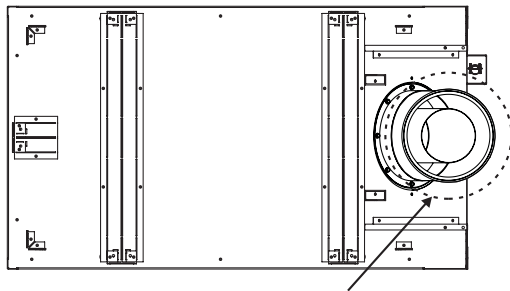


**Figure 25**

# INSTALLATION

## Vertical Vent Pipe Clearance

**NOTICE:** Need 2-inch clearance around pipe for the first 12 inches above Firebox. See Figure 26.



2" MIN. CLEARANCE  
AROUND VENT PIPE

Figure 26

## Horizontal Vent Clearances

For horizontal vent, maintain a minimum 1 inch clearance to the bottom and sides of the vent, and 3 inch clearance to combustibles above the vent pipe. See Figure 27.

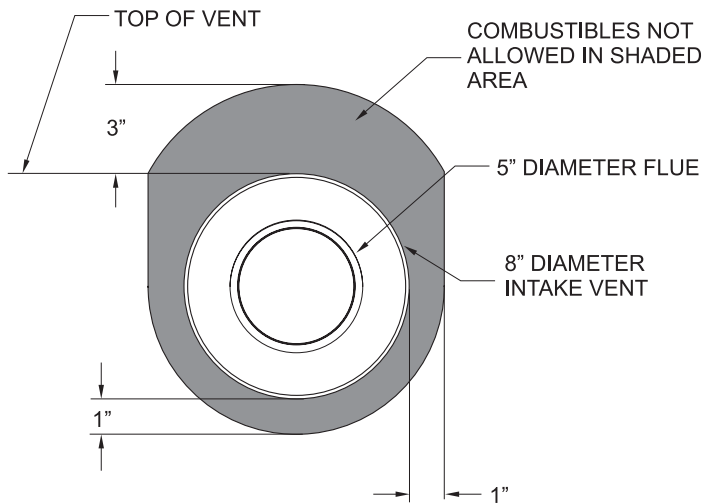


Figure 27

## 45° ELBOW WITH HORIZONTAL TERMINATION

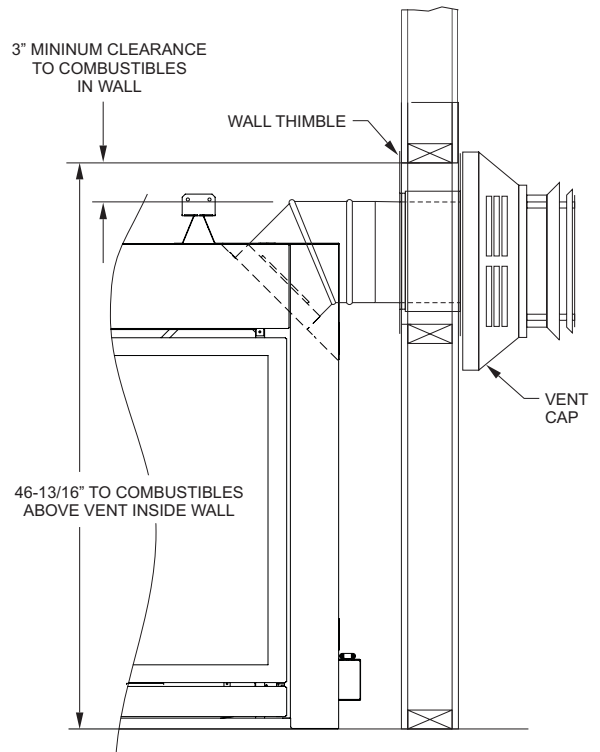
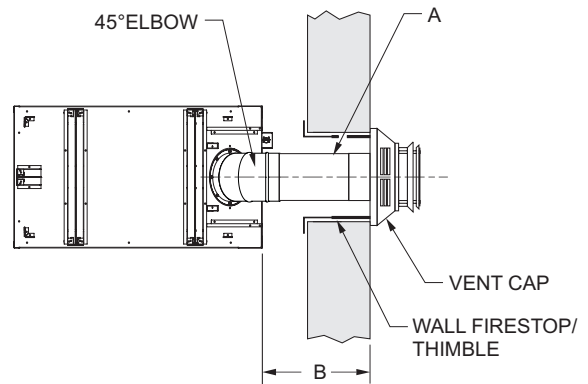


Figure 28



MINIMUM PIPE LENGTH (A)	FIREPLACE TO EXTERIOR WALL (B)
(Dimensions in inches)	
9	10-5/8
12	13-5/8
18	19-5/8
24	25-5/8

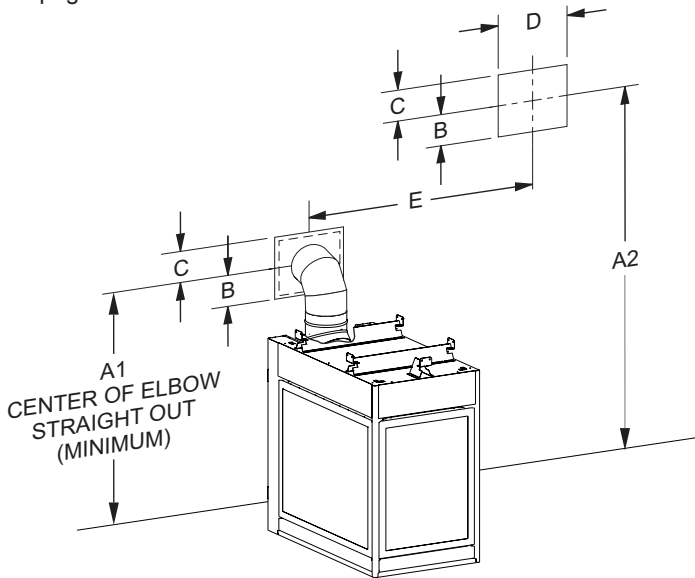
MAXIMUM REAR VENT RUN BY GAS TYPE		
PIPE LENGTH (A)	FIREPLACE TO EXTERIOR WALL (B)	GAS TYPE
(Dimensions in inches)		
84 (7ft)	84-5/8	NG
36 (3 ft)	36-5/8	LP

Figure 29

# INSTALLATION

## Cutting the Hole

After the fireplace has been positioned in its permanent location, the hole through the exterior wall of the house can be cut. This hole must be 12-5/8in high x 10-5/8in wide with its center line determined by the amount of vertical rise and horizontal run of the termination. **See Figure 30.** When locating the hole it must be noted that the bottom of the cap must be 12in above the ground level, and top of the cap must be no less than 18in below a combustible projection, and no closer than 9in to any wall running parallel to vent termination. Refer to "Below Grade Installation" on page 25.



DIMENSIONS (in inches)	
A1	49-5/8
B	5-5/16
C	7-5/16
D	10-5/8
E	See top vent configuration charts for allowable A2 and E dimensions, pages 28 and 29.
A2	

**MINIMUM HOLE LOCATION DIMENSIONS FOR THROUGH THE WALL INSTALLATIONS WITH 90 DEGREE ELBOW.**

**SEE FIGURE 41 ON PAGE 27 FOR PERMISSIBLE TOP VENT HORIZONTAL AND VERTICAL DIMENSIONS.**

Figure 30

## Installing Support Brackets

Install a horizontal pipe support used for each 3 feet of horizontal run to framing members. Allow 3 inches of clearance to combustibles above 8 inch diameter pipe and elbows and 1 inches of clearance on both sides and bottom.

Support vertical runs of this vent systems every 4 feet using wall brackets attached to the vent pipe and secured with nails or screws to structural framing.

**NOTICE:** Maintain all clearances to combustibles as shown in **Figures 6 to 8** on page 12.

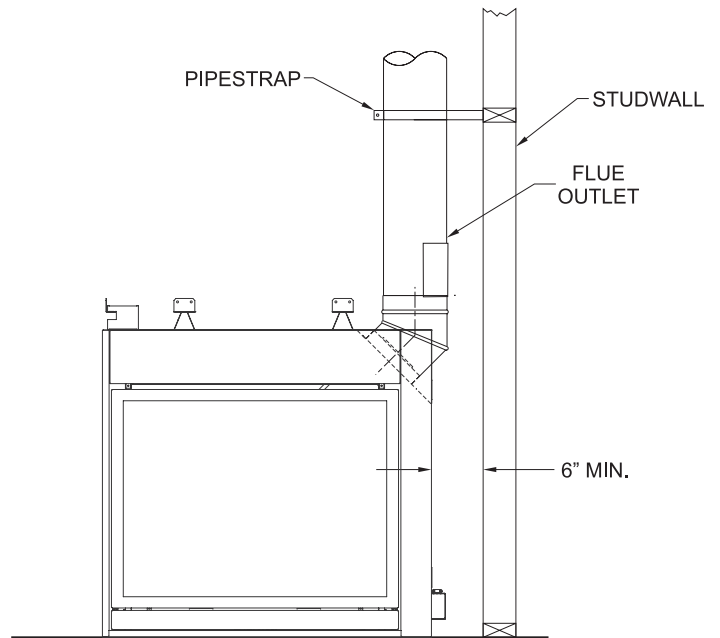


Figure 31

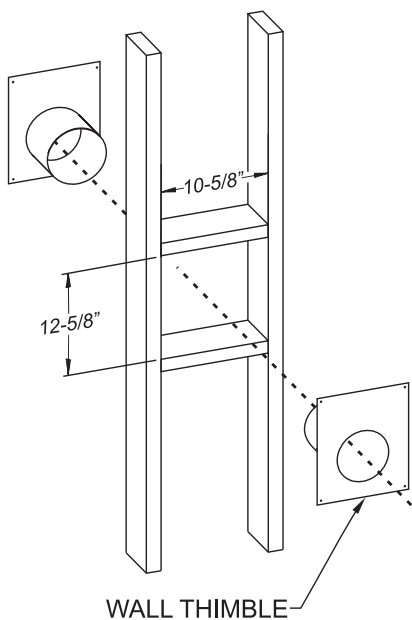
# INSTALLATION

## Installing Firestops

Firestops are required for safety whenever the vent system passes through an interior wall, an exterior wall, or a ceiling. These firestops act as a firebreak heat shield and as a means to insure that minimum clearances are maintained to the vent system.

## Horizontal Firestops

Horizontal runs in the vent system which pass through either interior or exterior walls, require the use of wall firestops on both sides of the wall through which the vent passes. Position the firestops on both sides of the framed hole, previously cut. Refer to **Figure 32** for sizing information. Secure firestop with nails or screws. The heat shields of the firestops **MUST BE** placed towards the top of the hole. Continue the vent run through the firestops.



**Figure 32**

**NOTICE:** SD58DVAWTEC Wall thimble is necessary to maintain the required three inches of clearance to combustibles above the vent. Framed hole dimensions shown above are for this wall thimble.

## Vertical Firestops

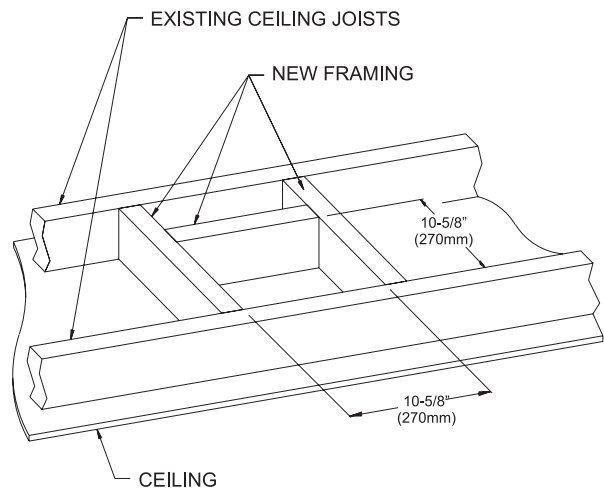
Vertical runs of this system which pass through ceilings require the use of ONE ceiling firestop at the hole in each ceiling through which the vent passes.

Position a plumb bob directly over the center of the vertical vent component and mark the ceiling to establish the center point of the vent. Drill a hole or drive a nail through this center point and check the floor above for any obstructions such as wiring or plumbing runs. Reposition the fireplace and vent system, if necessary, to accommodate ceiling joists and/or obstructions.

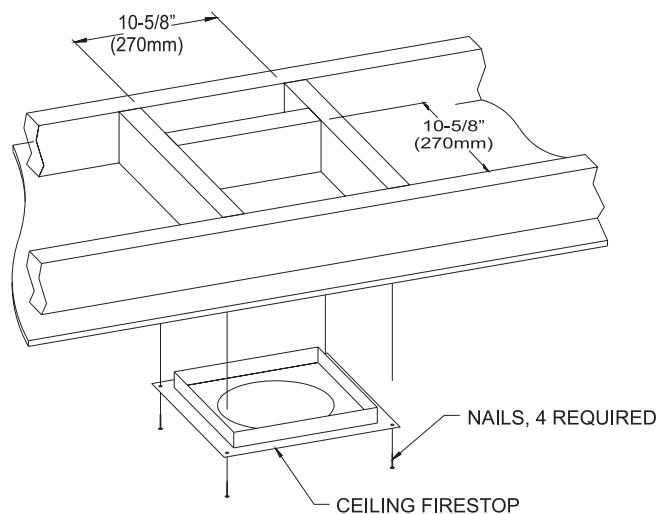
Cut a 10-5/8 inch x 10-5/8 inch hole (larger if within first 12-in of rise) through the ceiling, using the center point previously marked. Frame the hole with framing lumber the same size as the ceiling joists. **See Figure 33.** If the area above the ceiling is NOT an attic, position and secure the ceiling firestop on the ceiling side of the previously cut and framed hole. **See Figure 34.** If the area above the ceiling is an attic, position and secure the firestop on top of the previously framed hole. **See Figure 35.**

**NOTICE:** Remove insulation from the framed area in the attic before installing the firestop and/or vent pipes.

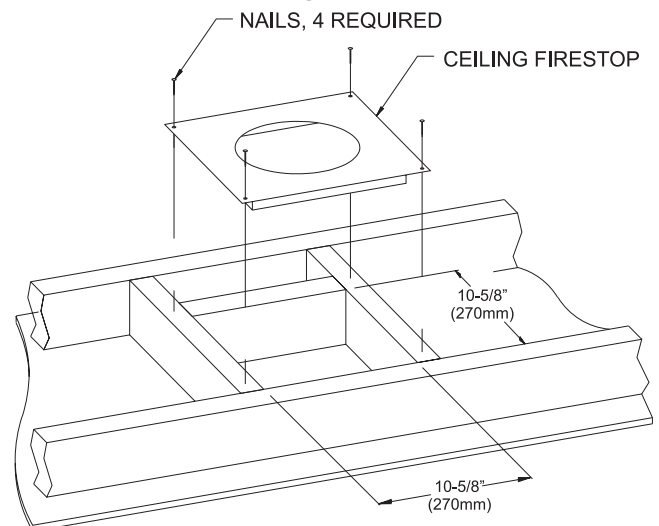
**NOTICE:** Prevent insulation from contacting pipe after it is installed.



**Figure 33**



**Figure 34**



**Figure 35**



# VENTING FIREPLACE - TOP (INITIAL 45° ELBOW ORIENTED UPWARDS)

## FLUE RESTRICTOR

**NOTICE:** For proper flame appearance, use flue restrictor for vertically terminated fireplaces. Do not use for horizontally terminated fireplaces.

Figures 36 to 38 show the location and recommended openings for the flue restrictor. The flue restrictor is recommended for use on vertical vent runs terminating 10ft from the floor or greater. Adjustments may be made for each particular installation.

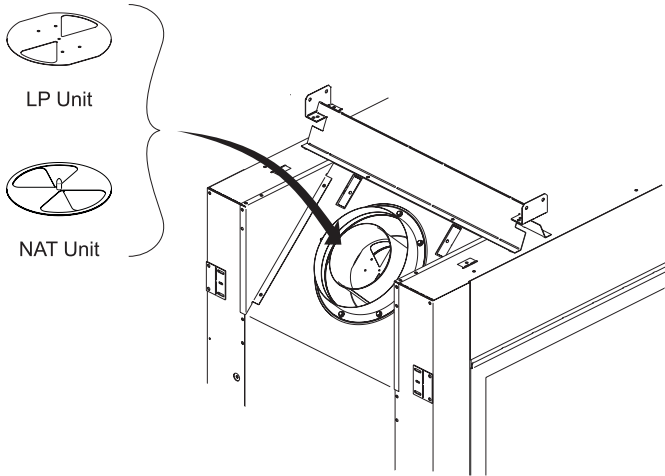
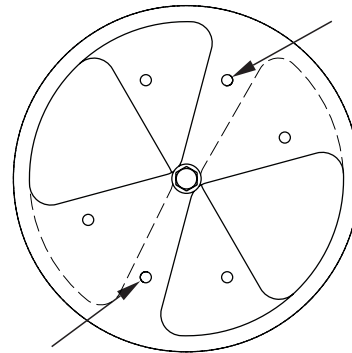
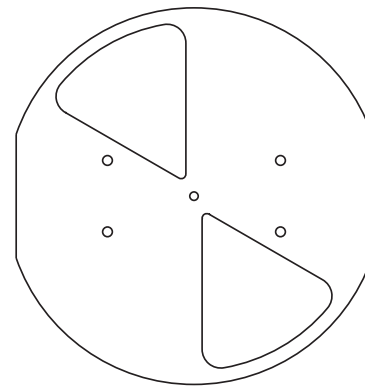


Figure 36

**NOTICE:** When installing NG flue restrictor, install with screws pointing in downward position.



Proper Setting of Natural Gas Flue Restrictor - Figure 37



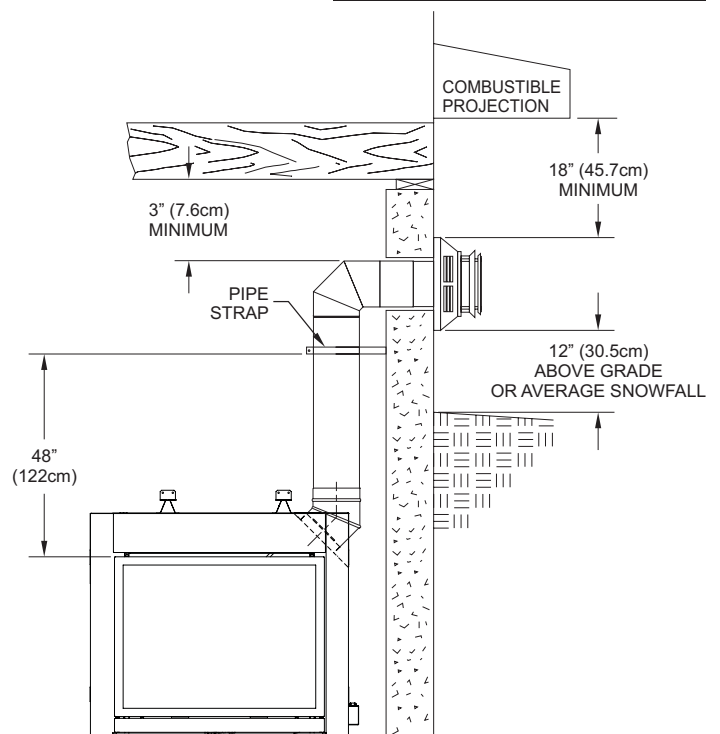
LP Flue Restrictor - Figure 38

## BELOW GRADE INSTALLATION

### Below Grade Installation

When it is not possible to meet the required vent termination clearances of 12 inches above grade level (or average snow fall), a snorkel kit is recommended. It allows installation depth down to 7 inches below grade level. The 7 inches are measured from the center of the horizontal vent pipe as it penetrates through the wall.

**Ensure the sidewall venting clearances are observed. If venting system is installed below ground, we recommend a window well with adequate and proper drainage to be installed around the termination area.**



TYPICAL BASEMENT INSTALLATION

Figure 39

# VENTING FIREPLACE - TOP

## TOP VENT SYSTEM IDENTIFICATION

Begin the vent system installation by selecting the type of venting to be installed and the path that it will take. Verify that clearances are met throughout the path of the venting system.

Determine how the vent system will be terminated out the side of the house or through the roof. Verify clearances for the termination.

When selecting a vent system for use with the fireplace, refer to the "Venting Fireplace" section in this manual to determine what systems are acceptable. Check all clearances and venting components. Identify problems existing in the vent system, if any. Use pages 27 to 34 for venting to eliminate issues after installation. Check pipe diameter on vent system and fireplace to verify the size is the same.

**NOTICE: All outer connection joints must be sealed with aluminum tape, screws or silicone sealant rated above 300°F/149°C. The inner flue joints do not require any sealant.**

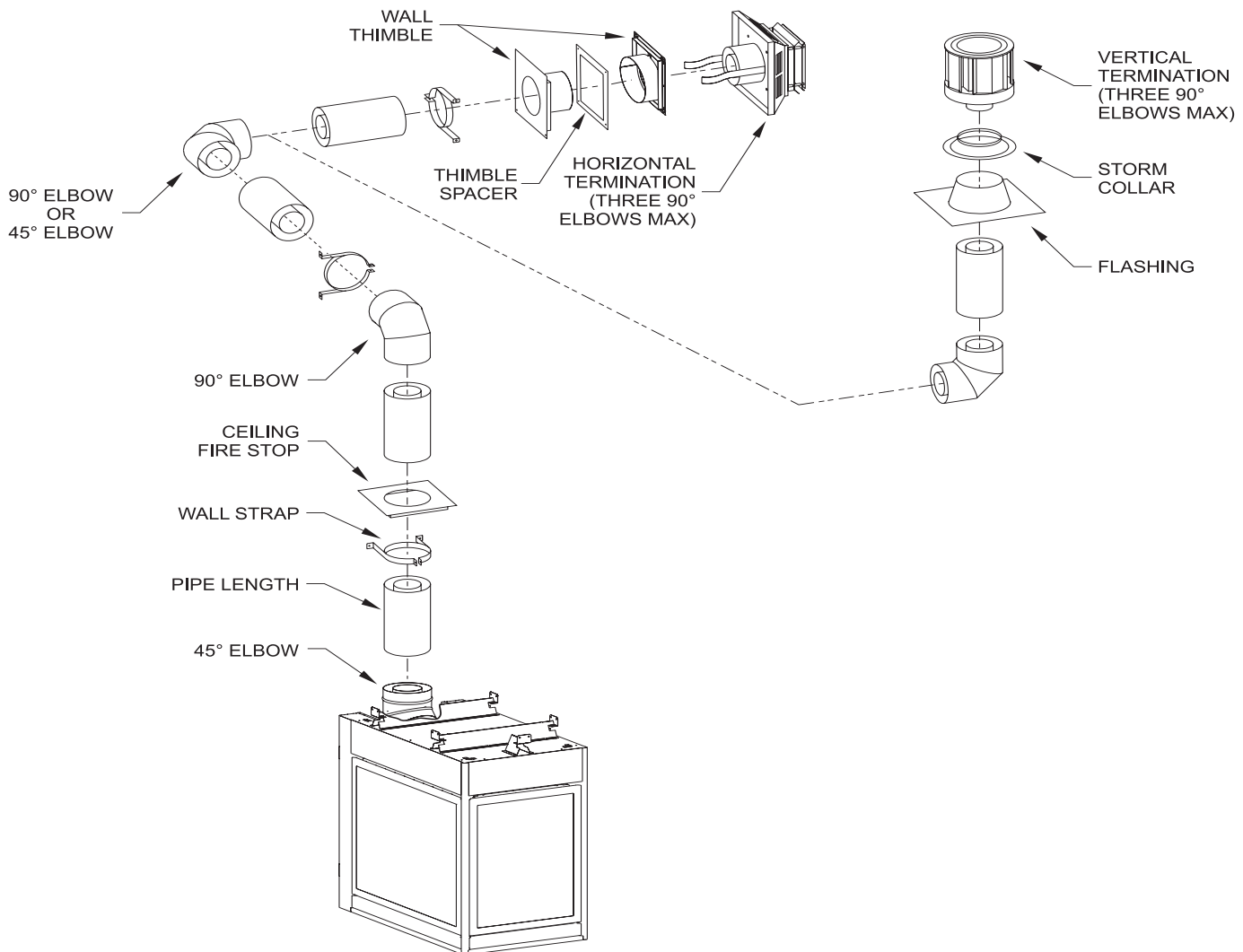


Figure 40

## VENT SYSTEMS

Use one of the following 5 x 8 vent systems:

- Simpson Duravent® GS
- American Metal Products
- Selkirk Direct-Temp®
- ICC
- Security Secure Vent
- Simpson Duravent - DVA-H2
- Empire Flex Vent Kit - DVVK-5F

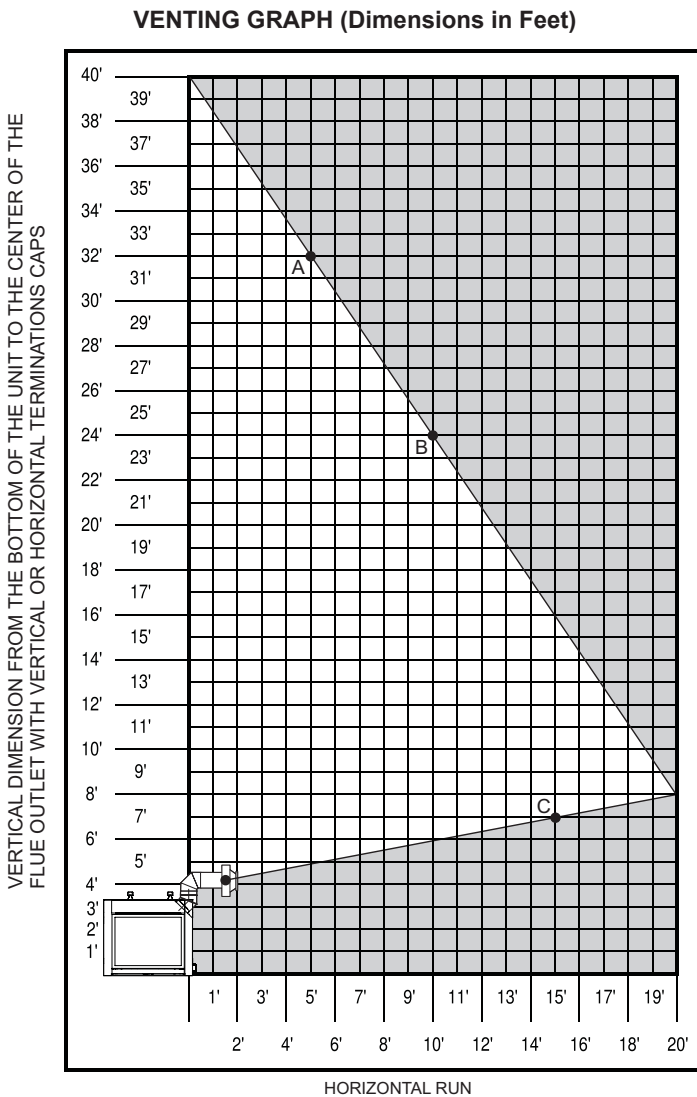
# VENTING FIREPLACE - TOP

## VENTING GRAPH

**NOTICE:** The initial 45° elbow is considered to be part of the fireplace and does not factor in the venting calculations.

### To Use the Vent Graph

1. Determine the height of the center of the horizontal vent pipe. Using this dimension on the Sidewall Vent Graph, locate the point it intersects with the slanted graph line.
2. From the point of this intersection, draw a vertical line to the bottom of the graph.
3. Select the indicated dimension, and position the fireplace in accordance with same.



**Figure 41**

### EXAMPLE A:

If the vertical dimension from the floor of the fireplace is 32 feet, the horizontal run to the outer wall flange must not exceed 5 feet.

### EXAMPLE B:

If the vertical dimension from the floor of the fireplace is 24 feet, the horizontal run to the outer wall flange must not exceed 10 feet.

### EXAMPLE C:

If the vertical dimension from the floor of the fireplace is 7 feet, the horizontal run to the outer wall flange must not exceed 15 feet.

**SPECIAL NOTICE:** For each 45° elbow installed in the horizontal run, the length of the horizontal run MUST be reduced by 18 inches. Reduce 3 feet for every 90° elbow. This does not apply if the 45° elbows are installed on the vertical part of the vent system.

**Example:** According to the chart the maximum horizontal vent length is 20 feet and if two 45° elbows are required in the horizontal vent it must be reduced to 17 feet.

The maximum number of 45° elbows permitted per side wall installation is two. These elbows can be installed in either the vertical or horizontal run.

**The maximum number of 90° elbows in a vent run is three.**

**NOTICE:** When figuring horizontal run length, the first elbow does not get counted. This is not referring to the initial 45° elbow which is considered to be part of the fireplace.

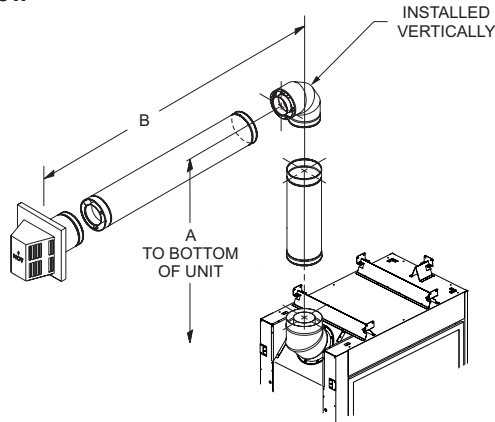
**NOTICE:** A horizontal vent with the minimum required vertical rise (using a 90° elbow directly on top of the initial 45° elbow) will use a maximum of a 9 inch section of horizontal vent before the termination.

- Acceptable vertical and horizontal vent run. (40ft maximum vertical and 20ft maximum horizontal)
- Unacceptable vertical and horizontal vent run.

# VENTING FIREPLACE - TOP

## HORIZONTAL TERMINATION

### One Elbow



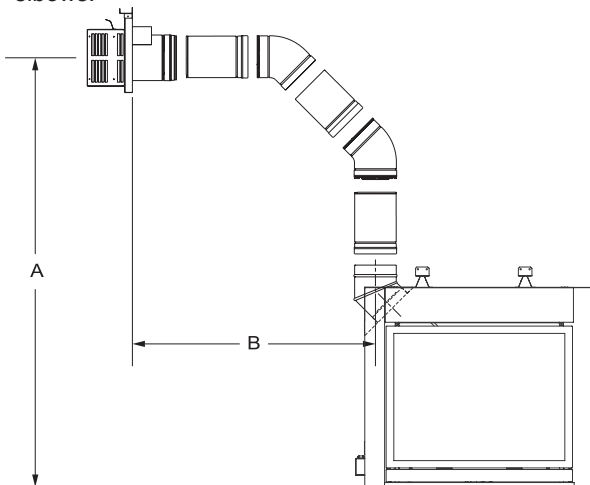
EXAMPLE VENT RUNS		
INITIAL PIPE LENGTH	A (Vertical)	B (Horizontal Maximum)
24in	6ft	10ft, 4in
36in	7ft	15ft
8ft	12ft	17ft, 8in
20ft	24ft	10ft

Figure 42

**NOTICE:** Pipe straps must be used every 2 feet to secure venting.

### Two 45° Elbows

Installation requirements to replace the first 90° elbow with two 45° elbows:

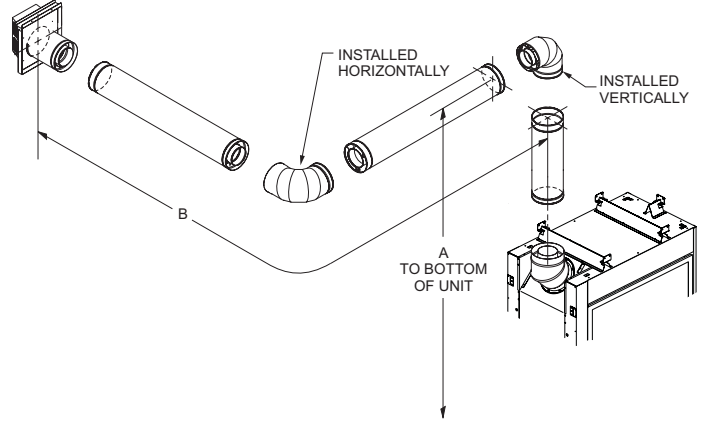


EXAMPLE VENT RUNS		
INITIAL PIPE LENGTH	A (Vertical)	B (Horizontal Maximum)
24in	6ft	10ft, 4in
36in	7ft	15ft
8ft	12ft	17ft, 8in
20ft	24ft	10ft

Figure 43

### Two Elbows

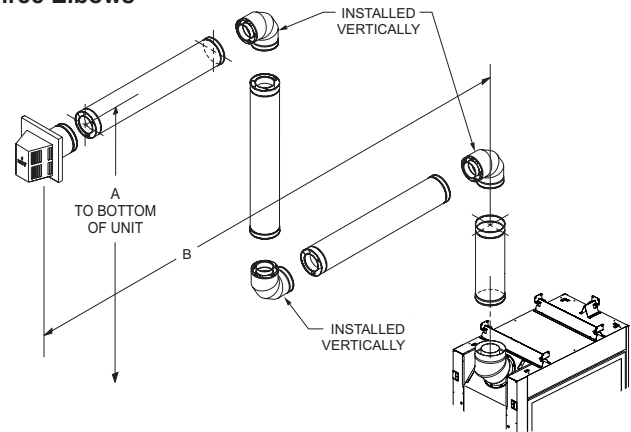
**NOTICE:** Subtract 3 feet from the total horizontal measurement for each 90° elbow installed horizontally. Subtract 1-1/2 feet from the total horizontal measurement for each 45° elbow installed horizontally.



EXAMPLE VENT RUNS		
INITIAL PIPE LENGTH	A (Vertical)	B (Horizontal Maximum)
36in	6ft	7ft, 4in
48in	7ft	12ft
8ft	12ft	14ft, 8in
20ft	24ft	7ft

Figure 44

### Three Elbows



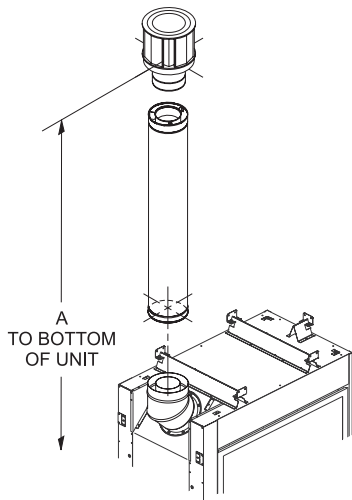
EXAMPLE VENT RUNS	
A (Vertical)	B (Horizontal Maximum)
6ft	10ft, 4in
7ft	15ft
12ft	17ft, 8in
24ft	10ft

Figure 45

# VENTING FIREPLACE - TOP

## VERTICAL TERMINATION

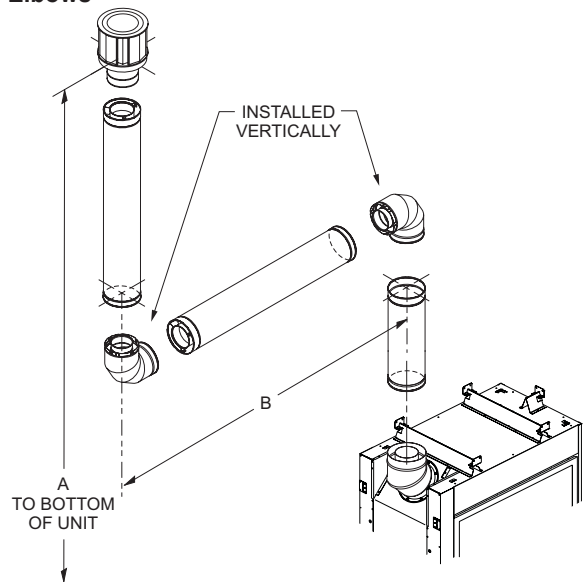
### No Elbows



DIMENSIONS	
MINIMUM	MAXIMUM
10ft	40ft

Figure 46

### Two Elbows

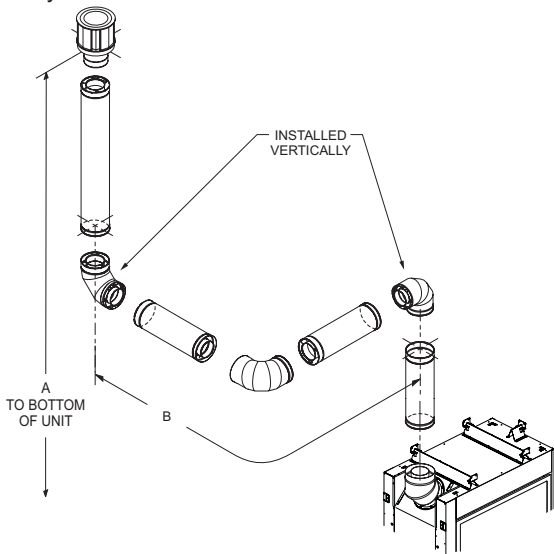


EXAMPLE VENT RUNS	
A (Vertical)	B (Horizontal Maximum)
6ft	10ft, 4in
7ft	15ft
12ft	17ft, 8in
24ft	10ft

Figure 48

### Three Elbows

**NOTICE:** Subtract 3 feet from the total horizontal measurement for each 90° elbow installed horizontally. Subtract 1-1/2 feet from the total horizontal measurement for each 45° elbow installed horizontally.



EXAMPLE VENT RUNS		
INITIAL PIPE LENGTH	A (Vertical)	B (Horizontal Maximum)
36in	6ft	7ft, 4in
48in	7ft	12ft
8ft	12ft	14ft, 8in
21ft	25ft	7ft

Figure 47

# VENTING FIREPLACE - TOP

## VERTICAL TERMINATION

Locate and mark the center point of the vent pipe using a nail on the underside of the roof. Drive the nail through the center point. Mark the outline of the roof hole around this center point.

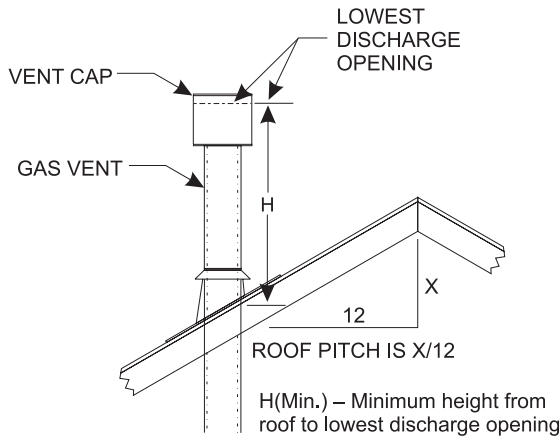
**NOTICE:** Size of the roof hole dimensions depend on the pitch of the roof. There must be a 1 inch clearance to the vertical pipe sections. This clearance is to all combustible material.

Cover the opening of the vent pipe and cut and frame the roof hole. Use framing lumber the same size as the roof rafters and install the frame securely. Flashing anchored to frame must withstand high winds. The storm collar is placed over this joint to make a water-tight seal. Appropriate sealant acceptable for temps up to 300°F should be used to completely seal this flashing installation.

### Determining Minimum Vent Height Above the Roof.

#### ⚠ WARNING

Major U.S. building codes specify minimum chimney and/or vent height above the roof top. These minimum heights are necessary in the interest of safety. These specifications are summarized in Figure 49.



ROOF PITCH	H (Min.)
	(Dimensions in Inches)
Flat to 6/12	12
6/12 to 7/12	15
Over 7/12 to 8/12	18
Over 8/12 to 16/12	24
Over 16/12 to 21/12	36

Figure 49

Note that for steep roof pitches, the vent height must be increased. In high wind conditions, nearby trees, adjoining roof lines, steep pitched roofs, and other similar factors can result in poor draft, or down-drafting. In these cases, increasing the vent height may solve this problem.

### General Maintenance

Inspect venting system semi-annually as follows:

1. Check for corrosion areas of the venting system exposed to the elements. These will appear as rust spots or streaks and, in extreme cases, holes. Replace damaged components immediately.
2. Remove the cap and shine a flashlight down the vent. Remove any bird nests or other foreign material.
3. Check for evidence of excessive condensate, such as water droplets forming in the inner liner and subsequently dripping out at joints. Condensate can cause corrosion of caps, pipe and fittings. It may be caused by having excessive lateral runs, too many elbows and exterior portions of the system being exposed to cold weather.
4. Inspect joints to verify that no pipe sections or fittings have been disturbed and, consequently, loosened. Also, check mechanical supports, such as wall straps or plumbers' tape for rigidity.

A removable panel or other means must be provided in the enclosure for visual inspection of the flue connection.

**NOTICE:** This also pertains to vertical vent systems installed on the outside of the building.

Slide the vertical vent cap over the ends of the vent pipe and secure. See Figure 50.

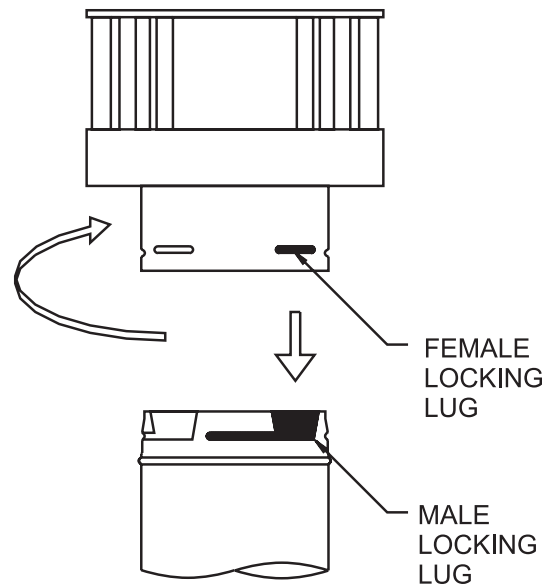


Figure 50

# VENTING FIREPLACE - TOP

## VERTICAL TERMINATION

### Installing the Vent System in a Chase

A chase is a vertical box-like structure built to enclose the gas fireplace and/or its vent system. Vertical vent runs on the outside of a building may be, but are not required to be installed inside a chase.

#### CAUTION

Treatment of firestop spacers and construction of the chase may vary with the type of building. These instructions are not substitutes for the requirements of local building codes. Check local building codes to determine the requirements for these steps. Improper installation of the fireplace can cause serious injury or death from fire, burns, explosions, or carbon monoxide poisoning.

**NOTICE:** Build the chase large enough to accommodate the minimum clearance of combustible materials (including insulation) to the vent system. When installing the vent system in a chase, insulate the chase as you would the outside walls of your home. This is especially important in cold climates. Upon completion of chase framing, install the vent system by following the instructions in this manual.

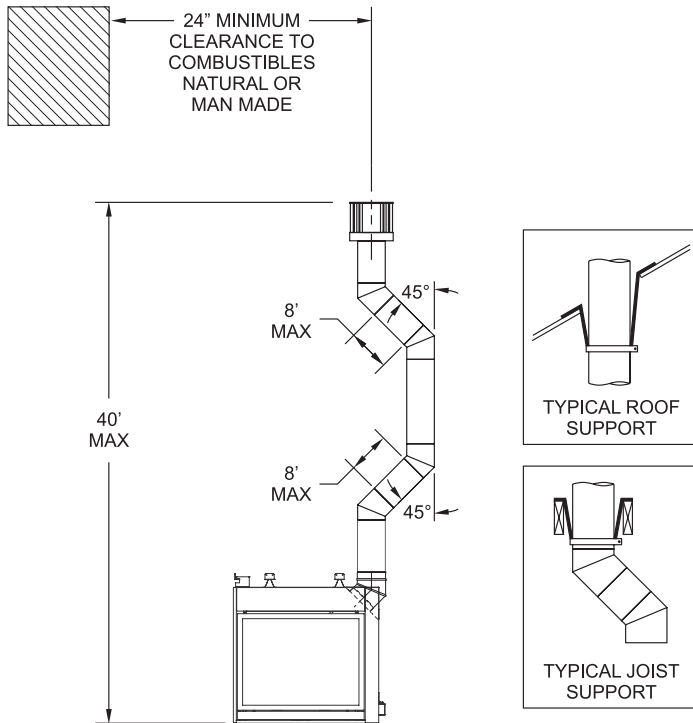


Figure 51

The vertical termination cap for this fireplace must not be any closer than 24in. to any other vent termination or chimney of any type.

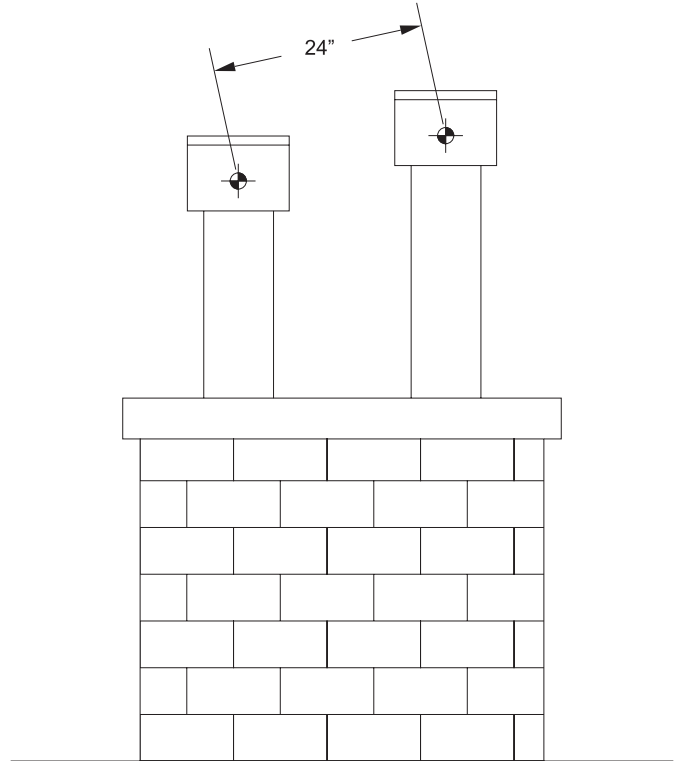


Figure 52

# VENTING FIREPLACE - TOP

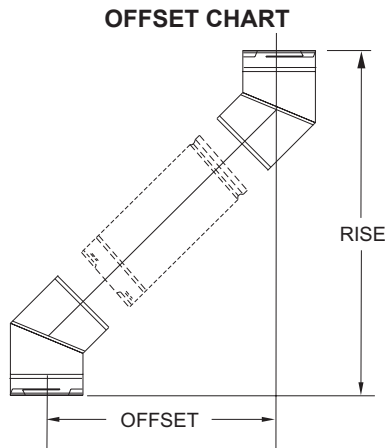
## VERTICAL TERMINATION

### Vertical Through the Roof Applications

Your Gas Fireplace has been approved for:

- a) Vertical installations up to 40 feet in height.
- b) Two sets of 45° elbow offsets within these vertical installations. A vent pipe from 0 to a maximum of 8 feet can be used between elbows.
- c) Wall straps must be used to support offset pipe every 4 feet

This application will require that you first determine the roof pitch and use the appropriate venting components.

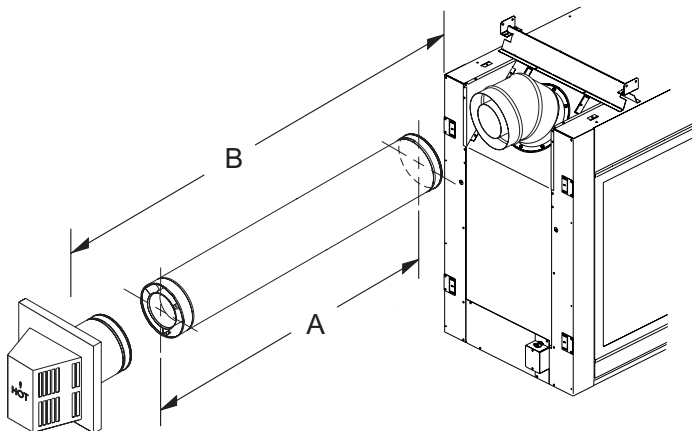


SIZE		5in X 8in	
ELBOW DEGREES	CHIMNEY SECTION	OFFSET INCHES	RISE INCHES
45°	0in	5-5/8in	15-3/8in
45°	6in	8-7/8in	18-3/8in
45°	9in	10-7/8in	20-5/8in
45°	12in	13in	22-5/8in
45°	24in	21-3/8in	31-1/8in
45°	36in	29-7/8in	39-3/8in
45°	36in	28-7/8in	39-3/8in
45°	48in	38-1/4in	47-7/8in

Figure 53

# VENTING FIREPLACE - REAR

No Elbow



PIPE LENGTH (A)	FIREPLACE TO EXTERIOR WALL (B)
DIMENSIONS IN INCHES	
9	9-5/8
12 (1ft)	12-5/8
18 (1ft, 6in)	18-5/8
24 (2ft)	24-5/8

MAXIMUM REAR VENT RUN BY GAS TYPE		
PIPE LENGTH (A)	FIREPLACE TO EXTERIOR WALL (B)	GAS TYPE
DIMENSIONS IN INCHES		
84 (7ft)	84-5/8	NG
36 (3 ft)	36-5/8	LP

Figure 54



# DVVK-5F FLEX VENT INSTRUCTIONS

The **DVVK-5F FLEX VENT KIT** includes the following components:

- (1) Horizontal Termination Cap
- (1) 4-foot section of Flex vent with spacers (5in flue/8in outer pipe) with flue adapter collar
- (1) Wall Firestop/Thimble Assembly
- Hardware pack that includes band clamps and screws

Maintain at least 1/2 inch rise for every 12 inches of vent run.

## ⚠ CAUTION

- Because of sharp edges, always use gloves when handling the flex vent components.
- Always follow the general venting requirements for vent terminal location, vent lengths, and clearance to combustible materials.
- If space permits, it is generally easier to attach venting in the top vent configuration.
- Always stretch and secure venting with wire or metal strapping to ensure that the horizontal runs do not sag.
- Vent connections should overlap a minimum of 1in for proper sealing.

## INSTALLATION

1. Unpack vent components and check that all items are included.
2. Check to see that the vent spacer springs are located around the flue vent at 8in intervals along its length. See **Figures 55 & 56**. If not, stretch the spacer springs to about 15in long and wrap them around the flue, then interlock the ends of each spring. Maintain equal distance between spring spacers.

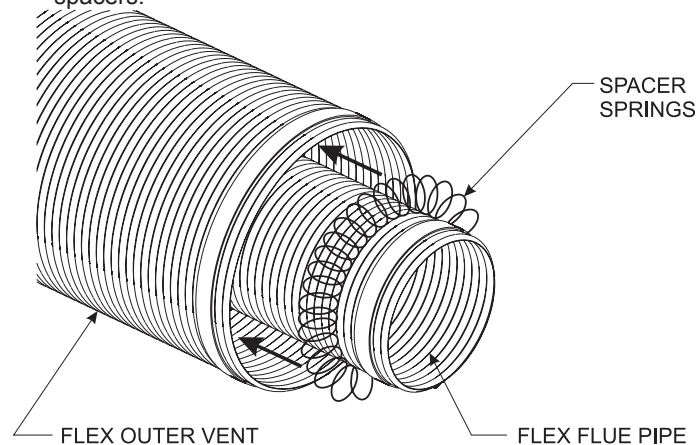


Figure 55

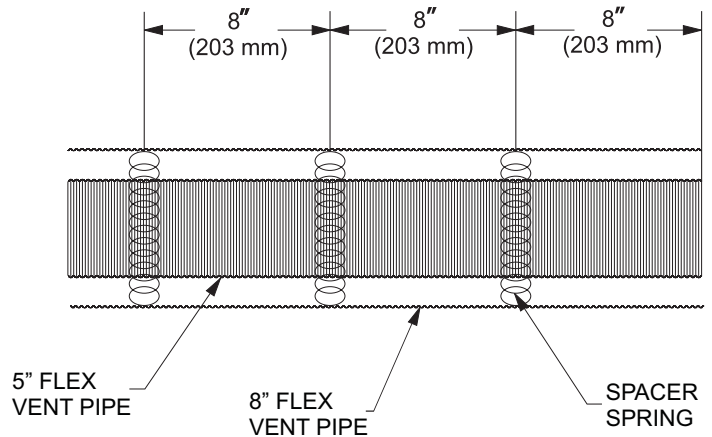


Figure 56

3. Attach a 6in piece of hard pipe to raise the connection point above the fireplace.
4. Use existing 8in diameter inlet collar to attach outer vent pipe.
5. Install the Wall Firestop/Thimble assembly as required through the wall. Refer to the venting charts in the fireplace manual to determine the proper height and size of the vent opening. The minimum opening should be 10in wide by 12in high. The minimum combustible clearance from the horizontal vent is 1in from sides and bottom, and 3in above the vent pipe. See **Figure 57**.
6. In most cases, after determining the length of the vent that is needed, it may be easier to install the flue and outer vent pipes to the Termination Cap first, then from the outside, feed the venting through the wall to the fireplace.
7. If the venting is to long, trim off any excess vent before attaching the vent end connectors.
8. Attach the Termination Cap to the outside of the house.

## ⚠ CAUTION

Do not use force when installing the Horizontal Vent Termination into the flex venting. Always stretch venting out first, then cut off excessive vent material prior to sliding the vent termination into the flue and inlet venting. Forcing the termination cap into the flex venting will deform the flue venting, which will restrict the exhaust gases, and cause improper operation of the fireplace.

# DVVK-5F FLEX VENT INSTRUCTIONS

9. Prior to making the vent connections, apply high temperature sealant (1000°F min.) to the vent connections before securing with the band clamps provided. **NOTICE:** the flue pipe end without the adapter is to be installed to the Termination Cap.
10. Apply sealant to the outside of the flue pipe adapter and connect to the flex flue pipe. Then insert the adapter into the 45° elbow's inner flue pipe. Secure flue adapter with a minimum of two screws provided. **See Figure 57.**
11. Attach the Outer Vent pipe to the 45° elbow with a large band clamp provided. Sealant may also be used on the outer vent connections.
12. Check all vent connections for tightness. Make sure horizontal venting has the proper rise and combustible clearances required. Refer to venting charts in fireplace instruction manual.

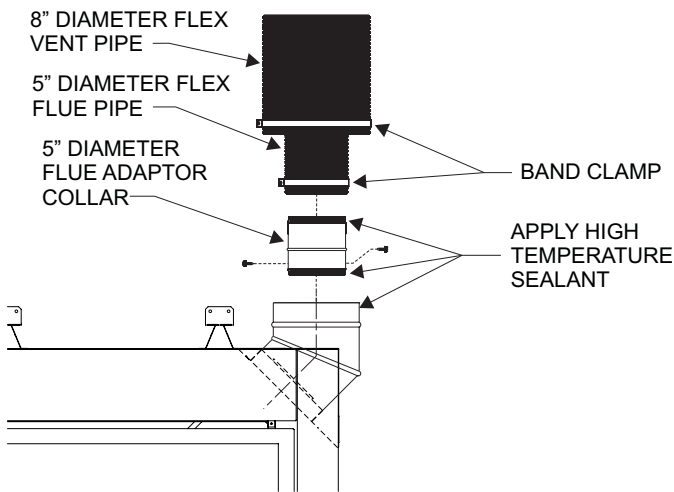


Figure 57

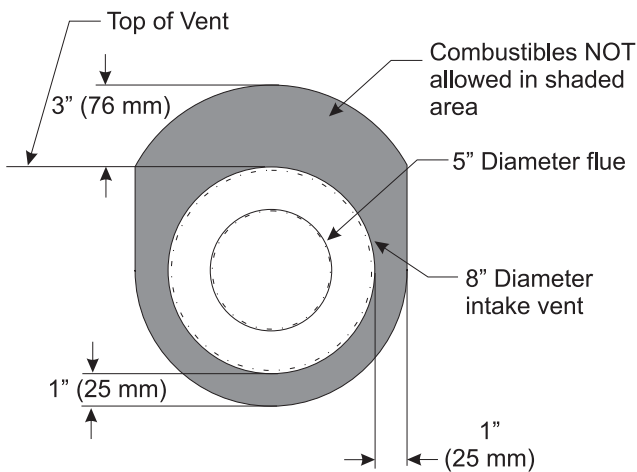


Figure 58

# FINISHING INSTALLATION

Use non-combustible materials where indicated for the fireplace installation. Non-combustible materials do not ignite or burn as a result of using the fireplace. These include metal, brick, ceramic, concrete, slate, glass and plaster. Adhesives must be rated for high temperatures. Any mechanical fasteners used to install material must also be non-combustible, including wall anchors and tile spacers. Materials that pass the ASTM E 136 test (Standard Test Method for Behavior of Materials in a Vertical Tube Furnace at 750C) are considered non-combustible.

**Figures 6 - 9** on Pages 12 and 13 shows the minimum vertical and corresponding maximum horizontal dimensions of mantels and other combustible projections above the top front edge of the fireplace.

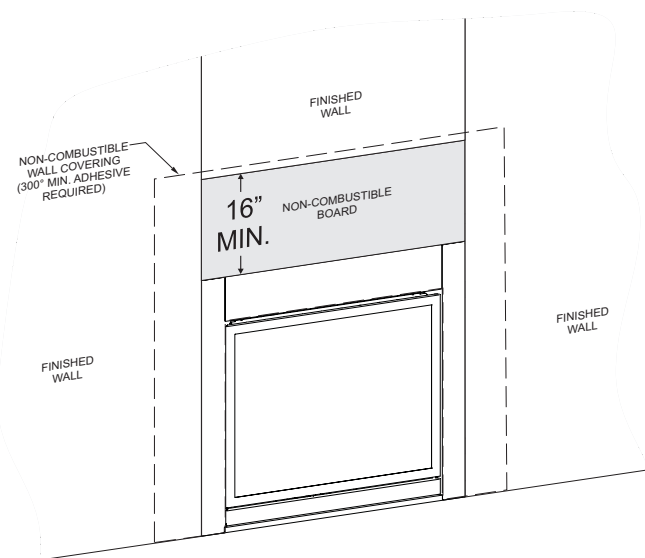
Only non-combustible materials may be used to cover the black fireplace front.

## **⚠ WARNING**

**When finishing the fireplace never obstruct or modify the air inlet/outlet louvers in any manner. Provide adequate clearances around air openings into the combustion chamber.**

## **⚠ CAUTION**

**If the joints between the finished wall and the fireplace surround (top and sides) are sealed, a 300 Degree F minimum sealant material must be used. These joints are not required to be sealed. Only non-combustible material (using 300 Degree F minimum adhesive if needed), can be applied as facing to the fireplace surround.**



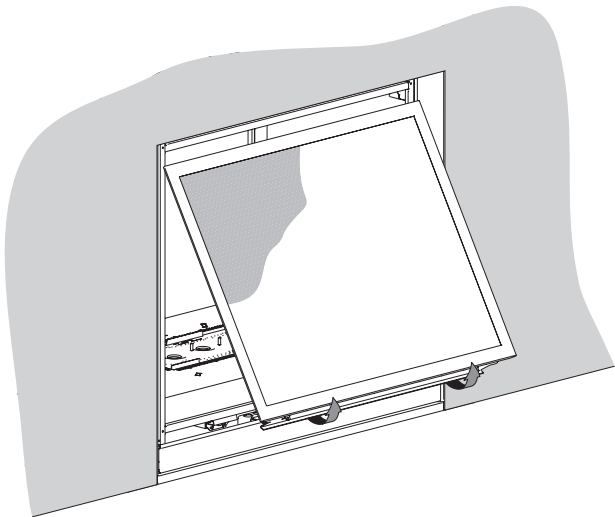
**Figure 59**

# OPTIONAL FIBER OR PORCELAIN LINERS

Liners are not required for this fireplace, but add to the ambience. Order one liner for a peninsula and two for a see-through.

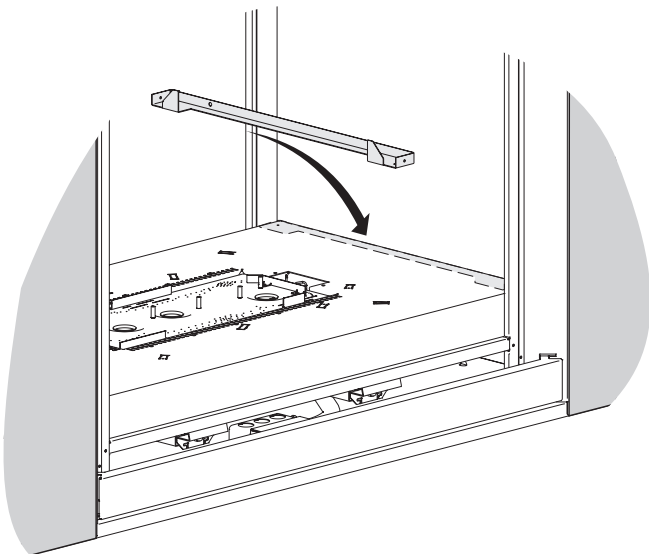
**NOTICE:**

- This sequence may be used to install liners into either side of the firebox.
  - The fiber or porcelain liner(s) must be installed prior to installing the log set on the burner.
  - The fiber or porcelain liners sit in front (NOT behind) of the brick brackets as shown in **Figures 61 and 62**.
1. From either side of the fireplace, remove the lower access panel.
  2. The two glass spring-latches are on the bottom of the glass frame. Release them by pulling them away from the fireplace and down. Remove the screen frame and glass frame as a unit (separating them is not necessary) by lifting them up and away from the fireplace. **See Figure 60.**



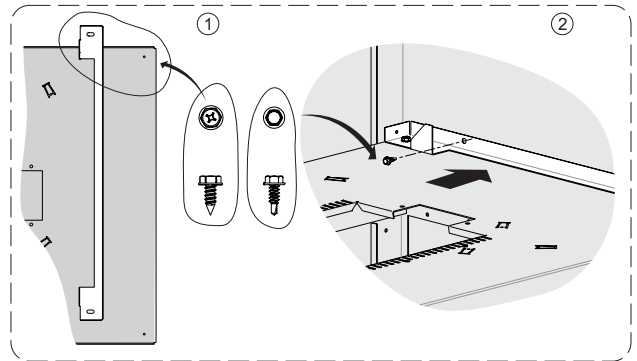
**Figure 60**

3. Set the brick bracket against the firebox wall as shown in **Figure 61**.



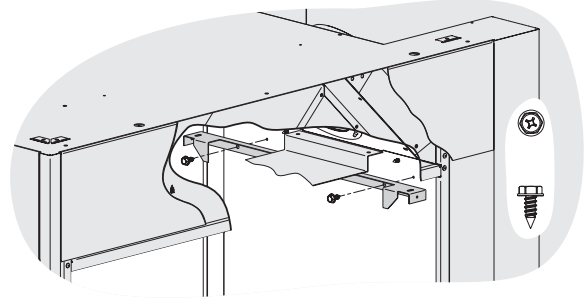
**Figure 61**

4. Screw the brick bracket to the false floor (but do not tighten) with the screws shown on the left side of **Figure 62** (Vent / Pilot side liner only).
5. Use the self-drilling screws shown on the right side of **Figure 62** to attach the brick bracket to the firebox wall.



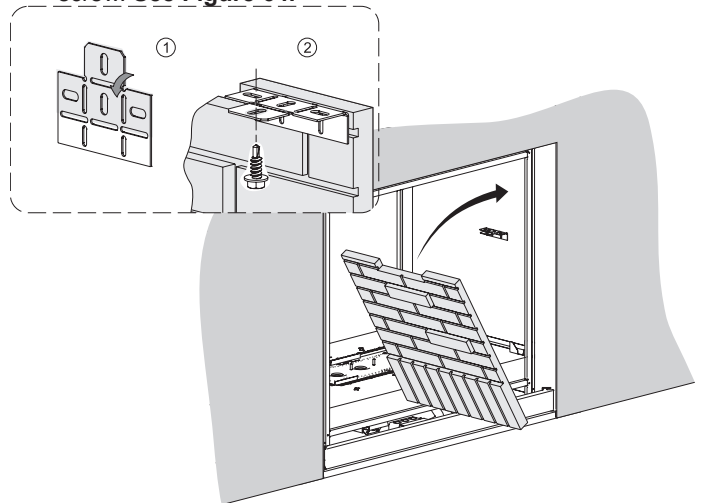
**Figure 62**

6. Tighten the screws installed in step 4. (Vent / Pilot side liner only).
7. Attach a second brick bracket to the top of the firebox wall using two sheet metal screws as shown in **Figure 63**.



**Figure 63**

8. Set the bottom edge of the fiber or porcelain liner in front of the bottom brick bracket (not behind) and tilt it into place against the top brick bracket. **See Figure 64.**
9. Secure the fiber or porcelain liner in place using the remaining hand-formed retaining bracket. Form the bracket as shown and fasten it to the firebox top using a self-drilling screw. **See Figure 64.**



**Figure 64**

# GLOWING EMBERS

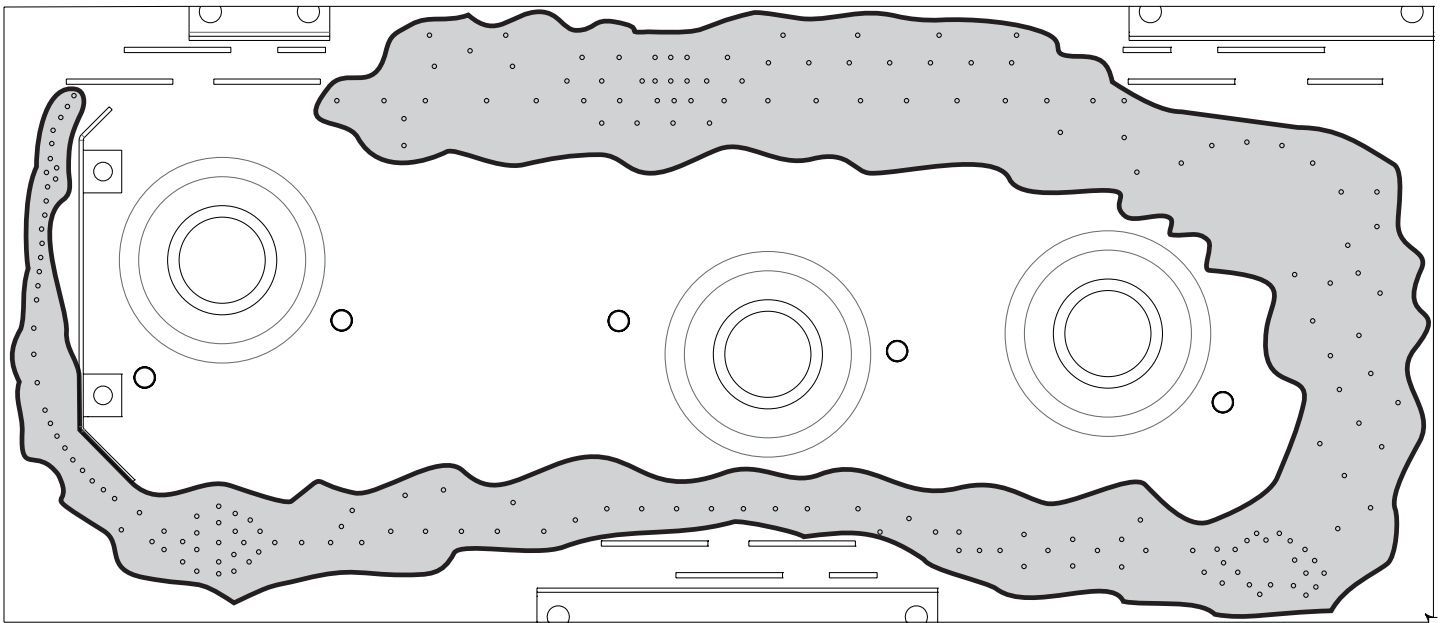
Install embers after installing the false floor of the fireplace, and before the logs. Refer to the instruction manual supplied with your Log Set or Mixed Log and Stones kit. Apply a single layer of small "dime-sized" pieces of rock wool (glowing embers) in the shaded areas shown below.

**NOTICE:**

- Pieces of glowing embers should be fluffed up prior to placement onto the burner.
- Replacement of loose material (glowing embers) must be purchased from an Empire Comfort Systems Dealer.
- Application of excess loose material (glowing embers) may adversely affect performance of the fireplace. A single layer of embers is to be used when applying Platinum Bright Embers (in combination with production embers) to the burner.























**⚠ WARNING**

**All previously applied loose material must be removed prior to reapplication.**



**TOP View - Ember Placement Shown in Shaded Area  
Figure 65**

# LOG IDENTIFICATION - LSU24SPF

DESCRIPTION	PART NO.	FRONT VIEW	TOP VIEW
Log A	36018		
Log B	36019		
Log C	36027		
Log D	36025		
Log E	36021		
Log F	36023		
Log G	36020		
Log H	36028		
Log I	36022		
Log J	36026		
Log K	36024		

**Attention:** When ordering parts, it is very important that **part number** and **description** coincide.

# LOG PLACEMENT - LSU24SPF

Before you begin: Do not, handle these logs with your bare hands! Always wear gloves to prevent skin irritation. After handling logs, wash your hands gently with soap and water.

## All Logs

The positioning of the logs is critical to the safe and clean operation of this fireplace. Sooting and other problems may result if the logs are not properly and firmly positioned in the fireplace.

Refer to Figure 66 for the following warning.

### ⚠ WARNING

Failure to position the parts in accordance with this diagram or failure to use only parts specifically approved with this fireplace may result in property damage or personal injury.

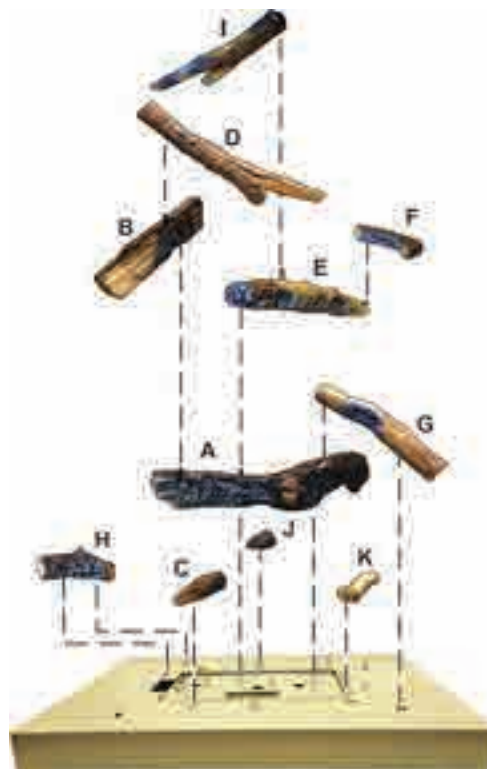
Attention: Do not use Figure 66 to order replacement logs. Refer to Page 38 Log Identification to order logs for your appropriate model number

**NOTICE:** Once the installation is complete with the glowing embers and log set in place, operate the fireplace to verify flame appearance. If there are flames directly impinging a log, turn off fireplace, then remove the glowing ember material directly below where the flame impingement occurred. This should eliminate sooting on the log, and provide a more pleasing flame appearance.

Replacement of glowing embers must be purchased from an Empire Comfort Systems Dealer. Application of excess glowing embers may adversely affect performance of the fireplace.

### ⚠ WARNING

All previously applied loose material must be removed prior to reapplication.

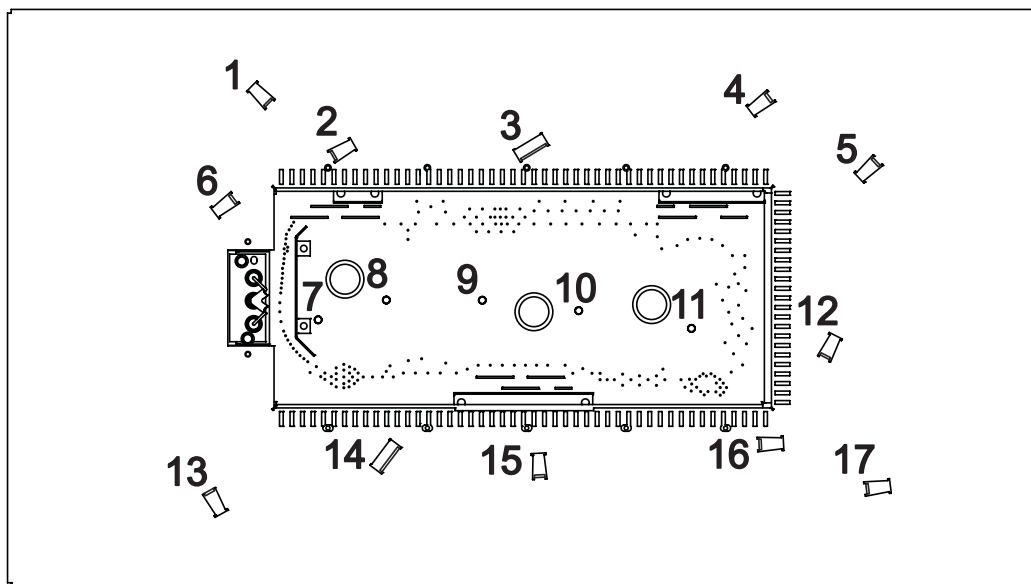


Log Placement Figure 66

FRONT VIEW - COMPLETED LOG SET INSTALLATION (WITHOUT EMBERS)



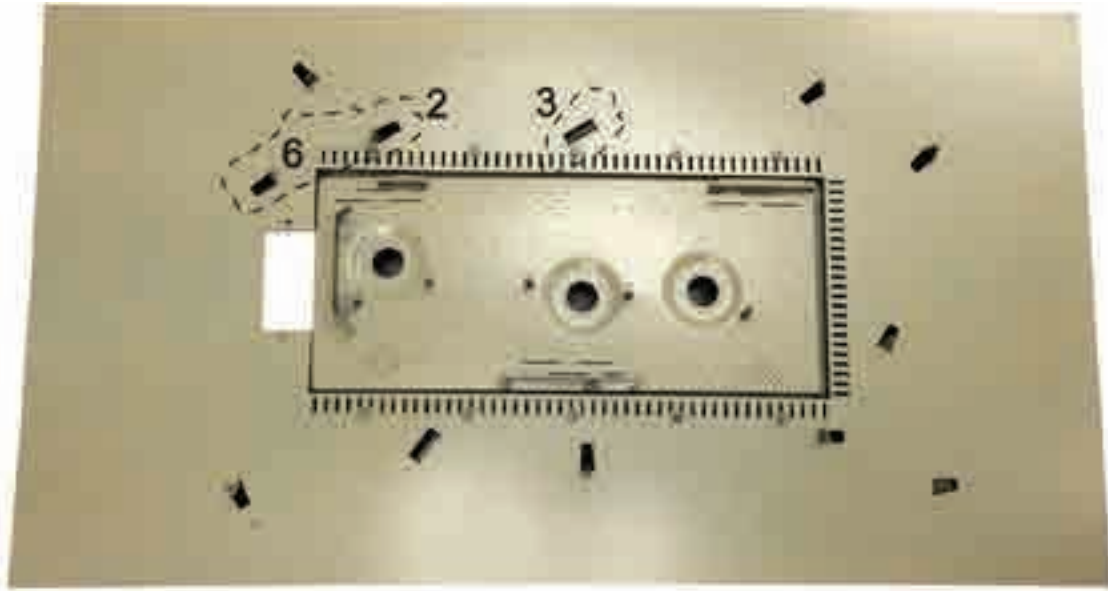
Figure 67



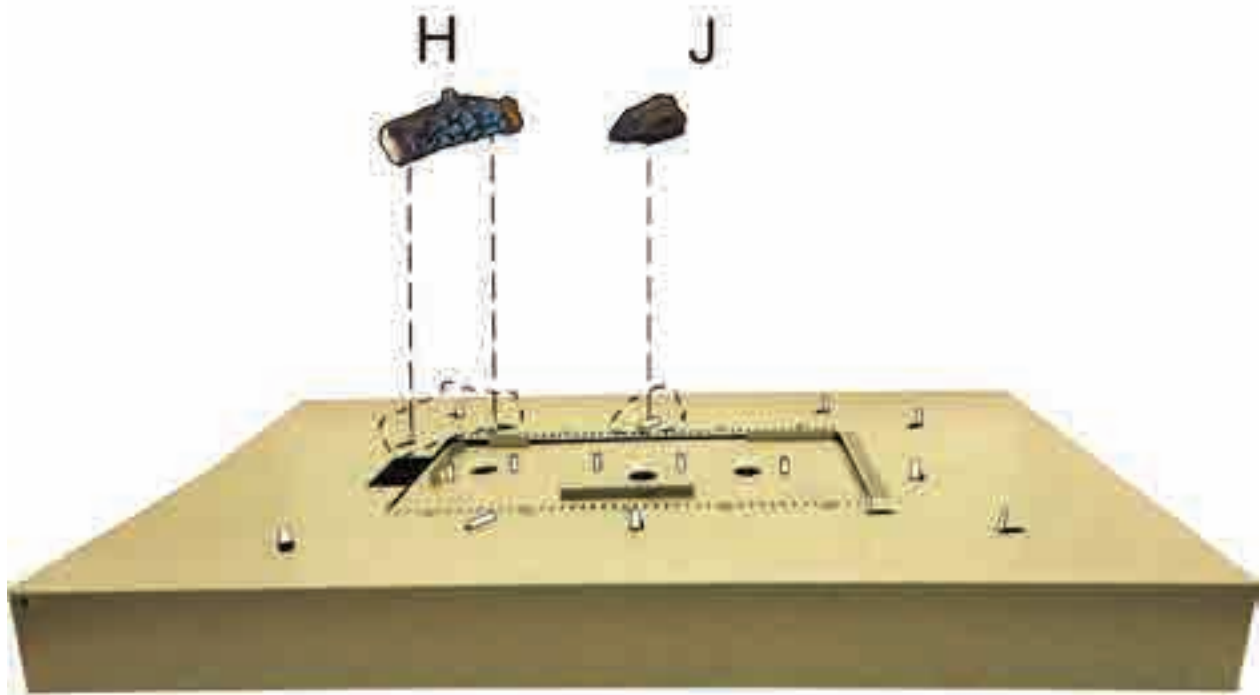
Burner Pin and Tab Identification - Figure 68

# LOG PLACEMENT - LSU24SPF

1. Place Log H on to burner tabs 6 and 2. Place Log J onto burner tab 3. Refer to the images on this page.



Top View

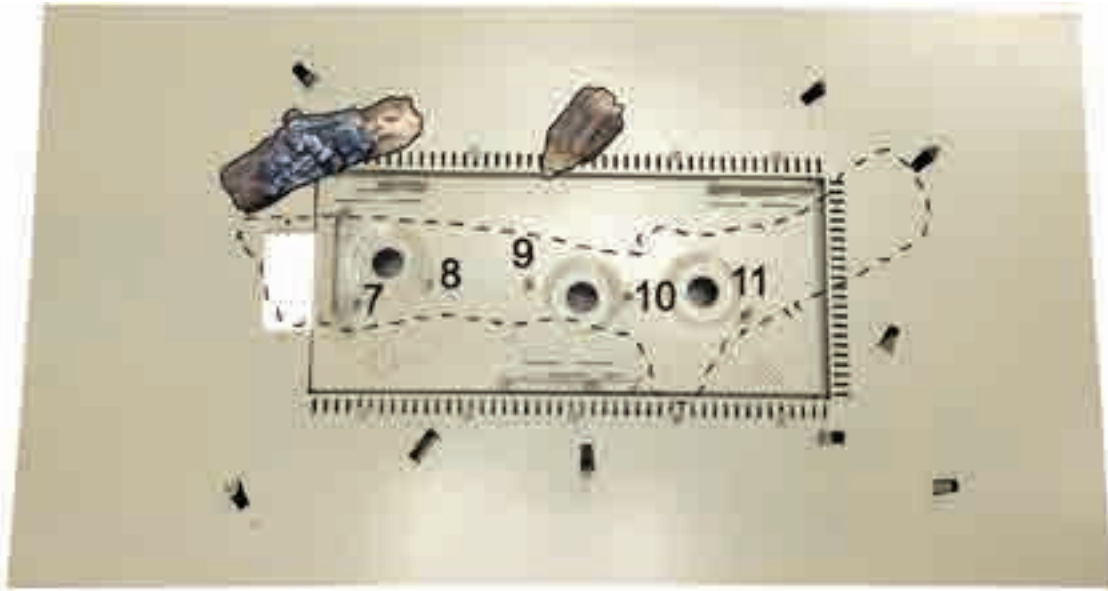


Front View

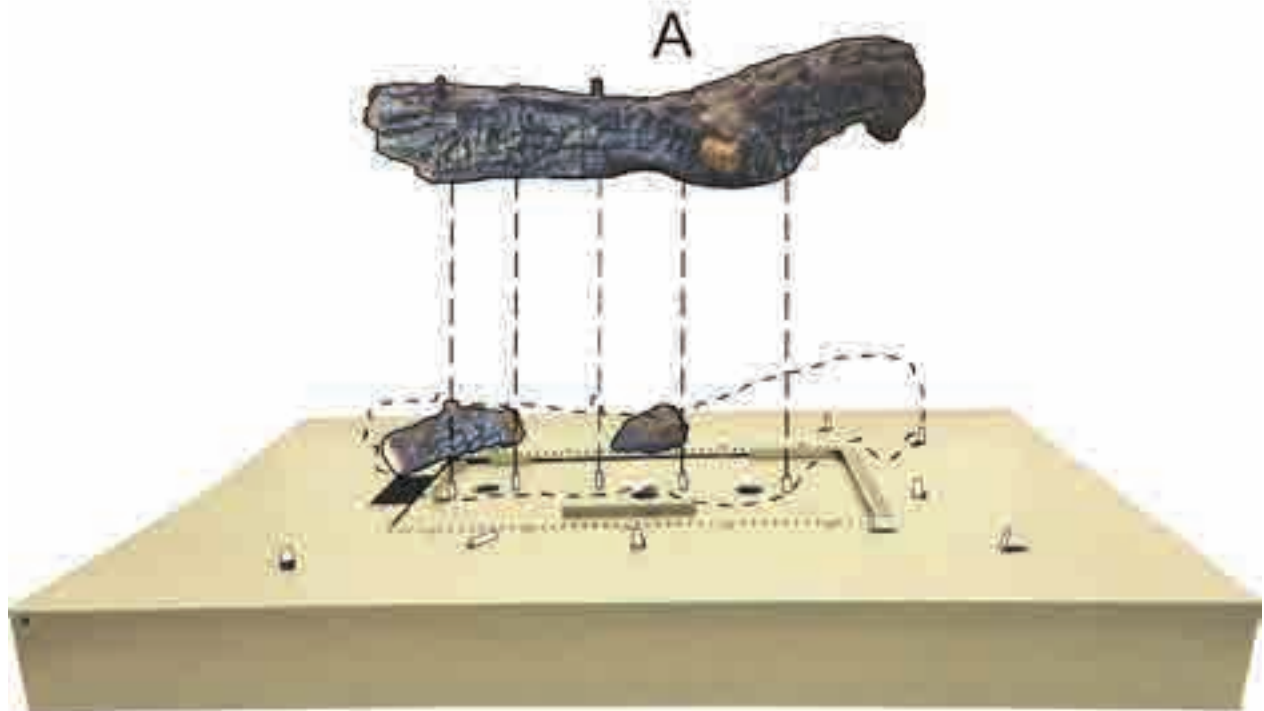


# LOG PLACEMENT - LSU24SPF

2. Place Log A on to burner pins 7, 8, 9, 10 and 11. Refer to the images on this page.



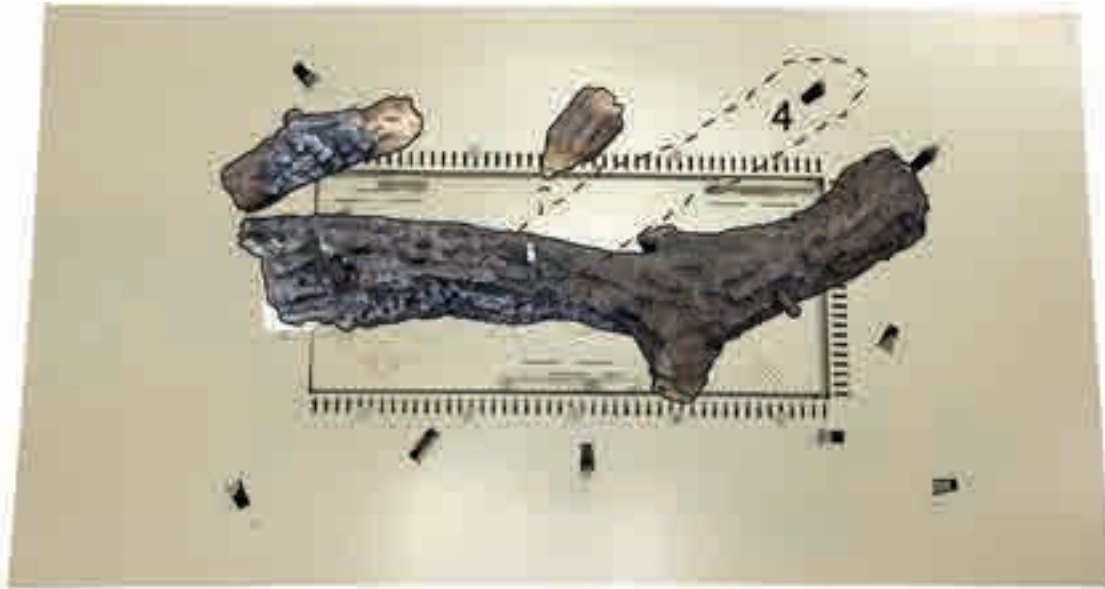
Top View



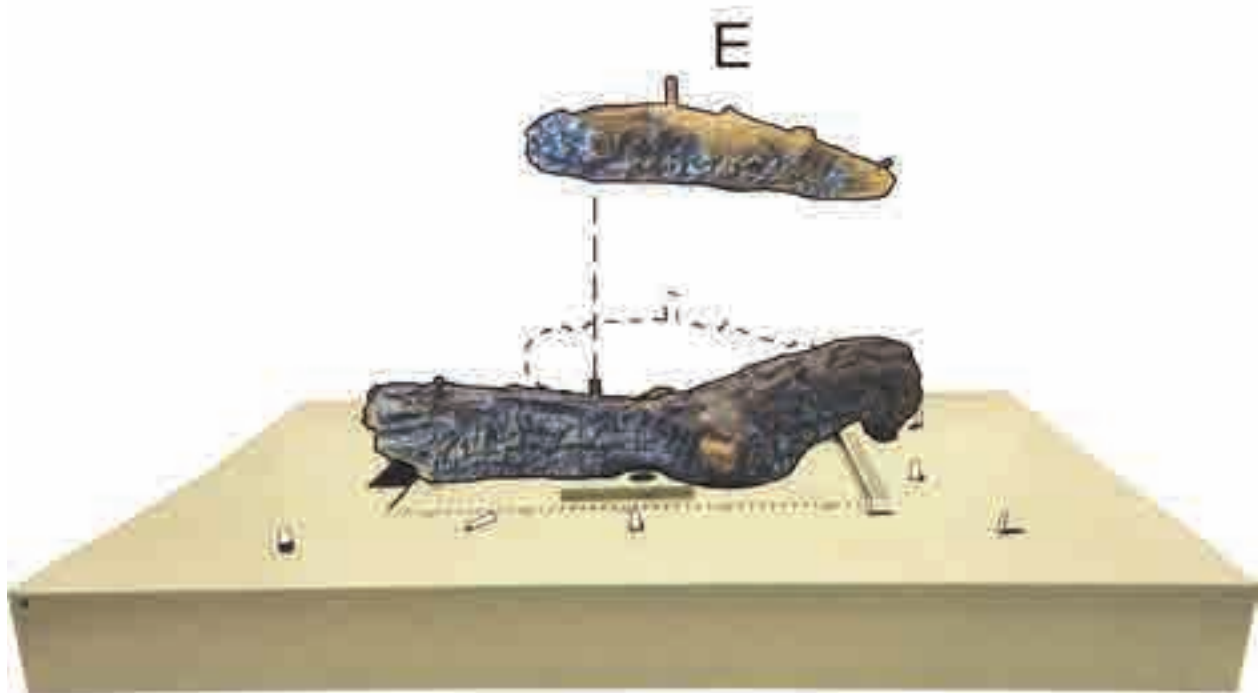
Front View

# LOG PLACEMENT - LSU24SPF

3. Place Log E onto burner tab 4 and the pin on Log A. Refer to the images on this page.



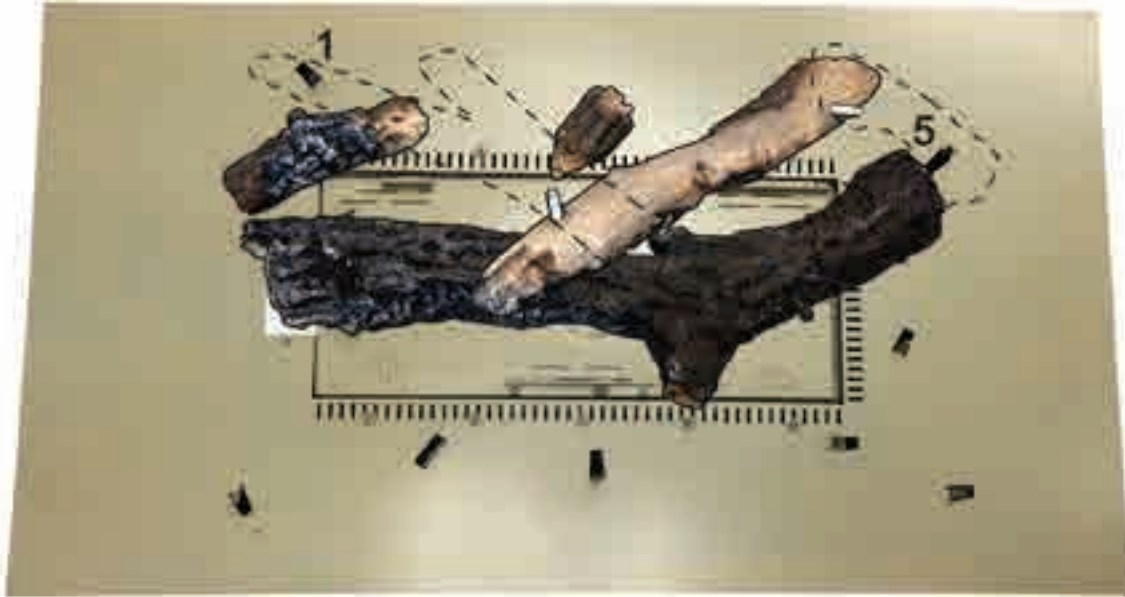
Top View



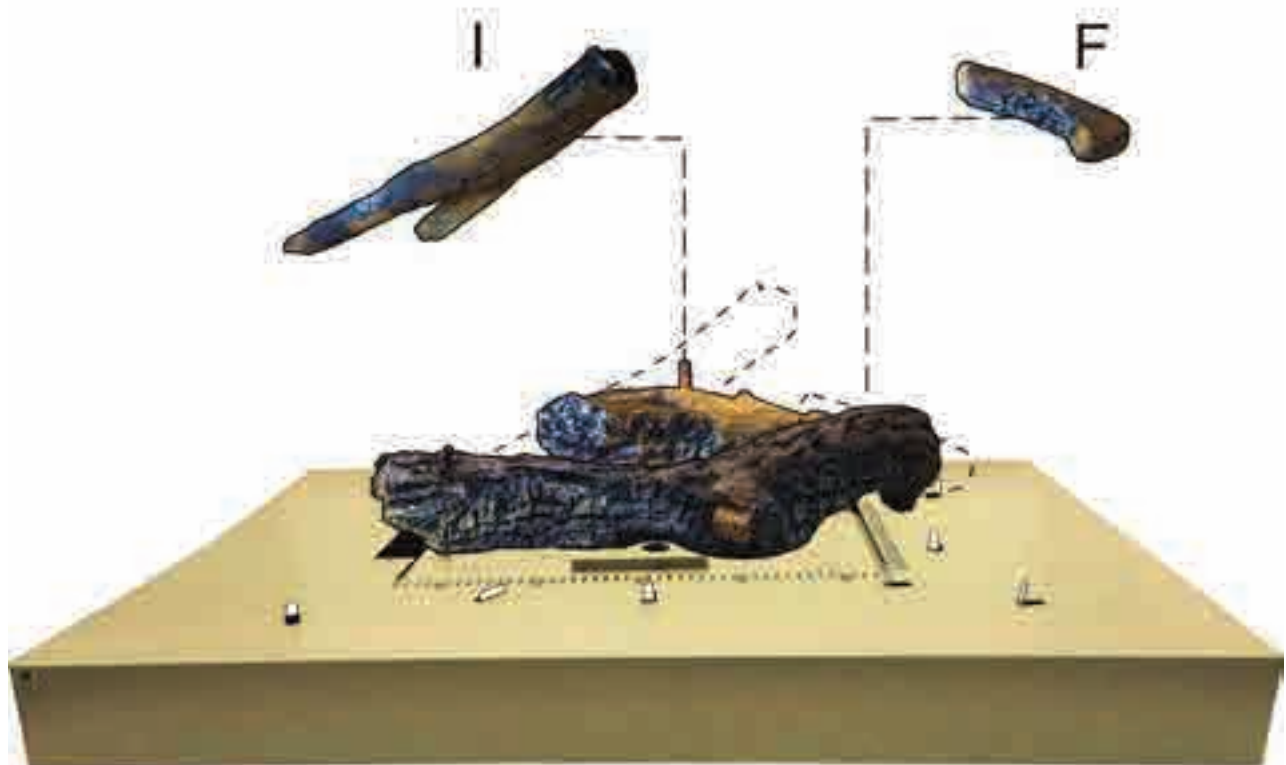
Front View

# LOG PLACEMENT - LSU24SPF

- Place Log I onto burner tab 1 and the left pin on Log E. Place Log F onto burner tab 5 and the right pin on Log E. Refer to the images on this page.



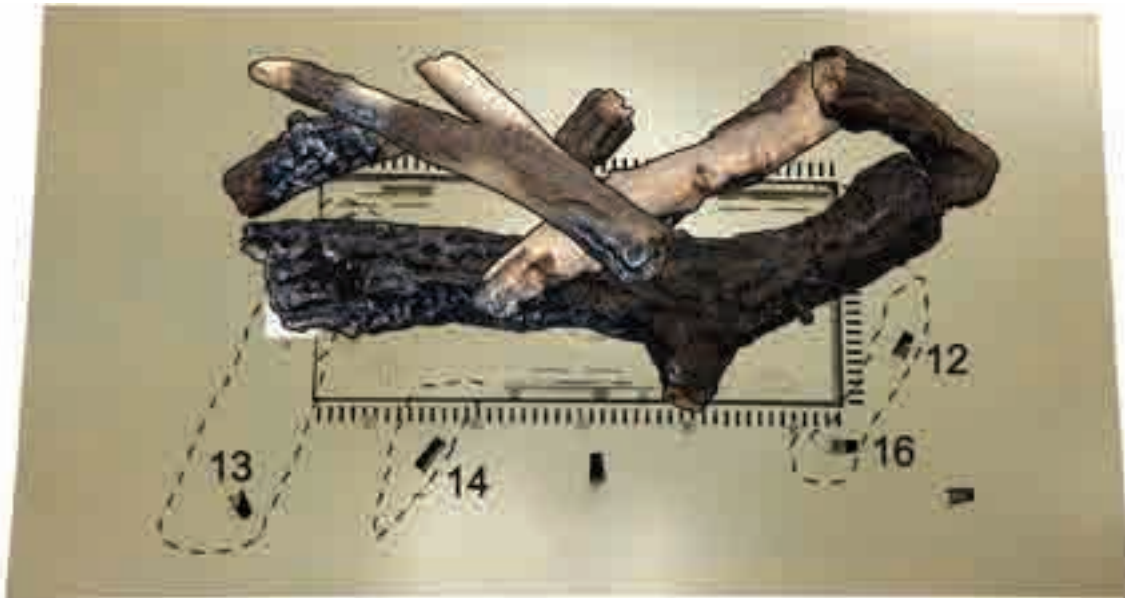
Top View



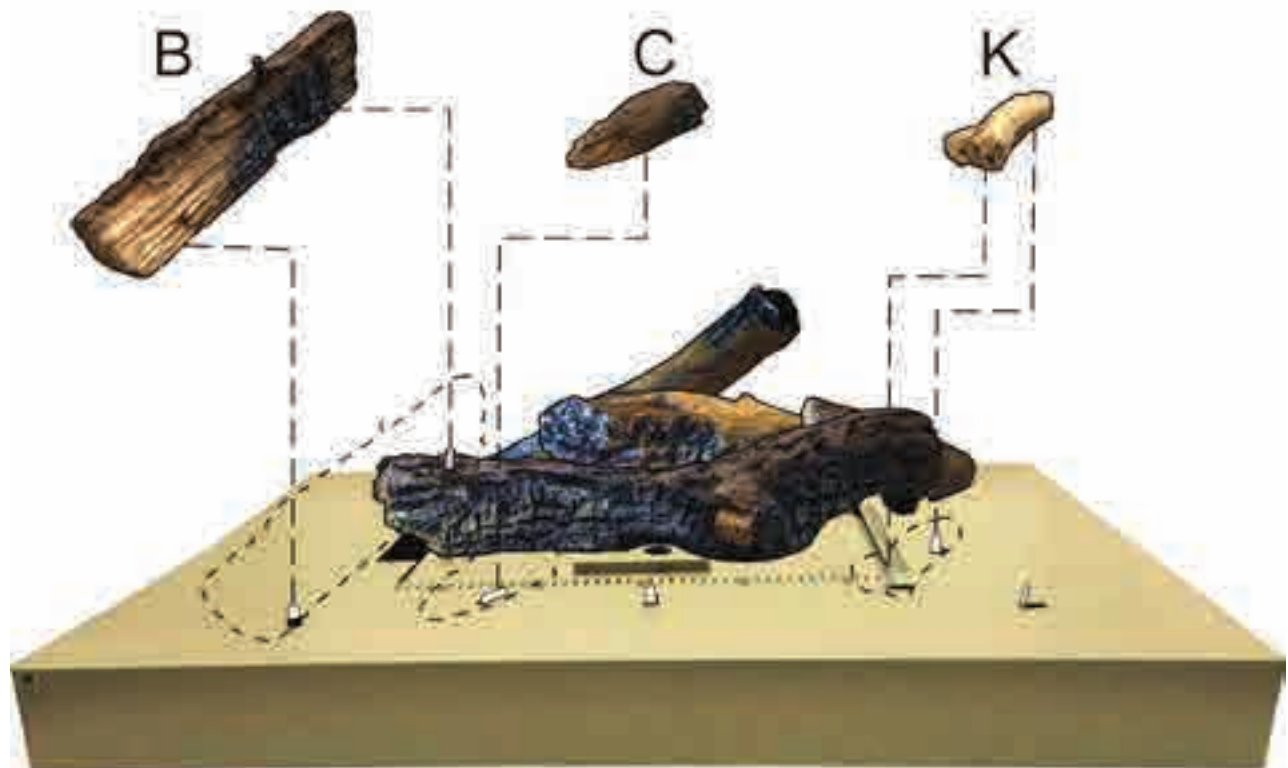
Front View

## LOG PLACEMENT - LSU24SPF

5. Place Log B onto burner tab 13 and left pin on Log A. Place Log C onto burner tab 14. Place Log K onto burner tabs 12 and 16. Refer to the images on this page.

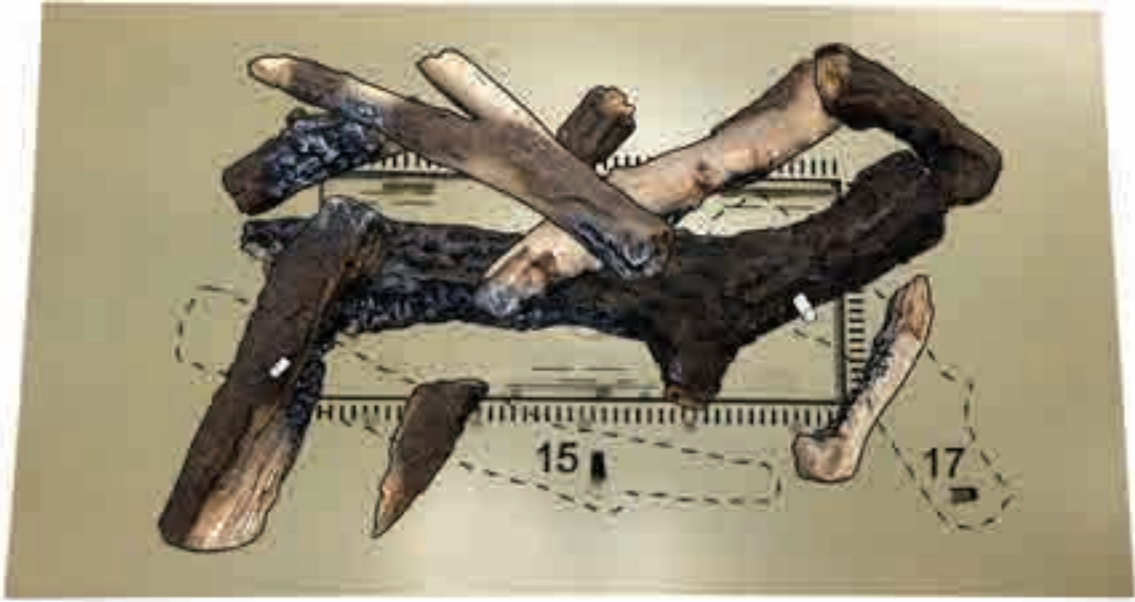


Top View

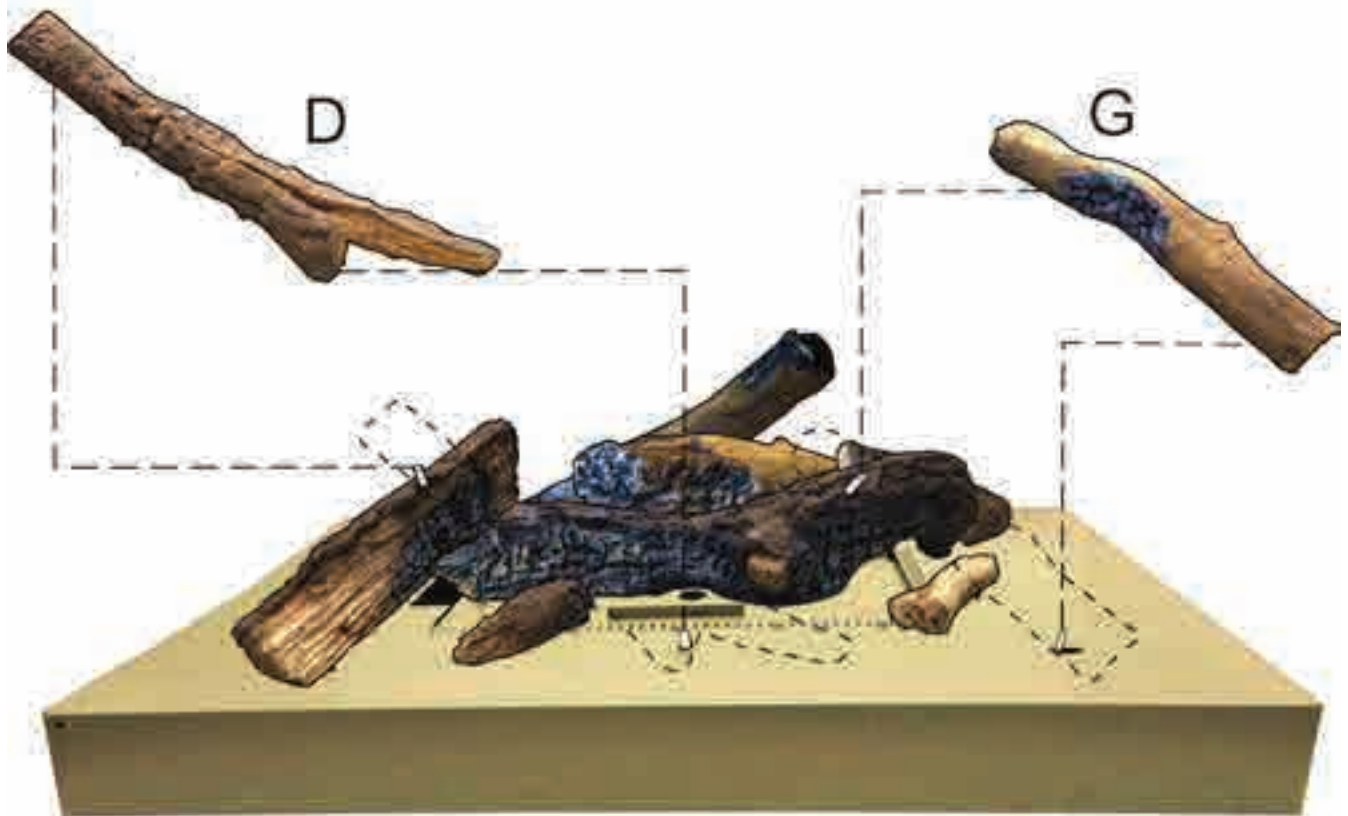


Front View

# LOG PLACEMENT - LSU24SPF



Top View



Front View

## LOG PLACEMENT - LSU24SPF

- Log placement is complete. Refer to the images on this page. A bag of "wood splinters" and vermiculite is included with your log set and may be arranged on the false floor to suit your preference. Do not place them on the burner.

























Top View













Front View

# LOG & STONE IDENTIFICATION - DG36MX

DESCRIPTION	PART NO.	FRONT VIEW	TOP VIEW
Stone A	36031		
Stone B	36030		
Stone C	36029		
Stone D	36032		
Stone E	36033		
Stone F	36037		
Stone G	36034		
Stone H	36035		
Stone I	36036		
Log J	36039		
Log K	36044		

**Attention:** When ordering parts, it is very important that **part number** and **description** coincide.

# LOG & STONE IDENTIFICATION - DG36MX

DESCRIPTION	PART NO.	FRONT VIEW	TOP VIEW
Log L	36040		
Log M	36042		
Log N	36038		
Log O	36043		
Log P	36041		

**Attention:** When ordering parts, it is very important that **part number** and **description** coincide.



# LOG & STONE PLACEMENT - DG36MX

Before you begin: Do not, handle these logs with your bare hands! Always wear gloves to prevent skin irritation. After handling logs, wash your hands gently with soap and water.

## All Logs

The positioning of the logs and rocks is critical to the safe and clean operation of this fireplace. Sooting and other problems may result if the logs are not properly and firmly positioned in the fireplace.

Refer to Figure 69 for the following warning.

### ⚠ WARNING

Failure to position the parts in accordance with this diagram or failure to use only parts specifically approved with this appliance may result in property damage or personal injury.

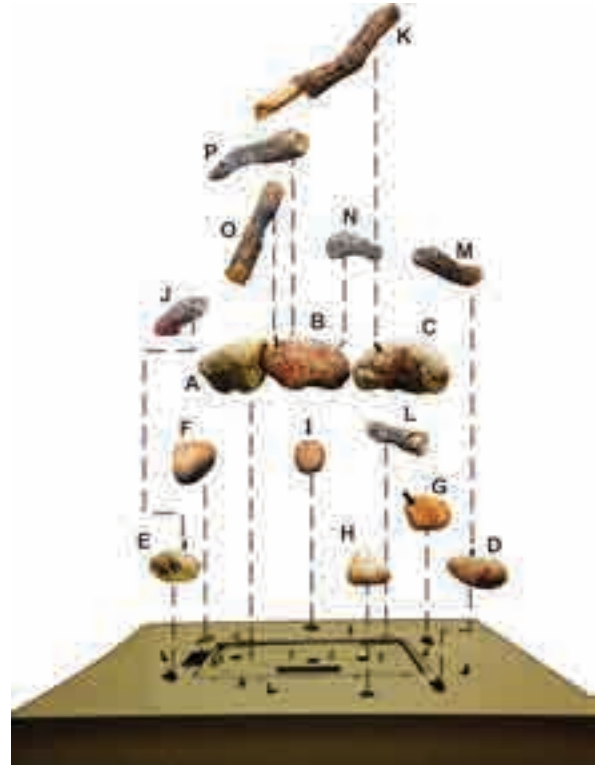
Attention: Do not use Figure 69 to order replacement logs. Refer to Page 47 - 48 Log and Rock Identification to order logs for your appropriate model number.

**NOTICE:** Once the installation is complete with the glowing embers and log set in place, operate the fireplace to verify flame appearance. If there are flames directly impinging a log, turn off fireplace, then remove the glowing ember material directly below where the flame impingement occurred. This should eliminate sooting on the log, and provide a more pleasing flame appearance.

Replacement of glowing embers must be purchased from an Empire Comfort Systems Dealer. Application of excess glowing embers may adversely affect performance of the fireplace.

### ⚠ WARNING

All previously applied loose material must be removed prior to reapplication.

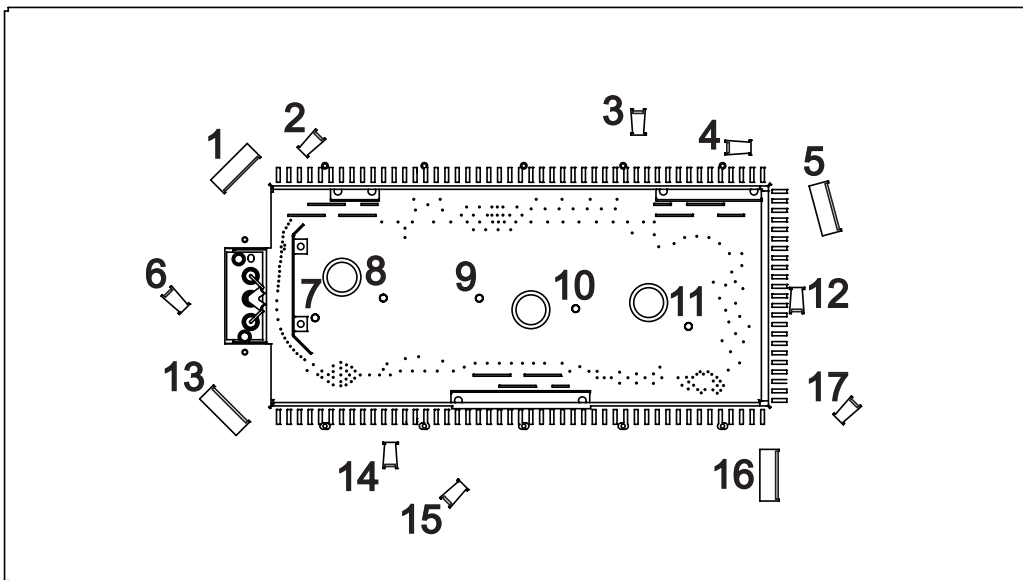


Log Placement Figure 69

FRONT VIEW - COMPLETED LOG SET INSTALLATION (WITHOUT EMBERS)



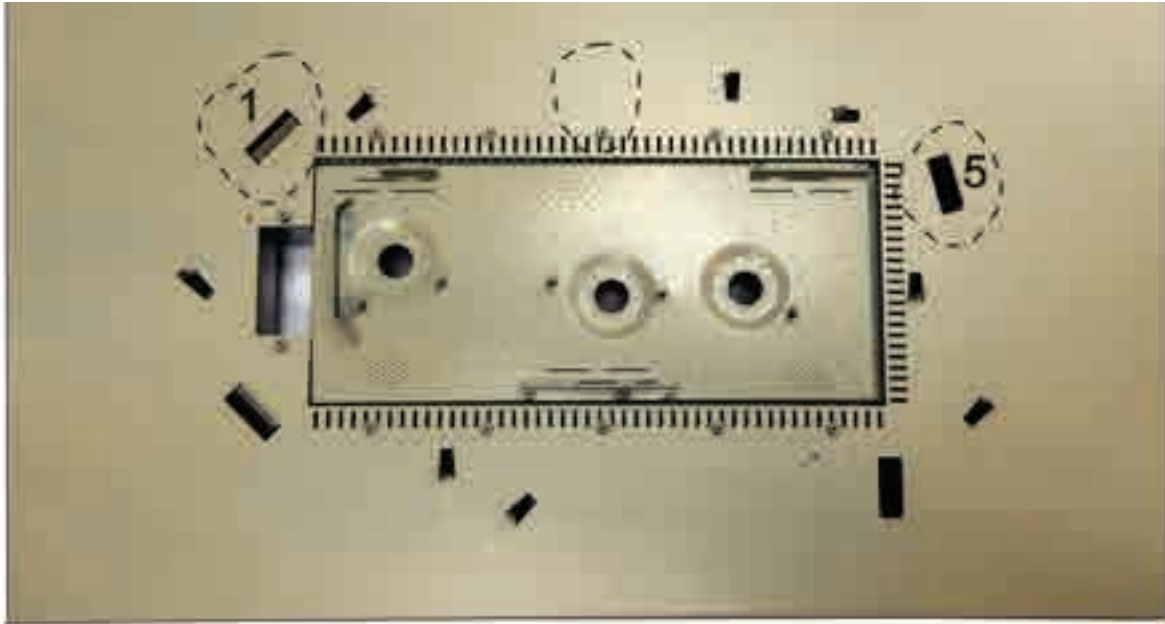
Figure 70



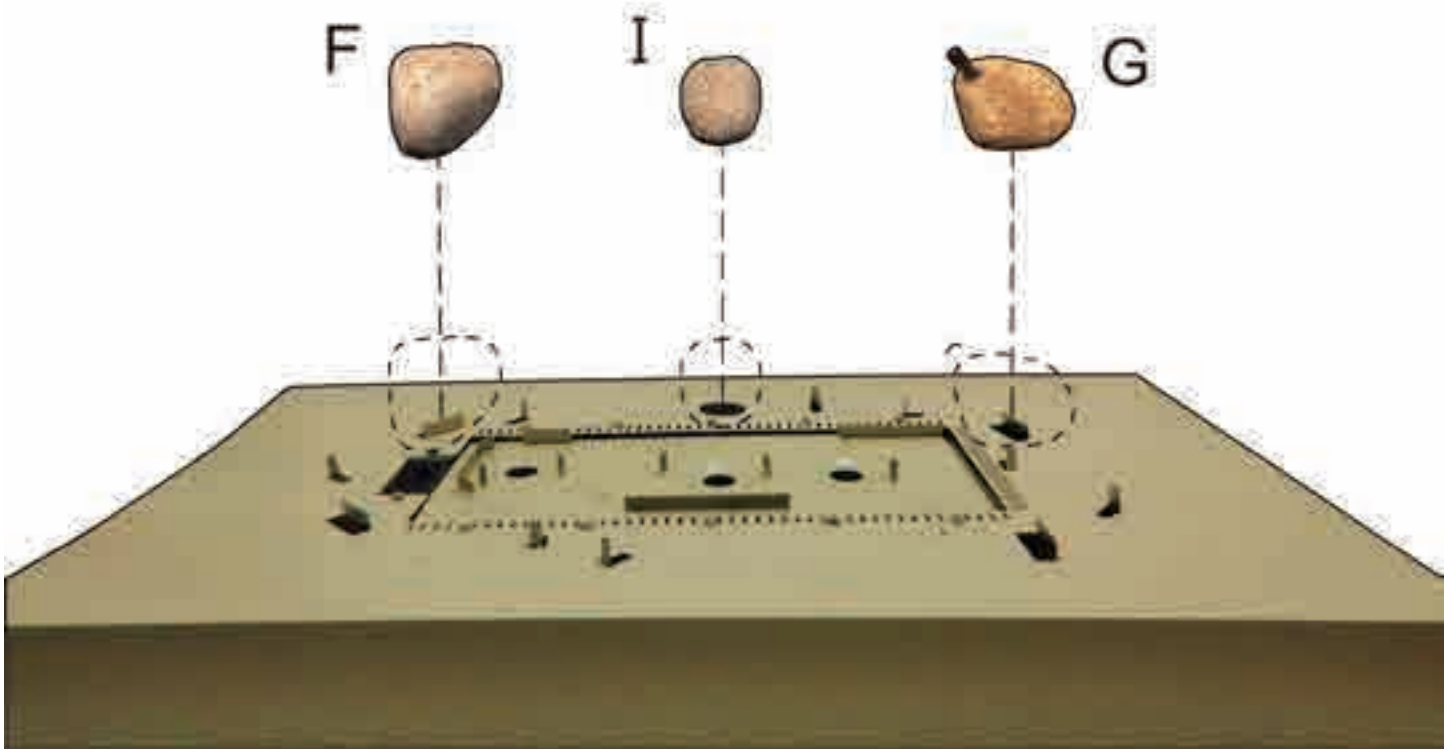
Burner Pin and Tab Identification - Figure 71

# LOG & STONE PLACEMENT - DG36MX

1. Place Stone F onto burner tab 1. Place Stone G onto burner tab 5. Place Stone I onto the false floor as shown below. Refer to the images on this page.



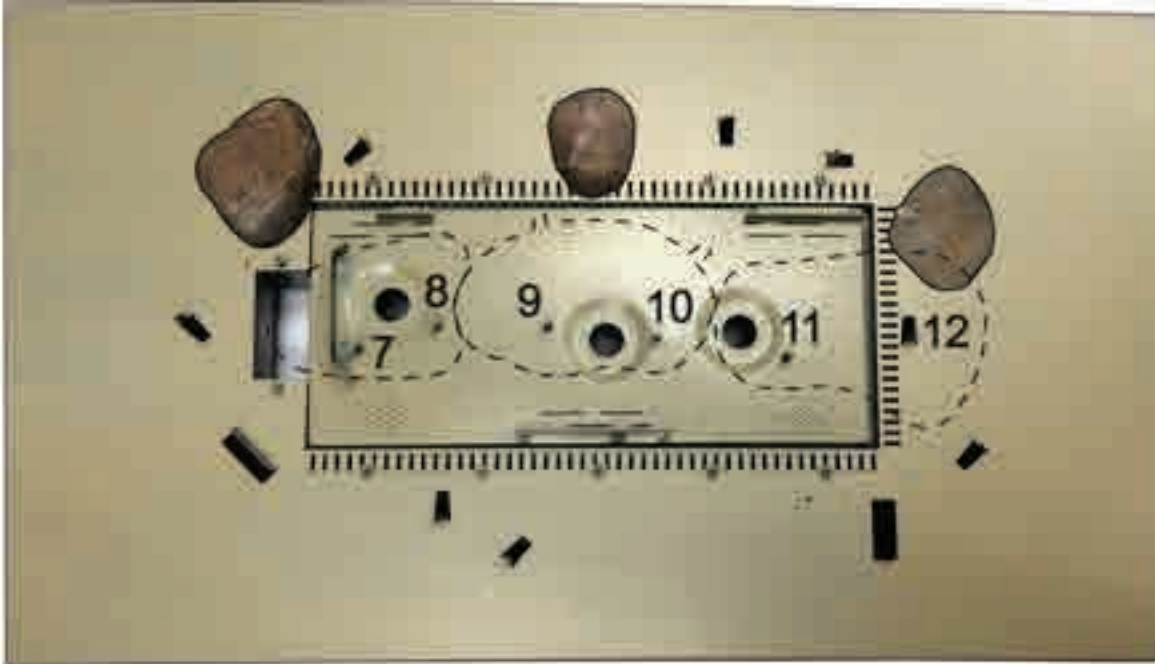
Top View



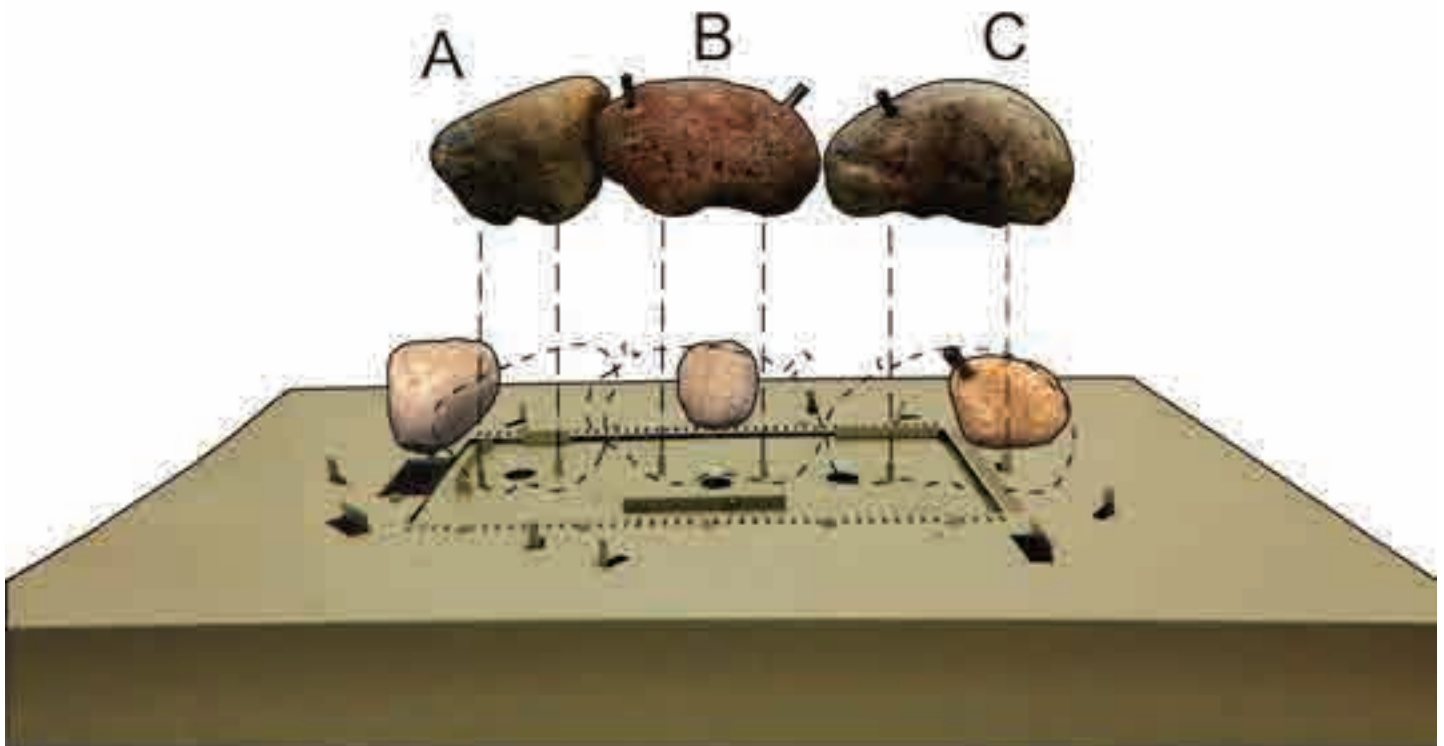
Front View

# LOG & STONE PLACEMENT - DG36MX

- Place Stone A onto burner pins 7 and 8. Place Stone B onto burner pins 9 and 10. Place stone C onto burner pin 11 and burner tab 12. Refer to the images on this page.



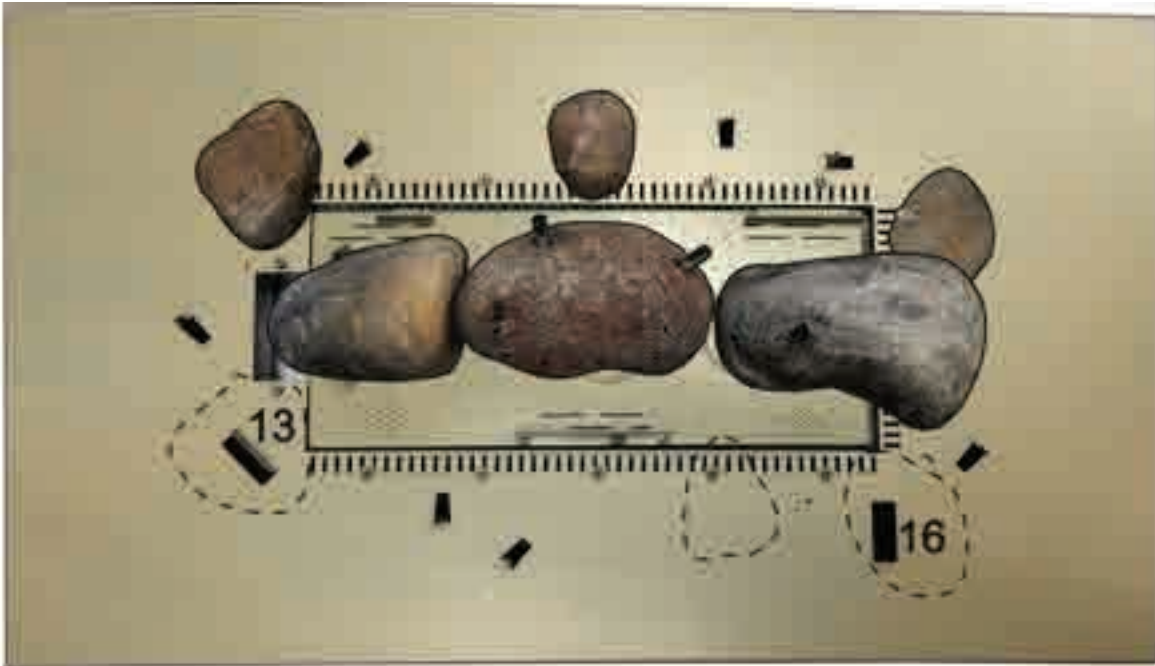
Top View



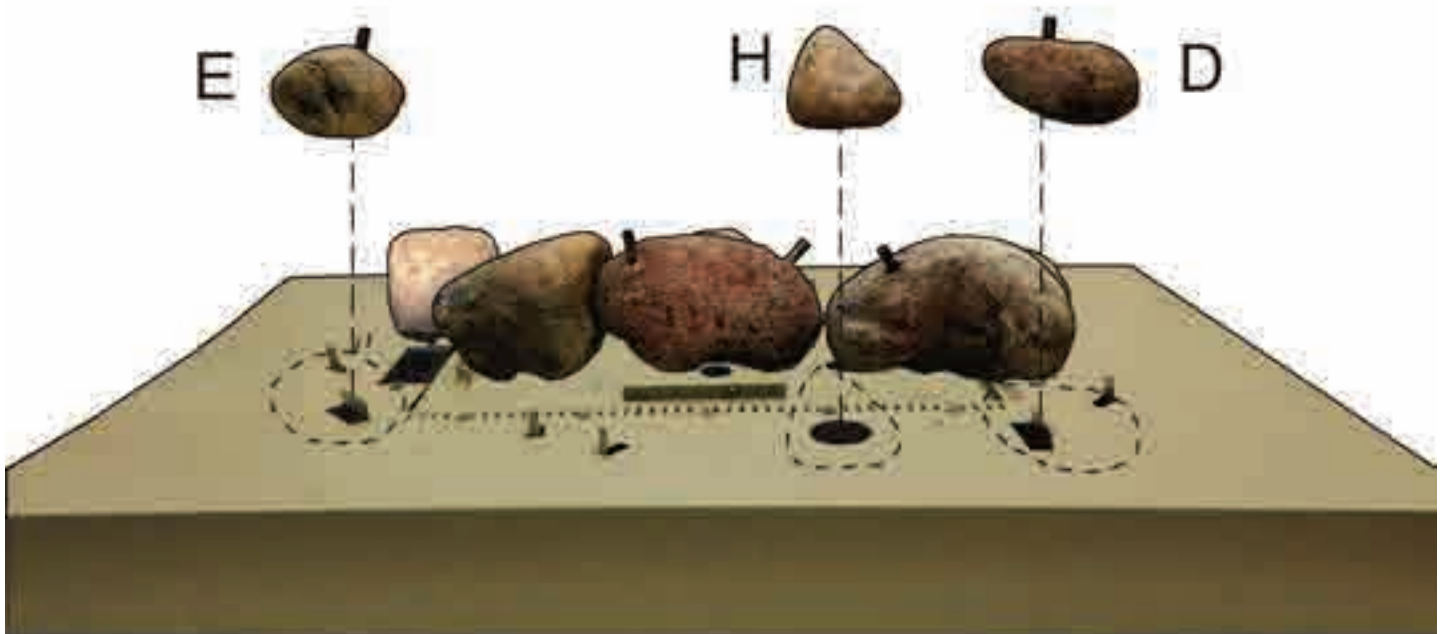
Front View

# LOG & STONE PLACEMENT - DG36MX

- Place Stone E onto burner tab 13. Place Stone D onto burner tab 16. Place Stone H onto the false floor as shown below. Refer to the images on this page.



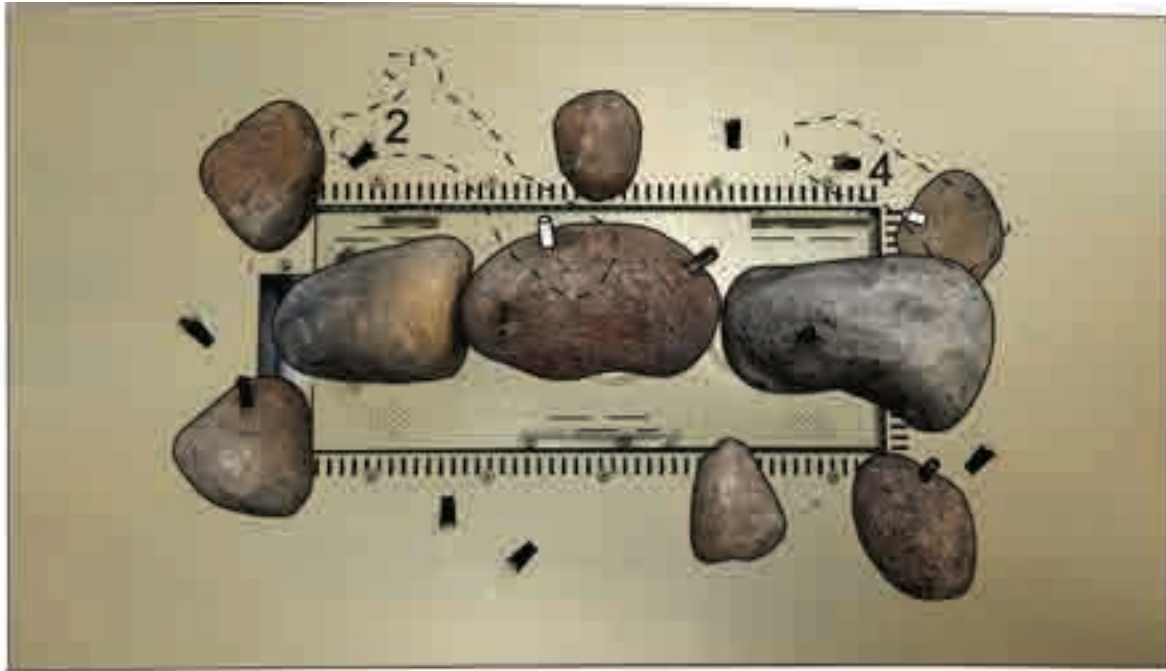
Top View



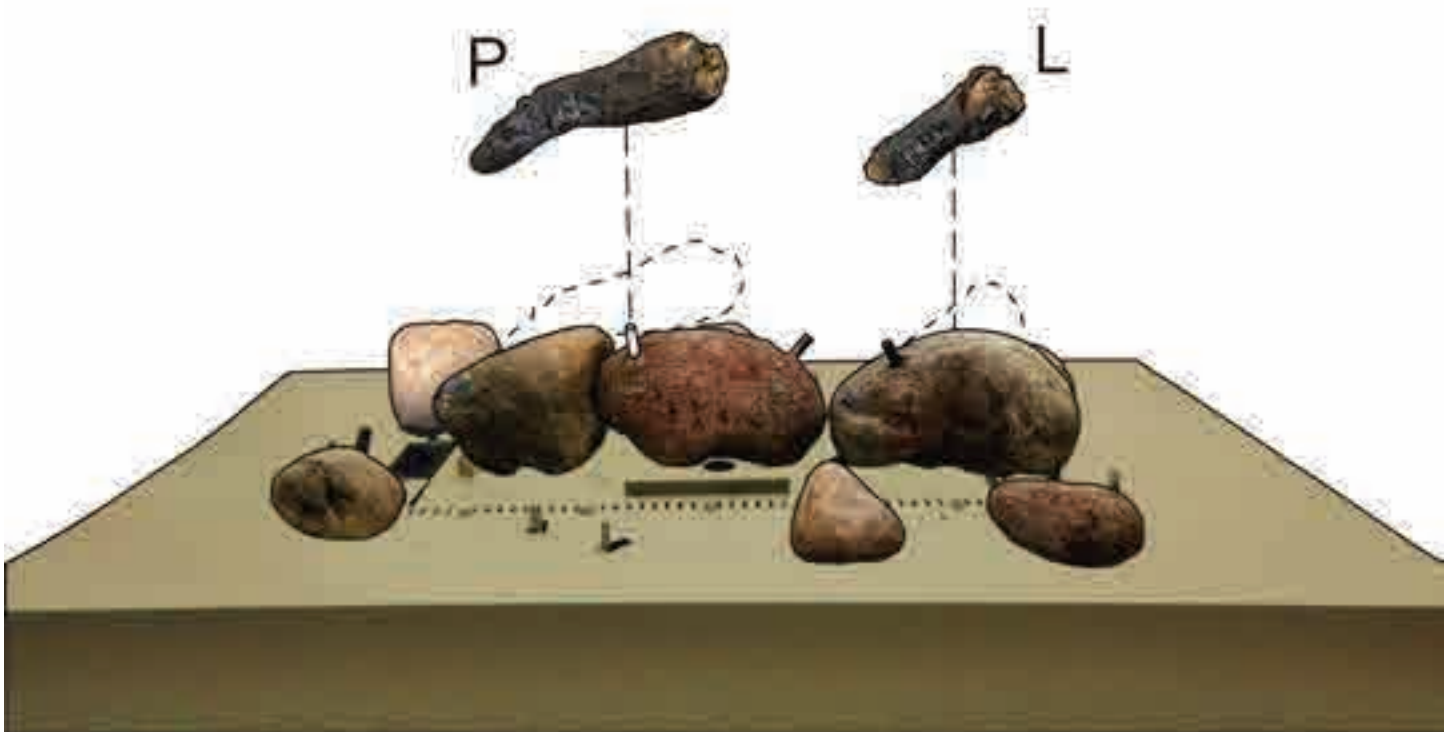
Front View

# LOG & STONE PLACEMENT - DG36MX

- Place Log P onto burner tab 2 and center pin on Stone B. Place Log L onto burner tab 4 and pin on Stone G. Refer to the images on this page.



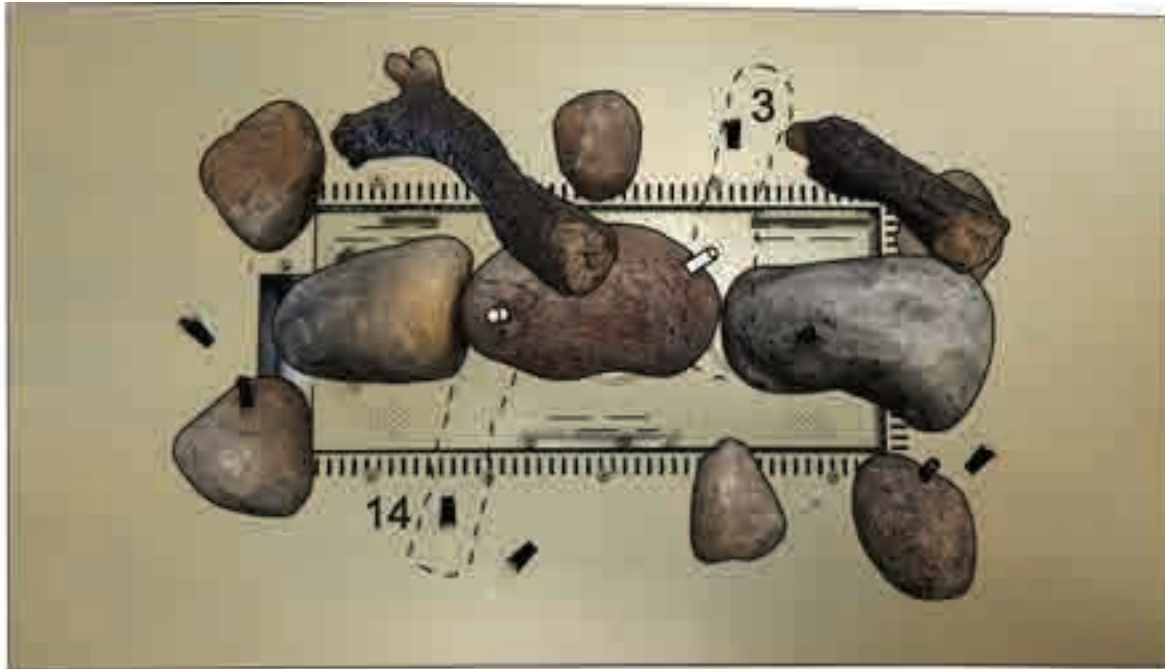
Top View



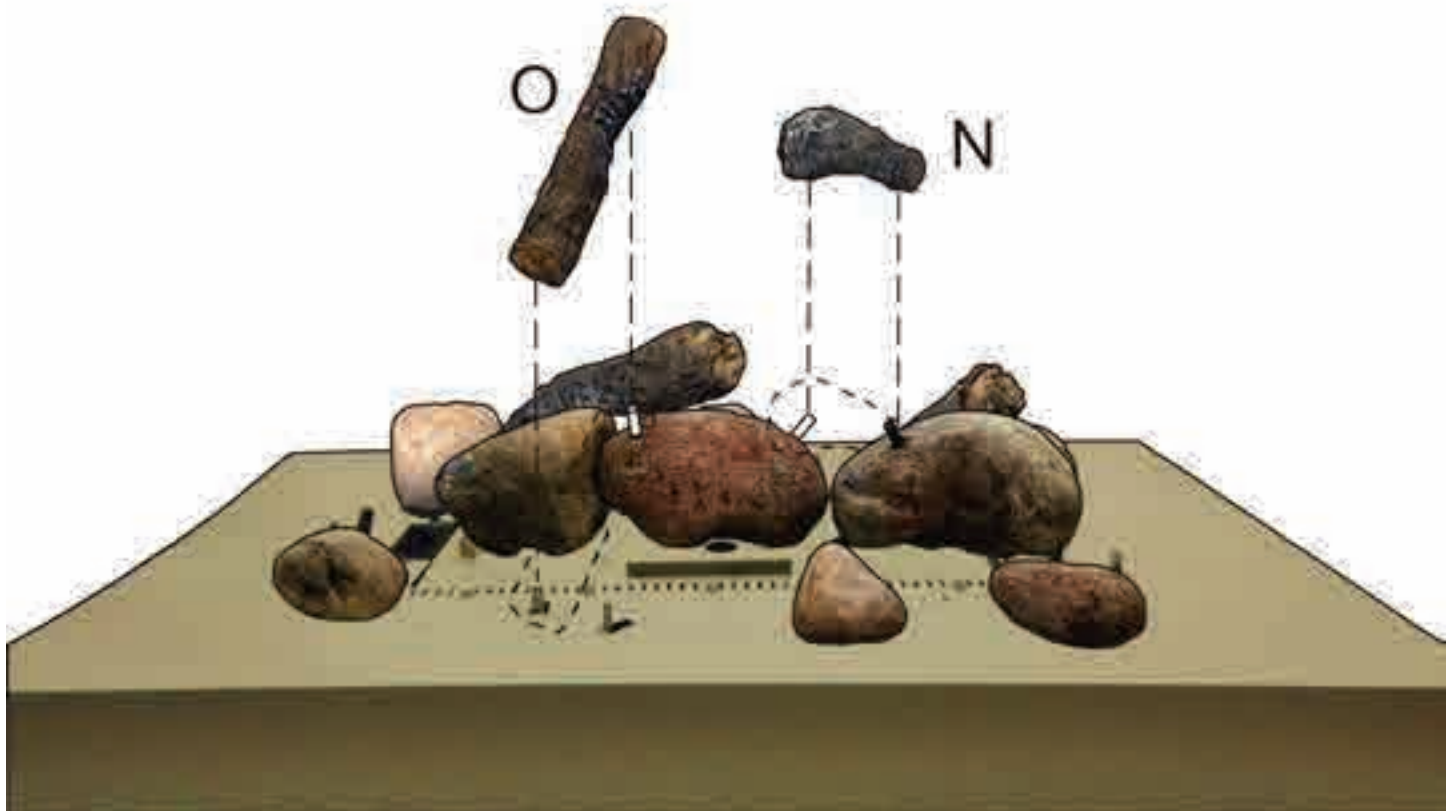
Front View

# LOG & STONE PLACEMENT - DG36MX

5. Place Log O onto burner tab 14 and left pin on Stone B. Place Log N onto burner tab 3 and right pin on Stone B. Refer to the images on this page.



Top View



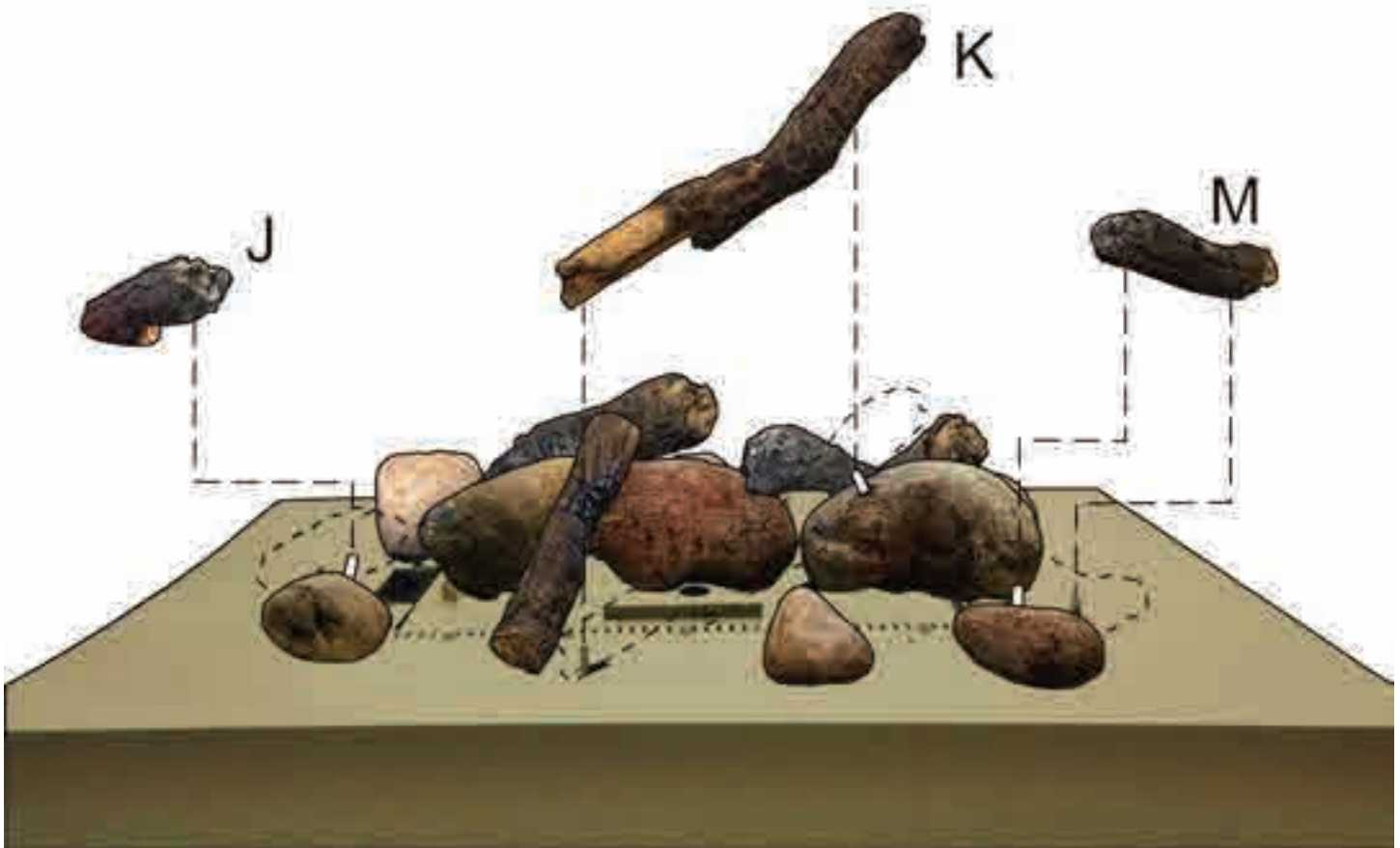
Front View

# LOG & STONE PLACEMENT - DG36MX

- Place Log J onto burner tab 6 and pin on Stone E. Place Log K onto burner tab 15 and pin and Stone C. Place Log M onto burner tab 17 and pin on Stone D. Refer to the images on this page.



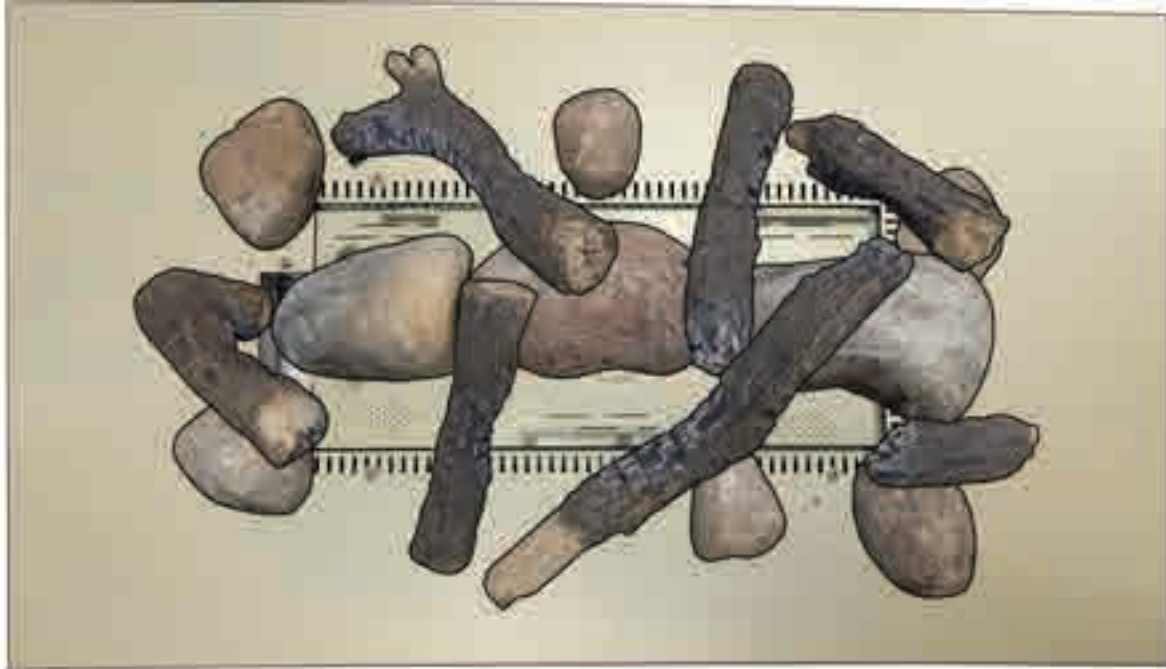
Top View



Front View

## LOG & STONE PLACEMENT - DG36MX

7. Log and Stone placement is complete. Refer to the images on this page. A bag of "wood splinters" and vermiculite is included with your mixed logs and stone set and may be arranged on the false floor to suit your preference. Do not place them on the burner.



Top View



Front View



# MILLIVOLT STANDING PILOT OPERATING INSTRUCTIONS

## Millivolt System

The standing pilot burns continuously even when the main burner is OFF.

When you ignite the pilot, the thermopile produces millivolts (electrical current) which energizes the magnet in the gas valve. Once lighted wait 30 seconds, release the gas control knob, and the pilot will stay ON. Allow the pilot flame to burn an additional one to two minutes before you turn the gas control knob from the PILOT position to the ON position. This allows the millivolts current to build-up to a sufficient level to operate the gas control properly.

1. Follow the SAFETY and LIGHTING INSTRUCTIONS for standing pilot controls found in this manual and on labels found in control compartment behind the door assembly.

### ⚠ CAUTION

During the initial purging and subsequent lightings, never allow the gas valve control knob to remain depressed in the "pilot" position without pushing the piezo ignitor button at least once every second.

2. During the operating season, leave the control valve knob in the "ON" position. This will allow the pilot flame to remain lit. Turn the burner flame on or off with the fireplace REMOTE/OFF/ON switch, wall switch or remote controls.

**NOTICE:** The gas control valve allows you to increase or decrease the height of the main burner flame. The control valve has a pressure regulator with a knob as shown in **Figure 72**. Rotate the knob clockwise to "HI" to increase the flame height and counterclockwise to "LO" to decrease the flame height.

3. When the heating season ends, turn the REMOTE/OFF/ON switch to "OFF" and the control valve to "OFF". The system, including the pilot light, will be shut down.

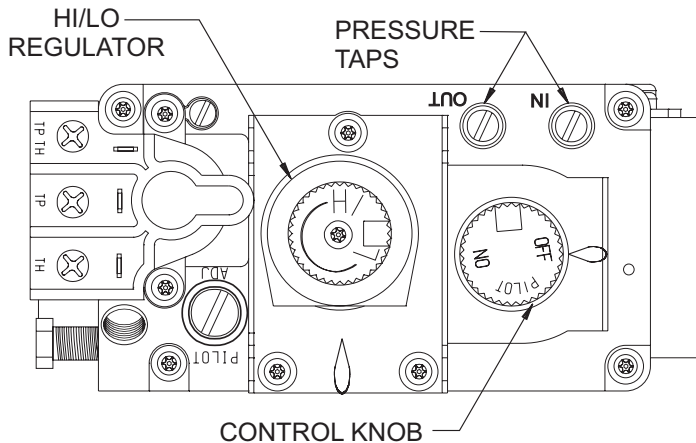


Figure 72

The OWNER should carefully read and follow these operating instructions.

## Initial Lighting

Remove the access panel to view the gas controls for the fireplace. Upon completing the gas line or turning the gas valve on after it has been in the "OFF" position, a small amount of air will be in the lines. When first lighting the fireplace, it will take a few minutes for the lines to purge this air. Once the purging is complete, the fireplace will light and operate satisfactorily.

Subsequent lightings will not require purging if the gas valve is not turned to OFF.

## Pilot Flame

The pilot flame should cover the thermopile and thermocouple.

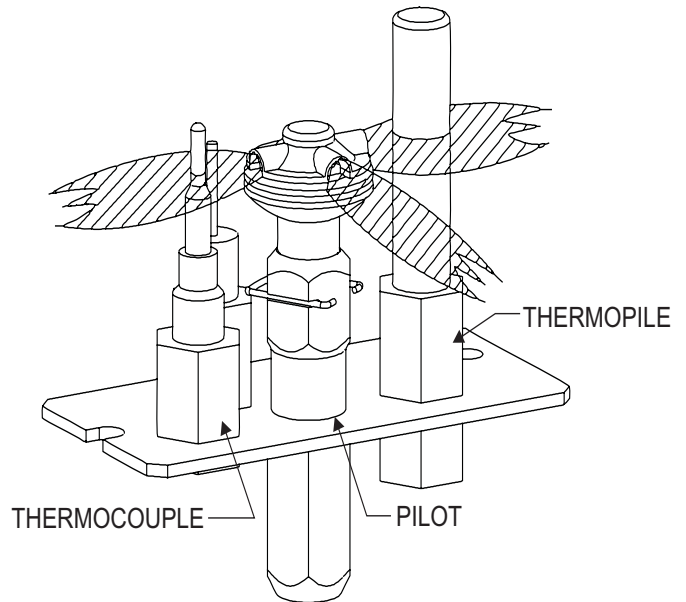


Figure 73

# MILLIVOLT STANDING PILOT OPERATING INSTRUCTIONS

## STANDING PILOT OPERATING INSTRUCTIONS

### REMOTE/OFF/ON Switch

The fireplace is equipped with a REMOTE/OFF/ON switch. A wire harness is attached to the REMOTE/OFF/ON switch. The red, black and green (wires) female push-ons attach to the REMOTE/OFF/ON switch. At the opposite end of the wire harness, the black and green (wires) female push-ons attach to the gas valve. An additional red and green wire are secured together with a wire nut. Remove the wire nut and separate the wires to connect a switch or remote.

### Operation of REMOTE/OFF/ON Switch with no Accessories

To ignite main burner, turn the control knob on the gas valve from the PILOT position to the ON position. Turn the REMOTE/OFF/ON switch from the OFF position to the ON position. The fireplace will also turn on in the REMOTE position if the additional red and green wires are connected together with a wire nut.

### Wall Switch, FWS-1

Connect the green and red, stripped and bare, wires on the REMOTE/OFF/ON switch wire harness to the wall switch. Turn the REMOTE/OFF/ON switch to the REMOTE position. Pivot the rocker switch on the FWS-1 to the ON position.

### Wall Thermostats (optional)

TRW - Wireless for Millivolt models

TMV - Reed switch for Millivolt models

### Battery Operated Remote Controls, FRBC, FBRTC, and TRW

Connect the green and red, stripped and bare, wires on the REMOTE/OFF/ON switch wire harness to the remote receiver that is a component in the remote kit. Turn the REMOTE/OFF/ON switch to the REMOTE position. Follow instructions included with the remote to complete installation.

**NOTICE:** If batteries fail in the remote, and immediate heat is desired, turn the REMOTE/OFF/ON switch from the REMOTE position to the ON position.

### Installation of Remote Receiver

Place remote receiver on the floor of fireplace behind the louver as far forward as possible.

**Attention:** The Velcro loop and hook are not necessary in this installation but can be used to secure remote receiver.

Refer to remote control installation and operating instructions for more details on remote control.

### Millivolt Control

The valve regulator controls the burner pressure which should be checked at the pressure test point. Turn captured screw counter clockwise 2 or 3 turns and then place tubing to pressure gauge over test point (Use test point "A" closest to control knob). After taking pressure reading, be sure and turn captured screw clockwise firmly to re-seal. Do not over torque. Check for gas leaks. See Figure 72 for pressure tap locations.

Millivolt thermopile is self generating. Gas valve does not require 24 volts or 110 volts.

### Check System Operation

Millivolt system and all individual components may be checked with a millivolt meter 0-1000 MV range. The millivolt readings should be:

- Across the thermopile terminals, 400-450 millivolts with thermostat OFF.
- Across the thermopile terminals, 150-250 millivolts with thermostat ON.
- Across the thermostat wires at the valve, less than 30 millivolts with thermostat ON.
- Across the thermostat wires at the thermostat, less than 5 millivolts with thermostat ON. (Strong winds, dirty pilot and low pressure will reduce readings.)

Use wire of a gauge proper for the length of the wire:

RECOMMENDED WIRE GAUGES	
Maximum Length	Wire Gauge
1ft to 10ft	18
10ft to 25ft	16
25ft to 35ft	14

# MILLIVOLT STANDING PILOT WIRING DIAGRAM

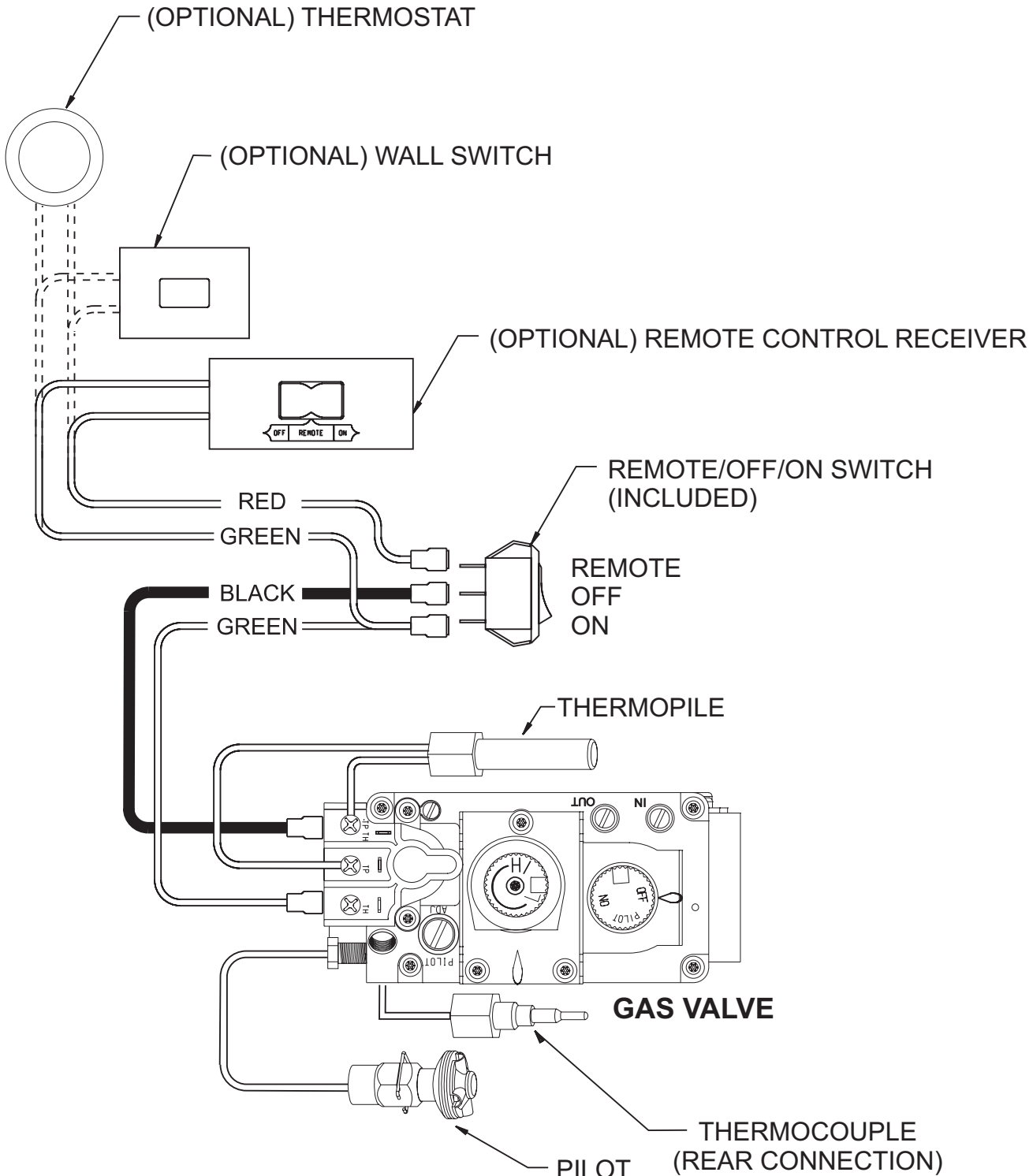


Figure 74

## ⚠ WARNING

**Electrical Grounding Instructions**  
 This fireplace is equipped with a three-prong (grounding) plug for your protection against shock hazard and should be plugged directly into a properly grounded three-prong receptacle. Do not cut or remove the grounding prong from this plug.

## ⚠ CAUTION

Label all wires prior to disconnection when servicing controls. Wiring errors can cause improper and dangerous operation.

Verify proper operation after servicing.

# MILLIVOLT STANDING PILOT LIGHTING INSTRUCTIONS

## FOR YOUR SAFETY READ BEFORE LIGHTING

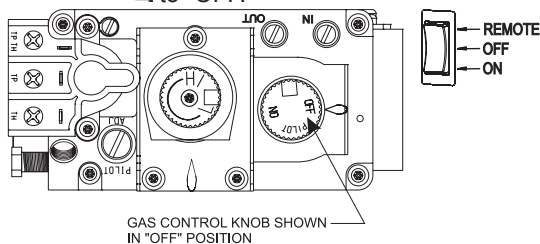
### ⚠ WARNING

If you do not follow these instructions exactly, a fire or explosion may result causing property damage, personal injury or loss of life

- A. This appliance has a pilot which must be lighted by hand. When lighting the pilot, follow these instructions exactly.
- B. Before lighting smell all around the appliance area for gas. Be sure to smell next to the floor because some gas is heavier than air and will settle on the floor.  
What To Do If You Smell Gas
  - Do not try to light any appliance.
  - Do not touch any electrical switch;
  - Do not use any phone in your building.
  - Immediately call your gas supplier from a neighbor's phone. Follow the gas supplier's instructions.
  - If you cannot reach your gas supplier, call the fire department.
- C. Use only your hand to push in or turn the gas control knob. Never use tools. If the knob will not push in or turn by hand, don't try to repair it; call a qualified service technician. Force or attempted repair may result in a fire or explosion.
- D. Do not use this appliance if any part has been under water. Immediately call a qualified service technician to inspect the appliance and to replace any part of the control system and any gas control which has been under water.

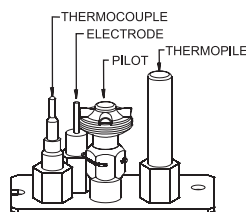
## LIGHTING INSTRUCTIONS

1. Stop! Read the safety information above.
2. Set REMOTE/OFF/ON switch to OFF.
3. Turn off all electric power to the appliance (if applicable).
4. Lift off bottom access panel
5. Push in gas control knob slightly and turn clockwise to "OFF."



**NOTICE:** Knob cannot be turned from "PILOT" to "OFF" unless knob is pushed in slightly. Do not force.

6. Wait ten minutes to clear out any gas. Then smell for gas, including near the floor. If you then smell gas, STOP! Follow "B" in the safety information above. If you do not smell gas, go to the next step.
7. Find pilot - Follow metal tube from gas control. The pilot is behind the burner on the right side.



8. Turn gas control knob counterclockwise to "PILOT."
9. Push in control knob all the way and hold in. Repeatedly push the piezo ignitor button until the pilot is lit. Continue to hold the control knob in the for about one minute after the pilot is lit. Release knob, and it will pop back up. Pilot should remain lit. If it goes out, repeat steps 5 through 9.
  - If the control knob does not pop up when released, STOP and IMMEDIATELY call a qualified service technician or gas supplier.
  - If the pilot will not stay lit after several tries, turn the gas control knob to "OFF" and call your service technician or gas supplier.
10. Turn gas control knob counterclockwise to "ON."
11. Replace bottom access panel
12. Turn on all electric power to the appliance (if applicable).
13. Set REMOTE/OFF/ON switch to desired setting.

## TO TURN OFF GAS TO FIREPLACE

1. Set REMOTE/OFF/ON switch to OFF.
2. Turn off all electric power to the appliance if service is to be performed (if applicable).
3. Lift off bottom access panel
4. Push in gas control knob slightly and turn clockwise to "OFF." Do not force.
5. Replace bottom access panel.

# MILLIVOLT STANDING PILOT TROUBLESHOOTING

With proper installation and maintenance, your new Direct Vent Gas Fireplace will provide years of trouble-free service. If you do experience a problem, refer to the Trouble Shooting Guide below. This guide will assist a qualified service person in the diagnosis of problems and the corrective action to be taken.

## 1. Spark ignitor will not light pilot after repeated triggering of piezo ignitor button.

- a. Defective ignitor (no spark at electrode)
  - Clean spark electrode
  - Check for spark at electrode and pilot; if no spark and electrode wire is properly connected, replace ignitor.
- b. No gas or low gas pressure.
  - Check remote shut off valves from fireplace. Usually there is a valve near the main. There can be more than one valve between the fireplace and main.
  - Low pressure can be caused by a variety of situations such as a bent line, too narrow diameter of pipe, or low line pressure. Consult with plumber or gas supplier.
- c. No LP in tank.
  - Check LP (propane) tank. Refill tank.

## 2. Pilot will not stay lit after carefully following lighting instructions.

- a. Defective thermocouple.
  - Check that pilot flame impinges on thermocouple. Clean and/or adjust pilot for maximum flame impingement.
  - Ensure the thermocouple connection at the gas valve is fully inserted and tight (hand tight plus 1/4 turn). Faulty thermocouple if reading is below specified minimum of 15 millivolts.
  - Disconnect the thermocouple from the valve, place one millivolt meter lead wire on the end of the thermocouple and the other millivolt meter lead wire on the thermocouple copper wire. Start the pilot and hold the valve knob in. If the millivolt reading is less than 15 millivolt, replace the thermocouple.
- b. Defective valve.
  - If thermocouple is producing more than 15 millivolts, replace faulty valve.

## 3. Pilot burning, no gas to burner, valve knob "ON", REMOTE/OFF/ON switch "ON."

- a. REMOTE/OFF/ON switch, wall switch, remote control or wires defective.
  - Check REMOTE/OFF/ON switch and wires for proper connections. Place jumper wires across terminal at switch. If burner comes on, replace defective switch. If OK, place jumper wires across switch wires at gas valve-if burner comes on, wires are faulty or connections are bad.
- b. Thermopile may not be generating sufficient millivolts.
  - If the pilot flame is not close enough physically to the thermopile, adjust the pilot flame.
  - Clean pilot orifice
  - Be sure the wire connections from the thermopile at the gas valve terminals are tight and the thermopile is fully inserted into the pilot bracket.
  - Clean thermopile
  - Check the thermopile with a millivolt meter. Take the reading at TH-TP & TP terminals of the gas valve. The meter should read 350 millivolts minimum, while holding the valve knob depressed in the PILOT position, with the pilot lit, and the REMOTE/OFF/ON switch in the OFF position. Replace the faulty thermopile if the reading is below the specified minimum.

— With the pilot in the ON position, disconnect the thermopile leads from the valve. Take a reading at the thermopile leads. The reading should be 350 millivolts minimum. Replace the thermopile if the reading is below the minimum.

- c. Defective valve.
  - Turn valve knob to ON. Place REMOTE/OFF/ON switch to ON. Check with millivolt meter at thermopile terminals. Millivolt meter should read greater than 200 millivolts. If the reading is okay and the main burner does not ignite, replace the gas valve.
- d. Plugged main burner orifice.
  - Check main burner orifice for blockage and remove.

## 4. Frequent pilot outage problem.

- a. Pilot flame may be too high or too low, or blowing (high), causing pilot safety to drop out.
  - Clean and adjust flame for maximum flame impingement on the thermocouple. Follow lighting instructions carefully.

## 5. The pilot and main burner extinguish while in operation.

- a. No LP (Propane) in tank.
  - Check LP (Propane) tank. Refill fuel tank.
- b. Inner vent pipe leaking exhaust gases back into system
  - Check for leaks.
- c. Glass too loose, gasket leaks in corners after usage.
  - Be certain glass assembly is installed correctly.
- d. Horizontal vent improperly pitched.
  - The horizontal vent cap should slope down only enough to prevent any water from entering the fireplace. The maximum downwards slope is 1/4 inch.
- e. Bad thermopile or thermocouple.
  - Replace if necessary.
- f. Improper vent cap installation.
  - Check for proper installation and freedom from debris or blockage.

## 6. Glass soots.

- a. Flame impingement on logs.
  - Check doors are sealed
  - Check and adjust log position. Contact your Empire Comfort Systems Dealer
- b. Debris around throat of main burner.
  - Inspect the opening at the base of the main burner. It is imperative that NO material be placed in this opening.

## 7. Flame burns blue and lifts off main burner.

- a. Insufficient oxygen being supplied.
  - Check to make sure vent cap is installed properly and free of debris. Make sure that vent system joints are tight and have no leaks.
  - Check to make sure that no material has been placed at the main burner base.

# INTERMITTENT PILOT ELECTRONIC SYSTEM OPERATING INSTRUCTIONS

## 5.25 VDC ELECTRONIC CONTROL VALVE

The electronic control valve system includes the ability to switch the pilot from a standing pilot mode to an intermittent pilot mode.

- **IPI Mode** - In the Intermittent Pilot mode, when the fireplace is turned ON, it will cause spark to the pilot, light the pilot, then allow the burner to light. When the fireplace is turned to OFF, both the burner and pilot will be OFF.
- **CPI Mode** - In the Continuous Pilot mode, the pilot remains ON continuously even when the burner is turned OFF.

**NOTICE:** A small toggle switch is located on the front of the module tray that is used to switch from IPI (left) to the CPI (right). See Figure 75.

When the fireplace is turned to ON, the electrical current will energize a spark to the pilot igniter. Once the pilot sensor heats up (after a few seconds), the valve will be energized, allowing gas to flow to the burner.

1. Follow the SAFETY and LIGHTING INSTRUCTIONS for Intermittent Pilot controls found in this manual, and on labels found in the control compartment located in the lower cavity of the fireplace.
2. During the heating season (or in power outage periods), it is recommended that the pilot remain in the CPI (standing pilot mode) to reduce cold start issues, and/or conserve battery backup power during a power outage.
3. The gas valve has inlet and outlet pressure taps as shown in Figure 75. Refer to page 16 for gas pressure requirements.

**NOTICE:** The gas control has a manual HI/LO flame adjustment knob (regulator) that allows you to increase or decrease the height of the burner flame. See Figure 75. Rotate the HI/LO knob counterclockwise to "HI" to increase the flame height, and clockwise to "LO" to decrease the flame height.

### OPTIONAL REMOTE CONTROLS

Optional remote controls are available for use with this fireplace. It is recommended that the remote receiver be placed either in a wall outlet box with extended wiring, on the fireplace hearth, or in the control compartment area as far forward in the insert as possible.

The placement options for the remote receiver are given to allow flexibility, however battery life will be extended when the receiver is placed in cooler areas.

To connect the remote receiver to the fireplace, first disconnect the ON/OFF switch wires from the white and green wire connectors and connect the wires from the remote receiver to the green and white wire connectors. See Page 63.

Follow the instructions included with the remote control for programming and other operational information.

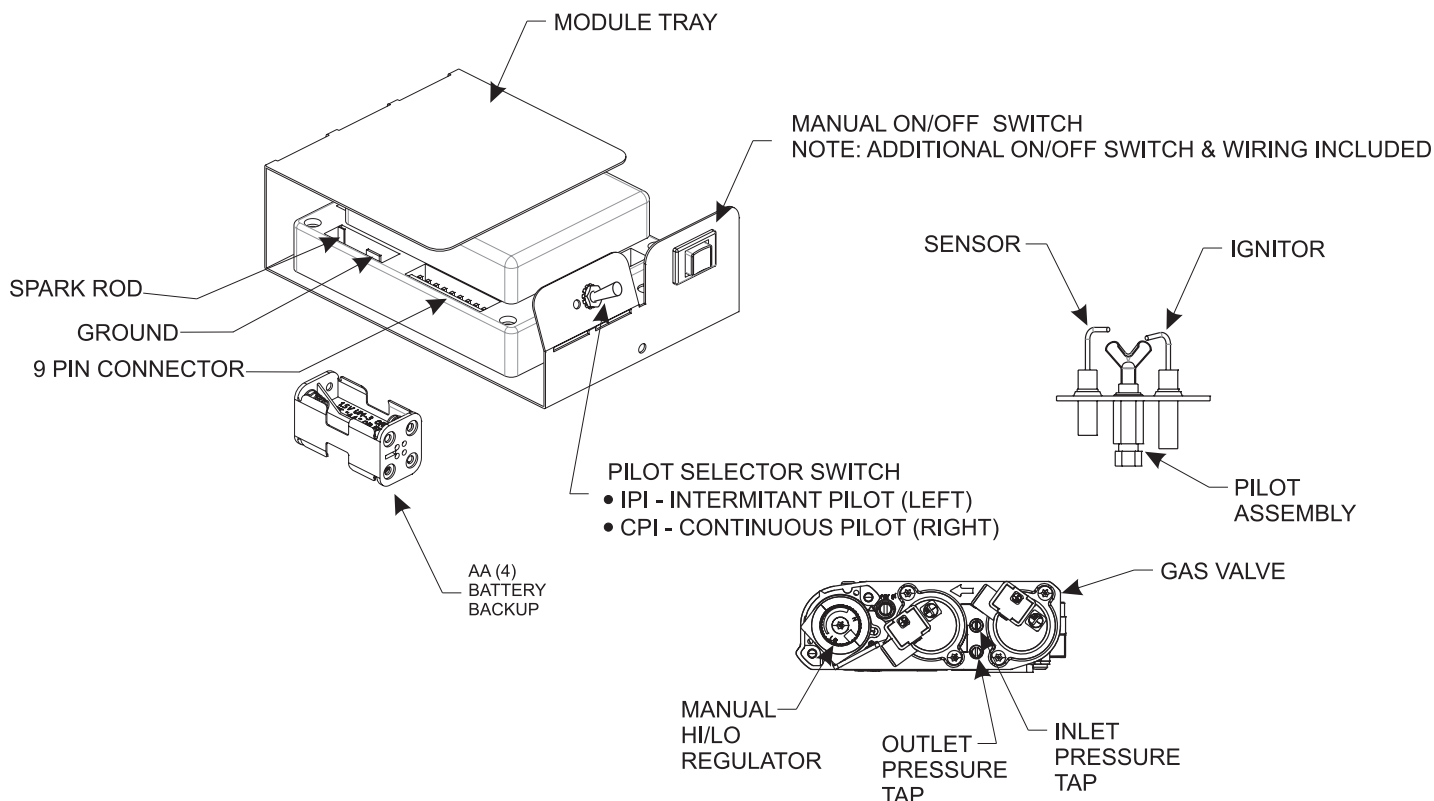
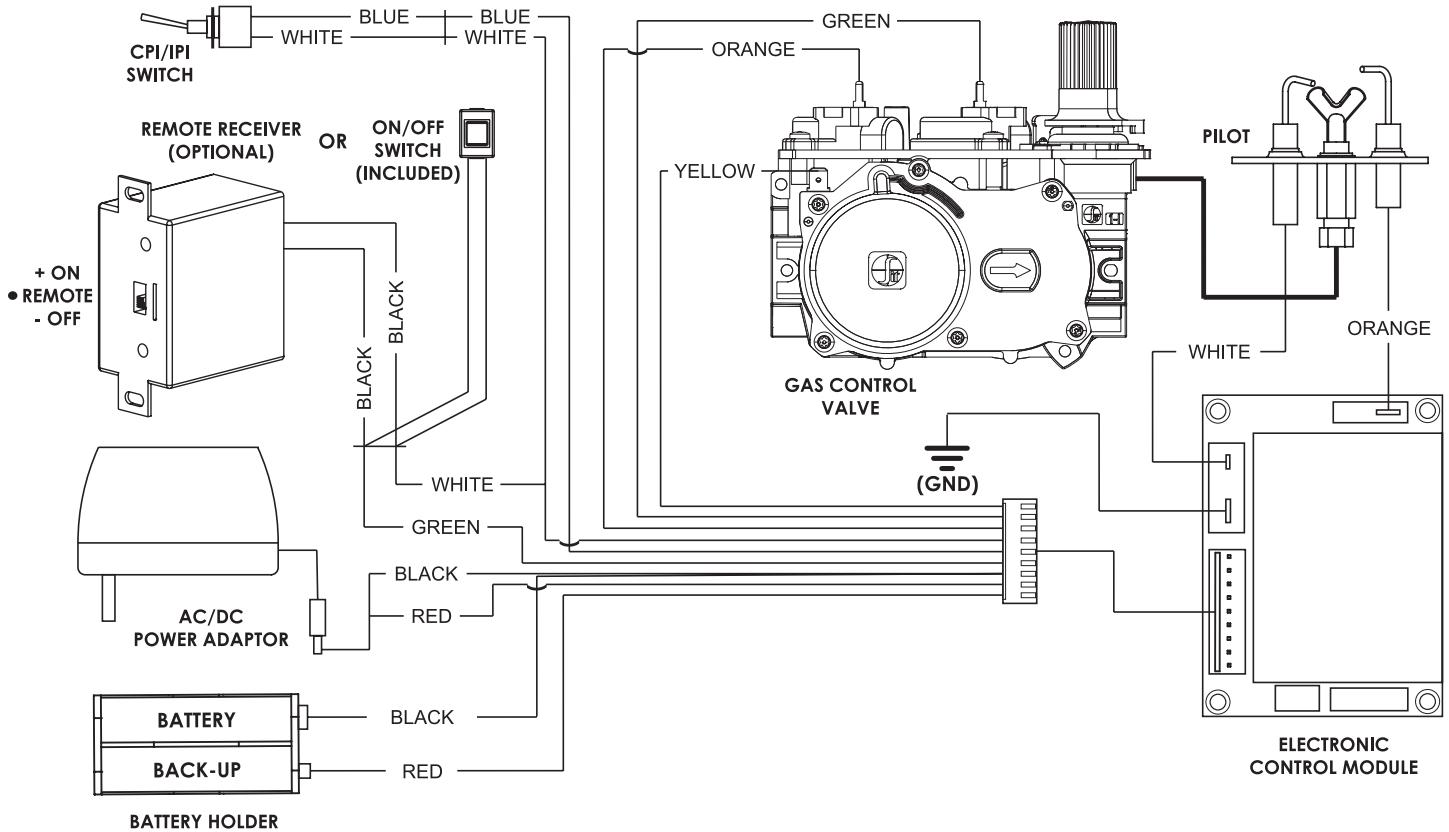


Figure 75

# INTERMITTENT PILOT ELECTRONIC SYSTEM WIRING DIAGRAM



If any of the original wire as supplied with this fireplace must be replaced, it must be replaced with equivalent gauge and temperature rated wire.

## ⚠ WARNING

### Electrical Grounding Instructions

This module is equipped with a three-prong (grounding) plug for your protection against shock hazard and should be plugged directly into a properly grounded three-prong receptacle. Do not cut or remove the grounding prong from this plug.

## ⚠ CAUTION

Label all wires prior to disconnection when servicing controls. Wiring errors can cause improper and dangerous operation.

## ⚠ CAUTION

Do not operate the fireplace with glass panel removed, cracked or broken. Replacement of the panel should be done by a licensed or qualified service person.

## ⚠ WARNING

Improper installation, adjustment, alteration, service or maintenance can cause property damage, personal injury or loss of life. Installation and service must be performed by a qualified installer, service agency or the gas supplier.

Verify proper operation after servicing.

# INTERMITTENT PILOT LIGHTING INSTRUCTIONS



## FOR YOUR SAFETY READ BEFORE LIGHTING

### ⚠ WARNING

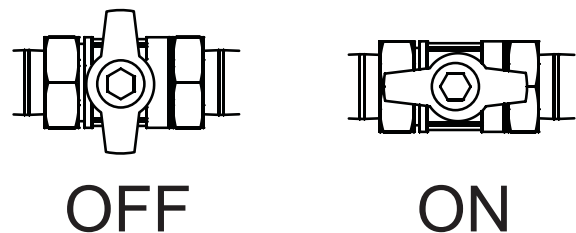
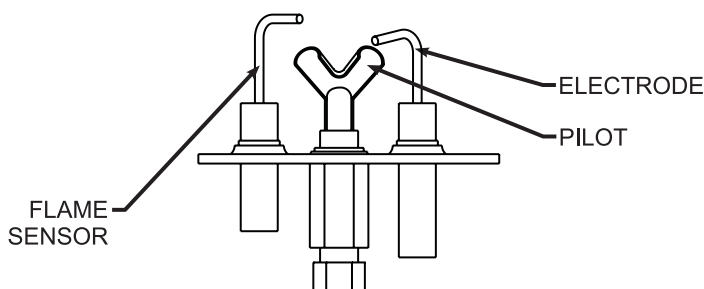
If you do not follow these instructions exactly, a fire or explosion may result causing property damage, personal injury or loss of life

- A. This appliance has a pilot which can be lighted with the manual on/off switch, a remote control, or by switching the receiver switch to the "ON" position. When lighting the pilot, follow these instructions exactly.
- B. BEFORE LIGHTING smell all around the appliance area for gas. Be sure to smell next to the floor because some gas is heavier than air and will settle on the floor.  
**WHAT TO DO IF YOU SMELL GAS**  
Do not try to light any appliance. Do not touch any electrical switch. Do not use any phone in your building. Immediately call your gas supplier from a neighbor's phone. Follow the gas supplier's instructions. If you can not reach your gas supplier, call the fire department.
- C. Use only the remote control or manual remote receiver switch to operate the gas valve. Never use tools. If valve does not operate, don't try to repair it, call a qualified service technician. Force or attempted repair may result in a fire or explosion.
- D. Do not use this appliance if any part has been under water. Immediately call a qualified service technician to inspect the appliance and to replace any part of the control system and any gas control which has been under water.


## LIGHTING INSTRUCTIONS

1. STOP! Read the safety information above.
2. Turn OFF electric power to the appliance.
3. Remove bottom access panel.
4. Turn gas cock counterclockwise  to "On" position.
5. Wait ten minutes to clear out any gas. Then smell for gas, including near the floor. If you smell gas, STOP! Follow "B" in the safety information above on this page. If you do not smell gas, go to the next step.
6. Turn ON electric power to the appliance.
7. Find pilot - Follow metal tube from gas control. The pilot is behind the burner on the right side.
8. Turn main flame to on. If the pilot does not light within 60 seconds, stop and go to Step 5.
9. Refer to remote control instructions for detailed information, control features, and operation. **NOTICE:** There is a CPI/IPI switch that allows for a continuous standing pilot mode or an intermittent pilot mode. See appliance manual for location of this switch. If the pilot or burner does not stay lit (in the standing pilot mode), stop and immediately call a qualified service technician or gas supplier.
10. If the burner or pilot does not operate properly after several tries, turn the gas cock clockwise  to "OFF" and call your service technician or gas supplier.
11. Replace bottom access panel.
12. Operation of the gas valve is controlled by a manual on/off switch or a hand held remote control. Refer to remote instructions for detailed operation information.

### GAS SHUT-OFF VALVE



## TO TURN OFF GAS TO FIREPLACE

1. Turn off all electric power to the appliance if service is to be performed (if applicable).
2. Gain access to control compartment. Remove surround panel assembly if necessary.
3. Locate On/Off gas cock and turn clockwise to  "OFF". Do not force.
4. Close bottom louver assembly, if included.



# INTERMITTENT PILOT CONTROL SYSTEM TROUBLESHOOTING

## Brief Description of the Components

The gas valve is fitted with a manual HI/LO knob to allow for manual modulation of the gas outlet pressure to the fireplace burner. The controls are designed to be used with either LPG or Natural Gas and can be converted by use of an OEM supplied conversion kit.

The Digital Fireplace Control (DFC) is an automatic gas ignition system based on a single micro-controller core. This control manages all functions related to ignition, flame sensing and supervision for atmospheric applications.

The DFC can be set to provide continuous or intermittent ignition control sequences and flame monitoring with safety shutdown in case of failure.

The DFC is set up as a stand alone (AC powered system with battery back up. See Lighting Instructions on page 64 and Wiring Diagram on page 63.

## Troubleshooting

Before proceeding with the procedures in the following troubleshooting table, verify that the power supply (AC/DC adapter) is present and that the batteries inside the receiver and/or optional battery pack are fresh and installed with correct polarity.

Make sure all the connections between the wire harnesses and system components are proper and positive.

Verify that the static inlet pressure meets the manufacturer's recommended inlet pressure. If necessary adjust the line pressure regulator.

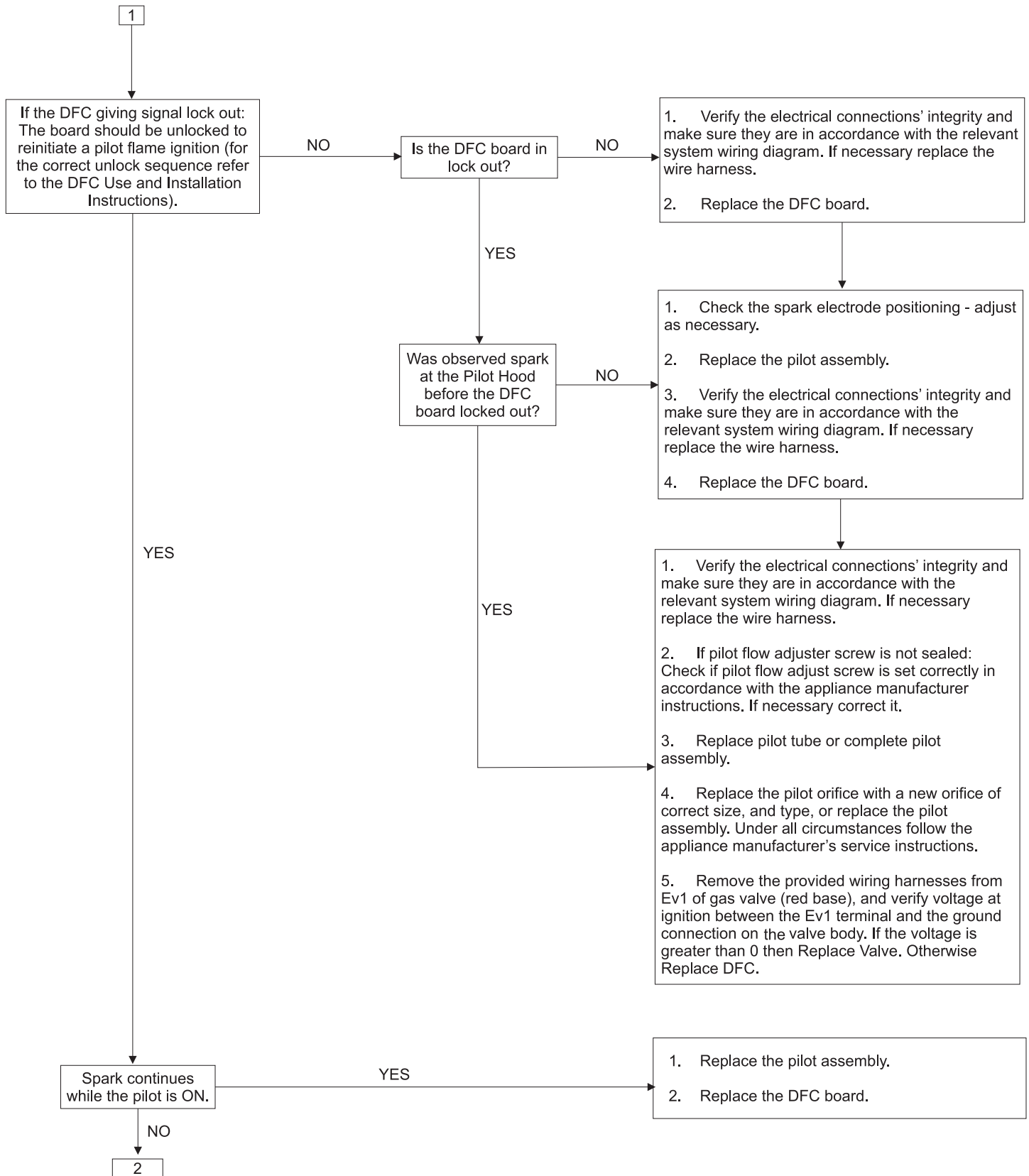
Check and clean the flame sensor.

If the recommended actions for the following troubleshooting chart do not help to address the problem consider replacing wiring harnesses.

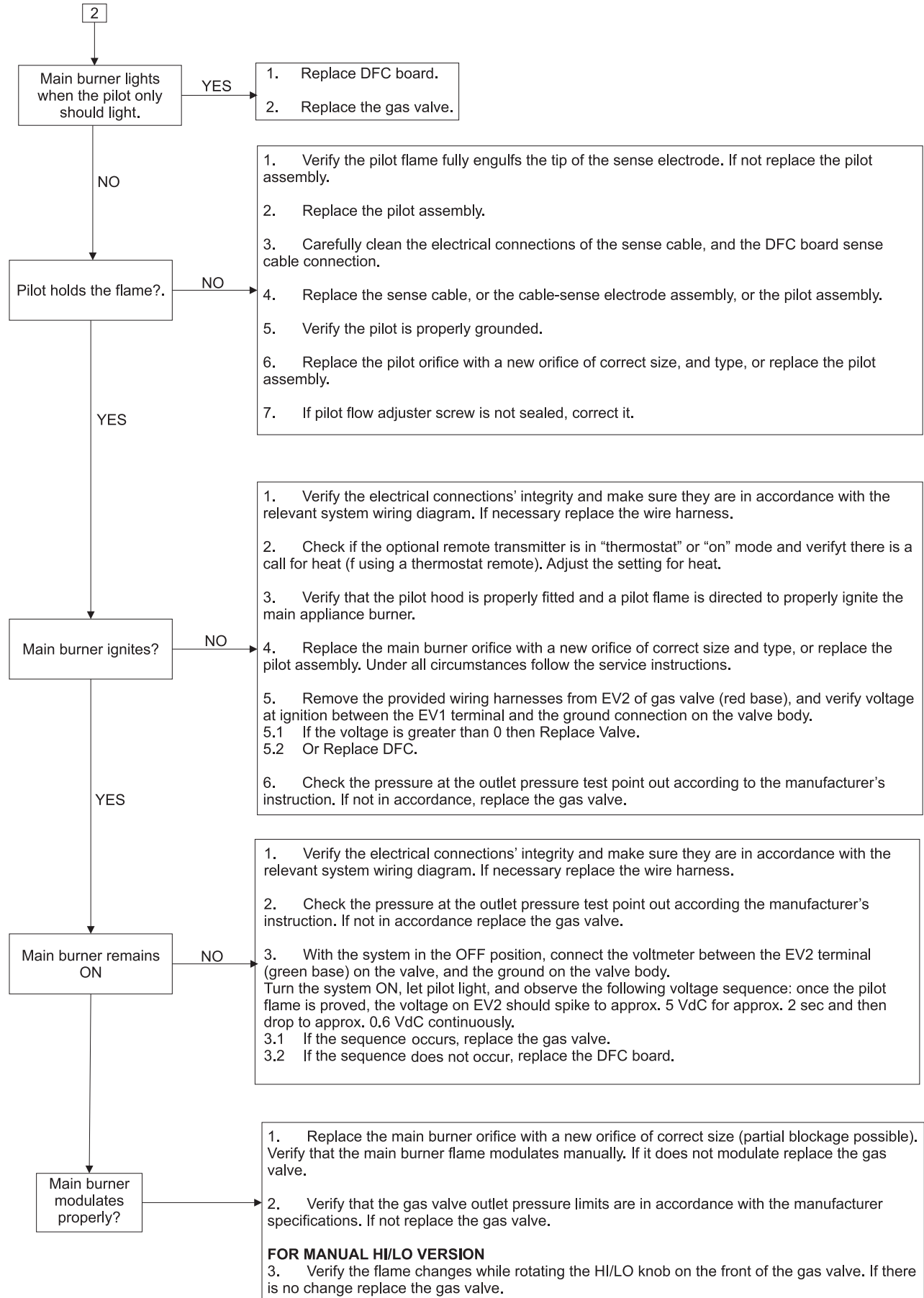
### **WARNING**

**Any actions performed on the gas valve must be in accordance with this instruction manual. Likewise, any actions performed on the DFC or other system components must be done in accordance with the individual component instructions. Replacement of components must be performed in accordance with this instructions manual.**

# INTERMITTENT PILOT CONTROL SYSTEM TROUBLESHOOTING



# INTERMITTENT PILOT CONTROL SYSTEM TROUBLESHOOTING



# MAINTENANCE AND SERVICE

## Wiring

If any of the original wire as supplied with this fireplace must be replaced, it must be replaced with no. 18, 150°C wire or its equivalent.

### NOTICE

**It is normal for fireplaces fabricated of steel to give off some expansion and/or contraction noise during the start up or cool down cycle. Similar noises are found with your furnace heat exchanger or car engine.**

**It is normal for your gas fireplace to give off some odor the first time it is burned. This is due to the curing of the paint and any undetected oil from the manufacturing process. Please ensure that your room is well ventilated - open a window.**

Please ensure that your room is well ventilated - open all windows.

**It is recommended that you burn your fireplace for at least six hours the first time you use it. If optional fan kit has been installed, place fan in the "OFF" position during this time.**

**IMPORTANT:** Turn off gas before servicing fireplace. It is recommended that a qualified service person perform these check-ups at the beginning of each heating season.

#### • Clean Burner and Control Compartment

Keep the control compartment, logs, and burner areas surrounding the logs clean by vacuuming or brushing at least twice a year.

## Cleaning Procedure

1. Turn off pilot light at gas valve.
  2. Remove glass front. (See Glass Removal)
  3. Vacuum burner compartment.
  4. Reinstall glass front.
  5. Ignite pilot. (See Lighting Instructions)
  6. Operate the pilot burner. If it appears abnormal call a service person.
- Any safety screen, guard, or barrier removed to service a fireplace must be replaced prior to operating the fireplace.

#### • Check Vent System

The fireplace and venting system should be inspected before initial use and at least annually by a qualified service person. Inspect the external vent cap on a regular basis to make sure that no debris is interfering with the air flow.

## Glass Cleaning

### ⚠ WARNING

**Do not use Ammonia based or abrasive cleaners on glass. Do not attempt to clean glass when glass is hot.**

It will be necessary to clean the glass periodically. During start-up condensation, which is normal, forms on the inside of the glass and causes lint, dust and other airborne particles to cling to the glass surface. Also initial paint curing may deposit a slight film on the glass. It is therefore recommended that the glass be cleaned two or three times with a non-abrasive household cleaner and warm water (we recommend gas fireplace glass cleaner). After that clean the glass two or three times during each heating season or more often if necessary.

## General Glass Information

### ⚠ WARNING

**Do not operate fireplace with the glass front removed, cracked or broken.**

Only glass approved for use by the manufacturer in fireplace may be used for replacement. The glass replacement should be done by a licensed or qualified service person.

### ⚠ WARNING

1. **The use of substitute glass will void all product warranties.**
2. **Care must be taken to avoid breakage of the glass.**
3. **Under no circumstances should this fireplace be operated without the glass front or with a broken glass front. Replacement of the glass (with gasket) as supplied by the manufacturer should be done by a qualified service person.**
4. **Do not abuse the glass by striking or hitting the glass.**

# MAINTENANCE AND SERVICE

## Glass Removal and Replacement

1. Remove bottom access panel.
2. Release two glass frame clamps at bottom of firebox.
3. Remove glass frame and screen frames as a unit.
4. Place glass and screen frames onto firebox.
5. Attach two glass frame clamps at bottom of firebox.
6. Replace access panel.

### WARNING

Do not operate fireplace with the glass front removed, cracked, or broken. Replacement of the glass should be done by a licensed or qualified service person.

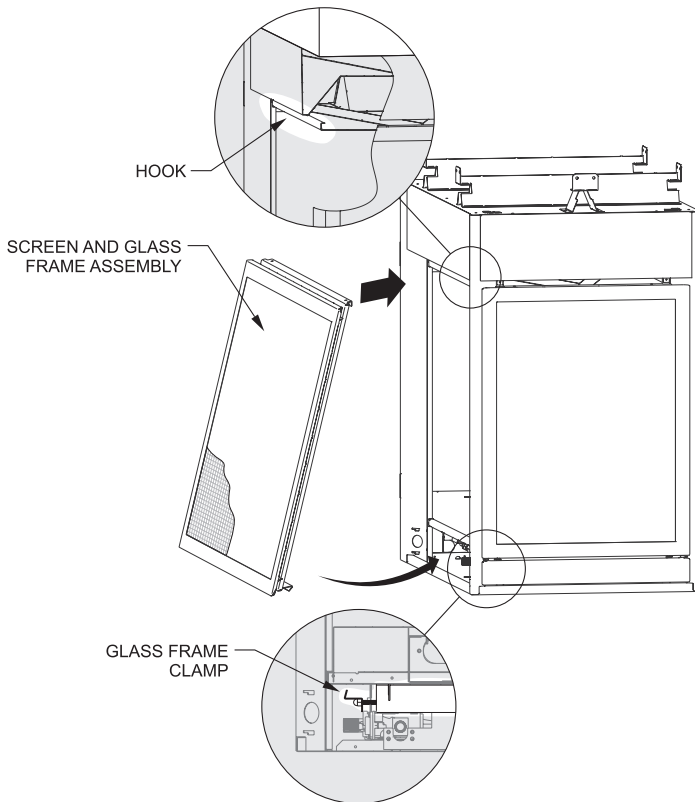


Figure 76

## Separating Screen Frame From Glass Frame

1. Turn glass and screen frame assembly upside down and rest the glass frame on a block of wood, step, or similar object.
2. Push downwards on screen frame to release the tabs from the glass frame.

Note: When reattaching screen frame to glass frame, orient the screen frame so that the tabs with notches are on the top side of the glass frame.

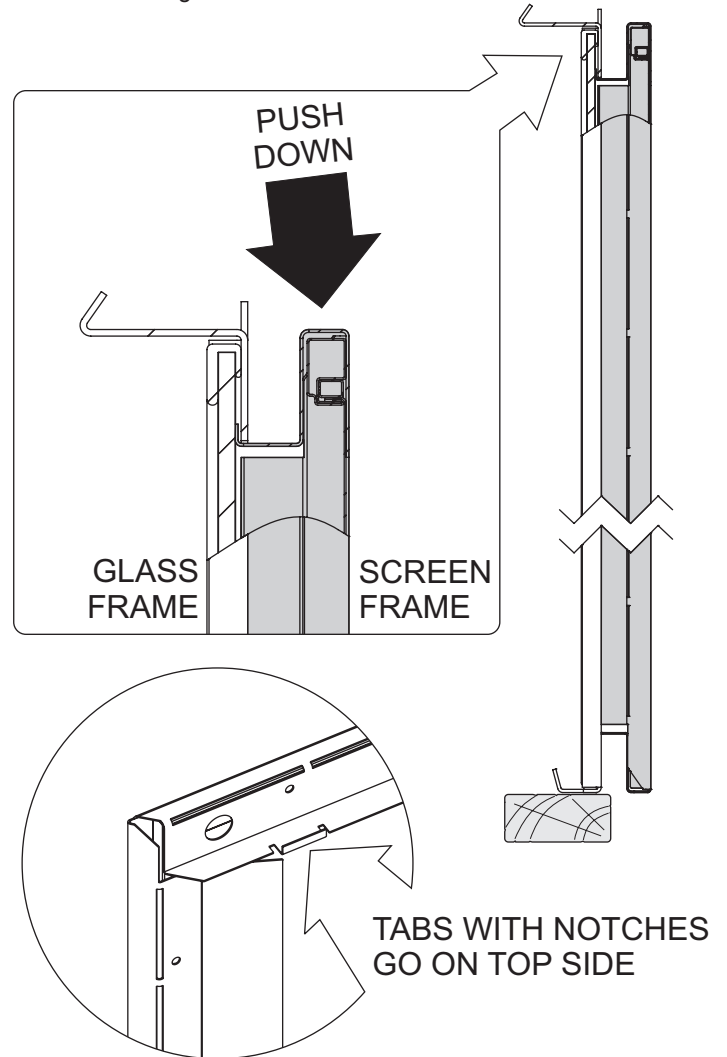
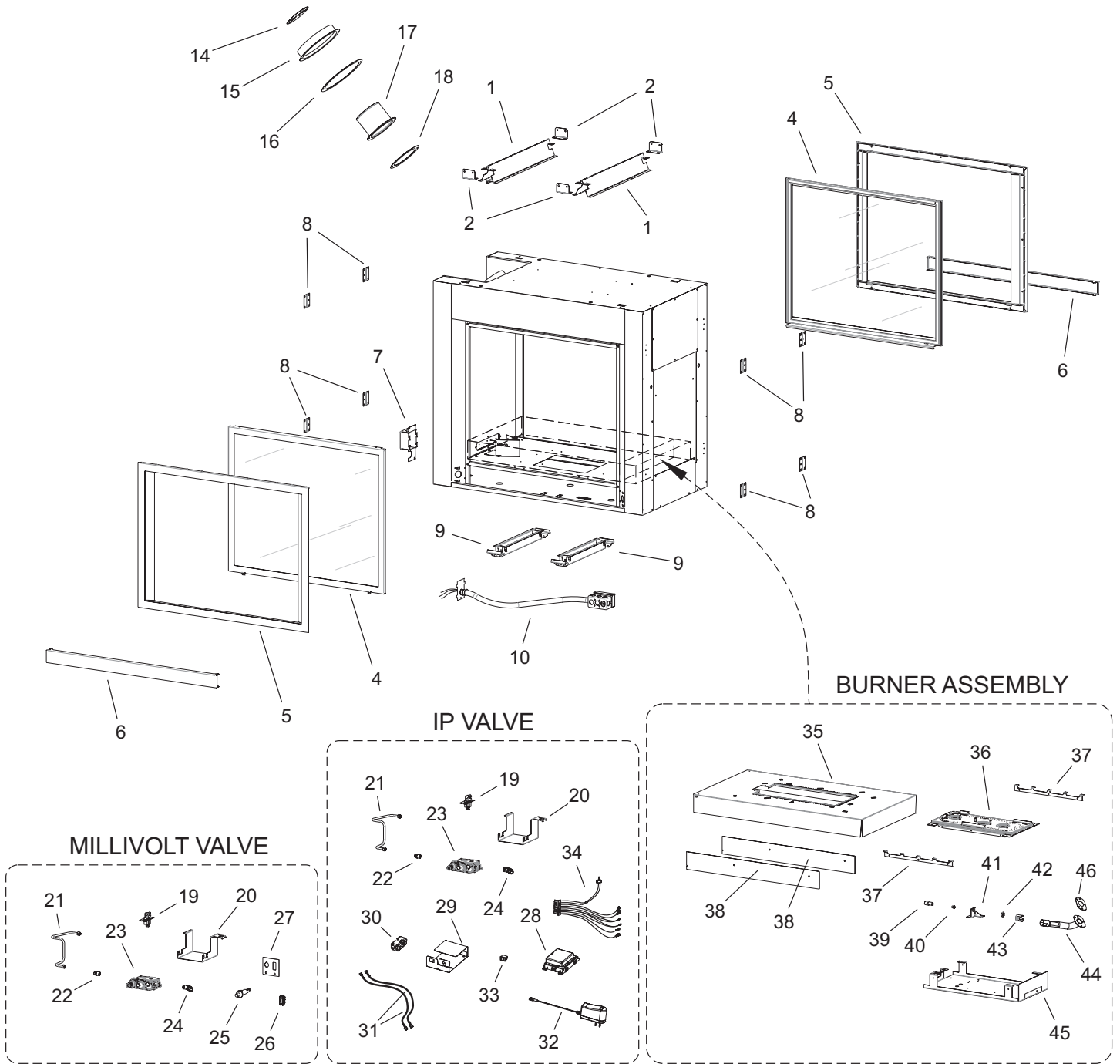


Figure 77

# SEE-THRU PARTS VIEW



## ⚠ WARNING

Failure to position the parts in accordance with these diagrams or failure to use only parts specifically approved with this appliance may result in property damage or personal injury.

# SEE-THRU PARTS LIST

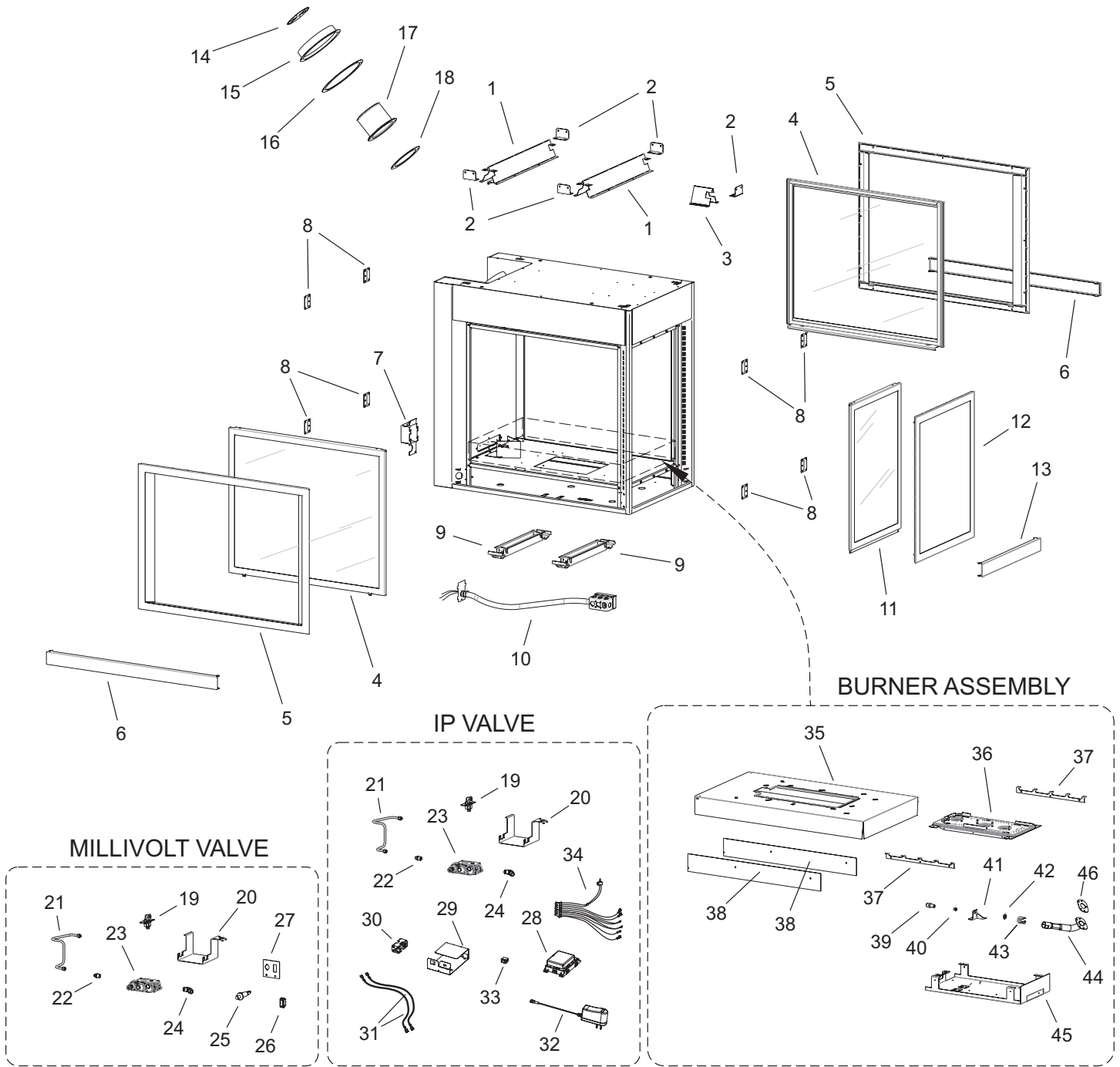
INDEX NO.	NG	LP	DESCRIPTION
	PART NUMBER		
1	36051	36051	STAND-OFF, LONG
2	36053	36053	NAILING FLANGE, TOP
4	36074	36074	GLASS FRAME ASSEMBLY
5	36076	36076	SCREEN FRAME ASSEMBLY
6	34139	34139	ACCESS PANEL, LONG
7	36086	36086	OUTSIDE JUNCTION BOX ASSEMBLY
8	31579	31579	NAILING FLANGE
9	36089	36089	DOUBLE GLASS LATCH
10	36085	36085	JUNCTION BOX AND CONDUIT
14	34054	34529	FLUE BAFFLE
15	R7567	R7567	INLET VENT ADAPTER
16	R5773	R5773	GASKET, INLET VENT
17	30975	30975	FLUE OUTLET
18	M170	M170	FLUE GASKET
19	R7612	R7611	PILOT ASSEMBLY, MV
19	R10423	R10424	PILOT ASSEMBLY, IP
20	36060	36060	VALVE BRACKET
21	35038	35038	BURNER TUBE
22	R2423	R2423	5/16 TUBE FITTING, STRAIGHT
23	R7577	R7578	VALVE, MV
23	R11125	R11126	VALVE, IP
24	R10882	R10882	ELBOW, 3/8 NPT X 3/8 FLARE
25	R9760	R9760	PIEZO IGNITOR
26	R3436	R3436	SWITCH
27	36045	36045	PIEZO AND SWITCH BRACKET

INDEX NO.	NG	LP	DESCRIPTION
	PART NUMBER		
28	R11127	R11127	CONTROL BOARD / MODULE
29	29382	29382	MODULE TRAY
30	R11122	R11122	BATTERY HOLDER
31	R2566	R2566	WIRE ASSEMBLY, ORANGE & BLACK
32	R11128	R11128	AC ADAPTER
33	R2522	R2522	SWITCH, ON/OFF
34	R11123	R11123	PROFLAME WIRE HARNESS
35*	35281	35281	FALSE FLOOR (STONES)
35*	36056	36056	FALSE FLOOR
36	36087	36087	BURNER WELDMENT
37	34826	34826	FALSE FLOOR SUPPORT
38	34699	34699	BURNER AIR GUIDE
39	R11675	R11675	ORIFICE HOLDER
40	P244 (#33)	P210 (#51)	ORIFICE
41	34933	34933	ORIFICE BRACKET
42	R7572	R7572	JAMB NUT
43	R7624	R7624	AIR SHUTTER
44	R11978	R11978	VENTURI
45	36057	36057	BURNER BASE
46	R11977	R11977	VENTURI GASKET

\* False floor ships with log set or mixed logs and rock set.

MILLIVOLT ITEMS ONLY - NOT SHOWN	
PART NUMBER	DESCRIPTION
R9825	ELECTRODE
R9824	THERMOPILE
R9823	THERMOCOUPLE
R9826	PILOT TUBING

# PENINSULA PARTS VIEW



**⚠ WARNING**

Failure to position the parts in accordance with these diagrams or failure to use only parts specifically approved with this appliance may result in property damage or personal injury.



# PENINSULA PARTS LIST

INDEX NO.	PART NUMBER		DESCRIPTION
	NG	LP	
1	36051	36051	STAND-OFF, LONG
2	36053	36053	NAILING FLANGE, TOP
3	36052	36052	STAND-OFF, SHORT
4	36074	36074	GLASS FRAME ASSEMBLY
5	36076	36076	SCREEN FRAME ASSEMBLY
6	34139	34139	ACCESS PANEL, LONG
7	36086	36086	OUTSIDE JUNCTION BOX ASSEMBLY
8	31579	31579	NAILING FLANGE
9	36089	36089	DOUBLE GLASS LATCH
10	36085	36085	JUNCTION BOX AND CONDUIT
11	36075	36075	GLASS FRAME, SHORT
12	36077	36077	SCREEN FRAME, SHORT
13	34140	34140	ACCESS PANEL, SHORT
14	34054	34529	FLUE BAFFLE
15	R7567	R7567	INLET VENT ADAPTER
16	R5773	R5773	GASKET, INLET VENT
17	30975	30975	FLUE OUTLET
18	M170	M170	FLUE GASKET
19	R7612	R7611	PILOT ASSEMBLY, MV
19	R10423	R10424	PILOT ASSEMBLY, IP
20	36060	36060	VALVE BRACKET
21	35038	35038	BURNER TUBE
22	R2423	R2423	5/16 TUBE FITTING, STRAIGHT
23	R7577	R7578	VALVE, MV
23	R11125	R11126	VALVE, IP

INDEX NO.	PART NUMBER		DESCRIPTION
	NG	LP	
24	R10882	R10882	ELBOW, 3/8 NPT X 3/8 FLARE
25	R9760	R9760	PIEZO IGNITOR
26	R3436	R3436	SWITCH
27	36045	36045	PIEZO AND SWITCH BRACKET
28	R11127	R11127	CONTROL BOARD / MODULE
29	29382	29382	MODULE TRAY
30	R11122	R11122	BATTERY HOLDER
31	R2566	R2566	WIRE ASSEMBLY, ORANGE & BLACK
32	R11128	R11128	AC ADAPTER
33	R2522	R2522	SWITCH, ON/OFF
34	R11123	R11123	PROFLAME WIRE HARNESS
35*	35281	35281	FALSE FLOOR (STONES)
35*	36056	36056	FALSE FLOOR
36	36087	36087	BURNER WELDMENT
37	34826	34826	FALSE FLOOR SUPPORT
38	34699	34699	BURNER AIR GUIDE
39	R11675	R11675	ORIFICE HOLDER
40	P244 (#33)	P210 (#51)	ORIFICE
41	34933	34933	ORIFICE BRACKET
42	R7572	R7572	JAMB NUT
43	R7624	R7624	AIR SHUTTER
44	R11978	R11978	VENTURI
45	36057	36057	BURNER BASE
46	R11977	R11977	VENTURI GASKET

\* False floor ships with log set or mixed logs and rock set.

MILLIVOLT ITEMS ONLY - NOT SHOWN	
PART NUMBER	DESCRIPTION
R9825	ELECTRODE
R9824	THERMOPILE
R9823	THERMOCOUPLE
R9826	PILOT TUBING

# MASTER PARTS DISTRIBUTOR LIST

To Order Parts Under Warranty, please contact your local Empire dealer. See the dealer locator at [www.empirecomfort.com](http://www.empirecomfort.com). To provide warranty service, your dealer will need your name and address, purchase date and serial number, and the nature of the problem with the fireplace.

To Order Parts After the Warranty Period, please contact your dealer or one of the Master Parts Distributors listed below. This list changes from time to time. For the current list, please click on the Master Parts button at [www.empirecomfort.com](http://www.empirecomfort.com).

Please note: Master Parts Distributors are independent businesses that stock the most commonly ordered Original Equipment repair parts for Heaters, Grills, and Fireplaces manufactured by Empire Comfort Systems Inc.

## Dey Distributing

1401 Willow Lake Boulevard  
Vadnais Heights, MN 55101

**Phone:** 651-490-9191

**Toll Free:** 800-397-1339

**Website:** [www.deydistributing.com](http://www.deydistributing.com)

**Parts:** Heater, Hearth and Grills

## F. W. Webb Company

200 Locust Street  
Hartford, CT 06114

**Phone:** 860-722-2433

**Toll Free:** 800-243-9360

**Fax:** 860-293-0479

**Toll Free Fax:** 800-274-2004

**Websites:** [www.fwwebb.com](http://www.fwwebb.com) & [www.victormfg.com](http://www.victormfg.com)

**Parts:** Heater, Hearth and Grills

## East Coast Energy Products

10 East Route 36  
West Long Branch, NJ 07764

**Phone:** 732-870-8809

**Toll Free:** 800-755-8809

**Fax:** 732-870-8811

**Website:** [www.eastcoastenergy.com](http://www.eastcoastenergy.com)

**Parts:** Heater, Hearth and Grills

# HOW TO ORDER REPAIR PARTS

## Parts Not Under Warranty

Parts can be ordered through your Service Person, Dealer, or a Master Parts Distributor. See this page for the Master Parts Distributors list. For best results, the **service person or dealer** should order parts through the distributor. Parts can be shipped directly to the **service person/dealer**.

## Warranty Parts

Warranty parts will need a proof of purchase and can be ordered by your Service Person or Dealer. Proof of purchase is **required** for warranty parts.

All parts listed in the Parts List have a Part Number. When ordering parts, first obtain the Model Number and Serial Number from the name plate on your equipment. Then determine the Part Number (**not** the Index Number) and the Description of each part from the following illustration and part list. Be sure to give all this information . . .

Fireplace Model Number \_\_\_\_\_ Part Description \_\_\_\_\_

Fireplace Serial Number \_\_\_\_\_ Part Number \_\_\_\_\_

Type of Gas (Propane or Natural) \_\_\_\_\_

Do not order bolts, screws, washers or nuts. They are standard hardware items and can be purchased at any local hardware store.

Shipments contingent upon strikes, fires and all causes beyond our control.

# IMPORTANT SAFETY INFORMATION

## WARNING

Read and follow these safety precautions prior to operating this fireplace. Failure to follow these precautions may result in death, injury, or property damage.

### Safety Precautions

**Before enclosing the vent pipe assembly, operate the fireplace to ensure it is venting properly.**

## CAUTION

If the glass used in your fireplace is cracked or damaged in any way, it should be replaced only with a complete glass frame assembly from Empire. See parts list on Pages 70 to 73 for ordering.

## WARNING

**HIGH SURFACE TEMPERATURES - This fireplace may become hot enough to burn skin and ignite clothing after prolonged contact. To prevent injury or property damage, caution people to stay clear and avoid touching the fireplace.**

- The vent cap, located on the outside of your home, will become very hot. Alert everyone, adults and children, to stay clear and avoid touching the vent cap. Keep the area around the vent cap clear of combustibles, including shrubs and trees.
- Locate fireplace out of high traffic areas and away from furniture and draperies.
- Always keep the fireplace area clear and free from combustible material (including drapery, upholstered furniture, paper, boxes and clothing), gasoline and other flammable vapors and liquids.
- Alert children and adults to the hazards of high surface temperature. Keep away from the fireplace to avoid burns or clothing ignition.
- Carefully supervise young children and at-risk individuals when they are in the same room as the fireplace. Toddlers, young children, and others may be susceptible to accidental contact burns. A physical barrier is recommended if there are at-risk individuals in the house. Install an adjustable safety gate to restrict access to the fireplace, hot surfaces, or to block entry to the room.

- If this fireplace is installed directly on carpeting, tile or other combustible material other than wood flooring, the fireplace must be installed on a metal or wood panel extending the full width and depth of the fireplace.  
The base referred to above does not mean the fireproof base as used on wood stoves. The protection is for rugs that are extremely thick and light colored tile.
- This fireplace must not share or be connected to a flue serving a separate solid-fuel burning fireplace.
- **Under no circumstances** should any solid fuels (wood, coal, paper or cardboard etc.) be used in this fireplace.
- This fireplace requires an unimpeded flow of air to circulate warm air. Do not place objects on or around the fireplace that may restrict air flow to or from the fireplace.
- The glass front or any part removed for servicing the

fireplace must be replaced prior to operating the fireplace. Work should be done by a qualified service person.

- A barrier designed to reduce the risk of burns from the hot viewing glass is provided with this fireplace and shall be installed for the protection of children and other at-risk individuals.
- Any safety screen, guard, or barrier removed to service a fireplace must be replaced prior to operating the fireplace.
- If the barrier becomes damaged, the barrier shall be replaced with the manufacturer's barrier for this fireplace.
- Only trim kit(s) supplied by the manufacturer shall be used in the installation of this fireplace.
- Installation and repair should be done by a qualified service person. The fireplace should be inspected before use and at least annually by a qualified service person. More frequent cleaning may be required due to excessive lint from carpeting, bedding material, etc. It is imperative that control compartments, burners and circulating air passageways of the fireplace be kept clean.
- Keep burner and control compartment clean.
- Examine venting system periodically and replace damaged parts.
- Make a periodic visual check of pilot and burners. Clean and replace damaged parts.
- Do not use this fireplace if any part has been under water. Immediately call a qualified service technician to inspect the fireplace and to replace any part of the control system and any gas control which has been under water.
- In the event of a natural disaster (tornado, earthquake, fire, etc.), have a qualified technician inspect the fireplace for damage or potential gas leaks. Repair or replace any damaged components before operating this fireplace.
- Do not place debris or other articles on the log set during operation.
- Keep burner and control compartment clean.
- A qualified service person must perform installation and repair. A qualified service person must inspect the fireplace before use and at least annually. More frequent cleaning may be required due to excessive lint from carpeting, bedding materials, hair from pets, etc. It is imperative that control compartments, burners and circulating air passageways of the fireplace be kept clean.
- **Do not** put anything around the fireplace that will obstruct the flow of ventilation air.
- Keep the fireplace area clear and free from combustible material, gasoline and other flammable vapors and liquids.
- A qualified service agency must perform a yearly examination and clean the venting system of the solid-fuel burning fireplace.
- Make a periodic visual check of pilot and burners. Clean and replace damaged parts.
- **Do not** use this fireplace if any part has been under water. Immediately call a qualified service technician to inspect the fireplace and to replace any part of the control system and any gas control which has been under water.

# SAFETY INFORMATION FOR USERS OF LP GAS

Propane (LP-Gas) is a flammable gas which can cause fires and explosions. In its natural state, propane is odorless and colorless. You may not know all the following safety precautions which can protect both you and your family from an accident. Read them carefully now, then review them point by point with the members of your household. Someday when there may not be a minute to lose, everyone's safety will depend on knowing exactly what to do. If, after reading the following information, you feel you still need more information, please contact your gas supplier.

## LP-GAS WARNING ODOR

**If a gas leak happens, you should be able to smell the gas because of the odorant put in the LP-Gas. That's your signal to go into immediate action!**

- Do not operate electric switches, light matches, or use your phone. Do not do anything that could ignite the gas.
- Get everyone out of the building, vehicle, trailer, or area. Do that IMMEDIATELY.
- Close all gas tank or cylinder supply valves.
- LP-Gas is heavier than air and may settle in low areas such as basements. When you have reason to suspect a gas leak, keep out of basements and other low areas. Stay out until firefighters declare them to be safe.
- Use your neighbor's phone and call a trained LP-Gas service person and the fire department. Even though you may not continue to smell gas, do not turn on the gas again. Do not re-enter the building, vehicle, trailer, or area.
- **Finally**, let the service man and firefighters check for escaped gas. Have them air out the area before you return. Properly trained LP-Gas service people should repair the leak, then check and relight the gas fireplace for you.

## NO ODOR DETECTED - ODOR FADE

**Some people cannot smell well. Some people cannot smell the odor of the chemical put into the gas. You must find out if you can smell the odorant in propane.** Smoking can decrease your ability to smell. Being around an odor for a time can affect your sensitivity or ability to detect that odor. Sometimes other odors in the area mask the gas odor. People may not smell the gas odor or their minds are on something else. Thinking about smelling a gas odor can make it easier to smell.

**The odorant in LP-Gas is colorless, and it can fade under some circumstances.** For example, if there is an underground leak, the movement of the gas through soil can filter the odorant. Odorants in LP-Gas also are subject to oxidation. This fading can occur if there is rust inside the storage tank or in iron gas pipes. The odorant in escaped gas can adsorb or absorb onto or into walls, masonry and other materials and fabrics in a room. That will take some of the odorant out of the gas, reducing its odor intensity.

LP-Gas may stratify in a closed area, and the odor intensity could vary at different levels. Since it is heavier than air, there may be more odor at lower levels. Always be sensitive to the slightest gas odor. If you detect any odor, treat it as a serious leak. Immediately go into action as instructed earlier.

## SOME POINTS TO REMEMBER

- **Learn to recognize the odor of LP-Gas.** Your local LP-Gas Dealer can give you a "Scratch and Sniff" pamphlet. Use it to find out what the propane odor smells like. If you suspect that your LP-Gas has a weak or abnormal odor, call your LP-Gas Dealer.
- If you are not qualified, do not light pilot lights, perform service, or make adjustments to appliances on the LP-Gas system. If you are qualified, consciously think about the odor of LP-Gas prior to and while lighting pilot lights or performing service or making adjustments.
- Sometimes a basement or a closed-up house has a musty smell that can cover up the LP-Gas odor. Do not try to light pilot lights, perform service, or make adjustments in an area where the conditions are such that you may not detect the odor if there has been a leak of LP-Gas.
- Odor fade, due to oxidation by rust or adsorption on walls of new cylinders and tanks, is possible. Therefore, people should be particularly alert and careful when new tanks or cylinders are placed in service. Odor fade can occur in new tanks, or reinstalled old tanks, if they are filled and allowed to set too long before refilling. Cylinders and tanks which have been out of service for a time may develop internal rust which will cause odor fade. If such conditions are suspected to exist, a periodic sniff test of the gas is advisable. **If you have any question about the gas odor, call your LP-Gas dealer. A periodic sniff test of the LP-Gas is a good safety measure under any condition.**
- If, at any time, you do not smell the LP-Gas odorant and you think you should, assume you have a leak. Then take the same immediate action recommended above for the occasion when you do detect the odorized LP-Gas.
- If you experience a complete "gas out," (the container is under no vapor pressure), turn the tank valve off immediately. If the container valve is left on, the container may draw in some air through openings such as pilot light orifices. If this occurs, some new internal rusting could occur. If the valve is left open, then treat the container as a new tank. Always be sure your container is under vapor pressure by turning it off at the container before it goes completely empty or having it refilled before it is completely empty.

# REQUIREMENTS FOR MASSACHUSETTS

For all side wall horizontally vented gas fueled equipment installed in every dwelling, building or structure used in whole or in part for residential purposes, including those owned or operated by the Commonwealth and where the side wall exhaust vent termination is less than seven feet above finished grade in the area of the venting, including but not limited to decks and porches, the following requirements shall be satisfied:

1. **INSTALLATION OF CARBON MONOXIDE DETECTORS.**  
At the time of installation of the side wall horizontal vented gas fueled equipment, the installing plumber or gasfitter shall observe that a hard wired carbon monoxide detector with an alarm and battery back-up is installed on the floor level where the gas equipment is to be installed. In addition, the installing plumber or gasfitter shall observe that a battery operated or hard wired carbon monoxide detector with an alarm is installed on each additional level of the dwelling, building or structure served by the side wall horizontal vented gas fueled equipment. It shall be the responsibility of the property owner to secure the services of qualified licensed professionals for the installation of hard wired carbon monoxide detectors
  - a. In the event that the side wall horizontally vented gas fueled equipment is installed in a crawl space or an attic, the hard wired carbon monoxide detector with alarm and battery back-up may be installed on the next adjacent floor level.
  - b. In the event that the requirements of this subdivision can not be met at the time of completion of installation, the owner shall have a period of thirty days to comply with the above requirements; provided, however, that during said thirty day period, a battery operated carbon monoxide detector with an alarm shall be installed.
2. **APPROVED CARBON MONOXIDE DETECTORS.** Each carbon monoxide detector as required in accordance with the above provisions shall comply with NFPA 720 and be ANSI/UL 2034 listed and IAS certified.
3. **SIGNAGE.** A metal or plastic identification plate shall be permanently mounted to the exterior of the building at a minimum height of eight feet above grade directly in line with the exhaust vent termination for the horizontally vented gas fueled heating appliance or equipment. The sign shall read, in print size no less than 1/2 inch in size, **"GAS VENT DIRECTLY BELOW. KEEP CLEAR OF ALL OBSTRUCTIONS"**.
4. **INSPECTION.** The state or local gas inspector of the side wall horizontally vented gas fueled equipment shall not approve the installation unless, upon inspection, the inspector observes carbon monoxide detectors and signage installed in accordance with the provisions of 248 CMR 5.08(2)(a) 1 through 4.
  - (b) **EXEMPTIONS:** The following equipment is exempt from 248 CMR 5.08(2)(a)1 through 4:
    1. The equipment listed in Chapter 10 entitled "Equipment Not Required To Be Vented" in the most current edition of NFPA 54 as adopted by the Board; and
    2. Product Approved side wall horizontally vented gas fueled equipment installed in a room or structure separate from the dwelling, building or structure used in whole or in part for residential purposes.
  - (d) **MANUFACTURER REQUIREMENTS - GAS EQUIPMENT VENTING SYSTEM NOT PROVIDED.** When the manufacturer of a Product Approved side wall horizontally vented gas fueled equipment does not provide the parts for venting the flue gases, but identifies "special venting systems", the following requirements shall be satisfied by the manufacturer:
    1. The referenced "special venting system" instructions shall be included with the appliance or equipment installation instructions; and
    2. The "special venting systems" shall be Product Approved by the Board, and the instructions for that system shall include a parts list and detailed installation instruction.
  - (e) A copy of all installation instructions for all Product Approved side wall horizontally vented gas fueled equipment, all venting instructions, all parts lists for venting instructions, and/or all venting design instructions shall remain with the appliance or equipment at the completion of the installation.



# WARRANTY

Empire Comfort Systems Inc. warrants this hearth product to be free from defects at the time of purchase and for the periods specified below. Hearth products must be installed by a qualified technician and must be maintained and operated safely, in accordance with the instructions in the owner's manual. This warranty applies to the original purchaser only and is not transferable. All warranty repairs must be accomplished by a qualified gas appliance technician.

## **Limited Lifetime Parts Warranty – Combustion Chamber, Heat Exchanger, and Factory-Installed Glass**

- If the combustion chamber, heat exchanger (see parts list) or factory-installed glass fails because of defective workmanship or material, Empire will repair or replace at Empire's option.

## **Limited Three-Year Parts Warranty – All Other Components (Except Remote Controls, Thermostats, Accessories and Replacement Parts)**

- Should any part fail because of defective workmanship or material within three years from the date of purchase, Empire will repair or replace at Empire's option.

## **Limited One-Year Parts Warranty – Remote Controls, Thermostats, Accessories, and Parts**

- Should any remote control, thermostat, accessory, or other part fail because of defective workmanship within one year from the date of purchase, Empire will repair or replace at Empire's option.

## **Duties of the Owner**

- The appliance must be installed by a qualified installer and operated in accordance with the instructions furnished with the appliance.
- A bill of sale, cancelled check, or payment record should be kept to verify purchase date and establish warranty period.
- Ready access to the appliance for service.

## **What Is Not Covered**

- Damages that might result from the use, misuse, or improper installation of this appliance.
- Travel, diagnostic costs and freight charges on warranted parts to and from the factory.
- Claims that do not involve defective workmanship or materials.
- Unauthorized service or parts replacements.
- Removal and reinstallation cost.
- Inoperable due to improper or lack of maintenance.

## **How To Get Service**

- To make a claim under this warranty, please have your receipt available and contact your installing dealer. Provide the dealer with the model number, serial number, type of gas, and purchase verification. The installing dealer is responsible for providing service and will contact the factory to initiate any warranted parts replacements. Empire will make replacement parts available at the factory. Shipping expenses are not covered.
- If, after contacting your Empire dealer, service received has not been satisfactory, contact: Consumer Relations Department, Empire Comfort Systems Inc., PO Box 529, Belleville, Illinois 62222, or send an e-mail to [info@empirecomfort.com](mailto:info@empirecomfort.com) with "Consumer Relations" in the subject line.

## **Your Rights Under State Law**

- This warranty gives you specific legal rights, and you may also have other rights, which vary from state to state.



**Empire Comfort Systems Inc.  
Belleville, IL**

If you have a general question  
about our products, please e-mail  
us at [info@empirecomfort.com](mailto:info@empirecomfort.com).

If you have a service or repair  
question, please contact your dealer.

SINCE 1932

**[www.empirecomfort.com](http://www.empirecomfort.com)**