

---

# New Buck Corporation

Project # 037-S-048-6 B

Model: 21NC

Type: Free Standing Residential  
Non-catalytic Wood Fired Heater

September 16, 2016

---

## Test Method 28R for Certification and Auditing of Wood Heaters

---

Contact:

Mr. David Honeycutt

200 Ethan Allen Dr

Spruce Pine, NC 28777

[dhoneycutt@buckstove.com](mailto:dhoneycutt@buckstove.com)

(828) 765-6144

---

Prepared by: Doug Towne, QA Manager

---



**11785 SE Highway 212 – Suite 305**

**Clackamas, OR 97015-9050**

**(503) 650-0088**

**[WWW.DIRIGOLAB.COM](http://WWW.DIRIGOLAB.COM)**

## Revision History:

September 2016: Original Issue

November 18, 2021

- Added CO in g/min- Page 8 & 12
- Negative weight statement- Page 16
- Firebox volume diagram added– Page 18
- Dual Train precision validity table- Page 17
- Stated missing information in the owner's manual can be found on the following pages of the owner's manual:
  - Smoke detector and CO monitor statement- page 2
  - Periodic inspection statement- page 2
- Statement regarding communication between lab and manufacturer were added to the Notes section on page 5.
- Conditioning data was verified to be over 50 hours. Data provided in supplemental data folder.

## Table of Contents

<b>Affidavit:</b> .....	<b>4</b>
<b>Introduction:</b> .....	<b>5</b>
<b>Notes:</b> .....	<b>5</b>
<b>Wood Heater Identification and Testing:</b> .....	<b>6</b>
<i>Test Procedures and Equipment:</i> .....	<b>7</b>
<b>Results:</b> .....	<b>8</b>
Emissions: .....	8
Efficiency: .....	10
<b>Summary Table:</b> .....	<b>12</b>
Run 1:.....	12
Run 2:.....	12
Run 3:.....	13
Run 4:.....	13
Run 5:.....	13
<b>Filter Catch:</b> .....	<b>14</b>
<i>Run 1:</i> .....	<b>14</b>
<i>Run 2:</i> .....	<b>14</b>
<i>Run 3:</i> .....	<b>15</b>
<i>Run 4:</i> .....	<b>15</b>
<i>Run 5 – Fan Confirmation:</i> .....	<b>16</b>
<i>Negative Filter Weights Discussion:</i> .....	<b>16</b>
<i>Train Precision:</i> .....	<b>17</b>
<i>Test Condition Summary:</i> .....	<b>17</b>
<b>Heater Specifications:</b> .....	<b>18</b>
<i>Useable firebox volume:</i> .....	<b>18</b>
<i>Air Flow Schematic</i> .....	<b>19</b>
<i>Process Operations and Description:</i> .....	<b>24</b>
<i>Settings &amp; Run Notes</i> .....	<b>24</b>
<i>Test Fuel Properties:</i> .....	<b>25</b>
<i>Sampling Locations and Descriptions:</i> .....	<b>26</b>
<i>Sample Points</i> .....	<b>26</b>
<b>Sampling Methods:</b> .....	<b>27</b>
<b>Analytical Methods Description:</b> .....	<b>27</b>

**Calibration, Quality Control and Assurances:..... 27**

**Appliance Sealing and Storage: ..... 27**

*Sealing Label* ..... 27

*Sealed Unit*..... 28

**Appendices:..... 29**

***Appendix A:* ..... 29**

        Sampling and Analytical Procedures ..... 29

***Appendix B:* ..... 29**

        Participants..... 29

        Analysis and Report Writing ..... 29

        Observers:..... 29

***Appendix C:* ..... 29**

        Appliance Updates ..... 29

***Appendix D:* ..... 30**

        Test Equipment Calibration Audit:..... 30

***Appendix E:* ..... 31**

        Accreditations:..... 31

***Raw Data:* ..... 35**



## Affidavit:

Dirigo Laboratories, Inc. was contracted by New Buck Corporation, Inc. to provide testing services for the Model 21NC – free standing wood fired heater per EPA Method 28R for Certification and Auditing of Wood Heaters. All testing and associated procedures were conducted at Dirigo Laboratories, Inc. beginning on 8/9/2016 and ending on 8/16/2016. Dirigo Laboratories is located at 11785 SE Highway 212 – Suite 305, Clackamas, Oregon 97015. Testing procedures followed EPA Method 28R and ASTM E2780-10. Particulate sampling was performed per ASTM E2515-10 *Standard Test Method for Determination of Particulate Matter Emissions Collected by a Dilution Tunnel*.

Dirigo Laboratories is accredited by the U.S. Environmental Protection Agency for the certification and auditing of wood heaters pursuant to subpart AAA of 40 CFR Part 60, New Source Performance Standards for Residential Wood Heaters and subpart QQQQ of 40 CFR Part 60, Standards of Performance for New Hydronic Heaters and Forced Air Furnaces, Methods 28R, 28WHH, 28 WHH-PTS, and all methods listed in Sections 60.534 and 60.5476. Dirigo holds EPA Accreditation Certificate Numbers 4 and 4M (mobile). Dirigo Laboratories, Inc. is accredited by A2LA to ISO 17020:2012 “Criteria for Bodies Performing Inspections, ISO 17025:2005 “Requirements for Testing Laboratories”, and ISO 17065:2012 “Requirements for Bodies Operating Product Certification Systems”. Dirigo holds A2LA Certificate Numbers 3726.01, 3726.02, and 3726.03. See Appendix E for Accreditations.

The following people were associated with the testing, analysis and report writing associated with this project.

**John  
Steinert**

Digitally signed by John Steinert  
DN: cn=John Steinert, o=Dirigo, ou,  
email=jsteinert@dirigolab.com,  
c=US  
Date: 2016.09.22 16:20:17 -07'00'

---

John Steinert, President

**Gary Nelke**

Digitally signed by Gary Nelke  
DN: cn=Gary Nelke, o, ou,  
email=gnelke@dirigolab.com,  
c=US  
Date: 2016.09.23 11:24:39 -07'00'

---

Gary Nelke, CMfgE

**Doug  
Towne**

Digitally signed by Doug Towne  
DN: cn=Doug Towne, o=Dirigo,  
ou=QA/QC,  
email=dtowne@dirigolab.com,  
c=US  
Date: 2016.09.22 11:46:50 -07'00'

---

Doug Towne, QA Manager

## Introduction:

New Buck Corporation, Inc. of Spruce Pine, NC, contracted with Dirigo Laboratories, Inc. to perform EPA certification testing on their Model 21NC free standing non-catalytic wood heater. All testing was performed at Dirigo Laboratories, Inc. Testing was performed by Mr. Gary Nelke CMfgE.

## Notes:

- A 50 hour break-in was performed on the appliance at Dirigo Laboratories, Inc. Data is provided in separate electronic folder.
- Prior to testing, the dilution tunnel was cleaned with a steel brush.
- Run #'s 1, 2, 3 & 4 were performed with the convection blower in operation. Run #5 was the blower confirmation run and was performed with the convection blower off.
- Front filters were changed on sample train A at one hour for all runs.
- Communication regarding stove operation was consistent with operating instructions as provided in the operations manual. No other documentation was provided.

## Wood Heater Identification and Testing:

- Appliance Tested: **Model 21NC**
- Serial Number: **012176**
- Manufacturer: **New Buck Corporation, Inc.**
- Catalyst: **No**
- Heat exchange blower: **Optional**
- Type: **Wood Stove**
- Style: **Free Standing**
- Date Received: **Thursday, May 19, 2016**
- Wood Heater Aging: **July 5-14, 2016**
- Testing Period – Start: **Tuesday, August 09, 2016**    Finish: **Tuesday, August 16, 2016**
- Test Location: **Dirigo Laboratories, Inc. 11785 SE HWY 212 - Suite 305, Clackamas, OR 97015**
- Elevation: **≈131 Feet above sea level**
- Test Technician(s): **Gary Nelke**
- Observers: **NA**

## Test Procedures and Equipment:

All Sampling and analytical procedures were performed by Gary Nelke. All procedures used were directly from EPA Method 28R, ASTM E2780-10 and ASTM E2515-10. Efficiency was calculated per CSA B415.1-10. See the list below for equipment used. See Appendix D for calibration data.

### Equipment List:

1. Analyzer -California Analytical ZRE CO<sub>2</sub>/CO/O<sub>2</sub> IR ANALYZER
2. Delmhorst J-2000 Wood Moisture Meter
3. Dayton 4c121 Blower for dilution tunnel -Emissions Booth #1
4. ScienTech Balance Scale
5. 10 lb Calibration Weight
6. DigiWeigh Bench Shipping Scale
7. APEX XC-60 Digital Emissions Sampling Box A
8. APEX XC-60 Digital Emissions Sampling Box B
9. APEX Ambient sampling box
10. Gast MOA-P122-AA Vacuum Pump
11. Rice Lake 3'x3' floor scale w/digital weight indicator

## Results:

The weighted average emission rate is **1.7 g/hr** with a weighted average efficiency of **70.5%**. The average CO emissions were **1.53 g/min**. The New Buck Corporation, Inc. Model 21NC non-catalytic wood stove meets the 2020 PM emission standard of  $\leq 2.0$  g/hr per CFR 40 part 60, §60.532 (b).

Detailed individual run data can be found in separate digital folders supplied with this report.

### Emissions:

EPA Method 28 - Weighted Average			
			
<b>Weighted Average: 1.7 (g/hr)</b>			
Client:	New Buck Corporation		
Model:	21NC		
Tracking No.:	48		
Project No.:	037-S-048-6 B		
Test Dates:	8/9/16 - 8/16/16		
Burn Rate Category	1	Burn Rate Category	2
Burn Rate (kg/hr-dry)	0.77	Burn Rate (kg/hr-dry)	0.99
Emissions Rate (g/hr)	1.0	Emissions Rate (g/hr)	1.9
Emissions Rate Cap (g/hr)	15	Emissions Rate Cap (g/hr)	15
Weighting Factor	21.24%	Weighting Factor	26.15%
Run Number	1	Run Number	2
Burn Rate Category	3	Burn Rate Category	4
Burn Rate (kg/hr-dry)	1.35	Burn Rate (kg/hr-dry)	2.24
Emissions Rate (g/hr)	1.7	Emissions Rate (g/hr)	2.3
Emissions Rate Cap (g/hr)	15	Emissions Rate Cap (g/hr)	18
Weighting Factor	32.73%	Weighting Factor	19.88%
Run Number	3	Run Number	4

### EPA Method 28 - Weighted Average



Client: New Buck Corporation  
Model: 21NC  
Tracking No.: 48  
Project No.: 037-S-048-6 B  
Test Dates: 8/9/16 - 8/16/16

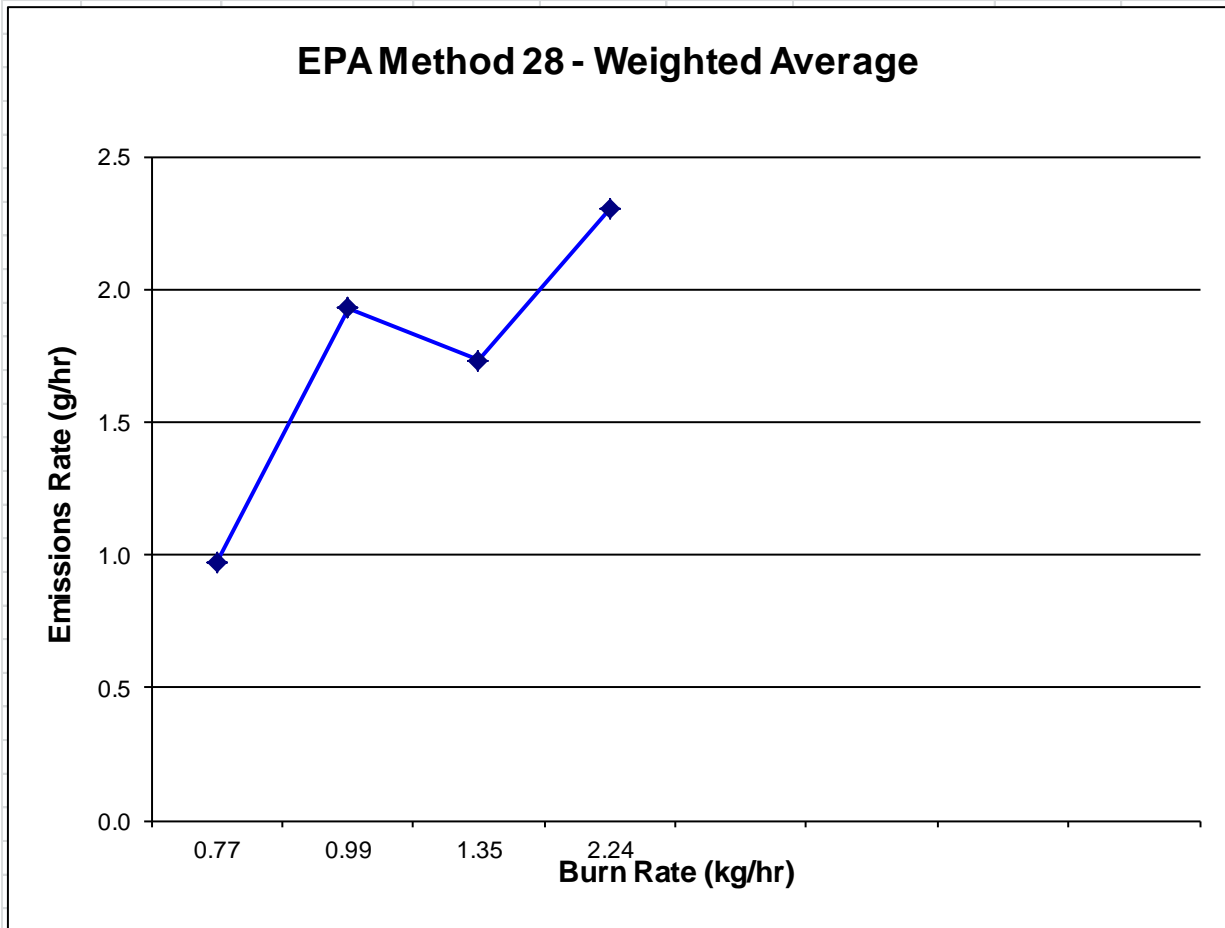

*Efficiency:*

All efficiency values use the HHV.

CSA B415.1-10 Weighted Average			
			
<b>Weighted Average: 70.5 %</b>			
Client:	New Buck Corporation		
Model:	21NC		
Tracking No.:	48		
Project No.:	037-S-048-6 B		
Test Dates:	8/9/16 - 8/16/16		
Burn Rate Category	1	Burn Rate Category	2
Burn Rate (kg/hr-dry)	0.77	Burn Rate (kg/hr-dry)	0.99
OA Efficiency %	72.9	OA Efficiency %	69.4
Emissions Rate Cap (g/hr)	15	Emissions Rate Cap (g/hr)	15
Weighting Factor	21.24%	Weighting Factor	26.15%
Run Number	1	Run Number	2
Burn Rate Category	3	Burn Rate Category	4
Burn Rate (kg/hr-dry)	1.35	Burn Rate (kg/hr-dry)	2.24
OA Efficiency %	73.1	OA Efficiency %	65.2
Emissions Rate Cap (g/hr)	15	Emissions Rate Cap (g/hr)	18
Weighting Factor	32.73%	Weighting Factor	19.88%
Run Number	3	Run Number	4

### CSA B415.1-10 - Weighted Average



Client: New Buck Corporation  
Model: 21NC  
Tracking No.: 48  
Project No.: 037-S-048-6 B  
Test Dates: 8/9/16 - 8/16/16

### EPA Method 28 - Weighted Average

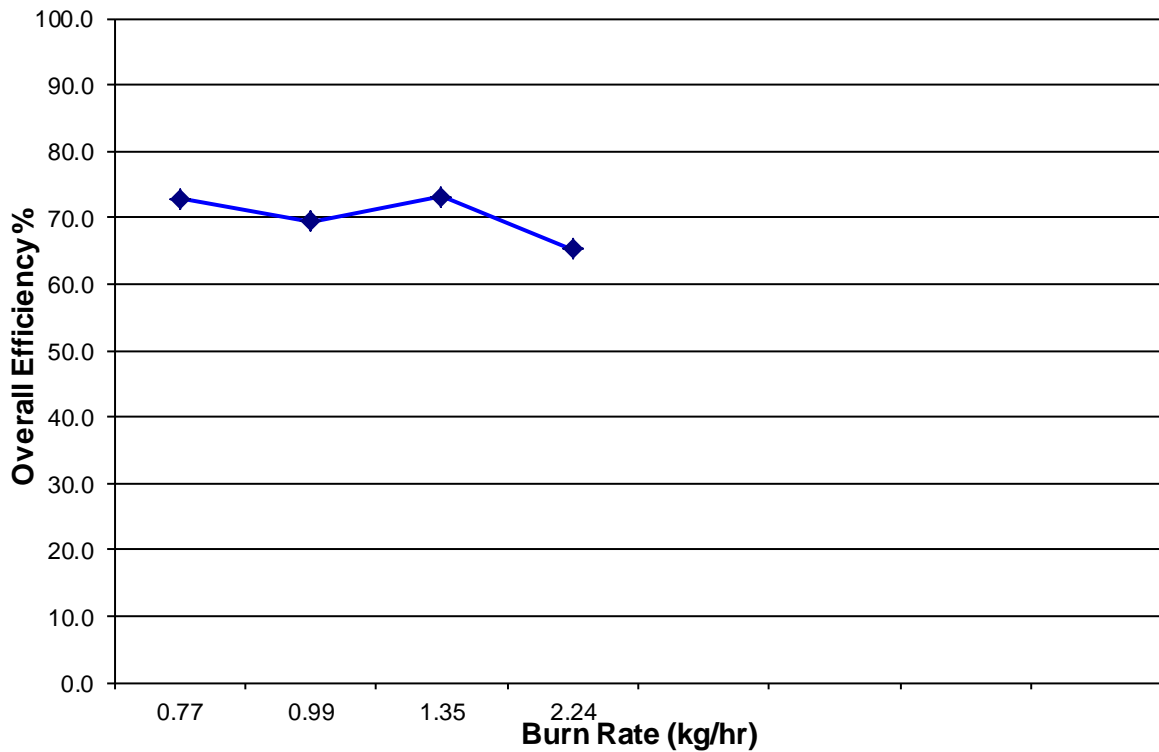



## Summary Table:

Category 1 < 0.80 kg/hr		Category 2 0.80 to 1.25 kg/hr		Category 3 1.25 to 1.90 kg/hr		Category 4 Maximum	
Run Number 1		Run Number 2		Run Number 3		Run Number 4	
Emissions Rate g/hr	0.97	Emissions Rate g/hr	1.93	Emissions Rate g/hr	1.73	Emissions Rate g/hr	2.30
Burn Rate kg/hr	0.77	Burn Rate kg/hr	0.99	Burn Rate kg/hr	1.35	Burn Rate kg/hr	2.24
BTU/hr (HHV)	11,079	BTU/hr (HHV)	13,648	BTU/hr (HHV)	19,504	BTU/hr (HHV)	28,901
CO g/min	1.40	CO g/min	2.0	CO g/min	1.56	CO g/min	1.16
OA Efficiency (HHV)	72.9%	OA Efficiency (HHV)	69.4%	OA Efficiency (HHV)	73.1%	OA Efficiency (HHV)	65.2%
1 hour filter- g/hr	1.9	1 hour filter- g/hr	3.25	1 hour filter- g/hr	2.05	1 hour filter- g/hr	1.84

### *Run 1:*

Run 1 was a category I burn rate performed on 8/09/16. The test duration was 4 hours 30 minutes. The fuel weight was 9.2 lbs. There was an average particulate emissions rate of 0.97 g/hr. The run had an overall efficiency of 72.9%. CO emissions were 1.4 g/min. The A filter was changed at 1 hr. The 1-hour filter catch was 1.9 g/hr. All test results were appropriate and valid. The burn rate category was achieved. There were no anomalies and all criteria were met.

### *Run 2:*

Run 2 was a category II burn rate performed on 8/10/16. The test duration was 3 hours 40 minutes. The fuel weight was 9.6 lbs. There was an average particulate emissions rate of 1.93 g/hr. The run had an overall efficiency of 69.4%. CO emissions were 2.0 g/min. The A filter was changed at 1 hr. The 1-hour filter catch was 3.25 g/hr. All test results were appropriate and valid. The burn rate category was achieved. There were no anomalies and all criteria were met.

### *Run 3:*

Run 3 was a category III burn rate performed on 8/11/16. The test duration was 2 hours 30 minutes. The fuel weight was 9.0 lbs. There was an average particulate emissions rate of 1.73 g/hr. The run had an overall efficiency of 73.1%. CO emissions were 1.56 g/min. The A filter was changed at 1 hr. The 1-hour filter catch was 2.05 g/hr. All test results were appropriate and valid. The burn rate category was achieved. There were no anomalies and all criteria were met.

### *Run 4:*

Run 4 was a category IV burn rate performed on 8/12/16. The test duration was 1 hour 30 minutes. The fuel weight was 8.9 lbs. There was an average particulate emissions rate of 2.3 g/hr. The run had an overall efficiency of 65.2%. CO emissions were 1.16 g/min. The A filter was changed at 1 hr. The 1-hour filter catch was 1.84 g/hr. All test results were appropriate and valid. The burn rate category was achieved. There were no anomalies and all criteria were met.

### *Run 5:*

Run 5 was the fan confirmation run performed on 8/16/16. The test duration was 3 hours 30 minutes. The fuel weight was 9.2 lbs. There was an average particulate emissions rate of 2.52 g/hr. CO emissions were 2.03 g/min. Per Method 28 & ASTM E2515-10 a category II run was performed with the fan in the off position. The emission rate resulting from this test run without the blower operating is equal to or less than the emissions rate plus 1.0 g/h for the test run in the medium burn rate category with the blower operating. Because of this, the wood heater is considered to have the same average emissions rate with or without the blower operating. Additional test runs without the blower operating are unnecessary.

### Filter Catch:

#### Run 1:

Project #	037-S-048-6B		MFG	New Buck Corporation	
Run #	1		Model	21NC	
Date	8/16/16				

Train A	Front	Rear	Filter #	Tare	Final	Net
First Hour	<input checked="" type="checkbox"/>		2854	0.1182	0.1217	0.0035
	<input type="checkbox"/>	<input checked="" type="checkbox"/>	2855			
	<input checked="" type="checkbox"/>	<input type="checkbox"/>	2859	0.2392	0.2398	
	<input checked="" type="checkbox"/>	<input type="checkbox"/>	O Ring			0.0008
	<input type="checkbox"/>	<input checked="" type="checkbox"/>	O Ring	3.5530	3.5532	
						4.3 mg

Train B	Front	Rear	Filter #	Tare	Final	Net
	<input checked="" type="checkbox"/>	<input type="checkbox"/>	2856			
	<input type="checkbox"/>	<input checked="" type="checkbox"/>	2857	0.2409	0.2441	
	<input checked="" type="checkbox"/>	<input type="checkbox"/>	O ring			0.0038
	<input type="checkbox"/>	<input checked="" type="checkbox"/>	O ring	3.5686	3.5692	
						3.8 mg

Nozzle	#	TARE	FINAL	Net
2A	116.2328	116.2319	-0.0009	0.0

Nozzle	#	TARE	FINAL	Net
2B	116.3260	116.3260	0.0	0.0

<b>Train A Total Catch</b>	<b>4.3</b>
<b>Train B Total Catch</b>	<b>3.8</b>

Ambient	Filter #	Tare	Final	Net	Vol (liter)
<input checked="" type="checkbox"/>	2858	0.1182	0.1185	0.0003	1509.6
	O ring	1.6485	1.6486	0.0	
	Total				0.0003 mg

Notes: Train A Total: 4.3mg    Train B Total: 3.8mg    Ambient Total: 0.3mg    1 Hour Catch: 3.5mg

#### Run 2:

Project #	037-S-048-6B		MFG	New Buck Corporation	
Run #	2		Model	21NC	
Date	8/17/16				

Train A	Front	Rear	Filter #	Tare	Final	Net
First Hour	<input checked="" type="checkbox"/>		2860	0.1166	0.1226	0.0060
	<input type="checkbox"/>	<input checked="" type="checkbox"/>	2861			
	<input checked="" type="checkbox"/>	<input type="checkbox"/>	2865	0.2357	0.2361	
	<input checked="" type="checkbox"/>	<input type="checkbox"/>	O Ring			0.0005
	<input type="checkbox"/>	<input checked="" type="checkbox"/>	O Ring	3.5893	3.5894	
						6.5 mg

Train B	Front	Rear	Filter #	Tare	Final	Net
	<input checked="" type="checkbox"/>	<input type="checkbox"/>	2862			
	<input type="checkbox"/>	<input checked="" type="checkbox"/>	2863	0.2375	0.2438	
	<input checked="" type="checkbox"/>	<input type="checkbox"/>	O ring			0.0067
	<input type="checkbox"/>	<input checked="" type="checkbox"/>	O ring	3.5535	3.5539	
						6.7 mg

Nozzle	#	TARE	FINAL	Net
3A	116.0687	116.0687	0.0	0.0

Nozzle	#	TARE	FINAL	Net
3B	116.3360	116.3360	0.0	0.0

<b>Train A Total Catch</b>	<b>6.5</b>
<b>Train B Total Catch</b>	<b>6.7</b>

Ambient	Filter #	Tare	Final	Net	Vol (liter)
<input checked="" type="checkbox"/>	2864	0.1206	0.1208	0.0002	1235.09
	O ring	1.6936	1.6938	0.0002	
	Total				0.0004 mg

Notes: Train A Total: 6.5mg    Train B Total: 6.7mg    Ambient Total: 0.4mg    1 Hour Catch: 6.0mg

Run 3:

Project #	037-S-048-6B		MFG	New Buck Corporation	
Run #	3		Model	21NC	
Date	8/17/16				

Train A	Front	Rear	Filter #	Tare	Final	Net
First Hour	<input checked="" type="checkbox"/>		2866	0.1181	0.1218	0.0037
	<input type="checkbox"/>	<input checked="" type="checkbox"/>	2867			
	<input checked="" type="checkbox"/>	<input type="checkbox"/>	2871	0.2394	0.2400	
	<input checked="" type="checkbox"/>	<input type="checkbox"/>	O Ring			
	<input type="checkbox"/>	<input checked="" type="checkbox"/>	O Ring	3.5920	3.5920	0.0006
						4.3 mg

Train B	Front	Rear	Filter #	Tare	Final	Net
	<input checked="" type="checkbox"/>	<input type="checkbox"/>	2868			
	<input type="checkbox"/>	<input checked="" type="checkbox"/>	2869	0.2369	0.2402	
	<input checked="" type="checkbox"/>	<input type="checkbox"/>	O ring			
	<input type="checkbox"/>	<input checked="" type="checkbox"/>	O ring	3.5294	3.5295	0.0034
						3.4 mg

Nozzle	#	TARE	FINAL	Net
4A	116.1803	116.1802	-0.0001	0

Nozzle	#	TARE	FINAL	Net
4B	116.3939	116.3939	0.0	0.0

<b>Train A Total Catch</b>	4.3
<b>Train B Total Catch</b>	3.4

Ambient	Filter #	Tare	Final	Net	Vol (liter)
<input checked="" type="checkbox"/>	2870	0.1217	0.1216	-0.0001	843.53
	O ring	1.6647	1.6645	-0.0002	
	Total				-0.0003 mg

Notes: Train A Total: 4.3mg    Train B Total: 3.4mg    Ambient Total: 0.0mg    1 Hour Catch: 3.7mg

Negative ambient filter weight and prob recorded- see discussion below.

Run 4:

Project #	037-S-048-6B		MFG	New Buck Corporation	
Run #	4		Model	21NC	
Date	8/17/16				

Train A	Front	Rear	Filter #	Tare	Final	Net
First Hour	<input checked="" type="checkbox"/>		2872	0.1180	0.1215	0.0035
	<input type="checkbox"/>	<input checked="" type="checkbox"/>	2873			
	<input checked="" type="checkbox"/>	<input type="checkbox"/>	2877	0.2369	0.2371	
	<input checked="" type="checkbox"/>	<input type="checkbox"/>	O Ring			
	<input type="checkbox"/>	<input checked="" type="checkbox"/>	O Ring	3.5835	3.5831	0.0002
						3.7 mg

Train B	Front	Rear	Filter #	Tare	Final	Net
	<input checked="" type="checkbox"/>	<input type="checkbox"/>	2874			
	<input type="checkbox"/>	<input checked="" type="checkbox"/>	2875	0.2389	0.2417	
	<input checked="" type="checkbox"/>	<input type="checkbox"/>	O ring			
	<input type="checkbox"/>	<input checked="" type="checkbox"/>	O ring	3.5691	3.5692	0.0029
						2.9 mg

Nozzle	#	TARE	FINAL	Net
5A	116.7701	116.7701	0.0	0.0

Nozzle	#	TARE	FINAL	Net
5B	116.8783	116.8783	0.0	0.0

<b>Train A Total Catch</b>	3.7
<b>Train B Total Catch</b>	2.9

Ambient	Filter #	Tare	Final	Net	Vol (liter)
<input checked="" type="checkbox"/>	2876	0.1217	0.1219	0.0002	501.49
	O ring	1.6697	1.6696	0.0	
	Total				0.0002 mg

Notes: Train A Total: 3.7mg    Train B Total: 2.9mg    Ambient Total: 0.2mg    1 Hour Catch: 3.5mg

### Run 5 – Fan Confirmation:

Project #	037-S-048-6B		MFG	New Buck Corporation										
Run #	5		Model	21										
Date	8/19/16													
<b>Train A</b>	Front	Rear	Filter #	Tare	Final	Net	<b>Train B</b>	Front	Rear	Filter #	Tare	Final	Net	
<b>First Hour</b>	<input checked="" type="checkbox"/>		2878	0.1195	0.1271	0.0076		<input checked="" type="checkbox"/>	<input type="checkbox"/>	2880				
	<input type="checkbox"/>	<input checked="" type="checkbox"/>	2879					<input type="checkbox"/>	<input checked="" type="checkbox"/>	2881	0.2412	0.2482		
	<input checked="" type="checkbox"/>	<input type="checkbox"/>	2883	0.2429	0.2433			<input checked="" type="checkbox"/>	<input type="checkbox"/>	O ring			0.0076	
	<input checked="" type="checkbox"/>	<input type="checkbox"/>	O Ring					<input type="checkbox"/>	<input checked="" type="checkbox"/>	O ring	3.5970	3.5976		
	<input type="checkbox"/>	<input checked="" type="checkbox"/>	O Ring	3.5454	3.5463	0.0013								
						8.9	mg						7.6	mg
Nozzle	#	TARE	FINAL	Net				Nozzle	#	TARE	FINAL	Net		
	6A	116.5635	116.5635	0.0	0.0				6B	116.1181	116.1181	0.0	0.0	
	<b>Train A Total Catch</b>					8.9		<b>Train B Total Catch</b>					7.6	
<b>Ambient</b> <input checked="" type="checkbox"/>	Filter #	Tare	Final	Net	Vol (liter)									
	2882	0.1177	0.1177	0.0	1168.995									
	O ring	1.6924	1.6927	0.0003										
	Total			0.0003	mg									
Notes:	Train A Total: 8.9mg		Train B Total: 7.6mg		Ambient Total: 0.3mg		1 Hour Catch: 7.6mg							

### Negative Filter Weights Discussion:

Upon completion of testing, lab analysis of the sample filter for the Ambient Train for Run #3 yielded a negative number (-0.1 mg). Per ASTM E2515 Sec 10.2.2.1 any negative ambient filter weights should be reported as 0. The negative values report during this run should be considered valid and appropriately handled.

Per ASTM E2515 Sec. 10.2.3 the negative probe weight (-0.1 mg) recorded is  $\leq 5\%$  of the total catch and considered valid.

## Train Precision:

<b>Dual Train Comparison (ASTM E2515 11.7 - If <u>either</u> criterion (7.5% of average or 0.5 g/kg difference) is met, the run is valid.</b>									
Run #	Train A % of avg.	Train B % of avg.	Max difference	<7.5% of average?	Or	Train A g/kg	Train B g/kg	Difference	<0.5 g/kg from each other?
1	106.7	93.3	6.7	✓		1.355	1.184	0.171	✓
2	97.8	102.2	2.2	✓		1.897	1.985	0.088	✓
3	110.8	89.2	10.8	X		1.427	1.148	0.279	✓
4	112.1	87.9	12.1	X		1.154	0.905	0.249	✓
5	107.4	92.6	7.4	✓		2.712	2.336	0.376	✓

## Test Condition Summary:

All testing conditions for all runs fell within allowable specifications of EPA Method 28R, ASTM E2780-10 and ASTM E2515-10. A summary of facility conditions, temperature averages, fuel burned and run times is listed below.

Runs	Ambient (Deg. F)		Barometric Pressure (In. Hg.)	Test Fuel Burned (Lbs.)	Test Fuel Moisture (Dry Basis)	Run Time (Min.)
	Pre	Post				
1	71	77	30.03	9.2	20.9	270
2	75	78	30.04	9.6	19.7	220
3	72	74	30.04	9.0	21.3	150
4	75	78	29.99	8.9	20.4	90

# Heater Specifications:

Dimensions, firebox configuration, air supply locations, air introduction locations, and baffle locations of the wood heater are referenced below and on the following page.

Useable firebox volume:

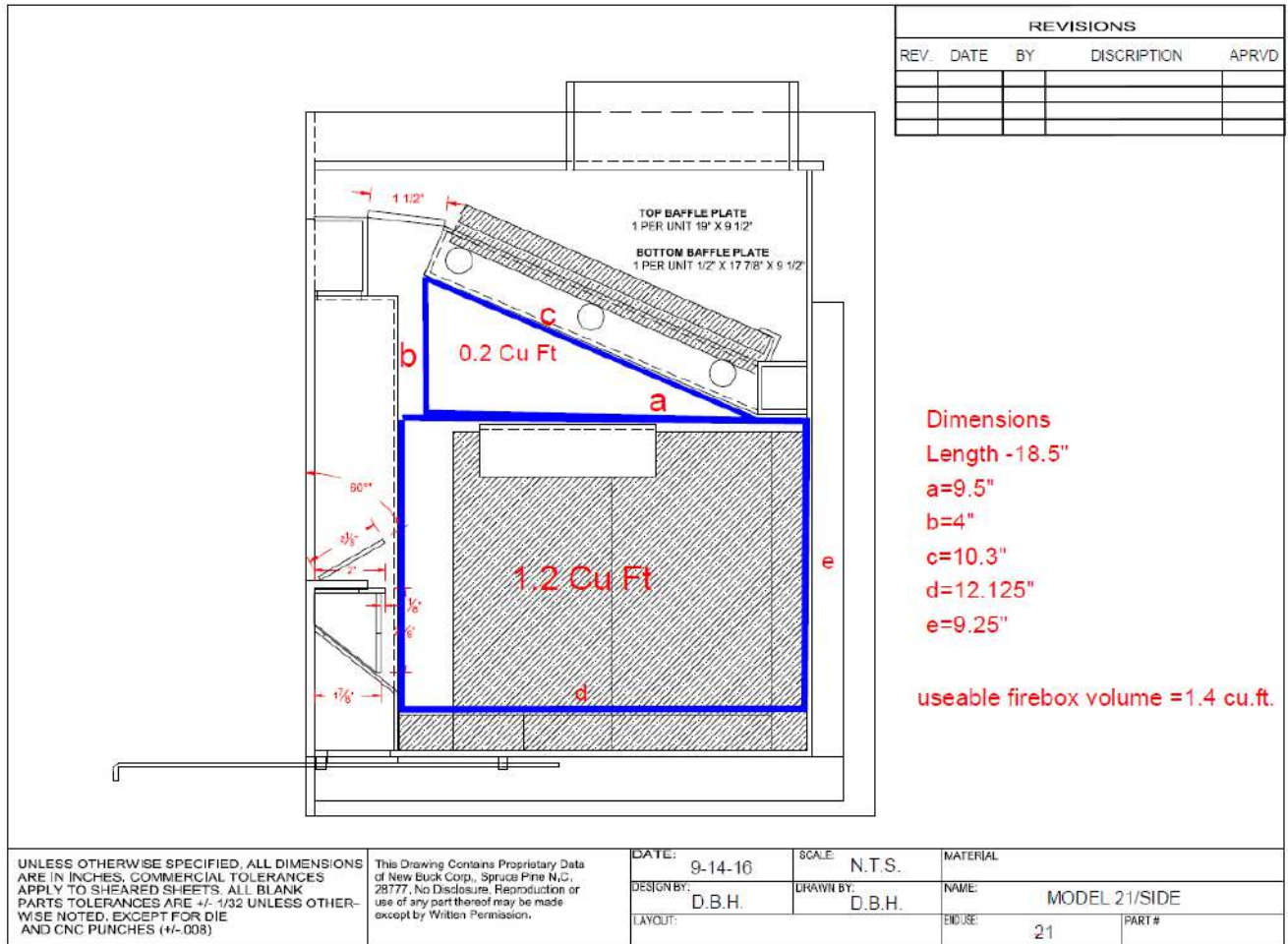

Useable firebox volume = 1.4 Cu. Ft.

# Air Flow Schematic

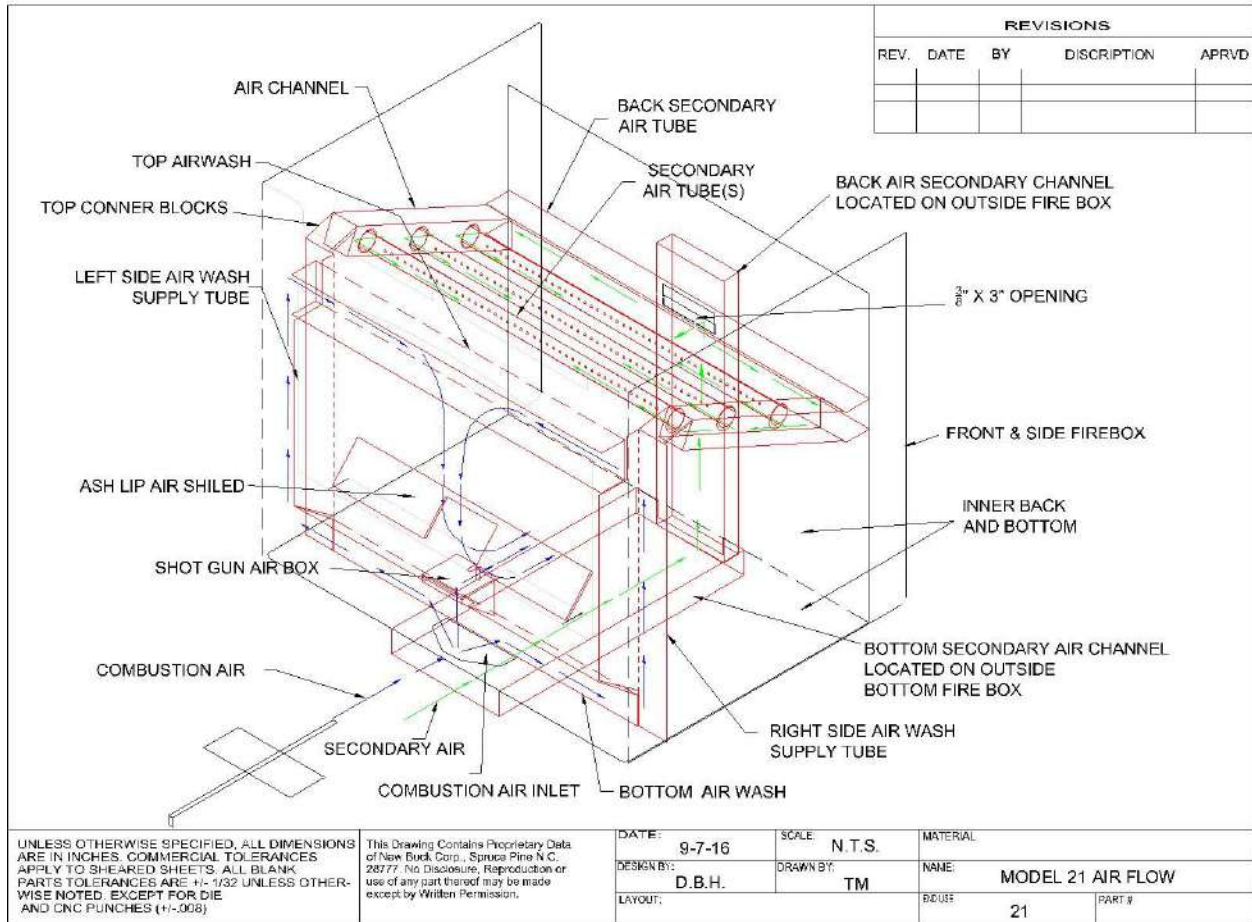



Front



Left



Right



Rear



## Process Operations and Description:

The appliance was operated according to procedures as described in the Operations Manual. Detailed run information can be found in corresponding digital folders submitted with this report.

## Settings & Run Notes

	Run Notes	
	Pre-Burn	Test Run
<b>Run 1</b>	Primary set to 2 1/8". Start at 0840	Category I. Test start: 0952 - Door open 40 seconds, Primary fully open. At 5 mins Primary air set to 2 1/8", fan off. Fan set to low at 1012. Front Filter change at 1052. END test: 1422 – Run time 4.5 hr.
<b>Run 2</b>	Primary set to 2 1/16". Start at 0820	Category II: Test start: 0930 –Door open 30 seconds, Primary fully open. At 5 mins Primary set to 2 1/16", fan off. Fan set to low at 0950. Front filter change at 1030. END Test: 1310 - Run time 3 hr 40 mins.
<b>Run 3</b>	Primary Set to 2". Start at 0840	Category III: Test start: 1002 - Door open 40 seconds, Primary fully open. At 5 mins Primary set to 2", fan off. Fan set to med/high at 1022. Front filter changed at 1102. END test: 1232 - Run time 2.5 hr.
<b>Run 4</b>	Primary fully open. Start at 0830	Category IV: Test start: 0940. Door Open 30 seconds. Primary air fully open. Front filter Change at 1040. Run Time: 1.5 hr.
<b>Run 5</b>	Primary Set to 2 1/8". Start at 1355	Fan Confirmation - Fan OFF. Category II: Test start: 1507. Door open 30 seconds, Primary fully open. At 5 mins Primary air set to 2 1/8", fan off. Change front filter at 1607. END test: 1837 - Run time: 3.5 hr.

## Test Fuel Properties:



Fuel consisted of 2"x4"x16" Green, Douglas fir. Detailed fuel load specifications for each run can be found in the corresponding digital folders submitted with this report.



## Sampling Locations and Descriptions:

**Sample ports are located 16.5 feet downstream from any disturbances and 1 foot upstream from any disturbances.** Flow rate traverse data was collected 12 feet downstream from any disturbances and 5.5 feet upstream from any disturbances. (See below)

## Sample Points

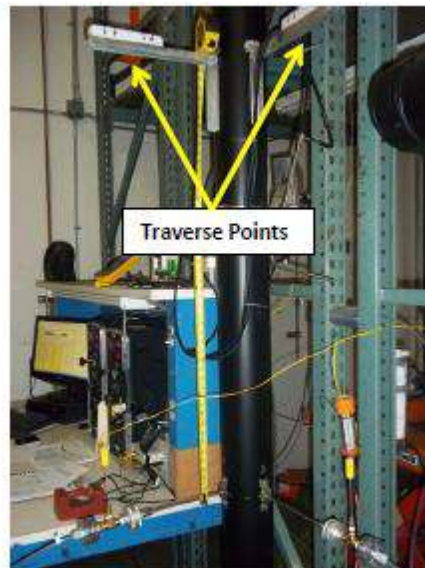
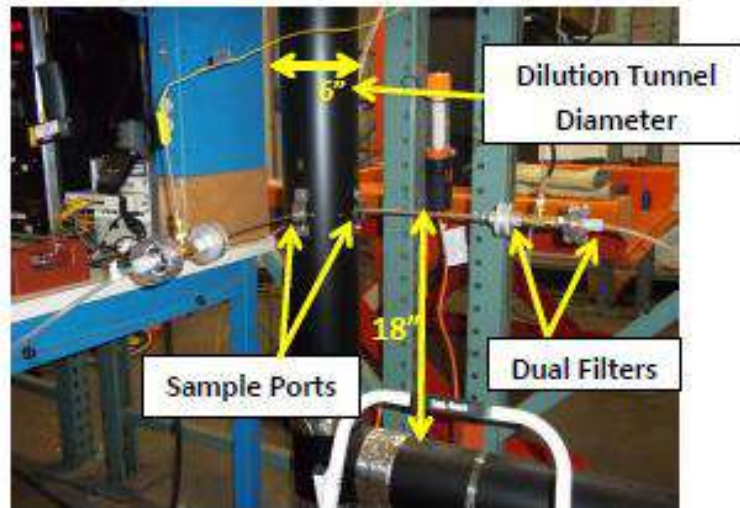

## Sampling Methods:

EPA ASTM E2515-11 was used in collecting particulate samples. The dilution tunnel is 6 inches in diameter. All sampling conditions per ASTM E2515-11 were followed. No alternate procedures were used.

## Analytical Methods Description:

All sample recovery and analysis procedures followed EPA ASTM E2515-11 procedures. At the end of each test run, filters and probes were removed from their housings, dessicated for 24 hours, and then weighed at 6 hour intervals to a constant weight per ASTM E2515-11 section 11.0.

## Calibration, Quality Control and Assurances:

Calibration procedures and results were conducted per EPA Method 28R, ASTM E2515-11 and ASTM E2780-10. Test method quality control procedures (leak checks, volume meter checks, stratification checks, proportionality results) followed the procedures outlined.

## Appliance Sealing and Storage:

Following securing with metal strapping and the seal below, the appliance was placed into storage at client facilities located at: 200 Ethan Allen Dr., Spruce Pine, NC 28777.

### Sealing Label

<b>ATTENTION:</b>	
<b>THIS SEAL IS NOT TO BE BROKEN WITHOUT PRIOR AUTHORIZATION FROM THE UNITED STATES ENVIRONMENTAL PROTECTION AGENCY.</b>	
<b>THIS APPLIANCE HAS BEEN SEALED IN ACCORDANCE WITH REQUIREMENTS OF 40 CFR PART 60 SUBPART AAA §60.535(g)</b>	
REPORT # _____	DATE SEALED _____
MANUFACTURER _____	MODEL # _____



## Sealed Unit



## Appendices:

### Appendix A:

#### *Sampling and Analytical Procedures*

All Sampling and analytical procedures were performed by Gary Nelke and Ben Nelke. All procedures used were directly from EPA Method 28R, ASTM 2515-11 and ASTM E2780-10. No alternative procedures were used for this test series.

### Appendix B:

#### *Participants*

The following personnel performed all testing:

- Gary Nelke CMfgE

#### *Analysis and Report Writing*

The following people were involved with analysis and report writing:

- Ben Nelke, Gary Nelke CMfgE, Doug Towne

#### *Observers:*

The following people were observers during testing:

- NA

### Appendix C:

#### *Appliance Updates*

No updates to the appliance were made.

## Appendix D:

### *Test Equipment Calibration Audit:*

- Calibrations for the platform scale and bench scale were performed with Certified Class F weights
- Moisture meter calibration was performed with Delmhorst moisture meter calibrator
- Gas Analyzer calibration performed with certified EPA Protocol gases
- 47mm filters weighed to a constant weight with calibrated analytical balance

All equipment calibration data submitted in separate digital file along with this report.

Appendix E:

*Accreditations:*

# CERTIFICATE OF ACCREDITATION

This certifies that:



Dirigo Laboratories, Inc.

**Has satisfied the requirements for laboratory accreditation for the certification of wood heaters pursuant to subpart AAA of 40 CFR Part 60, New Source Performance Standards For Residential Wood Heaters and subpart QQQQ of 40 CFR Part 60, Standards of Performance for New Hydronic Heaters and Forced Air Furnaces.**

October 21, 2015 - October 21, 2020  
EFFECTIVE DATE

  
MEASUREMENT TECHNOLOGY GROUP  
GROUP LEADER

Methods 28R, 28 WHH, 28 WHH-P1S,  
All Methods listed in Sections 60.534 and 60.5476  
METHODS

4  
CERTIFICATE NUMBER



American Association for Laboratory Accreditation

## Accredited Inspection Body

A2LA has accredited

**DIRIGO LABORATORIES, INC.**

*Clackamas, OR*

for technical competence as an

**Inspection Body**

This inspection body is accredited in accordance with the recognized International Standard ISO/IEC 17020:2012 *Conformity Assessment – Requirements for the operation of various types of bodies performing inspection*. This accreditation demonstrates technical competence for a defined scope and the operation of a quality management system.

Presented this 17<sup>th</sup> day of October 2014.



President & CEO  
For the Accreditation Council  
Certificate Number 3726.03  
Valid to December 31, 2016

*For the inspections to which this accreditation applies, please refer to the organization's Inspection Body Scope of Accreditation.*



American Association for Laboratory Accreditation

# Accredited Laboratory

A2LA has accredited

## DIRIGO LABORATORIES, INC.

Clakamas, OR

for technical competence in the field of

### Mechanical Testing

This laboratory is accredited in accordance with the recognized International Standard ISO/IEC 17025:2005 *General requirements for the competence of testing and calibration laboratories*. This accreditation demonstrates technical competence for a defined scope and the operation of a laboratory quality management system (refer to joint ISO-ILAC-IAF Communiqué dated 8 January 2009).

Presented this 17<sup>th</sup> day of October 2014.

President & CEO  
For the Accreditation Council  
Certificate Number 3726.01  
Valid to December 31, 2016



*For the tests or types of tests to which this accreditation applies, please refer to the laboratory's Mechanical Scope of Accreditation.*



American Association for Laboratory Accreditation

# Accredited Product Certification Body

A2LA has accredited

## DIRIGO LABORATORIES, INC.

Clackamas, OR  
for technical competence as a

### Product Certification Body

This product certification body is accredited in accordance with the recognized International Standard ISO/IEC 17065:2012 *Conformity Assessment – Requirements for Bodies Certifying Products, Processes and Services*. This accreditation demonstrates technical competence for a defined scope and the operation of a quality management system.

Presented this 17<sup>th</sup> day of October 2014.



President & CEO  
For the Accreditation Council  
Certificate Number 3726.02  
Valid to December 31, 2016

*For the product certification schemes to which this accreditation applies, please refer to the organization's Product Certification Scope of Accreditation.*

Raw Data:



Client BUCK 21  
Model 21NC  
Run # AGE#1

Total time = 50 hr 10 min

Project #  
Tracking #

Date 7\_5\_16 8 hours

Notes: Fuel moisture for all pieces 18-25%

Time	FLUE	SCALE	CH 3
12:33:12 PM	491		5
12:43:12 PM	313		4
12:53:12 PM	370		3
1:03:12 PM	406		4
1:13:12 PM	404		7 Added 5 lbs
1:23:12 PM	491		6
1:33:12 PM	421		4
1:43:12 PM	322		3
1:53:12 PM	244		3
2:03:12 PM	221		3
2:13:12 PM	201		2
2:23:12 PM	193		2
2:33:12 PM	348		9 added 7 lbs
2:43:12 PM	235		9
2:53:12 PM	210		9
3:03:12 PM	215		8
3:13:12 PM	377		7
3:23:12 PM	255		7
3:33:12 PM	259		6
3:43:12 PM	320		5
3:53:12 PM	347		5
4:03:12 PM	345		4
4:13:12 PM	339		4
4:23:12 PM	358		3
4:33:12 PM	329		3
4:43:12 PM	289		2
4:53:12 PM	249		2
5:03:12 PM	238		2
5:13:12 PM	292		9 added 7 lbs
5:23:12 PM	384		8
5:33:12 PM	417		7
5:43:12 PM	394		6
5:53:12 PM	378		6
6:03:12 PM	366		6
6:13:12 PM	353		5
6:23:12 PM	340		4
6:33:12 PM	332		4
6:43:12 PM	321		3
6:53:12 PM	320		3

7:03:12 PM	327	3
7:13:12 PM	294	2
7:23:12 PM	349	8 added 5 lbs
7:33:12 PM	411	7
7:43:12 PM	396	6
7:53:12 PM	397	5
8:03:12 PM	382	5
8:13:12 PM	365	4
8:23:12 PM	345	4
8:33:12 PM	330	3

Client BUCK 21

Model

Run # AGE#2

Project #

Tracking #

Date 7\_6\_16 8 hours

Notes: All fuel between 18-25%

Time	FLUE	SCALE	CH 3	CH 4
12:15:31 PM	530		8	Added 10 lbs
12:25:31 PM	434		7	
12:35:31 PM	418		6	
12:45:31 PM	428		5	
12:55:31 PM	440		4	
1:05:31 PM	423		2	
1:15:31 PM	373		2	
1:25:31 PM	302		2	
1:35:31 PM	381		8	Added 5 lbs
1:45:31 PM	366		7	
1:55:31 PM	386		7	
2:05:31 PM	380		6	
2:15:31 PM	371		5	
2:25:31 PM	347		5	
2:35:31 PM	327		4	
2:45:31 PM	368		4	
2:55:31 PM	412		3	
3:05:31 PM	402		3	
3:15:31 PM	401		2	
3:25:31 PM	360		2	
3:35:31 PM	315		1	
3:45:31 PM	434		8	added 7 lbs
3:55:31 PM	389		6	
4:05:31 PM	368		6	
4:15:31 PM	363		5	
4:25:31 PM	351		4	
4:35:31 PM	339		4	
4:45:31 PM	331		3	
4:55:31 PM	333		3	
5:05:31 PM	366		2	
5:15:31 PM	278		2	
5:25:31 PM	248		2	
5:35:31 PM	238		8	added 6 lbs
5:45:31 PM	267		7	
5:55:31 PM	323		7	
6:05:31 PM	307		6	
6:15:31 PM	338		5	
6:25:31 PM	299		5	
6:35:31 PM	295		4	

6:45:31 PM	417	4
6:55:31 PM	292	4
7:05:31 PM	363	6 Added 3 lbs
7:15:31 PM	354	6
7:25:31 PM	384	5
7:35:31 PM	386	4
7:45:31 PM	334	4
7:55:31 PM	263	3
8:05:31 PM	236	3
8:15:31 PM	228	3

Client BUCK 21

Model

Run # AGE#3

Project #

Tracking #

Date 7\_7\_16 7 hours 40 min

Notes: All fuel between 18-25%

Time	FLUE	SCALE	CH 3
11:59:21 AM	194		4 10 lbs
12:09:21 PM	485		3
12:19:21 PM	501		1
12:29:21 PM	491		4 added 5 lbs
12:39:21 PM	463		3
12:49:21 PM	443		2
12:59:21 PM	404		1
1:09:21 PM	385		1
1:19:21 PM	553		8 7 lbs
1:29:21 PM	530		6
1:39:21 PM	326		5
1:49:21 PM	247		5
1:59:21 PM	221		5
2:09:21 PM	211		5
2:19:21 PM	194		4
2:29:21 PM	184		4
2:39:21 PM	178		3
2:49:21 PM	297		3
2:59:21 PM	357		2
3:09:21 PM	455		6 7 lbs
3:19:21 PM	410		5
3:29:21 PM	341		4
3:39:21 PM	308		4
3:49:21 PM	288		4
3:59:21 PM	271		3
4:09:21 PM	354		7 5 lbs
4:19:21 PM	369		6
4:29:21 PM	353		6
4:39:21 PM	386		5
4:49:21 PM	360		5
4:59:21 PM	324		4
5:09:21 PM	323		4
5:19:21 PM	339		4
5:29:21 PM	332		3
5:39:21 PM	325		11 8 lbs
5:49:21 PM	415		10
5:59:21 PM	435		9
6:09:21 PM	430		8
6:19:21 PM	422		7

6:29:21 PM	424	6
6:39:21 PM	418	6
6:49:21 PM	412	5
6:59:21 PM	421	4
7:09:21 PM	377	4
7:19:21 PM	321	4
7:29:21 PM	295	3
7:39:21 PM	283	3

Client BUCK 21  
Model  
Run # AGE#4  
Project #  
Tracking #  
Date 7\_8\_16 3 hours 30 min

Notes: All fuel 18-25%

Time	FLUE	SCALE	CH 3
12:00:47 PM	173		6 6 lbs
12:10:47 PM	873		3
12:20:47 PM	300		2
12:30:47 PM	506		8 5 lbs
12:40:47 PM	539		7
12:50:47 PM	442		6
1:00:47 PM	424		5
1:10:47 PM	390		4
1:20:47 PM	341		3
1:30:47 PM	316		3
1:40:47 PM	295		3
1:50:47 PM	239		3
2:00:47 PM	214		2
2:10:47 PM	200		6 4 lbs
2:20:47 PM	633		5
2:30:47 PM	565		4
2:40:47 PM	536		3
2:50:47 PM	387		3
3:00:47 PM	376		2
3:10:47 PM	459		5 3 lbs
3:20:47 PM	430		5
3:30:47 PM	413		4

Client BUCK  
Model 21  
Run # AGE#5  
Project # BUCK21  
Tracking #  
Date 7\_12\_16 7 hour 30 min

Notes: All fuel 18-25%

Time	FLUE	SCALE
12:25:32 PM	150	3
12:25:42 PM	154	3
12:25:52 PM	167	3
12:26:02 PM	179	3
12:26:12 PM	189	3
12:26:22 PM	198	3
12:26:32 PM	206	3
12:26:42 PM	216	3
12:26:52 PM	225	3
12:27:02 PM	234	3
12:27:12 PM	244	3
12:27:22 PM	254	3
12:27:32 PM	262	3
12:27:42 PM	269	3
12:27:52 PM	275	3
12:28:02 PM	280	2
12:28:12 PM	284	3
12:28:22 PM	289	3
12:28:32 PM	294	3
12:28:42 PM	299	2
12:28:52 PM	305	3
12:29:02 PM	314	3
12:29:12 PM	322	3
12:29:22 PM	329	2
12:29:32 PM	335	2
12:29:42 PM	339	2
12:29:52 PM	345	2
12:30:02 PM	349	2
12:30:12 PM	355	2
12:30:22 PM	337	4
12:30:32 PM	322	5
12:30:42 PM	326	5
12:30:52 PM	334	5
12:31:02 PM	348	5
12:31:12 PM	374	5
12:31:22 PM	414	5
12:31:32 PM	462	5
12:31:42 PM	511	4
12:31:52 PM	554	4



12:32:02 PM	590	4
12:32:12 PM	626	4
12:32:22 PM	658	4
12:32:32 PM	617	4
12:32:42 PM	572	4
12:32:52 PM	528	4
12:33:02 PM	488	4
12:33:12 PM	459	4
12:33:22 PM	441	4
12:33:32 PM	430	4
12:33:42 PM	426	4
12:33:52 PM	425	4
12:34:02 PM	428	4
12:34:12 PM	434	4
12:34:22 PM	441	4
12:34:32 PM	445	4
12:34:42 PM	442	4
12:34:52 PM	436	4
12:35:02 PM	429	4
12:35:12 PM	421	4
12:35:22 PM	412	4
12:35:32 PM	405	4
12:35:42 PM	399	4
12:35:52 PM	392	4
12:36:02 PM	387	4
12:36:12 PM	382	4
12:36:22 PM	376	4
12:36:32 PM	372	4
12:36:42 PM	369	4
12:36:52 PM	366	4
12:37:02 PM	363	4
12:37:12 PM	362	4
12:37:22 PM	360	4
12:37:32 PM	360	4
12:37:42 PM	361	4
12:37:52 PM	361	4
12:38:02 PM	361	4
12:38:12 PM	364	4
12:38:22 PM	367	4
12:38:32 PM	369	4
12:38:42 PM	373	4
12:38:52 PM	377	4
12:39:02 PM	381	4
12:39:12 PM	384	4
12:39:22 PM	386	4
12:39:32 PM	387	4
12:39:42 PM	388	4

12:39:52 PM	388	4
12:40:02 PM	389	4
12:40:12 PM	388	3
12:40:22 PM	386	4
12:40:32 PM	384	3
12:40:42 PM	382	4
12:40:52 PM	378	3
12:41:02 PM	374	3
12:41:12 PM	370	4
12:41:22 PM	364	3
12:41:32 PM	359	3
12:41:42 PM	354	3
12:41:52 PM	350	3
12:42:02 PM	344	3
12:42:12 PM	340	3
12:42:22 PM	337	3
12:42:32 PM	335	3
12:42:42 PM	339	3
12:42:52 PM	351	3
12:43:02 PM	368	3
12:43:12 PM	388	3
12:43:22 PM	410	3
12:43:32 PM	430	3
12:43:42 PM	447	3
12:43:52 PM	464	3
12:44:02 PM	479	3
12:44:12 PM	489	3
12:44:22 PM	481	3
12:44:32 PM	472	3
12:44:42 PM	461	3
12:44:52 PM	450	3
12:45:02 PM	440	3
12:45:12 PM	430	3
12:45:22 PM	420	3
12:45:32 PM	411	3
12:55:32 PM	452	7 5 lbs
1:05:32 PM	471	6
1:15:32 PM	486	5
1:25:32 PM	526	4
1:35:32 PM	428	3
1:45:32 PM	397	2
1:55:32 PM	313	2
2:05:32 PM	356	7 5 lbs
2:15:32 PM	405	6
2:25:32 PM	394	6
2:35:32 PM	381	5
2:45:32 PM	376	4

2:55:32 PM	372	4
3:05:32 PM	377	3
3:15:32 PM	407	7 4 lbs
3:25:32 PM	307	6
3:35:32 PM	344	6
3:45:32 PM	451	5
3:55:32 PM	434	4
4:05:32 PM	405	4
4:15:32 PM	390	3
4:25:32 PM	396	3
4:35:32 PM	361	2
4:45:32 PM	320	2
4:55:32 PM	436	11 9 lbs
5:05:32 PM	372	10
5:15:32 PM	355	9
5:25:32 PM	391	9
5:35:32 PM	358	8
5:45:32 PM	297	7
5:55:32 PM	259	7
6:05:32 PM	244	6
6:15:32 PM	236	6
6:25:32 PM	305	6
6:35:32 PM	306	5
6:45:32 PM	304	5
6:55:32 PM	323	4
7:05:32 PM	319	4
7:15:32 PM	265	4
7:25:32 PM	247	3
7:35:32 PM	240	3
7:45:32 PM	238	3
7:55:32 PM	193	3

Client BUCK  
Model 21  
Run # AGE#6  
Project # BUCK21

Tracking #

Date 7\_13\_16 8 hours

Notes: All Fuel 18-25%

Time	FLUE	SCALE	CH 3
12:13:05 PM	332		9 10 lbs
12:23:05 PM	395		7
12:33:05 PM	389		6
12:43:05 PM	397		5
12:53:05 PM	391		4
1:03:05 PM	398		4
1:13:05 PM	381		3
1:23:05 PM	347		2
1:33:05 PM	353		11 9 lbs
1:43:05 PM	400		10
1:53:05 PM	393		9
2:03:05 PM	379		8
2:13:05 PM	362		8
2:23:05 PM	344		7
2:33:05 PM	336		6
2:43:05 PM	346		6
2:53:05 PM	348		5
3:03:05 PM	349		5
3:13:05 PM	343		4
3:23:05 PM	333		4
3:33:05 PM	291		3
3:43:05 PM	293		11 8 lbs
3:53:05 PM	357		10
4:03:05 PM	412		9
4:13:05 PM	378		9
4:23:05 PM	365		8
4:33:05 PM	349		7
4:43:05 PM	339		7
4:53:05 PM	325		6
5:03:05 PM	316		6
5:13:05 PM	300		5
5:23:05 PM	283		5
5:33:05 PM	283		5
5:43:05 PM	313		4
5:53:05 PM	321		4
6:03:05 PM	300		4
6:13:05 PM	333		12 8 lbs
6:23:05 PM	412		11
6:33:05 PM	409		10

6:43:05 PM	399	9
6:53:05 PM	399	8
7:03:05 PM	390	8
7:13:05 PM	378	7
7:23:05 PM	371	6
7:33:05 PM	365	6
7:43:05 PM	361	5
7:53:05 PM	311	5
8:03:05 PM	265	5
8:13:05 PM	247	5

Client BUCK  
Model 21  
Run # AGE#7  
Project # BUCK21  
Tracking #  
Date 7\_14\_16 7 hours 30 min

Notes: All fuel 18-25%

Time	FLUE	SCALE	CH 3
12:09:29 PM	524		8 9 lbs
12:19:29 PM	498		7
12:29:29 PM	419		6
12:39:29 PM	404		5
12:49:29 PM	382		8
12:59:29 PM	419		7
1:09:29 PM	420		6
1:19:29 PM	386		5
1:29:29 PM	352		5
1:39:29 PM	315		4
1:49:29 PM	283		4
1:59:29 PM	267		4
2:09:29 PM	259		3
2:19:29 PM	240		3
2:29:29 PM	225		3
2:39:29 PM	419		13 10 lbs
2:49:29 PM	439		12
2:59:29 PM	375		11
3:09:29 PM	376		11
3:19:29 PM	368		10
3:29:29 PM	352		9
3:39:29 PM	346		8
3:49:29 PM	358		7
3:59:29 PM	354		7
4:09:29 PM	359		6
4:19:29 PM	367		6
4:29:29 PM	321		5
4:39:29 PM	304		5
4:49:29 PM	263		5
4:59:29 PM	237		4
5:09:29 PM	234		15 11 lbs
5:19:29 PM	269		14
5:29:29 PM	319		13
5:39:29 PM	442		12
5:49:29 PM	396		11
5:59:29 PM	400		10
6:09:29 PM	391		9
6:19:29 PM	375		9
6:29:29 PM	371		8

6:39:29 PM	364	8
6:49:29 PM	357	7
6:59:29 PM	337	6
7:09:29 PM	302	6
7:19:29 PM	289	6
7:29:29 PM	256	6
7:39:29 PM	243	5

8/9/16 EPA #1 9.2 lbs 2 1/8" Setting FAN-LOW

WARM-up 0700-0815 EMPTIED + Zeroed Scale

LOADEN 11.6 lbs of PB fuel

STARTED PB recording @ 08:40 Set to 2 1/8" FAN-LOW

TEST STARTER @ 09:52 P.V. 40 Sec closed @ 40w  
and set on FULL open Primary Fu 4' 20w (FAN OFF)  
Cleaning and 16 min Clean @ 18'

FAN ON @ 20'

1 HR chg FRONT FILTER on TRAIN A

AMB BOX 1509.6 84 → 96°F

8/10/16 EPA Run #2 2 1/16

WARMUP START @ 0650

[07:50] EMPTIED STOVE + Zeroed Scale

PB FUEL LOADED 11.5 lbs

PB Recording START @ 08:20 2 1/16 FAN-LOW

START @ 09:30

Set to 2 1/16 @ 5' FAN OFF

Cleaning @ 16'

FAN ON @ 20'

FILTER CHG @ 1 HR TRAIN A

AMB 1235.09

90 → 98



8/11/16 R3

CAT 3

WARMUP START @ 07:00

2"

FAN ~~MED~~ HIGH

LOADED 11 lbs of PB @ 8:15

PB Weighing Started @ 08:40 (6.5 lbs) 2" Settin FAN on  
MED/HIGH

Test START @ 10:02 D.O. 40 Sec

Primum Full Open for 5 min (Door Closed)

Set to 2" FAN OFF

Clearing @ 10'

FAN ON @ 20' MED/HIGH

FILTER CHG @ 1 HR TRAW A

Amb 90°F

843.53 AMB 98.3°

8/12/16 R4

NIGHT (CAT 4)

WARM-UP START @ 07:00

Emptied + Zeroed Scale

0830 LOADED 11.3 lbs PB FULL OPEN FAN-HIGH

Levelled COOL BED @ 30'

STARTED @ 09:40

FAN ON HIGH @ 20'

FILTER CHG @ 1 HR TRAW A

Amb 501.49 Ltrs

Amb 90° → 94°

8/16/16 FAN CONFIRM RUN #5  
2 1/8"

13:55 Pre-burn Start → 5.9 lbs (Fan off entire Run)

15:07 TEST Start Amb. Box: 81°F

D.O: 30 sec Primary: 5 min Set @ 2 1/8" - @ 5 min

0.7 lbs burnt in 5 min

16:07 Front Filter change (train A)

18:37 Test End Amb box: 1168 995 C 106°F

Project #  MFG   
 Run #  Model   
 Date

**Train A**  
**First Hour**

Front	Rear	Filter #	Tare	Final	Net
<input checked="" type="checkbox"/>		2854	0.1182	0.1217	0.0035
<input type="checkbox"/>	<input checked="" type="checkbox"/>	2855			
<input checked="" type="checkbox"/>	<input type="checkbox"/>	2859	0.2392	0.2398	
<input checked="" type="checkbox"/>	<input type="checkbox"/>	O Ring			
<input type="checkbox"/>	<input checked="" type="checkbox"/>	O Ring	3.5530	3.5532	0.0008
					<b>4.3</b> mg

**Train B**

Front	Rear	Filter #	Tare	Final	Net
<input checked="" type="checkbox"/>	<input type="checkbox"/>	2856			
<input type="checkbox"/>	<input checked="" type="checkbox"/>	2857	0.2409	0.2441	
<input checked="" type="checkbox"/>	<input type="checkbox"/>	O ring			
<input type="checkbox"/>	<input checked="" type="checkbox"/>	O ring	3.5686	3.5692	0.0038
					<b>3.8</b> mg

Nozzle

#	TARE	FINAL	Net
2A	116.2328	116.2319	-0.0009
			0.0

Nozzle

#	TARE	FINAL	Net
2B	116.3260	116.3260	0.0
			0.0

**Train A Total Catch** **4.3**

**Train B Total Catch** **3.8**

**Ambient**

Filter #	Tare	Final	Net	Vol (liter)
2858	0.1182	0.1185	0.0003	1509.6
O ring	1.6485	1.6486	0.0	
Total			0.0003	mg

Notes: Train A Total: 4.3mg    Train B Total: 3.8mg    Ambient Total: 0.3mg    1 Hour Catch: 3.5mg

Project # 037-S-048-6B  
 Run # 2  
 Date 8/17/16

MFG New Buck Corporation  
 Model 21NC

**Train A First Hour**

Front	Rear	Filter #	Tare	Final	Net
<input checked="" type="checkbox"/>	<input type="checkbox"/>	2860	0.1166	0.1226	0.0060
<input type="checkbox"/>	<input checked="" type="checkbox"/>	2861			
<input checked="" type="checkbox"/>	<input type="checkbox"/>	2865	0.2357	0.2361	
<input checked="" type="checkbox"/>	<input type="checkbox"/>	O Ring			
<input type="checkbox"/>	<input checked="" type="checkbox"/>	O Ring	3.5893	3.5894	0.0005
					<b>6.5</b> mg

**Train B**

Front	Rear	Filter #	Tare	Final	Net
<input checked="" type="checkbox"/>	<input type="checkbox"/>	2862			
<input type="checkbox"/>	<input checked="" type="checkbox"/>	2863	0.2375	0.2438	
<input checked="" type="checkbox"/>	<input type="checkbox"/>	O ring			
<input type="checkbox"/>	<input checked="" type="checkbox"/>	O ring	3.5535	3.5539	0.0067
					<b>6.7</b> mg

Nozzle

#	TARE	FINAL	Net
3A	116.0687	116.0687	0.0

Nozzle

#	TARE	FINAL	Net
3B	116.3360	116.3360	0.0

**Train A Total Catch 6.5**

**Train B Total Catch 6.7**

**Ambient**

Filter #	Tare	Final	Net	Vol (liter)
2864	0.1206	0.1208	0.0002	1235.09
O ring	1.6936	1.6938	0.0002	
Total			0.0004	mg

Notes: Train A Total: 6.5mg    Train B Total: 6.7mg    Ambient Total: 0.4mg    1 Hour Catch: 6.0mg

Project # 037-S-048-6B  
 Run # 3  
 Date 8/17/16

MFG New Buck Corporation  
 Model 21NC

**Train A**

Front	Rear	Filter #	Tare	Final	Net
<input checked="" type="checkbox"/>		2866	0.1181	0.1218	0.0037
<input type="checkbox"/>	<input checked="" type="checkbox"/>	2867			
<input checked="" type="checkbox"/>	<input type="checkbox"/>	2871	0.2394	0.2400	
<input checked="" type="checkbox"/>	<input type="checkbox"/>	O Ring			
<input type="checkbox"/>	<input checked="" type="checkbox"/>	O Ring	3.5920	3.5920	0.0006
					<b>4.3</b> mg

**Train B**

Front	Rear	Filter #	Tare	Final	Net
<input checked="" type="checkbox"/>	<input type="checkbox"/>	2868			
<input type="checkbox"/>	<input checked="" type="checkbox"/>	2869	0.2369	0.2402	
<input checked="" type="checkbox"/>	<input type="checkbox"/>	O ring			
<input type="checkbox"/>	<input checked="" type="checkbox"/>	O ring	3.5294	3.5295	0.0034
					<b>3.4</b> mg

Nozzle

#	TARE	FINAL	Net
4A	116.1803	116.1802	-0.0001
			0

Nozzle

#	TARE	FINAL	Net
4B	116.3939	116.3939	0.0
			0.0

**Train A Total Catch 4.3**

**Train B Total Catch 3.4**

**Ambient**

Filter #	Tare	Final	Net	Vol (liter)
2870	0.1217	0.1216	-0.0001	843.53
O ring	1.6647	1.6645	-0.0002	
Total			-0.0003	mg

Notes: Train A Total: 4.3mg      Train B Total: 3.4mg      Ambient Total: 0.0mg      1 Hour Catch: 3.7mg

Project # 037-S-048-6B  
 Run # 4  
 Date 8/17/16

MFG New Buck Corporation  
 Model 21NC

**Train A**

Front	Rear	Filter #	Tare	Final	Net
<input checked="" type="checkbox"/>		2872	0.1180	0.1215	0.0035
<input type="checkbox"/>	<input checked="" type="checkbox"/>	2873			
<input checked="" type="checkbox"/>	<input type="checkbox"/>	2877	0.2369	0.2371	
<input checked="" type="checkbox"/>	<input type="checkbox"/>	O Ring			
<input type="checkbox"/>	<input checked="" type="checkbox"/>	O Ring	3.5835	3.5831	0.0002
					<b>3.7</b> mg

**Train B**

Front	Rear	Filter #	Tare	Final	Net
<input checked="" type="checkbox"/>	<input type="checkbox"/>	2874			
<input type="checkbox"/>	<input checked="" type="checkbox"/>	2875	0.2389	0.2417	
<input checked="" type="checkbox"/>	<input type="checkbox"/>	O ring			
<input type="checkbox"/>	<input checked="" type="checkbox"/>	O ring	3.5691	3.5692	0.0029
					<b>2.9</b> mg

Nozzle

#	TARE	FINAL	Net
5A	116.7701	116.7701	0.0

Nozzle

#	TARE	FINAL	Net
5B	116.8783	116.8783	0.0

**Train A Total Catch** 3.7

**Train B Total Catch** 2.9

**Ambient**

Filter #	Tare	Final	Net	Vol (liter)
2876	0.1217	0.1219	0.0002	501.49
O ring	1.6697	1.6696	0.0	
Total			0.0002	mg

Notes: Train A Total: 3.7mg      Train B Total: 2.9mg      Ambient Total: 0.2mg      1 Hour Catch: 3.5mg

Project # 037-S-048-6B  
 Run # 5  
 Date 8/19/16

MFG New Buck Corporation  
 Model 21

**Train A**

Front	Rear	Filter #	Tare	Final	Net
<input checked="" type="checkbox"/>		2878	0.1195	0.1271	0.0076
<input type="checkbox"/>	<input checked="" type="checkbox"/>	2879			
<input checked="" type="checkbox"/>	<input type="checkbox"/>	2883	0.2429	0.2433	
<input checked="" type="checkbox"/>	<input type="checkbox"/>	O Ring			
<input type="checkbox"/>	<input checked="" type="checkbox"/>	O Ring	3.5454	3.5463	0.0013
					8.9 mg

**Train B**

Front	Rear	Filter #	Tare	Final	Net
<input checked="" type="checkbox"/>	<input type="checkbox"/>	2880			
<input type="checkbox"/>	<input checked="" type="checkbox"/>	2881	0.2412	0.2482	
<input checked="" type="checkbox"/>	<input type="checkbox"/>	O ring			
<input type="checkbox"/>	<input checked="" type="checkbox"/>	O ring	3.5970	3.5976	0.0076
					7.6 mg

Nozzle

#	TARE	FINAL	Net
6A	116.5635	116.5635	0.0

Nozzle

#	TARE	FINAL	Net
6B	116.1181	116.1181	0.0

**Train A Total Catch** 8.9

**Train B Total Catch** 7.6

**Ambient**

Filter #	Tare	Final	Net	Vol (liter)
2882	0.1177	0.1177	0.0	1168.995
O ring	1.6924	1.6927	0.0003	
Total			0.0003 mg	

Notes: Train A Total: 8.9mg      Train B Total: 7.6mg      Ambient Total: 0.3mg      1 Hour Catch: 7.6mg







			1	2	3	4	5	TEMPERATURES	
ET	SCALE READING	FLUE DRAFT	LEFT SIDE	RIGHT SIDE	BACK	TOP	BOTTOM	STOVE AVG T	
			404		144.875				

Run # 

1
---

  
 Date: 

8/9/16
--------

Dilution Tunnel MW(dry): 

29.00
-------

 lb/lb-mole  
 Dilution Tunnel MW(wet): 

28.78
-------

 lb/lb-mole  
 Dilution Tunnel H2O: 

2.00
------

 %  
 Dilution Tunnel Static: 

-0.400
--------

 In H2O  
 Tunnel Area: 

0.196
-------

 ft<sup>2</sup>  
 Pitot Tube Cp: 

0.99
------

Dilution Tunnel Traverse Data								
	Pt.1	Pt.2	Pt.3	Pt.4	Pt.5	Pt.6	Pt.7	Pt.8
dP	0.040	0.040	0.042	0.040	0.038	0.041	0.042	0.042
Temperature	95	95	95	95	95	95	95	95

0.041  
95.000

Tunnel Velocity: 

13.644
--------

 ft/sec.  
 Intial Tunnel Flow: 

150.34
--------

 scfm  
 Average Tunnel Flow: 

152.11
--------

 scfm

JOB #	037-S-048-6																		
TECHNICIAN	GEN																		
DATE:	8_9_16											ROOM TEMP (F)	75.0	BEG	MID	END	AVG		
RUN #:	1											BAROMETRIC		30.03	30.03	30.03	30.03		
READING INTERVAL:	10																		
SAMPLE BOX :	A	METER Y FACTOR:	1.002											PROBE MATERIAL:	SS				
FRONT FILTER #:	2854&2859				REAR FILTER #:	2855													
FINAL LEAK RATE (CFM):	<0.01	@	5	IN-HG	FINAL LEAK RATE (CFM):	<0.01	@	5	IN-HG										
Run Time:	270	AMBIENT FILTER #:				2858	VOLUME	1509.6	LITERS	FUEL MOISTURE DB						20.9	%		
		FINAL LEAK RATE (CFM):				<0.01	@	5	IN-HG										
TEST START TIME:	9:52																		
										TEMPERATURES									
	GAS METER	SAMPLE	TUNNEL	ORIFICE	FILTER	TUNNEL VEL	Proportional	Scale	Weight	TUNNEL	FLUE	FILTER	FB REAR	FB	METER	AMBIENT			
ET	VOLUME	RATE(FT3/MIN)	DELTA P	DELTA H	VAC	FT/SEC	Rate (%)	Weight	Chg	TEMP	TEMP	TEMP	TEMP	INT	TEMP	TEMP			
0	0.000	0.000	0.041	0.01	-0.11		NA	9.2	0	85	196	75	142	4167.94	78	71			
10	1.383	0.138	0.041	2.01	-0.77	13.774	102	8	1.2	102	393	78	153	4167.39	79	72			
20	2.767	0.138	0.041	1.98	-1.35	13.774	102	6.7	1.3	102	420	79	162	4167.04	82	71			
30	4.163	0.140	0.041	2	-0.67	13.749	102	5.4	1.3	100	418	78	134	4166.7	85	71			
40	5.563	0.140	0.041	2.02	-1	13.761	102	4.1	1.3	101	437	79	129	4166.75	88	73			
50	6.966	0.140	0.041	2.03	-1.49	13.749	102	3.1	1	100	404	80	130	4167.31	90	74			
60	8.378	0.141	0.041	2.01	-0.96	13.700	101	2.4	0.7	96	339	80	128	4167.86	93	75			
70	9.790	0.141	0.041	2.03	-0.74	13.650	101	2.1	0.3	92	281	81	126	4168.35	95	75			
80	11.213	0.142	0.041	2.03	-0.7	13.626	101	1.8	0.3	90	256	81	123	4168.84	97	76			
90	12.633	0.142	0.041	2.04	-1.49	13.589	100	1.7	0.1	87	220	80	120	4169.33	99	76			
100	14.063	0.143	0.041	2.04	-1.14	13.576	100	1.5	0.2	86	201	80	118	4169.84	100	76			
110	15.491	0.143	0.041	2.03	-1.48	13.564	100	1.4	0.1	85	189	79	116	4170.41	101	76			
120	16.922	0.143	0.041	2.05	-0.74	13.551	100	1.3	0.1	84	182	79	116	4170.87	102	76			
130	18.358	0.144	0.041	2.04	-1.24	13.551	100	1.2	0.1	84	170	79	117	4171.22	103	76			
140	19.790	0.143	0.041	2.03	-1.2	13.539	100	1	0.2	83	167	79	117	4171.52	103	76			
150	21.224	0.143	0.041	2.01	-1.17	13.539	100	0.9	0.1	83	163	79	116	4171.77	104	76			
160	22.664	0.144	0.041	2.04	-0.88	13.539	100	0.8	0.1	83	159	79	115	4172.02	104	76			
170	24.101	0.144	0.041	2.04	-1.21	13.539	100	0.7	0.1	83	155	78	114	4172.29	105	76			
180	25.536	0.144	0.041	2.02	-1.34	13.539	100	0.7	0	83	151	78	113	4172.53	105	76			
190	26.976	0.144	0.041	2.03	-1.33	13.526	100	0.6	0.1	82	146	78	112	4172.66	105	76			
200	28.416	0.144	0.041	2.04	-0.91	13.526	100	0.4	0.2	82	141	78	111	4172.87	105	76			
210	29.853	0.144	0.041	2.04	-0.71	13.526	99	0.4	0	82	136	78	110	4173.05	106	77			
220	31.292	0.144	0.041	2.06	-1.47	13.526	100	0.4	0	82	133	78	109	4173.31	106	77			
230	32.734	0.144	0.041	2.05	-0.96	13.526	100	0.3	0.1	82	134	78	107	4173.42	106	76			
240	34.174	0.144	0.041	2.05	-0.98	13.526	100	0.2	0.1	82	133	78	106	4173.55	106	77			
250	35.613	0.144	0.041	2.06	-1.12	13.526	100	0.1	0.1	82	129	78	106	4173.66	106	77			
260	37.053	0.144	0.041	2.05	-1.34	13.514	100	0.1	0	81	124	78	105	4173.92	106	77			
270	38.496	0.144	0.041	2.04	-1.02	13.514	100	0	0.1	81	120	78	104	4174.18	106	77			

TEST START TIME:		9:52								1	2	3	4	5	6	
										TEMPERATURES						
ET	GAS METER VOLUME	SAMPLE RATE(FT3/MIN)	TUNNEL DELTA P	ORIFICE DELTA H	FILTER VAC	TUNNEL VEL FT/SEC	Proportional Rate (%)	Scale Weight	Weight Chg	TUNNEL TEMP	FLUE TEMP	FILTER TEMP	FB REAR TEMP	FB INT	METER TEMP	AMBIENT TEMP

TEST START TIME:		9:52								1	2	3	4	5	6	
										TEMPERATURES						
ET	GAS METER VOLUME	SAMPLE RATE(FT3/MIN)	TUNNEL DELTA P	ORIFICE DELTA H	FILTER VAC	TUNNEL VEL FT/SEC	Proportional Rate (%)	Scale Weight	Weight Chg	TUNNEL TEMP	FLUE TEMP	FILTER TEMP	FB REAR TEMP	FB INT	METER TEMP	AMBIENT TEMP
	38.496		0.041	2.03		13.593	100.3			87	218				99	75

JOB #	037-S-048-6								
TECHNICIAN	GEN								
DATE:	8_9_16								
RUN #:	1								
READING INTERVAL:	10								
SAMPLE BOX :	B	METER Y FACTOR:	1.001	PROBE MATERIAL:	SS				
FRONT FILTER #:	2856			REAR FILTER #:	2867				
FINAL LEAK RATE (CFM):	<0.01	@	5	IN-HG	FINAL LEAK RATE (CFM):	<0.01	@	5	IN-HG

Run Time: **270** Firebox Delta T **97.2**

ET	GAS METER VOLUME	SAMPLE RATE(FT3/MIN)	PROPORTIONAL RATE	FLUE DRAFT	ORIFICE DELTA H	FILTER VAC	TEMPERATURES						METER	STOVE AVG T
							1	2	3	4	5	6		
0	0	0	NA	0	0	1	367	376	75	225	165	78	255	
10	1.368	0.137	103	-0.05	1.96	1.37	335	339	78	256	147	79	246	
20	2.737	0.137	103	-0.06	1.96	1.35	325	335	78	308	155	81	257	
30	4.110	0.137	102	-0.06	1.97	1.75	340	344	78	317	153	84	258	
40	5.488	0.138	102	-0.06	1.98	2.02	356	357	79	337	149	87	266	
50	6.877	0.139	102	-0.05	1.98	1.74	373	376	80	358	146	90	277	
60	8.268	0.139	102	-0.04	1.97	1.31	386	384	81	338	145	92	276	
70	9.659	0.139	101	-0.03	1.96	1.39	381	373	80	284	143	95	261	
80	11.055	0.140	101	-0.03	1.97	1.54	368	357	80	244	141	97	247	
90	12.456	0.140	101	-0.02	1.97	1.6	360	342	80	214	141	98	235	
100	13.857	0.140	100	-0.02	1.96	1.92	352	329	79	191	141	100	226	
110	15.259	0.140	100	-0.02	1.98	1.69	348	318	79	177	140	101	220	
120	16.666	0.141	100	-0.01	1.97	1.63	342	309	79	168	139	102	215	
130	18.072	0.141	100	-0.01	1.97	1.89	334	300	79	164	139	103	211	
140	19.478	0.141	100	-0.01	1.99	1.26	327	292	79	161	139	103	207	
150	20.890	0.141	100	-0.01	1.97	1.68	322	284	78	159	139	104	204	
160	22.297	0.141	99	-0.01	1.97	1.55	318	275	78	156	138	104	200	
170	23.708	0.141	100	-0.01	1.98	1.96	312	267	78	153	137	105	197	
180	25.117	0.141	99	-0.01	1.97	1.78	305	260	78	150	135	105	193	
190	26.526	0.141	99	0	1.96	1.96	295	252	78	147	134	106	188	
200	27.938	0.141	99	-0.01	1.96	1.94	285	243	78	143	134	106	183	
210	29.349	0.141	99	-0.01	1.95	1.72	274	233	78	139	132	106	178	
220	30.762	0.141	99	-0.01	1.96	1.4	268	223	78	136	131	106	173	

ET	GAS METER VOLUME	SAMPLE RATE(FT3/MIN)	PROPORTIONAL RATE	FLUE DRAFT	ORIFICE DELTA H	FILTER VAC	1	2	3	4	5	6	STOVE AVG T
							TEMPERATURES						
230	32.172	0.141	99	-0.01	1.97	2	262	216	78	133	129	106	169
240	33.586	0.141	100	0	1.99	1.64	258	213	78	132	127	106	167
250	34.997	0.141	99	-0.01	1.97	1.65	251	211	78	130	126	107	165
260	36.408	0.141	99	0	1.97	1.63	241	207	78	128	125	107	161
270	37.820	0.141	99	0	1.97	1.52	233	201	78	126	125	107	158

							1	2	3	4	5	6		
							TEMPERATURES							
ET	GAS METER VOLUME	SAMPLE RATE(FT3/MIN)	PROPORTIONAL RATE	FLUE DRAFT	ORIFICE DELTA H	FILTER VAC	LEFT SIDE	RIGHT SIDE	FILTER	FB TOP	FB BOT	METER	STOVE AVG T	
	37.82	0.140	100.261	-0.020	1.96963	1.638929	319	293	79	199	139	99	97	
	TOTAL	AVG	AVG	AVG	AVG	AVG	AVG	AVG	AVG	AVG	AVG	AVG	<b>DT</b>	

157.8



# Ambient Sample Results:

JOB NUMBER: 037-S-048-6  
 TECHNICIAN: GEN  
 DATE: 8\_9\_16  
 RUN NUMBER: 1

METER Y FACTOR: 1.003

	<u>Sample Volume (L)</u>	<u>Meter Temp °F</u>	<u>ΔH</u>	<u>ΔP</u>
Start	0	84	0	0
End	1509.6	96	0	0

SAMPLE INFORMATION	
Total Sample Volume - Vm	1509.600 Liters
Total Sample Volume - Vm	53.311 ft <sup>3</sup>
Average Sample Rate	0.20 ft <sup>3</sup> /min
Sample Time	270.00 Minutes
Average Meter Temperature	90 °F
Total Sample Volume (Standard Conditions) - Vmstd	51.521 dscf
Total Particulates	<span style="border: 1px solid black; padding: 2px;">0.3</span> mg
Particulate Concentration (dry-standard)	<span style="border: 1px solid black; padding: 2px;">0.000005823</span> grams/dscf
Particulate Emission Rate	<span style="border: 1px solid black; padding: 2px;">0.000066667</span> grams/hour

JOB NUMBER 037-S-048-6

RUN # 1  
 DATE: 8\_9\_16

BURN RATE 0.77 KG/HR DRY

FILTER A PARTICULATE 4.4 mg

FILTER B PARTICULATE 3.8 mg

Total Sample Volume - Vm  
 Average Gas Velocity in Dilution Tunnel - vs  
 Average Gas Flow Rate in Dilution Tunnel - Qsd  
 Total Sample Volume (Standard Conditions) - Vmstd

Average Tunnel Temperature  
 Average Delta p

Average Gas Meter Temperature  
 Average Delta H  
 Total Time of Test

Total Particulates

Particulate Concentration (dry-standard)  
**Ambient Train (dry-standard)**  
**Net (dry-standard)**  
 Particulate Emission Rate  
 Total PM Emissions

Average Total PM Emissions  
 AVERAGE PARTICULATE  
 EMISSIONS RATE

% OF AVERAGE

Emissions Factor

SAMPLE A INFORMATION		SAMPLE B INFORMATION	
38.50		37.82	
13.64	feet/second	13.64	feet/second
9126.36	dscf/hour	9126.36	dscf/hour
36.77	dscf	36.08	dscf
87.3	F	87.3	F
0.041		0.041	
99	F	99	F
2.03	in-h20	1.97	in-h20
270	min	270	min
4.4	mg	3.8	mg
0.00012	grams/dscf	0.00011	grams/dscf
0.000005823	grams/dscf	0.000005823	grams/dscf
0.000113852	grams/dscf	9.95014E-05	grams/dscf
1.04	grams/hour	0.91	grams/hour
4.68	grams	4.09	grams
		4.38	grams
		0.97	grams/hour
106.7		93.3	
1.355	g/Kg -Dry	1.184	g/Kg -Dry

PREBURN

JOB # 037-S-048-6

Model Designation BUCK 21NC

TECHNICIAN IGEN

DATE: 8\_10\_16

RUN #: 2

READING INTERVAL: 10

Tunnel Traverse Information

	Pt.1	Pt.2	Pt.3	Pt.4	Pt.5	Pt.6	Pt.7	Pt.8	
dP	0.040	0.043	0.042	0.040	0.040	0.041	0.042	0.043	0.041
Temperature	95	95	95	95	95	95	95	95	95.000

Run Time: 70

ET	SCALE READING	FLUE DRAFT	TEMPERATURES					STOVE AVG T
			1 LEFT SIDE	2 RIGHT SIDE	3 BACK	4 TOP	5 BOTTOM	
0	5.8	-0.08	447	411	134	408	142	308.4
10	4.6	-0.067	478	447	140	416	151	326.4
20	3.7	-0.054	479	455	142	381	152	321.8
30	3.2	-0.05	457	459	145	324	161	309.2
40	3.1	-0.041	443	436	145	276	166	293.2
50	2.7	-0.034	429	413	145	241	171	279.8
60	2.6	-0.029	408	395	154	228	182	273.4
70	2.5	-0.025	377	360	140	202	176	251

Dilution Tunnel MW(dry): **29.00** lb/lb-mole  
 Dilution Tunnel MW(wet): **28.78** lb/lb-mole  
 Dilution Tunnel H2O: **2.00** %  
 Dilution Tunnel Static: **-0.400** In H2O  
 Tunnel Area: **0.196** ft<sup>2</sup>  
 Pitot Tube Cp: **0.99**

Tunnel Velocity: 13.71376 ft/sec.  
 Initial Tunnel Flow: 151.7482 scfm  
 Average Tunnel Flow: 151.3364 scfm

Notes:

ET	SCALE READING	FLUE DRAFT	1	2	3	4	5	STOVE AVG T											
			TEMPERATURES																
			LEFT SIDE	RIGHT SIDE	BACK	TOP	BOTTOM												
			439.75		143.125														

Run #   
 Date:

Dilution Tunnel MW(dry):  lb/lb-mole  
 Dilution Tunnel MW(wet):  lb/lb-mole  
 Dilution Tunnel H2O:  %  
 Dilution Tunnel Static:  In H2O  
 Tunnel Area:  ft<sup>2</sup>  
 Pitot Tube Cp:

Dilution Tunnel Traverse Data								
	Pt.1	Pt.2	Pt.3	Pt.4	Pt.5	Pt.6	Pt.7	Pt.8
dP	0.040	0.043	0.042	0.040	0.040	0.041	0.042	0.043
Temperature	95	95	95	95	95	95	95	95

0.041  
95.000

Tunnel Velocity:  ft/sec.  
 Intial Tunnel Flow:  scfm  
 Average Tunnel Flow:  scfm

JOB #	037-S-048-6																		
TECHNICIAN	GEN																		
DATE:	8_10_16											ROOM TEMP (F)	77.3	BEG	MID	END	AVG		
RUN #:	2											BAROMETRIC		30.04	30.04	30.04	30.04		
READING INTERVAL:	10																		
SAMPLE BOX :	A	METER Y FACTOR:	1.002											PROBE MATERIAL:	SS				
FRONT FILTER #:	2860&2865				REAR FILTER #:	2861													
FINAL LEAK RATE (CFM):	<0.01	@	5	IN-HG	FINAL LEAK RATE (CFM):	<0.01	@	5	IN-HG										
Run Time:	220	AMBIENT FILTER #:				2864	VOLUME	1235.09	LITERS	FUEL MOISTURE DB						19.7	%		
		FINAL LEAK RATE (CFM):				<0.01	@	5	IN-HG										
TEST START TIME:	9:30																		
										TEMPERATURES									
	GAS METER	SAMPLE	TUNNEL	ORIFICE	FILTER	TUNNEL VEL	Proportional	Scale	Weight	TUNNEL	FLUE	FILTER	FB REAR	FB	METER	AMBIENT			
ET	VOLUME	RATE(FT3/MIN)	DELTA P	DELTA H	VAC	FT/SEC	Rate (%)	Weight	Chg	TEMP	TEMP	TEMP	TEMP	INT	TEMP	TEMP			
0	0.000	0.000	0.041	0	-0.02		NA	9.6	0	89	210	76	141	4167.66	77	75			
10	1.377	0.138	0.041	1.99	-0.84	13.747	101	8.4	1.2	100	326	80	156	4168.15	79	75			
20	2.759	0.138	0.041	1.98	-1.34	13.808	101	7.3	1.1	105	497	82	155	4168.58	82	75			
30	4.139	0.138	0.041	1.96	-0.74	13.869	101	5.5	1.8	110	514	83	135	4169.05	85	76			
40	5.540	0.140	0.041	2.05	-0.88	13.893	102	3.9	1.6	112	518	84	134	4169.55	89	76			
50	6.952	0.141	0.041	2.03	-0.93	13.832	102	2.9	1	107	440	84	137	4170.11	92	77			
60	8.364	0.141	0.041	2.02	-0.86	13.771	101	2.2	0.7	102	381	84	138	4170.66	94	77			
70	9.791	0.143	0.041	2.04	-0.82	13.722	101	1.9	0.3	98	338	84	136	4171.2	97	77			
80	11.212	0.142	0.041	2.04	-0.98	13.685	100	1.6	0.3	95	303	83	134	4171.7	98	78			
90	12.640	0.143	0.041	2.01	-1.5	13.661	100	1.4	0.2	93	268	83	132	4172.19	100	78			
100	14.072	0.143	0.041	2.04	-0.78	13.623	100	1.2	0.2	90	224	82	128	4172.66	101	78			
110	15.502	0.143	0.041	2.03	-0.73	13.599	100	1.4	-0.2	88	207	81	124	4173.17	102	78			
120	16.938	0.144	0.041	2.06	-0.71	13.599	100	1	0.4	88	200	81	123	4173.64	103	78			
130	18.375	0.144	0.041	2.05	-1.53	13.599	100	0.9	0.1	88	212	81	121	4173.92	104	78			
140	19.810	0.144	0.041	2.05	-0.71	13.599	100	0.8	0.1	88	208	81	120	4174.22	104	78			
150	21.248	0.144	0.041	2.05	-1.26	13.586	100	0.6	0.2	87	204	80	118	4174.53	105	78			
160	22.689	0.144	0.041	2.04	-0.81	13.586	100	0.5	0.1	87	199	80	117	4174.79	105	78			
170	24.127	0.144	0.041	2.05	-1.14	13.586	99	0.4	0.1	87	191	80	116	4175.03	106	78			
180	25.564	0.144	0.041	2.03	-0.8	13.574	99	0.3	0.1	86	181	80	115	4175.22	106	78			
190	27.006	0.144	0.041	2.05	-1.24	13.574	100	0.2	0.1	86	173	80	113	4175.46	106	78			
200	28.448	0.144	0.041	2.04	-0.79	13.561	99	0.2	0	85	169	80	112	4175.64	106	78			
210	29.887	0.144	0.041	2.04	-1.43	13.561	99	0.1	0.1	85	169	80	111	4175.75	106	78			
220	31.327	0.144	0.041	2.05	-1.07	13.561	99	0	0.1	85	164	80	111	4175.88	106	78			

TEST START TIME:		9:30								1	2	3	4	5	6	
										TEMPERATURES						
	GAS METER	SAMPLE	TUNNEL	ORIFICE	FILTER	TUNNEL VEL	Proportional	Scale	Weight	TUNNEL	FLUE	FILTER	FB REAR	FB	METER	AMBIENT
ET	VOLUME	RATE(FT3/MIN)	DELTA P	DELTA H	VAC	FT/SEC	Rate (%)	Weight	Chg	TEMP	TEMP	TEMP	TEMP	INT	TEMP	TEMP

TEST START TIME:		9:30								1	2	3	4	5	6	
										TEMPERATURES						
	GAS METER	SAMPLE	TUNNEL	ORIFICE	FILTER	TUNNEL VEL	Proportional	Scale	Weight	TUNNEL	FLUE	FILTER	FB REAR	FB	METER	AMBIENT
ET	VOLUME	RATE(FT3/MIN)	DELTA P	DELTA H	VAC	FT/SEC	Rate (%)	Weight	Chg	TEMP	TEMP	TEMP	TEMP	INT	TEMP	TEMP
	31.327		0.041	2.03		13.664	100.2			93	274				98	77



JOB #	037-S-048-6								
TECHNICIAN	GEN								
DATE:	8_10_16								
RUN #:	2								
READING INTERVAL:	10								
SAMPLE BOX :		METER Y FACTOR:	1.001	PROBE MATERIAL:			SS		
FRONT FILTER #:	2862			REAR FILTER #:	2863				
FINAL LEAK RATE (CFM):	<0.01	@	5	IN-HG	FINAL LEAK RATE (CFM):	<0.01	@	5	IN-HG

Run Time: **220** Firebox Delta T **65.4**

ET	GAS METER VOLUME	SAMPLE RATE(FT3/MIN)	PROPORTIONAL RATE	FLUE DRAFT	ORIFICE DELTA H	FILTER VAC	1	2	3	4	5	6	METER	STOVE AVG T
							TEMPERATURES							
							LEFT SIDE	RIGHT SIDE	FILTER	FB TOP	FB BOT			
0	0	0	NA	0	0	1	371	353	76	200	164	77	246	
10	1.366	0.137	102	-0.04	1.97	1.62	338	319	80	240	158	78	242	
20	2.734	0.137	102	-0.07	1.97	1.44	316	300	81	256	170	81	239	
30	4.099	0.137	101	-0.06	1.94	1.63	348	328	83	338	158	84	261	
40	5.476	0.138	102	-0.07	1.98	1.78	378	356	84	387	155	88	282	
50	6.860	0.138	101	-0.05	1.96	2.08	405	387	84	396	154	91	296	
60	8.249	0.139	101	-0.05	1.96	1.47	413	404	84	346	154	94	291	
70	9.648	0.140	101	-0.05	2.01	1.71	414	403	83	303	155	96	282	
80	11.057	0.141	101	-0.04	2.01	2.13	411	395	83	267	155	98	272	
90	12.473	0.142	101	-0.03	2.02	2.11	409	388	82	240	154	99	265	
100	13.887	0.141	100	-0.03	2	2.13	399	375	82	213	153	101	254	
110	15.306	0.142	100	-0.02	2.02	1.76	382	360	81	192	150	102	242	
120	16.723	0.142	100	-0.02	2.02	1.37	367	346	81	181	149	103	233	
130	18.145	0.142	100	-0.02	2.01	1.29	355	333	81	173	147	104	226	
140	19.563	0.142	100	-0.02	2.01	1.45	344	323	80	168	144	104	220	
150	20.986	0.142	100	-0.02	2.02	2.1	335	312	80	163	142	105	214	
160	22.407	0.142	100	-0.03	2	1.57	327	304	80	159	139	105	209	
170	23.831	0.142	100	-0.02	2.01	2.17	319	293	80	155	139	106	204	
180	25.254	0.142	99	-0.02	1.99	1.8	312	281	80	151	138	106	199	
190	26.676	0.142	99	-0.02	2.01	1.48	302	269	80	147	136	106	193	
200	28.101	0.143	99	-0.02	2	1.57	293	257	80	143	136	106	188	
210	29.525	0.142	99	-0.01	2	1.74	286	247	80	141	134	107	184	
220	30.952	0.143	99	-0.01	2	1.9	280	239	80	138	134	107	180	

ET	GAS METER VOLUME	SAMPLE RATE(FT3/MIN)	PROPORTIONAL RATE	FLUE DRAFT	ORIFICE DELTA H	FILTER VAC	1	2	3	4	5	6	METER	STOVE AVG T					
							TEMPERATURES								LEFT SIDE	RIGHT SIDE	FILTER	FB TOP	FB BOT
							TEMPERATURES	TEMPERATURES	TEMPERATURES	TEMPERATURES	TEMPERATURES	TEMPERATURES							

							1	2	3	4	5	6		
							TEMPERATURES							
ET	GAS METER VOLUME	SAMPLE RATE(FT3/MIN)	PROPORTIONAL RATE	FLUE DRAFT	ORIFICE DELTA H	FILTER VAC	LEFT SIDE	RIGHT SIDE	FILTER	FB TOP	FB BOT	METER	STOVE AVG T	
	30.952	0.141	100.227	-0.031	1.995909	1.708696	352	329	81	222	149	98	65	
	TOTAL	AVG	AVG	AVG	AVG	AVG	AVG	AVG	AVG	AVG	AVG	AVG	<b>DT</b>	

180.4

# Ambient Sample Results:

JOB NUMBER: 037-S-048-6  
 TECHNICIAN: GEN  
 DATE: 8\_10\_16  
 RUN NUMBER: 2

METER Y FACTOR: 1.003

	<u>Sample Volume (L)</u>	<u>Meter Temp °F</u>	<u>ΔH</u>	<u>ΔP</u>
Start	0	90	0	0
End	1235.09	98	0	0

SAMPLE INFORMATION	
Total Sample Volume - Vm	1235.090 Liters
Total Sample Volume - Vm	43.617 ft <sup>3</sup>
Average Sample Rate	0.20 ft <sup>3</sup> /min
Sample Time	220.00 Minutes
Average Meter Temperature	94 °F
Total Sample Volume (Standard Conditions) - Vmstd	41.862 dscf
Total Particulates	<span style="border: 1px solid black; padding: 2px;">0.4</span> mg
Particulate Concentration (dry-standard)	<span style="border: 1px solid black; padding: 2px;">0.000009555</span> grams/dscf
Particulate Emission Rate	<span style="border: 1px solid black; padding: 2px;">0.000109091</span> grams/hour

JOB NUMBER 037-S-048-6

RUN # 2  
 DATE: 8\_10\_16

BURN RATE 0.99 KG/HR DRY

FILTER A PARTICULATE 6.5 mg

FILTER B PARTICULATE 6.7 mg

Total Sample Volume - Vm  
 Average Gas Velocity in Dilution Tunnel - vs  
 Average Gas Flow Rate in Dilution Tunnel - Qsd  
 Total Sample Volume (Standard Conditions) - Vmstd

Average Tunnel Temperature  
 Average Delta p

Average Gas Meter Temperature  
 Average Delta H  
 Total Time of Test

Total Particulates

Particulate Concentration (dry-standard)  
**Ambient Train (dry-standard)**  
**Net (dry-standard)**  
 Particulate Emission Rate  
 Total PM Emissions

Average Total PM Emissions  
 AVERAGE PARTICULATE  
 EMISSIONS RATE

% OF AVERAGE

Emissions Factor

SAMPLE A INFORMATION		SAMPLE B INFORMATION	
31.33		30.95	
13.71	feet/second	13.71	feet/second
9080.18	dscf/hour	9080.18	dscf/hour
29.97	dscf	29.59	dscf
93.1	F	93.1	F
0.041		0.041	
98	F	98	F
2.03	in-h20	2.00	in-h20
220	min	220	min
6.5	mg	6.7	mg
0.00022	grams/dscf	0.00023	grams/dscf
0.000009555	grams/dscf	0.000009555	grams/dscf
0.000207315	grams/dscf	0.000216854	grams/dscf
1.88	grams/hour	1.97	grams/hour
6.90	grams	7.22	grams
		7.06	grams
		1.93	grams/hour
97.8		102.2	
1.897	g/Kg -Dry	1.985	g/Kg -Dry

# PREBURN

JOB # 037-S-048-6 B

Model Designation BUCK 21NC

TECHNICIAN IGEN

DATE: 8\_11\_16

RUN #: 3

READING INTERVAL: 10

.

Run Time: 80

Tunnel Traverse Information									
	Pt.1	Pt.2	Pt.3	Pt.4	Pt.5	Pt.6	Pt.7	Pt.8	
dP	0.038	0.044	0.042	0.040	0.041	0.044	0.042	0.041	0.042
Temperature	110	110	110	110	110	110	110	110	110.000

ET	SCALE READING	FLUE DRAFT	1	2	3	4	5	STOVE AVG T
			TEMPERATURES					
			LEFT SIDE	RIGHT SIDE	BACK	TOP	BOTTOM	
0	6.5	-0.072	495	371	131	345	177	303.8
10	5.2	-0.067	514	387	134	342	178	311
20	4.2	-0.064	522	416	135	317	177	313.4
30	3.5	-0.057	502	437	135	294	177	309
40	3.1	-0.045	470	425	133	255	175	291.6
50	2.7	-0.048	443	404	135	231	150	272.6
60	2.5	-0.039	418	394	158	260	171	280.2
70	2.3	-0.032	392	380	149	234	193	269.6
80	2.2	-0.029	358	347	129	191	176	240.2

Dilution Tunnel MW(dry): 29.00 lb/lb-mole  
 Dilution Tunnel MW(wet): 28.78 lb/lb-mole  
 Dilution Tunnel H2O: 2.00 %  
 Dilution Tunnel Static: -0.400 In H2O  
 Tunnel Area: 0.196 ft<sup>2</sup>  
 Pitot Tube Cp: 0.99

Tunnel Velocity: 13.89614 ft/sec.  
 Initial Tunnel Flow: 149.9421 scfm  
 Average Tunnel Flow: 152.9928 scfm

Notes:

			1	2	3	4	5																			
			TEMPERATURES																							
ET	SCALE READING	FLUE DRAFT	LEFT SIDE	RIGHT SIDE	BACK	TOP	BOTTOM	STOVE AVG T																		
			457.1111		137.6667																					

Run # 3  
 Date: 8/11/16

Dilution Tunnel MW(dry): 29.00 lb/lb-mole  
 Dilution Tunnel MW(wet): 28.78 lb/lb-mole  
 Dilution Tunnel H2O: 2.00 %  
 Dilution Tunnel Static: -0.400 In H2O  
 Tunnel Area: 0.196 ft<sup>2</sup>  
 Pitot Tube Cp: 0.99

Dilution Tunnel Traverse Data								
	Pt.1	Pt.2	Pt.3	Pt.4	Pt.5	Pt.6	Pt.7	Pt.8
dP	0.038	0.044	0.042	0.040	0.041	0.044	0.042	0.041
Temperature	110	110	110	110	110	110	110	110

0.042  
110.000

Tunnel Velocity: 13.896 ft/sec.  
 Intial Tunnel Flow: 149.94 scfm  
 Average Tunnel Flow: 152.99 scfm



JOB #	037-S-048-6 B																		
TECHNICIAN	GEN																		
DATE:	8_11_16											ROOM TEMP (F)	72.9	BEG	MID	END	AVG		
RUN #:	3											BAROMETRIC		30.04	30.04	30.04	30.04		
READING INTERVAL:	10																		
SAMPLE BOX :	A	METER Y FACTOR:	1.002											PROBE MATERIAL:	SS				
FRONT FILTER #:	2866&2871				REAR FILTER #:	2867													
FINAL LEAK RATE (CFM):	<0.01	@	5	IN-HG	FINAL LEAK RATE (CFM):	<0.01	@	5	IN-HG										
Run Time:	150	AMBIENT FILTER #:				2870	VOLUME	843.53	LITERS	FUEL MOISTURE DB						21.3	%		
		FINAL LEAK RATE (CFM):				<0.01	@	5	IN-HG										
TEST START TIME:	10:02																		
										TEMPERATURES									
	GAS METER	SAMPLE	TUNNEL	ORIFICE	FILTER	TUNNEL VEL	Proportional	Scale	Weight	TUNNEL	FLUE	FILTER	FB REAR	FB	METER	AMBIENT			
ET	VOLUME	RATE(FT3/MIN)	DELTA P	DELTA H	VAC	FT/SEC	Rate (%)	Weight	Chg	TEMP	TEMP	TEMP	TEMP	INT	TEMP	TEMP			
0	0.000	0.000	0.042	0	-0.08		NA	9	0	83	202	73	126	4162.9	75	72			
10	1.373	0.137	0.042	2	-1.48	13.839	100	8.1	0.9	94	346	76	138	4162.95	76	71			
20	2.763	0.139	0.042	2.03	-0.86	14.000	102	6.3	1.8	107	500	79	147	4163.06	79	71			
30	4.158	0.140	0.042	2.03	-0.86	14.037	102	4.7	1.6	110	531	80	126	4163.14	82	72			
40	5.555	0.140	0.042	2	-1.37	14.062	102	3.1	1.6	112	545	80	125	4163.36	85	72			
50	6.961	0.141	0.042	2.01	-1.56	13.988	101	2.2	0.9	106	457	79	127	4163.65	88	73			
60	8.368	0.141	0.042	2.03	-1.53	13.901	101	1.6	0.6	99	378	79	127	4163.93	90	73			
70	9.785	0.142	0.042	2.03	-1.33	13.839	100	1.4	0.2	94	321	80	124	4164.22	92	73			
80	11.202	0.142	0.042	2.02	-1.24	13.801	100	1.1	0.3	91	294	79	121	4164.6	94	73			
90	12.623	0.142	0.042	2.03	-0.89	13.789	100	1	0.1	90	273	78	119	4165	95	73			
100	14.044	0.142	0.042	2.03	-1.08	13.764	99	0.8	0.2	88	257	78	117	4165.35	96	73			
110	15.469	0.143	0.042	2.03	-1.18	13.751	99	0.7	0.1	87	242	78	115	4165.85	97	74			
120	16.893	0.142	0.042	2.05	-0.75	13.751	99	0.5	0.2	87	253	77	115	4166.27	98	74			
130	18.323	0.143	0.042	2.05	-0.73	13.764	100	0.3	0.2	88	251	78	116	4166.69	99	74			
140	19.749	0.143	0.042	2.04	-1.1	13.751	99	0.2	0.1	87	243	78	115	4167.12	99	74			
150	21.179	0.143	0.042	2.01	-1.38	13.751	99	0.1	0.1	87	234	78	115	4167.67	100	74			



TEST START TIME:		10:02								1	2	3	4	5	6	
										TEMPERATURES						
	GAS METER	SAMPLE	TUNNEL	ORIFICE	FILTER	TUNNEL VEL	Proportional	Scale	Weight	TUNNEL	FLUE	FILTER	FB REAR	FB	METER	AMBIENT
ET	VOLUME	RATE(FT3/MIN)	DELTA P	DELTA H	VAC	FT/SEC	Rate (%)	Weight	Chg	TEMP	TEMP	TEMP	TEMP	INT	TEMP	TEMP
	21.179		0.042	2.03		13.852	100.3			94	333				90	73

JOB #	037-S-048-6 B								
TECHNICIAN	GEN								
DATE:	8_11_16								
RUN #:	3								
READING INTERVAL:	10								
SAMPLE BOX :	B	METER Y FACTOR:	1.001	PROBE MATERIAL:	SS				
FRONT FILTER #:	2868			REAR FILTER #:	2869				
FINAL LEAK RATE (CFM):	<0.01	@	5	IN-HG	FINAL LEAK RATE (CFM):	<0.01	@	5	IN-HG

Run Time: 150 Firebox Delta T **21.8**

ET	GAS METER VOLUME	SAMPLE RATE (FT3/MIN)	PROPORTIONAL RATE	FLUE DRAFT	ORIFICE DELTA H	FILTER VAC	TEMPERATURES						METER	STOVE AVG T
							1	2	3	4	5	6		
0	0	0	NA	0	0	1	352	338	73	184	172	75	234	
10	1.363	0.136	101	-0.05	1.98	1.97	317	304	76	198	148	76	221	
20	2.730	0.137	102	-0.07	1.97	1.39	332	324	79	292	164	78	252	
30	4.096	0.137	102	-0.07	1.95	1.62	358	350	79	317	151	81	260	
40	5.473	0.138	102	-0.07	1.99	1.47	396	380	80	362	147	84	282	
50	6.852	0.138	101	-0.06	1.98	2.03	429	410	79	349	147	87	292	
60	8.236	0.138	100	-0.05	1.97	2.04	442	423	79	300	147	90	288	
70	9.623	0.139	100	-0.05	1.97	1.72	437	412	79	251	146	91	274	
80	11.015	0.139	100	-0.04	1.97	2	417	396	78	215	146	93	259	
90	12.408	0.139	99	-0.04	1.97	2	399	383	78	193	144	95	248	
100	13.803	0.140	99	-0.03	1.98	1.73	381	369	77	178	144	96	238	
110	15.203	0.140	99	-0.03	1.97	2.03	368	358	77	169	142	97	230	
120	16.604	0.140	99	-0.03	1.97	1.46	351	348	77	164	141	97	224	
130	18.007	0.140	99	-0.03	1.98	2.02	340	343	77	161	140	98	220	
140	19.409	0.140	99	-0.03	1.97	1.86	332	338	77	160	140	99	217	
150	20.813	0.140	99	-0.02	1.98	1.76	322	330	78	157	139	99	213	

							1	2	3	4	5	6			
							TEMPERATURES								
ET	GAS METER VOLUME	SAMPLE RATE(FT3/MIN)	PROPORTIONAL RATE	FLUE DRAFT	ORIFICE DELTA H	FILTER VAC	LEFT SIDE	RIGHT SIDE	FILTER	FB TOP	FB BOT	METER	STOVE AVG T		

							1	2	3	4	5	6		
							TEMPERATURES							
ET	GAS METER VOLUME	SAMPLE RATE(FT3/MIN)	PROPORTIONAL RATE	FLUE DRAFT	ORIFICE DELTA H	FILTER VAC	LEFT SIDE	RIGHT SIDE	FILTER	FB TOP	FB BOT	METER	STOVE AVG T	
	20.813	0.139	100.275	-0.042	1.973333	1.75625	373	363	78	228	147	90	22	
	TOTAL	AVG	AVG	AVG	AVG	AVG	AVG	AVG	AVG	AVG	AVG	AVG	<b>DT</b>	

212.6

# Ambient Sample Results:

JOB NUMBER: 037-S-048-6 B  
 TECHNICIAN: GEN  
 DATE: 8\_11\_16  
 RUN NUMBER: 3

METER Y FACTOR: 1.003

	<u>Sample Volume (L)</u>	<u>Meter Temp °F</u>	<u>ΔH</u>	<u>ΔP</u>
Start	0	90	0	0
End	843.53	98.3	0	0

SAMPLE INFORMATION	
Total Sample Volume - Vm	843.530 Liters
Total Sample Volume - Vm	29.789 ft <sup>3</sup>
Average Sample Rate	0.20 ft <sup>3</sup> /min
Sample Time	150.00 Minutes
Average Meter Temperature	94.15 °F
Total Sample Volume (Standard Conditions) - Vmstd	28.583 dscf
Total Particulates	<span style="border: 1px solid black; padding: 2px;">0.0</span> mg
Particulate Concentration (dry-standard)	<span style="border: 1px solid black; padding: 2px;">0.000000000</span> grams/dscf
Particulate Emission Rate	<span style="border: 1px solid black; padding: 2px;">0.000000000</span> grams/hour

JOB NUMBER 037-S-048-6 B

RUN # 3  
 DATE: 8\_11\_16

BURN RATE 1.35 KG/HR DRY

FILTER A PARTICULATE 4.3 mg

FILTER B PARTICULATE 3.4 mg

Total Sample Volume - Vm  
 Average Gas Velocity in Dilution Tunnel - vs  
 Average Gas Flow Rate in Dilution Tunnel - Qsd  
 Total Sample Volume (Standard Conditions) - Vmstd

Average Tunnel Temperature  
 Average Delta p

Average Gas Meter Temperature  
 Average Delta H  
 Total Time of Test

Total Particulates

Particulate Concentration (dry-standard)  
**Ambient Train (dry-standard)**  
**Net (dry-standard)**

Particulate Emission Rate  
 Total PM Emissions

Average Total PM Emissions  
 AVERAGE PARTICULATE  
 EMISSIONS RATE

% OF AVERAGE

Emissions Factor

SAMPLE A INFORMATION		SAMPLE B INFORMATION	
21.18		20.81	
13.90	feet/second	13.90	feet/second
9179.57	dscf/hour	9179.57	dscf/hour
20.54	dscf	20.19	dscf
94.4	F	94.4	F
0.042		0.042	
90	F	90	F
2.03	in-h20	1.97	in-h20
150	min	150	min
4.3	mg	3.4	mg
0.00021	grams/dscf	0.00017	grams/dscf
0.000000000	grams/dscf	0.000000000	grams/dscf
0.000209307	grams/dscf	0.000168427	grams/dscf
1.92	grams/hour	1.55	grams/hour
4.80	grams	3.87	grams
		4.33	grams
		1.73	grams/hour
110.8		89.2	
1.427	g/Kg -Dry	1.148	g/Kg -Dry



PREBURN

JOB # 032-S-048-6 B

Model Designation BUCK 21

TECHNICIAGEN

DATE: 8\_12\_16

RUN #: 4

READING INTERVAL: 10

Run Time: 70

Tunnel Traverse Information									
	Pt.1	Pt.2	Pt.3	Pt.4	Pt.5	Pt.6	Pt.7	Pt.8	
dP	0.038	0.044	0.042	0.040	0.041	0.044	0.042	0.041	0.042
Temperature	110	110	110	110	110	110	110	110	110.000

ET	SCALE READING	FLUE DRAFT	TEMPERATURES					STOVE AVG T
			1 LEFT SIDE	2 RIGHT SIDE	3 BACK	4 TOP	5 BOTTOM	
0	11.1	-0.055	399	404	142	241	167	270.6
10	8.2	-0.089	387	396	130	307	154	274.8
20	5.9	-0.085	427	432	133	400	153	309
30	4	-0.081	464	471	140	428	154	331.4
40	2.9	-0.069	482	493	189	475	161	360
50	2.5	-0.056	457	469	210	410	171	343.4
60	2.2	-0.05	420	445	161	301	164	298.2
70	2.2	-0.038	391	405	136	228	155	263

Dilution Tunnel MW(dry): 29.00 lb/lb-mole  
 Dilution Tunnel MW(wet): 28.78 lb/lb-mole  
 Dilution Tunnel H2O: 2.00 %  
 Dilution Tunnel Static: -0.400 In H2O  
 Tunnel Area: 0.196 ft<sup>2</sup>  
 Pitot Tube Cp: 0.99

Tunnel Velocity: 14.35129 ft/sec.  
 Intial Tunnel Flow: 149.8171 scfm  
 Average Tunnel Flow: 148.1407 scfm

Notes:



Run #   
 Date:

Dilution Tunnel MW(dry):  lb/lb-mole  
 Dilution Tunnel MW(wet):  lb/lb-mole  
 Dilution Tunnel H2O:  %  
 Dilution Tunnel Static:  In H2O  
 Tunnel Area:  ft<sup>2</sup>  
 Pitot Tube Cp:

Dilution Tunnel Traverse Data								
	Pt.1	Pt.2	Pt.3	Pt.4	Pt.5	Pt.6	Pt.7	Pt.8
dP	0.038	0.044	0.042	0.040	0.041	0.044	0.042	0.041
Temperature	110	110	110	110	110	110	110	110

0.042  
110.000

Tunnel Velocity:  ft/sec.  
 Intial Tunnel Flow:  scfm  
 Average Tunnel Flow:  scfm

JOB #	032-S-048-6 B																		
TECHNICIAN	GEN																		
DATE:	8_12_16											ROOM TEMP (F)	76.7	BEG	MID	END	AVG		
RUN #:	4											BAROMETRIC		29.99	29.99	29.99	29.99		
READING INTERVAL:	10																		
SAMPLE BOX :	A	METER Y FACTOR:	1.002											PROBE MATERIAL:	SS				
FRONT FILTER #:	2872&2877											REAR FILTER #:	2873						
FINAL LEAK RATE (CFM)	<0.01	@	5	IN-HG											FINAL LEAK RATE (CFM)	<0.01	@	5	IN-HG
Run Time:	90											AMBIENT FILTER #:		VOLUME	LITERS	FUEL MOISTURE DB	20.4	%	
TEST START TIME:	9:40											FINAL LEAK RATE (CFM):	@	IN-HG					
										TEMPERATURES									
ET	GAS METER VOLUME	SAMPLE RATE(FT3/MIN)	TUNNEL DELTA P	ORIFICE DELTA H	FILTER VAC	TUNNEL VEL FT/SEC	Proportional Rate (%)	Scale Weight	Weight Chg	TUNNEL TEMP	FLUE TEMP	FILTER TEMP	FB REAR TEMP	FB INT	METER TEMP	AMBIENT TEMP			
0	0.000	0.000	0.042	0.01	-0.06	14.664	NA	8.9	0	103	323	79	133	4167.79	77	75			
10	1.368	0.137	0.042	2	-0.76	14.664	102	7	1.9	161	775	86	154	4168.2	78	75			
20	2.756	0.139	0.042	2.01	-1.71	14.687	104	4.4	2.6	163	750	86	159	4168.58	81	76			
30	4.149	0.139	0.042	2.01	-1.41	14.628	103	2.5	1.9	158	731	86	142	4169.07	85	76			
40	5.545	0.140	0.042	2	-1.28	14.474	101	1.4	1.1	145	618	85	141	4169.65	88	77			
50	6.950	0.141	0.042	2.01	-1.93	14.269	100	0.9	0.5	128	491	83	140	4170.26	91	77			
60	8.362	0.141	0.042	2.02	-1.84	14.147	99	0.6	0.3	118	422	83	137	4170.97	94	77			
70	9.782	0.142	0.042	2.02	-1.48	14.086	99	0.4	0.2	113	388	85	132	4171.62	96	78			
80	11.202	0.142	0.042	2.02	-1.29	14.036	98	0.2	0.2	109	356	85	128	4172.34	98	78			
90	12.620	0.142	0.042	2.03	-0.73	13.987	97	0	0.2	105	331	85	125	4172.97	99	78			



TEST START TIME:		9:40								1	2	3	4	5	6	
										TEMPERATURES						
	GAS METER	SAMPLE	TUNNEL	ORIFICE	FILTER	TUNNEL VEL	Proportional	Scale	Weight	TUNNEL	FLUE	FILTER	FB REAR	FB	METER	AMBIENT
ET	VOLUME	RATE(FT3/MIN)	DELTA P	DELTA H	VAC	FT/SEC	Rate (%)	Weight	Chg	TEMP	TEMP	TEMP	TEMP	INT	TEMP	TEMP
	12.620		0.042	2.01		14.331	100.4			130	519				89	77







ET	GAS METER VOLUME	SAMPLE RATE(FT3/MIN)	PROPORTIONAL RATE	FLUE DRAFT	ORIFICE DELTA H	FILTER VAC	1	2	3	4	5	6	METER	STOVE AVG T		
							TEMPERATURES								FB	FB
							LEFT SIDE	RIGHT SIDE	FILTER	TOP	BOT					
	12.471	0.139	100.405	-0.058	1.98333	1.849	446	439	84	301	148	88	#N/A			

TOTAL      AVG      AVG      AVG      AVG      AVG      AVG      AVG      AVG      AVG      AVG      AVG      AVG

**DT**

#N/A

# Ambient Sample Results:

JOB NUMBER: 032-S-048-6 B  
 TECHNICIAN: GEN  
 DATE: 8\_12\_16  
 RUN NUMBER: 4

METER Y FACTOR: 1.003

	<u>Sample Volume (L)</u>	<u>Meter Temp °F</u>	<u>ΔH</u>	<u>ΔP</u>
Start	0	90	0	0
End	501.49	96	0	0

SAMPLE INFORMATION	
Total Sample Volume - Vm	501.490 Liters
Total Sample Volume - Vm	17.710 ft <sup>3</sup>
Average Sample Rate	0.20 ft <sup>3</sup> /min
Sample Time	90.00 Minutes
Average Meter Temperature	93 °F
Total Sample Volume (Standard Conditions) - Vmstd	17.000 dscf
Total Particulates	<span style="border: 1px solid black; padding: 2px;">0.2</span> mg
Particulate Concentration (dry-standard)	<span style="border: 1px solid black; padding: 2px;">0.000011765</span> grams/dscf
Particulate Emission Rate	<span style="border: 1px solid black; padding: 2px;">0.000133333</span> grams/hour

JOB NUMBER 032-S-048-6 B

RUN # 4  
 DATE: 8\_12\_16

BURN RATE 2.24 KG/HR DRY

FILTER A PARTICULATE 3.7 mg

FILTER B PARTICULATE 2.9 mg

Total Sample Volume - Vm  
 Average Gas Velocity in Dilution Tunnel - vs  
 Average Gas Flow Rate in Dilution Tunnel - Qsd  
 Total Sample Volume (Standard Conditions) - Vmstd

Average Tunnel Temperature  
 Average Delta p

Average Gas Meter Temperature  
 Average Delta H  
 Total Time of Test

Total Particulates

Particulate Concentration (dry-standard)  
**Ambient Train (dry-standard)**  
**Net (dry-standard)**

Particulate Emission Rate  
 Total PM Emissions

Average Total PM Emissions  
 AVERAGE PARTICULATE  
 EMISSIONS RATE

% OF AVERAGE

Emissions Factor

	SAMPLE A INFORMATION		SAMPLE B INFORMATION	
	12.62		12.47	
	14.35	feet/second	14.35	feet/second
	8888.44	dscf/hour	8888.44	dscf/hour
	12.26	dscf	12.11	dscf
	130.3	F	130.3	F
	0.042		0.042	
	89	F	88	F
	2.01	in-h20	1.98	in-h20
	90	min	90	min
	3.7	mg	2.9	mg
	0.00030	grams/dscf	0.00024	grams/dscf
	0.000011765	grams/dscf	0.000011765	grams/dscf
	0.000290107	grams/dscf	0.00022761	grams/dscf
	2.58	grams/hour	2.02	grams/hour
	3.87	grams	3.03	grams
			3.45	grams
			2.30	grams/hour
	112.1		87.9	
	1.154	g/Kg -Dry	0.905	g/Kg -Dry

**PREBURN**

JOB # 037\_S\_048\_6  
 TECHNICIAN IGENBTN  
 DATE: 8\_16\_16  
 RUN #: 5  
 READING INTERVAL: 10

Model Designation BUCK\_21NC

Tunnel Traverse Information									
	Pt.1	Pt.2	Pt.3	Pt.4	Pt.5	Pt.6	Pt.7	Pt.8	
dP	0.040	0.038	0.036	0.036	0.044	0.042	0.045	0.038	0.040
Temperature	100	100	100	100	100	100	100	100	100.000

Run Time: 70

ET	SCALE READING	FLUE DRAFT	TEMPERATURES					STOVE AVG T
			1	2	3	4	5	
			LEFT SIDE	RIGHT SIDE	BACK	TOP	BOTTOM	
0	5.9	-0.074	460	466	219	491	192	365.6
10	4.8	-0.06	465	483	227	479	209	372.6
20	4.1	-0.057	465	478	227	460	213	368.6
30	3.3	-0.052	462	467	223	446	212	362
40	2.8	-0.045	453	463	220	420	210	353.2
50	2.6	-0.039	433	451	214	376	202	335.2
60	2.4	-0.031	417	429	208	333	215	320.4
70	2.3	-0.031	400	406	201	299	219	305

Dilution Tunnel MW(dry):	29.00	lb/lb-mole
Dilution Tunnel MW(wet):	28.78	lb/lb-mole
Dilution Tunnel H2O:	2.00	%
Dilution Tunnel Static:	-0.400	In H2O
Tunnel Area:	0.196	ft <sup>2</sup>
Pitot Tube Cp:	0.99	

Tunnel Velocity: 13.59761 ft/sec.  
 Initial Tunnel Flow: 148.2731 scfm  
 Average Tunnel Flow: 148.9064 scfm

Notes:

			1	2	3	4	5											
			TEMPERATURES															
ET	SCALE READING	FLUE DRAFT	LEFT SIDE	RIGHT SIDE	BACK	TOP	BOTTOM	STOVE AVG T										
			444.375		217.375													

Run # 

5
---

  
 Date: 

8/16/16
---------

Dilution Tunnel MW(dry): 

29.00
-------

 lb/lb-mole  
 Dilution Tunnel MW(wet): 

28.78
-------

 lb/lb-mole  
 Dilution Tunnel H2O: 

2.00
------

 %  
 Dilution Tunnel Static: 

-0.400
--------

 In H2O  
 Tunnel Area: 

0.196
-------

 ft<sup>2</sup>  
 Pitot Tube Cp: 

0.99
------

Dilution Tunnel Traverse Data								
	Pt.1	Pt.2	Pt.3	Pt.4	Pt.5	Pt.6	Pt.7	Pt.8
dP	0.040	0.038	0.036	0.036	0.044	0.042	0.045	0.038
Temperature	100	100	100	100	100	100	100	100

0.040  
100.000

Tunnel Velocity: 

13.598
--------

 ft/sec.  
 Intial Tunnel Flow: 

148.27
--------

 scfm  
 Average Tunnel Flow: 

148.91
--------

 scfm

JOB #	037_S_048_6																	
TECHNICIAN	GENBTN																	
DATE:	8_16_16											ROOM TEMP (F)	79.8	BEG	MID	END	AVG	
RUN #:	5											BAROMETRIC		30.07	30.07	30.07	30.07	
READING INTERVAL:	10																	
SAMPLE BOX :	A	METER Y FACTOR:	1.001											PROBE MATERIAL:	SS			
FRONT FILTER #:	2878&2883				REAR FILTER #:	2879												
FINAL LEAK RATE (CFM):	<0.01	@	5	IN-HG	FINAL LEAK RATE (CFM):	<0.01	@	5	IN-HG									
Run Time:	210	AMBIENT FILTER #:			2882	VOLUME	1168.945	LITERS	FUEL MOISTURE DB			19.2	%					
TEST START TIME:	15:07	FINAL LEAK RATE (CFM):			<0.01	@	5	IN-HG	1	2	3	4	5	6				
TEMPERATURES																		
	GAS METER	SAMPLE	TUNNEL	ORIFICE	FILTER	TUNNEL VEL	Proportional	Scale	Weight	TUNNEL	FLUE	FILTER	FB REAR	FB	METER	AMBIENT		
ET	VOLUME	RATE(FT3/MIN)	DELTA P	DELTA H	VAC	FT/SEC	Rate (%)	Weight	Chg	TEMP	TEMP	TEMP	TEMP	INT	TEMP	TEMP		
0	0.000	0.000	0.04	0.01	-0.11		NA	9.2	0	94	251	79	200	4169.99	78	77		
10	1.380	0.138	0.04	2.01	-0.69	13.547	101	8.3	0.9	98	296	82	194	4170.64	79	77		
20	2.768	0.139	0.04	2	-0.94	13.486	100	7.8	0.5	93	243	82	186	4171.22	83	78		
30	4.163	0.140	0.04	2.01	-0.75	13.583	101	6.6	1.2	101	403	83	181	4171.68	86	78		
40	5.570	0.141	0.04	2.03	-1.33	13.644	101	5.3	1.3	106	465	84	183	4172.24	90	78		
50	6.982	0.141	0.04	2.04	-1.37	13.692	102	3.9	1.4	110	496	85	192	4172.81	93	79		
60	8.401	0.142	0.04	2.04	-1.33	13.704	102	2.7	1.2	111	479	86	205	4173.46	95	79		
70	9.820	0.142	0.04	2.04	-1.39	13.644	101	2	0.7	106	408	86	211	4174.05	98	80		
80	11.248	0.143	0.04	2.04	-0.59	13.608	101	1.7	0.3	103	347	86	211	4174.68	100	80		
90	12.680	0.143	0.04	2.04	-0.78	13.571	101	1.5	0.2	100	303	86	206	4175.26	101	80		
100	14.109	0.143	0.04	2.05	-1.45	13.547	100	1.4	0.1	98	280	85	199	4175.8	103	80		
110	15.544	0.144	0.04	2.04	-1.15	13.535	100	1.2	0.2	97	268	85	194	4176.29	104	80		
120	16.981	0.144	0.04	2.03	-1.3	13.523	100	1.1	0.1	96	253	85	190	4176.78	105	81		
130	18.418	0.144	0.04	2.04	-0.77	13.498	100	0.9	0.2	94	242	84	187	4177.24	105	80		
140	19.858	0.144	0.04	2.06	-1.1	13.511	100	0.8	0.1	95	235	84	184	4177.7	106	81		
150	21.299	0.144	0.04	2.03	-1.15	13.498	100	0.7	0.1	94	232	84	182	4178.06	107	81		
160	22.741	0.144	0.04	2.02	-1.03	13.498	100	0.5	0.2	94	226	84	180	4178.47	107	81		
170	24.182	0.144	0.04	2.05	-1.14	13.486	99	0.4	0.1	93	220	84	179	4178.79	108	81		
180	25.626	0.144	0.04	2.06	-1.46	13.486	100	0.3	0.1	93	216	84	176	4179.13	108	81		
190	27.072	0.145	0.04	2.05	-1.48	13.486	100	0.2	0.1	93	212	84	174	4179.47	108	81		
200	28.518	0.145	0.04	2.05	-0.87	13.486	100	0.1	0.1	93	208	84	172	4179.81	109	81		
210	29.963	0.145	0.04	2.07	-1.28	13.474	99	0	0.1	92	203	84	170	4180.08	109	81		

TEST START TIME:		15:07								1	2	3	4	5	6	
		TEMPERATURES														
ET	GAS METER VOLUME	SAMPLE RATE(FT3/MIN)	TUNNEL DELTA P	ORIFICE DELTA H	FILTER VAC	TUNNEL VEL FT/SEC	Proportional Rate (%)	Scale Weight	Weight Chg	TUNNEL TEMP	FLUE TEMP	FILTER TEMP	FB REAR TEMP	FB INT	METER TEMP	AMBIENT TEMP



TEST START TIME:		15:07								1	2	3	4	5	6	
										TEMPERATURES						
	GAS METER	SAMPLE	TUNNEL	ORIFICE	FILTER	TUNNEL VEL	Proportional	Scale	Weight	TUNNEL	FLUE	FILTER	FB REAR	FB	METER	AMBIENT
ET	VOLUME	RATE(FT3/MIN)	DELTA P	DELTA H	VAC	FT/SEC	Rate (%)	Weight	Chg	TEMP	TEMP	TEMP	TEMP	INT	TEMP	TEMP
	29.963		0.040	2.04		13.548	100.2			98	295				99	80

JOB #	037_S_048_6								
TECHNICIAN	GENBTN								
DATE:	8_16_16								
RUN #:	5								
READING INTERVAL:	10								
SAMPLE BOX :	B	METER Y FACTOR:	1.002	PROBE MATERIAL:	SS				
FRONT FILTER #:	2880			REAR FILTER #:	2881				
FINAL LEAK RATE (CFM):	<0.01	@	5	IN-HG	FINAL LEAK RATE (CFM):	<0.01	@	5	IN-HG

Run Time: **210** Firebox Delta T **50.8**

ET	GAS METER VOLUME	SAMPLE RATE(FT3/MIN)	PROPORTIONAL RATE	FLUE DRAFT	ORIFICE DELTA H	FILTER VAC	TEMPERATURES						STOVE AVG T
							1	2	3	4	5	6	
0	0	0	NA	0	0	1	392	404	80	294	188	77	296
10	1.364	0.136	101	-0.04	1.99	1.4	358	371	83	290	194	79	281
20	2.738	0.137	101	-0.03	1.96	1.57	316	334	82	266	203	82	261
30	4.111	0.137	101	-0.05	1.95	1.35	310	334	83	291	184	85	260
40	5.504	0.139	102	-0.06	2.01	1.81	332	360	84	383	179	89	287
50	6.901	0.140	102	-0.06	2	1.36	363	389	85	478	180	92	320
60	8.302	0.140	102	-0.06	1.99	1.72	392	420	86	537	171	94	345
70	9.703	0.140	101	-0.05	1.99	1.64	419	432	86	522	170	97	351
80	11.108	0.141	101	-0.05	1.98	1.86	426	427	86	463	176	99	341
90	12.519	0.141	101	-0.04	1.98	1.97	414	422	86	395	182	100	324
100	13.928	0.141	100	-0.03	2	1.82	403	415	85	347	179	102	309
110	15.343	0.142	100	-0.03	1.99	2.01	399	406	85	317	182	103	300
120	16.758	0.142	100	-0.04	1.98	1.3	393	397	85	293	184	104	291
130	18.174	0.142	100	-0.03	1.99	1.35	383	386	85	276	181	105	283
140	19.591	0.142	100	-0.03	1.98	1.85	376	376	85	263	179	106	276
150	21.008	0.142	99	-0.02	1.98	1.37	370	366	84	252	181	106	270
160	22.427	0.142	99	-0.03	1.98	1.53	367	360	84	246	178	107	266
170	23.847	0.142	99	-0.02	1.98	1.62	360	354	84	241	179	107	263
180	25.266	0.142	99	-0.03	1.96	1.73	353	346	84	235	173	108	257
190	26.687	0.142	99	-0.02	1.98	1.98	343	341	84	229	175	108	252
200	28.106	0.142	99	-0.02	1.99	2.06	335	335	84	225	177	109	249
210	29.528	0.142	99	-0.02	1.99	2.12	327	328	84	221	178	109	245

							1	2	3	4	5	6		
							TEMPERATURES							
ET	GAS METER VOLUME	SAMPLE RATE(FT3/MIN)	PROPORTIONAL RATE	FLUE DRAFT	ORIFICE DELTA H	FILTER VAC	LEFT SIDE	RIGHT SIDE	FILTER	FB TOP	FB BOT	METER	STOVE AVG T	

							1	2	3	4	5	6		
							TEMPERATURES							
ET	GAS METER VOLUME	SAMPLE RATE(FT3/MIN)	PROPORTIONAL RATE	FLUE DRAFT	ORIFICE DELTA H	FILTER VAC	LEFT SIDE	RIGHT SIDE	FILTER	FB TOP	FB BOT	METER	STOVE AVG T	
	29.528	0.141	100.222	-0.035	1.983333	1.655455	370	377	84	321	181	99	51	
	TOTAL	AVG	AVG	AVG	AVG	AVG	AVG	AVG	AVG	AVG	AVG	AVG	<b>DT</b>	

244.8

# Ambient Sample Results:

JOB NUMBER: 037\_S\_048\_6  
 TECHNICIAN: GENBTN  
 DATE: 8\_16\_16  
 RUN NUMBER: 5

METER Y FACTOR: 1.003

	<u>Sample Volume (L)</u>	<u>Meter Temp °F</u>	<u>ΔH</u>	<u>ΔP</u>
Start	0	81	0	0
End	1168.945	106	0	0

SAMPLE INFORMATION	
Total Sample Volume - Vm	1168.945 Liters
Total Sample Volume - Vm	41.281 ft <sup>3</sup>
Average Sample Rate	0.20 ft <sup>3</sup> /min
Sample Time	210.00 Minutes
Average Meter Temperature	93.5 °F
Total Sample Volume (Standard Conditions) - Vmstd	39.695 dscf
Total Particulates	<span style="border: 1px solid black; padding: 2px;">0.3</span> mg
Particulate Concentration (dry-standard)	<span style="border: 1px solid black; padding: 2px;">0.000007558</span> grams/dscf
Particulate Emission Rate	<span style="border: 1px solid black; padding: 2px;">0.000085714</span> grams/hour

JOB NUMBER 037\_S\_048\_6

RUN # 5  
 DATE: 8\_16\_16

BURN RATE 1.00 KG/HR DRY

FILTER A PARTICULATE 8.9 mg

FILTER B PARTICULATE 7.6 mg

Total Sample Volume - Vm  
 Average Gas Velocity in Dilution Tunnel - vs  
 Average Gas Flow Rate in Dilution Tunnel - Qsd  
 Total Sample Volume (Standard Conditions) - Vmstd

Average Tunnel Temperature  
 Average Delta p

Average Gas Meter Temperature  
 Average Delta H  
 Total Time of Test

Total Particulates

Particulate Concentration (dry-standard)  
**Ambient Train (dry-standard)**  
**Net (dry-standard)**

Particulate Emission Rate  
 Total PM Emissions

Average Total PM Emissions  
 AVERAGE PARTICULATE  
 EMISSIONS RATE

% OF AVERAGE

Emissions Factor

	SAMPLE A INFORMATION		SAMPLE B INFORMATION	
	29.96		29.53	
	13.60	feet/second	13.60	feet/second
	8934.38	dscf/hour	8934.38	dscf/hour
	28.60	dscf	28.25	dscf
	97.9	F	97.9	F
	0.040		0.040	
	99	F	99	F
	2.04	in-h20	1.98	in-h20
	210	min	210	min
	8.9	mg	7.6	mg
	0.00031	grams/dscf	0.00027	grams/dscf
	0.000007558	grams/dscf	0.000007558	grams/dscf
	0.000303585	grams/dscf	0.000261511	grams/dscf
	2.71	grams/hour	2.34	grams/hour
	9.49	grams	8.18	grams
			8.84	grams
			2.52	grams/hour
	107.4		92.6	
	2.712	g/Kg -Dry	2.336	g/Kg -Dry

## EPA Method 28 - Weighted Average



Weighted Average: 1.7 (g/hr)

Client: New Buck Corporation  
Model: 21NC  
Tracking No.: 48  
Project No.: 037-S-048-6B  
Test Dates: 8/9/16 - 8/16/16

Burn Rate Category	1
Burn Rate (kg/hr-dry)	0.77
Emissions Rate (g/hr)	1.0
Emissions Rate Cap (g/hr)	15
Weighting Factor	21.24%
Run Number	1

Burn Rate Category	2
Burn Rate (kg/hr-dry)	0.99
Emissions Rate (g/hr)	1.9
Emissions Rate Cap (g/hr)	15
Weighting Factor	26.15%
Run Number	2

Burn Rate Category	3
Burn Rate (kg/hr-dry)	1.35
Emissions Rate (g/hr)	1.7
Emissions Rate Cap (g/hr)	15
Weighting Factor	32.73%
Run Number	3

Burn Rate Category	4
Burn Rate (kg/hr-dry)	2.24
Emissions Rate (g/hr)	2.3
Emissions Rate Cap (g/hr)	18
Weighting Factor	19.88%
Run Number	4

## EPA Method 28 - Weighted Average



Client: New Buck Corporation  
Model: 21NC  
Tracking No.: 48  
Project No.: 037-S-048-6B  
Test Dates: 8/9/16 - 8/16/16

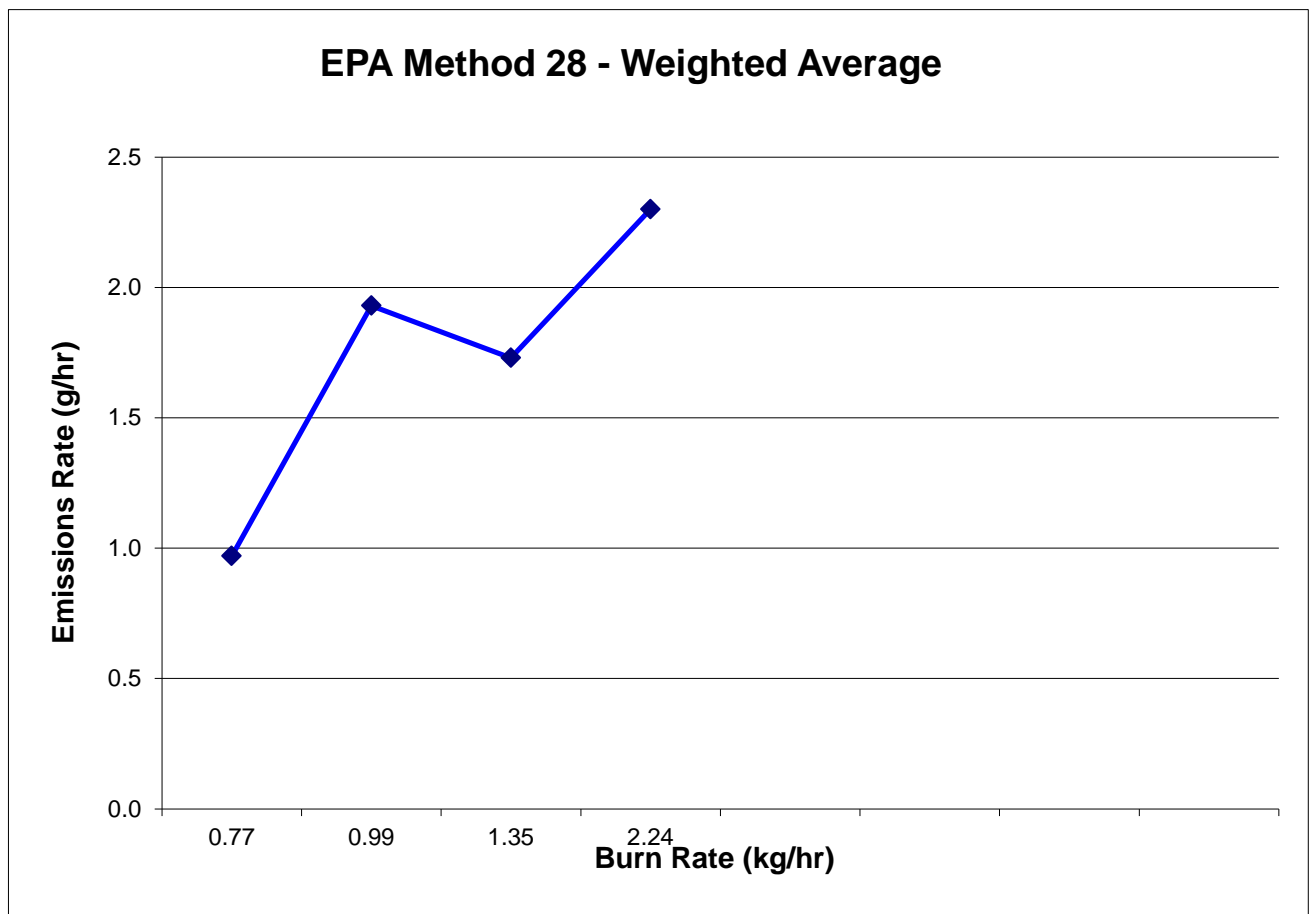







Run # 

1
---

  
 Date: 

8/9/16
--------

Dilution Tunnel MW(dry): 

29.00
-------

 lb/lb-mole  
 Dilution Tunnel MW(wet): 

28.78
-------

 lb/lb-mole  
 Dilution Tunnel H2O: 

2.00
------

 %  
 Dilution Tunnel Static: 

-0.400
--------

 In H2O  
 Tunnel Area: 

0.196
-------

 ft<sup>2</sup>  
 Pitot Tube Cp: 

0.99
------

Dilution Tunnel Traverse Data								
	Pt.1	Pt.2	Pt.3	Pt.4	Pt.5	Pt.6	Pt.7	Pt.8
dP	0.040	0.040	0.042	0.040	0.038	0.041	0.042	0.042
Temperature	95	95	95	95	95	95	95	95

0.041  
95.000

Tunnel Velocity: 

13.777
--------

 ft/sec.  
 Intial Tunnel Flow: 

150.34
--------

 scfm  
 Average Tunnel Flow: 

150.64
--------

 scfm

JOB #	037-S-048-6_1_Hour																		
TECHNICIAN	GEN										ROOM TEMP (F)	75.0		BEG	MID	END	AVG		
DATE:	8_9_16												BAROMETRIC	30.03		30.03	30.03	30.03	30.03
RUN #:	1																		
READING INTERVAL:	10																		
SAMPLE BOX :	A		METER Y FACTOR:	1.002												PROBE MATERIAL:	SS		
FRONT FILTER #:	2854&2859		REAR FILTER #:			2855													
FINAL LEAK RATE (CFM):	<0.01		@	5		IN-HG	FINAL LEAK RATE (CFM)		<0.01		@	5		IN-HG					
Run Time:	60		AMBIENT FILTER #:			2858		VOLUME	1509.6		LITERS	FUEL MOISTURE DB		20.9		%			
			FINAL LEAK RATE (CFM):			<0.01		@	5		IN-HG								
TEST START TIME:	9:52																		
											TEMPERATURES								
	GAS METER	SAMPLE	TUNNEL	ORIFICE	FILTER	TUNNEL VEL	Proportional	Scale	Weight	TUNNEL	FLUE	FILTER	FB REAR	FB	METER	AMBIENT			
ET	VOLUME	RATE(FT3/MIN)	DELTA P	DELTA H	VAC	FT/SEC	Rate (%)	Weight	Chg	TEMP	TEMP	TEMP	TEMP	INT	TEMP	TEMP			
0	0.000	0.000	0.041	0.01	-0.11		NA	9.2	0	85	196	75	142	4167.94	78	71			
10	1.383	0.138	0.041	2.01	-0.77	13.774	101	8	1.2	102	393	78	153	4167.39	79	72			
20	2.767	0.138	0.041	1.98	-1.35	13.774	100	6.7	1.3	102	420	79	162	4167.04	82	71			
30	4.163	0.140	0.041	2	-0.67	13.749	101	5.4	1.3	100	418	78	134	4166.7	85	71			
40	5.563	0.140	0.041	2.02	-1	13.761	100	4.1	1.3	101	437	79	129	4166.75	88	73			
50	6.966	0.140	0.041	2.03	-1.49	13.749	100	3.1	1	100	404	80	130	4167.31	90	74			
60	8.378	0.141	0.041	2.01	-0.96	13.700	100	2.4	0.7	96	339	80	128	4167.86	93	75			



TEST START TIME:		9:52								1	2	3	4	5	6	
										TEMPERATURES						
	GAS METER	SAMPLE	TUNNEL	ORIFICE	FILTER	TUNNEL VEL	Proportional	Scale	Weight	TUNNEL	FLUE	FILTER	FB REAR	FB	METER	AMBIENT
ET	VOLUME	RATE(FT3/MIN)	DELTA P	DELTA H	VAC	FT/SEC	Rate (%)	Weight	Chg	TEMP	TEMP	TEMP	TEMP	INT	TEMP	TEMP
	8.378		0.041	2.01		13.751	100.4			98	372				85	72

JOB #	037-S-048-6_1_Hour								
TECHNICIAN	GEN								
DATE:	8_9_16								
RUN #:	1								
READING INTERVAL:	10								
SAMPLE BOX :	B	METER Y FACTOR:	1.001	PROBE MATERIAL:	SS				
FRONT FILTER #:	2856			REAR FILTER #:	2867				
FINAL LEAK RATE (CFM):	<0.01	@	5	IN-HG	FINAL LEAK RATE (CFM):	<0.01	@	5	IN-HG

Run Time: **270** Firebox Delta T **83.75**

ET	GAS METER VOLUME	SAMPLE RATE(FT3/MIN)	PROPORTIONAL RATE	FLUE DRAFT	ORIFICE DELTA H	FILTER VAC	1	2	3	4	5	6	METER	STOVE AVG T
							TEMPERATURES							
							LEFT SIDE	RIGHT SIDE	FILTER	FB TOP	FB BOT			
0	0	0	NA	0	0	1	367	376	75	225	165	78	255	
10	1.368	0.137	102	-0.05	1.96	1.37	335	339	78	256	147	79	246	
20	2.737	0.137	102	-0.06	1.96	1.35	325	335	78	308	155	81	257	
30	4.110	0.137	101	-0.06	1.97	1.75	340	344	78	317	153	84	258	
40	5.488	0.138	101	-0.06	1.98	2.02	356	357	79	337	149	87	266	
50	6.877	0.139	101	-0.05	1.98	1.74	373	376	80	358	146	90	277	
60	8.268	0.139	101	-0.04	1.97	1.31	386	384	81	338	145	92	276	
70	9.659	0.139	#DIV/0!	-0.03	1.96	1.39	381	373	80	284	143	95	295	
80	11.055	0.140	#DIV/0!	-0.03	1.97	1.54	368	357	80	244	141	97	278	
90	12.456	0.140	#DIV/0!	-0.02	1.97	1.6	360	342	80	214	141	98	264	
100	13.857	0.140	#DIV/0!	-0.02	1.96	1.92	352	329	79	191	141	100	253	
110	15.259	0.140	#DIV/0!	-0.02	1.98	1.69	348	318	79	177	140	101	246	
120	16.666	0.141	#DIV/0!	-0.01	1.97	1.63	342	309	79	168	139	102	240	
130	18.072	0.141	#DIV/0!	-0.01	1.97	1.89	334	300	79	164	139	103	234	
140	19.478	0.141	#DIV/0!	-0.01	1.99	1.26	327	292	79	161	139	103	230	
150	20.890	0.141	#DIV/0!	-0.01	1.97	1.68	322	284	78	159	139	104	226	
160	22.297	0.141	#DIV/0!	-0.01	1.97	1.55	318	275	78	156	138	104	222	
170	23.708	0.141	#DIV/0!	-0.01	1.98	1.96	312	267	78	153	137	105	217	
180	25.117	0.141	#DIV/0!	-0.01	1.97	1.78	305	260	78	150	135	105	213	
190	26.526	0.141	#DIV/0!	0	1.96	1.96	295	252	78	147	134	106	207	
200	27.938	0.141	#DIV/0!	-0.01	1.96	1.94	285	243	78	143	134	106	201	
210	29.349	0.141	#DIV/0!	-0.01	1.95	1.72	274	233	78	139	132	106	195	
220	30.762	0.141	#DIV/0!	-0.01	1.96	1.4	268	223	78	136	131	106	190	





							1	2	3	4	5	6		
							TEMPERATURES							
ET	GAS METER VOLUME	SAMPLE RATE(FT3/MIN)	PROPORTIONAL RATE	FLUE DRAFT	ORIFICE DELTA H	FILTER VAC	LEFT SIDE	RIGHT SIDE	FILTER	FB TOP	FB BOT	METER	STOVE AVG T	
	37.82	0.140	#DIV/0!	-0.020	1.96963	1.638929	319	293	79	199	139	99	84	
	TOTAL	AVG	AVG	AVG	AVG	AVG	AVG	AVG	AVG	AVG	AVG	AVG	<b>DT</b>	

171.25

# Ambient Sample Results:

JOB NUMBER: 037-S-048-6\_1\_Hour  
 TECHNICIAN: GEN  
 DATE: 8\_9\_16  
 RUN NUMBER: 1

METER Y FACTOR: 1.003

	<u>Sample Volume (L)</u>	<u>Meter Temp °F</u>	<u>ΔH</u>	<u>ΔP</u>
Start	0	84	0	0
End	1509.6	96	0	0

SAMPLE INFORMATION	
Total Sample Volume - Vm	1509.600 Liters
Total Sample Volume - Vm	53.311 ft <sup>3</sup>
Average Sample Rate	0.89 ft <sup>3</sup> /min
Sample Time	60.00 Minutes
Average Meter Temperature	90 °F
Total Sample Volume (Standard Conditions) - Vmstd	51.521 dscf
Total Particulates	<span style="border: 1px solid black; padding: 2px;">0.3</span> mg
Particulate Concentration (dry-standard)	<span style="border: 1px solid black; padding: 2px;">0.000005823</span> grams/dscf
Particulate Emission Rate	<span style="border: 1px solid black; padding: 2px;">0.000300000</span> grams/hour

JOB NUMBER 037-S-048-6\_1\_Hour

RUN # 1  
 DATE: 8\_9\_16

BURN RATE 3.45 KG/HR DRY

FILTER A PARTICULATE 3.5 mg

FILTER B PARTICULATE  mg

Total Sample Volume - Vm  
 Average Gas Velocity in Dilution Tunnel - vs  
 Average Gas Flow Rate in Dilution Tunnel - Qsd  
 Total Sample Volume (Standard Conditions) - Vmstd

Average Tunnel Temperature  
 Average Delta p

Average Gas Meter Temperature  
 Average Delta H  
 Total Time of Test

Total Particulates

Particulate Concentration (dry-standard)  
**Ambient Train (dry-standard)**  
**Net (dry-standard)**  
 Particulate Emission Rate  
 Total PM Emissions

Average Total PM Emissions  
 AVERAGE PARTICULATE  
 EMISSIONS RATE

% OF AVERAGE

Emissions Factor

SAMPLE A INFORMATION		SAMPLE B INFORMATION	
8.38			
13.78	feet/second		feet/second
9038.61	dscf/hour		dscf/hour
8.20	dscf		dscf
98.0	F		F
0.041			
85	F		F
2.01	in-h20		in-h20
60	min		min
3.5	mg		mg
0.00043	grams/dscf		grams/dscf
0.000005823	grams/dscf		grams/dscf
0.000420853	grams/dscf		grams/dscf
3.80	grams/hour		grams/hour
3.80	grams		grams
		3.80	grams
		1.90	grams/hour
200.0		0.0	
1.102	g/Kg -Dry	0.000	g/Kg -Dry

PREBURN

JOB # 037-S-048-6\_1\_Hour

Model Designation BUCK 21NC

TECHNICIAIGEN

DATE: 8\_10\_16

RUN #: 2

READING INTERVAL:

10

Tunnel Traverse Information									
	Pt.1	Pt.2	Pt.3	Pt.4	Pt.5	Pt.6	Pt.7	Pt.8	
dP	0.040	0.043	0.042	0.040	0.040	0.041	0.042	0.043	0.041
Temperature	95	95	95	95	95	95	95	95	95.000

Run Time:

70

ET	SCALE READING	FLUE DRAFT	TEMPERATURES					STOVE AVG T
			1	2	3	4	5	
			LEFT SIDE	RIGHT SIDE	BACK	TOP	BOTTOM	
0	5.8	-0.08	447	411	134	408	142	308.4
10	4.6	-0.067	478	447	140	416	151	326.4
20	3.7	-0.054	479	455	142	381	152	321.8
30	3.2	-0.05	457	459	145	324	161	309.2
40	3.1	-0.041	443	436	145	276	166	293.2
50	2.7	-0.034	429	413	145	241	171	279.8
60	2.6	-0.029	408	395	154	228	182	273.4
70	2.5	-0.025	377	360	140	202	176	251

Dilution Tunnel MW(dry): 29.00 lb/lb-mole  
 Dilution Tunnel MW(wet): 28.78 lb/lb-mole  
 Dilution Tunnel H2O: 2.00 %  
 Dilution Tunnel Static: -0.400 In H2O  
 Tunnel Area: 0.196 ft<sup>2</sup>  
 Pitot Tube Cp: 0.99

Tunnel Velocity: 13.84313 ft/sec.  
 Intial Tunnel Flow: 151.7482 scfm  
 Average Tunnel Flow: 149.9221 scfm

Notes:

			1	2	3	4	5								
			TEMPERATURES												
ET	SCALE READING	FLUE DRAFT	LEFT SIDE	RIGHT SIDE	BACK	TOP	BOTTOM	STOVE AVG T							
			439.75		143.125										

Run # 

2
---

  
 Date: 

8/10/16
---------

Dilution Tunnel MW(dry): 

29.00
-------

 lb/lb-mole  
 Dilution Tunnel MW(wet): 

28.78
-------

 lb/lb-mole  
 Dilution Tunnel H2O: 

2.00
------

 %  
 Dilution Tunnel Static: 

-0.400
--------

 In H2O  
 Tunnel Area: 

0.196
-------

 ft<sup>2</sup>  
 Pitot Tube Cp: 

0.99
------

Dilution Tunnel Traverse Data								
	Pt.1	Pt.2	Pt.3	Pt.4	Pt.5	Pt.6	Pt.7	Pt.8
dP	0.040	0.043	0.042	0.040	0.040	0.041	0.042	0.043
Temperature	95	95	95	95	95	95	95	95

0.041  
95.000

Tunnel Velocity: 

13.843
--------

 ft/sec.  
 Intial Tunnel Flow: 

151.75
--------

 scfm  
 Average Tunnel Flow: 

149.92
--------

 scfm

JOB #	037-S-048-6_1_Hour																			
TECHNICIAN	GEN										ROOM TEMP (F)		77.3		BEG	MID	END	AVG		
DATE:	8_10_16												BAROMETRIC		30.04	30.04	30.04	30.04		
RUN #:	2																			
READING INTERVAL:	10																			
SAMPLE BOX :	A		METER Y FACTOR:		1.002												PROBE MATERIAL:		SS	
FRONT FILTER #:	2860&2865		REAR FILTER #:		2861															
FINAL LEAK RATE (CFM):	<0.01		@		5		IN-HG		FINAL LEAK RATE (CFM)		<0.01		@		5		IN-HG			
Run Time:	60		AMBIENT FILTER #:		2864		VOLUME		1235.09		LITERS		FUEL MOISTURE DB		19.7		%			
			FINAL LEAK RATE (CFM):		<0.01		@		5		IN-HG									
TEST START TIME:	9:30																			
										TEMPERATURES										
	GAS METER	SAMPLE	TUNNEL	ORIFICE	FILTER	TUNNEL VEL	Proportional	Scale	Weight	TUNNEL	FLUE	FILTER	FB REAR	FB	METER	AMBIENT				
ET	VOLUME	RATE(FT3/MIN)	DELTA P	DELTA H	VAC	FT/SEC	Rate (%)	Weight	Chg	TEMP	TEMP	TEMP	TEMP	INT	TEMP	TEMP				
0	0.000	0.000	0.041	0	-0.02		NA	9.6	0	89	210	76	141	4167.66	77	75				
10	1.377	0.138	0.041	1.99	-0.84	13.747	100	8.4	1.2	100	326	80	156	4168.15	79	75				
20	2.759	0.138	0.041	1.98	-1.34	13.808	100	7.3	1.1	105	497	82	155	4168.58	82	75				
30	4.139	0.138	0.041	1.96	-0.74	13.869	100	5.5	1.8	110	514	83	135	4169.05	85	76				
40	5.540	0.140	0.041	2.05	-0.88	13.893	101	3.9	1.6	112	518	84	134	4169.55	89	76				
50	6.952	0.141	0.041	2.03	-0.93	13.832	101	2.9	1	107	440	84	137	4170.11	92	77				
60	8.364	0.141	0.041	2.02	-0.86	13.771	100	2.2	0.7	102	381	84	138	4170.66	94	77				

TEST START TIME:		9:30								1	2	3	4	5	6	
										TEMPERATURES						
	GAS METER	SAMPLE	TUNNEL	ORIFICE	FILTER	TUNNEL VEL	Proportional	Scale	Weight	TUNNEL	FLUE	FILTER	FB REAR	FB	METER	AMBIENT
ET	VOLUME	RATE(FT3/MIN)	DELTA P	DELTA H	VAC	FT/SEC	Rate (%)	Weight	Chg	TEMP	TEMP	TEMP	TEMP	INT	TEMP	TEMP



TEST START TIME:		9:30								1	2	3	4	5	6	
										TEMPERATURES						
	GAS METER	SAMPLE	TUNNEL	ORIFICE	FILTER	TUNNEL VEL	Proportional	Scale	Weight	TUNNEL	FLUE	FILTER	FB REAR	FB	METER	AMBIENT
ET	VOLUME	RATE(FT3/MIN)	DELTA P	DELTA H	VAC	FT/SEC	Rate (%)	Weight	Chg	TEMP	TEMP	TEMP	TEMP	INT	TEMP	TEMP
	8.364		0.041	2.01		13.820	100.3			104	412				85	76

JOB #	037-S-048-6_1_Hour								
TECHNICIAN	GEN								
DATE:	8_10_16								
RUN #:	2								
READING INTERVAL:	10								
SAMPLE BOX :		METER Y FACTOR:	1.001	PROBE MATERIAL:		SS			
FRONT FILTER #:	2862			REAR FILTER #:	2863				
FINAL LEAK RATE (CFM):	<0.01	@	5	IN-HG	FINAL LEAK RATE (CFM):	<0.01	@	5	IN-HG

Run Time: **220** Firebox Delta T **48.05**

ET	GAS METER VOLUME	SAMPLE RATE (FT3/MIN)	PROPORTIONAL RATE	FLUE DRAFT	ORIFICE DELTA H	FILTER VAC	1	2	3	4	5	6	METER	STOVE AVG T
							TEMPERATURES							
							LEFT SIDE	RIGHT SIDE	FILTER	FB TOP	FB BOT			
0	0	0	NA	0	0	1	371	353	76	200	164	77	246	
10	1.366	0.137	101	-0.04	1.97	1.62	338	319	80	240	158	78	242	
20	2.734	0.137	101	-0.07	1.97	1.44	316	300	81	256	170	81	239	
30	4.099	0.137	100	-0.06	1.94	1.63	348	328	83	338	158	84	261	
40	5.476	0.138	101	-0.07	1.98	1.78	378	356	84	387	155	88	282	
50	6.860	0.138	100	-0.05	1.96	2.08	405	387	84	396	154	91	296	
60	8.249	0.139	100	-0.05	1.96	1.47	413	404	84	346	154	94	291	
70	9.648	0.140	#DIV/0!	-0.05	2.01	1.71	414	403	83	303	155	96	319	
80	11.057	0.141	#DIV/0!	-0.04	2.01	2.13	411	395	83	267	155	98	307	
90	12.473	0.142	#DIV/0!	-0.03	2.02	2.11	409	388	82	240	154	99	298	
100	13.887	0.141	#DIV/0!	-0.03	2	2.13	399	375	82	213	153	101	285	
110	15.306	0.142	#DIV/0!	-0.02	2.02	1.76	382	360	81	192	150	102	271	
120	16.723	0.142	#DIV/0!	-0.02	2.02	1.37	367	346	81	181	149	103	261	
130	18.145	0.142	#DIV/0!	-0.02	2.01	1.29	355	333	81	173	147	104	252	
140	19.563	0.142	#DIV/0!	-0.02	2.01	1.45	344	323	80	168	144	104	245	
150	20.986	0.142	#DIV/0!	-0.02	2.02	2.1	335	312	80	163	142	105	238	
160	22.407	0.142	#DIV/0!	-0.03	2	1.57	327	304	80	159	139	105	232	
170	23.831	0.142	#DIV/0!	-0.02	2.01	2.17	319	293	80	155	139	106	227	
180	25.254	0.142	#DIV/0!	-0.02	1.99	1.8	312	281	80	151	138	106	221	
190	26.676	0.142	#DIV/0!	-0.02	2.01	1.48	302	269	80	147	136	106	214	
200	28.101	0.143	#DIV/0!	-0.02	2	1.57	293	257	80	143	136	106	207	
210	29.525	0.142	#DIV/0!	-0.01	2	1.74	286	247	80	141	134	107	202	
220	30.952	0.143	#DIV/0!	-0.01	2	1.9	280	239	80	138	134	107	198	



							1	2	3	4	5	6		
							TEMPERATURES							
ET	GAS METER VOLUME	SAMPLE RATE(FT3/MIN)	PROPORTIONAL RATE	FLUE DRAFT	ORIFICE DELTA H	FILTER VAC	LEFT SIDE	RIGHT SIDE	FILTER	FB TOP	FB BOT	METER	STOVE AVG T	
	30.952	0.141	#DIV/0!	-0.031	1.995909	1.708696	352	329	81	222	149	98	48	
	TOTAL	AVG	AVG	AVG	AVG	AVG	AVG	AVG	AVG	AVG	AVG	AVG	<b>DT</b>	

197.75

# Ambient Sample Results:

JOB NUMBER: 037-S-048-6\_1\_Hour  
 TECHNICIAN: GEN  
 DATE: 8\_10\_16  
 RUN NUMBER: 2

METER Y FACTOR: 1.003

	<u>Sample Volume (L)</u>	<u>Meter Temp °F</u>	<u>ΔH</u>	<u>ΔP</u>
Start	0	90	0	0
End	1235.09	98	0	0

SAMPLE INFORMATION	
Total Sample Volume - Vm	1235.090 Liters
Total Sample Volume - Vm	43.617 ft <sup>3</sup>
Average Sample Rate	0.73 ft <sup>3</sup> /min
Sample Time	60.00 Minutes
Average Meter Temperature	94 °F
Total Sample Volume (Standard Conditions) - Vmstd	41.862 dscf
Total Particulates	<span style="border: 1px solid black; padding: 2px;">0.4</span> mg
Particulate Concentration (dry-standard)	<span style="border: 1px solid black; padding: 2px;">0.000009555</span> grams/dscf
Particulate Emission Rate	<span style="border: 1px solid black; padding: 2px;">0.000400000</span> grams/hour

JOB NUMBER 037-S-048-6\_1\_Hour

RUN # 2  
 DATE: 8\_10\_16

BURN RATE 3.64 KG/HR DRY

FILTER A PARTICULATE 6.0 mg

FILTER B PARTICULATE  mg

Total Sample Volume - Vm  
 Average Gas Velocity in Dilution Tunnel - vs  
 Average Gas Flow Rate in Dilution Tunnel - Qsd  
 Total Sample Volume (Standard Conditions) - Vmstd

Average Tunnel Temperature  
 Average Delta p

Average Gas Meter Temperature  
 Average Delta H  
 Total Time of Test

Total Particulates

Particulate Concentration (dry-standard)  
**Ambient Train (dry-standard)**  
**Net (dry-standard)**  
 Particulate Emission Rate  
 Total PM Emissions

Average Total PM Emissions  
 AVERAGE PARTICULATE  
 EMISSIONS RATE

% OF AVERAGE

Emissions Factor

SAMPLE A INFORMATION		SAMPLE B INFORMATION	
8.36			
13.84	feet/second		feet/second
8995.32	dscf/hour		dscf/hour
8.19	dscf		dscf
103.6	F		F
0.041			
85	F		F
2.01	in-h20		in-h20
60	min		min
6	mg		mg
0.00073	grams/dscf		grams/dscf
0.000009555	grams/dscf		grams/dscf
0.000723453	grams/dscf		grams/dscf
6.51	grams/hour		grams/hour
6.51	grams		grams
		6.51	grams
		3.25	grams/hour
200.0		0.0	
1.789	g/Kg -Dry	0.000	g/Kg -Dry

PREBURN

JOB # 037-S-048-6 B\_1\_Hour

Model Designation BUCK 21NC

TECHNICIAIGEN

DATE: 8\_11\_16

RUN #: 3

READING INTERVAL: 10

Run Time: 80

Tunnel Traverse Information									
	Pt.1	Pt.2	Pt.3	Pt.4	Pt.5	Pt.6	Pt.7	Pt.8	
dP	0.038	0.044	0.042	0.040	0.041	0.044	0.042	0.041	0.042
Temperature	110	110	110	110	110	110	110	110	110.000

ET	SCALE READING	FLUE DRAFT	TEMPERATURES					STOVE AVG T
			1	2	3	4	5	
			LEFT SIDE	RIGHT SIDE	BACK	TOP	BOTTOM	
0	6.5	-0.072	495	371	131	345	177	303.8
10	5.2	-0.067	514	387	134	342	178	311
20	4.2	-0.064	522	416	135	317	177	313.4
30	3.5	-0.057	502	437	135	294	177	309
40	3.1	-0.045	470	425	133	255	175	291.6
50	2.7	-0.048	443	404	135	231	150	272.6
60	2.5	-0.039	418	394	158	260	171	280.2
70	2.3	-0.032	392	380	149	234	193	269.6
80	2.2	-0.029	358	347	129	191	176	240.2

Dilution Tunnel MW(dry): 29.00 lb/lb-mole  
 Dilution Tunnel MW(wet): 28.78 lb/lb-mole  
 Dilution Tunnel H2O: 2.00 %  
 Dilution Tunnel Static: -0.400 In H2O  
 Tunnel Area: 0.196 ft<sup>2</sup>  
 Pitot Tube Cp: 0.99

Tunnel Velocity: 13.98605 ft/sec.  
 Initial Tunnel Flow: 149.9421 scfm  
 Average Tunnel Flow: 152.0093 scfm

Notes:





Run # 3  
 Date: 8/11/16

Dilution Tunnel MW(dry): 29.00 lb/lb-mole  
 Dilution Tunnel MW(wet): 28.78 lb/lb-mole  
 Dilution Tunnel H2O: 2.00 %  
 Dilution Tunnel Static: -0.400 In H2O  
 Tunnel Area: 0.196 ft<sup>2</sup>  
 Pitot Tube Cp: 0.99

Dilution Tunnel Traverse Data								
	Pt.1	Pt.2	Pt.3	Pt.4	Pt.5	Pt.6	Pt.7	Pt.8
dP	0.038	0.044	0.042	0.040	0.041	0.044	0.042	0.041
Temperature	110	110	110	110	110	110	110	110

0.042  
110.000

Tunnel Velocity: 13.986 ft/sec.  
 Intial Tunnel Flow: 149.94 scfm  
 Average Tunnel Flow 152.01 scfm

JOB #	037-S-048-6 B_1_Hour																			
TECHNICIAN	GEN										ROOM TEMP (F)		72.9		BEG	MID	END	AVG		
DATE:	8_11_16												BAROMETRIC		30.04	30.04	30.04	30.04		
RUN #:	3																			
READING INTERVAL:	10																			
SAMPLE BOX :	A		METER Y FACTOR:		1.002												PROBE MATERIAL:		SS	
FRONT FILTER #:	2866&2871												REAR FILTER #:		2867					
FINAL LEAK RATE (CFM):	<0.01		@		5		IN-HG		FINAL LEAK RATE (CFM)		<0.01		@		5		IN-HG			
Run Time:	60		AMBIENT FILTER #:		2870		VOLUME		843.53		LITERS		FUEL MOISTURE DB		21.3		%			
			FINAL LEAK RATE (CFM):		<0.01		@		5		IN-HG									
TEST START TIME:	10:02																			
										TEMPERATURES										
	GAS METER	SAMPLE	TUNNEL	ORIFICE	FILTER	TUNNEL VEL	Proportional	Scale	Weight	TUNNEL	FLUE	FILTER	FB REAR	FB	METER	AMBIENT				
ET	VOLUME	RATE(FT3/MIN)	DELTA P	DELTA H	VAC	FT/SEC	Rate (%)	Weight	Chg	TEMP	TEMP	TEMP	TEMP	INT	TEMP	TEMP				
0	0.000	0.000	0.042	0	-0.08		NA	9	0	83	202	73	126	4162.9	75	72				
10	1.373	0.137	0.042	2	-1.48	13.839	99	8.1	0.9	94	346	76	138	4162.95	76	71				
20	2.763	0.139	0.042	2.03	-0.86	14.000	101	6.3	1.8	107	500	79	147	4163.06	79	71				
30	4.158	0.140	0.042	2.03	-0.86	14.037	101	4.7	1.6	110	531	80	126	4163.14	82	72				
40	5.555	0.140	0.042	2	-1.37	14.062	101	3.1	1.6	112	545	80	125	4163.36	85	72				
50	6.961	0.141	0.042	2.01	-1.56	13.988	101	2.2	0.9	106	457	79	127	4163.65	88	73				
60	8.368	0.141	0.042	2.03	-1.53	13.901	100	1.6	0.6	99	378	79	127	4163.93	90	73				

TEST START TIME:		10:02								1	2	3	4	5	6	
		TEMPERATURES														
	GAS METER	SAMPLE	TUNNEL	ORIFICE	FILTER	TUNNEL VEL	Proportional	Scale	Weight	TUNNEL	FLUE	FILTER	FB REAR	FB	METER	AMBIENT
ET	VOLUME	RATE(FT3/MIN)	DELTA P	DELTA H	VAC	FT/SEC	Rate (%)	Weight	Chg	TEMP	TEMP	TEMP	TEMP	INT	TEMP	TEMP

TEST START TIME:		10:02								1	2	3	4	5	6	
										TEMPERATURES						
	GAS METER	SAMPLE	TUNNEL	ORIFICE	FILTER	TUNNEL VEL	Proportional	Scale	Weight	TUNNEL	FLUE	FILTER	FB REAR	FB	METER	AMBIENT
ET	VOLUME	RATE(FT3/MIN)	DELTA P	DELTA H	VAC	FT/SEC	Rate (%)	Weight	Chg	TEMP	TEMP	TEMP	TEMP	INT	TEMP	TEMP
	8.368		0.042	2.02		13.971	100.4			102	423				82	72

JOB #	037-S-048-6 B_1_Hour								
TECHNICIAN	GEN								
DATE:	8_11_16								
RUN #:	3								
READING INTERVAL:	10								
SAMPLE BOX :	B	METER Y FACTOR:	1.001	PROBE MATERIAL:	SS				
FRONT FILTER #:	2868			REAR FILTER #:	2869				
FINAL LEAK RATE (CFM):	<0.01	@	5	IN-HG	FINAL LEAK RATE (CFM):	<0.01	@	5	IN-HG

Run Time: **150** Firebox Delta T **2.6**

ET	GAS METER VOLUME	SAMPLE RATE (FT3/MIN)	PROPORTIONAL RATE	FLUE DRAFT	ORIFICE DELTA H	FILTER VAC	1	2	3	4	5	6	METER	STOVE AVG T
							TEMPERATURES							
							LEFT SIDE	RIGHT SIDE	FILTER	FB TOP	FB BOT			
0	0	0	NA	0	0	1	352	338	73	184	172	75	234	
10	1.363	0.136	100	-0.05	1.98	1.97	317	304	76	198	148	76	221	
20	2.730	0.137	102	-0.07	1.97	1.39	332	324	79	292	164	78	252	
30	4.096	0.137	101	-0.07	1.95	1.62	358	350	79	317	151	81	260	
40	5.473	0.138	102	-0.07	1.99	1.47	396	380	80	362	147	84	282	
50	6.852	0.138	101	-0.06	1.98	2.03	429	410	79	349	147	87	292	
60	8.236	0.138	100	-0.05	1.97	2.04	442	423	79	300	147	90	288	
70	9.623	0.139	#DIV/0!	-0.05	1.97	1.72	437	412	79	251	146	91	312	
80	11.015	0.139	#DIV/0!	-0.04	1.97	2	417	396	78	215	146	93	294	
90	12.408	0.139	#DIV/0!	-0.04	1.97	2	399	383	78	193	144	95	280	
100	13.803	0.140	#DIV/0!	-0.03	1.98	1.73	381	369	77	178	144	96	268	
110	15.203	0.140	#DIV/0!	-0.03	1.97	2.03	368	358	77	169	142	97	259	
120	16.604	0.140	#DIV/0!	-0.03	1.97	1.46	351	348	77	164	141	97	251	
130	18.007	0.140	#DIV/0!	-0.03	1.98	2.02	340	343	77	161	140	98	246	
140	19.409	0.140	#DIV/0!	-0.03	1.97	1.86	332	338	77	160	140	99	243	
150	20.813	0.140	#DIV/0!	-0.02	1.98	1.76	322	330	78	157	139	99	237	

							1	2	3	4	5	6	
							TEMPERATURES						
ET	GAS METER VOLUME	SAMPLE RATE(FT3/MIN)	PROPORTIONAL RATE	FLUE DRAFT	ORIFICE DELTA H	FILTER VAC	LEFT SIDE	RIGHT SIDE	FILTER	FB TOP	FB BOT	METER	STOVE AVG T

ET	GAS METER VOLUME	SAMPLE RATE(FT3/MIN)	PROPORTIONAL RATE	FLUE DRAFT	ORIFICE DELTA H	FILTER VAC	1	2	3	4	5	6	METER	STOVE AVG T
							TEMPERATURES							
	20.813	0.139	#DIV/0!	-0.042	1.973333	1.75625	373	363	78	228	147	90	-3	
	TOTAL	AVG	AVG	AVG	AVG	AVG	AVG	AVG	AVG	AVG	AVG	AVG	<b>DT</b>	

# Ambient Sample Results:

JOB NUMBER: 037-S-048-6 B\_1\_Hour

TECHNICIAN: GEN

DATE: 8\_11\_16

RUN NUMBER: 3

METER Y FACTOR: 1.003

	<u>Sample Volume (L)</u>	<u>Meter Temp °F</u>	<u>ΔH</u>	<u>ΔP</u>
Start	0	90	0	0
End	843.53	98.3	0	0

SAMPLE INFORMATION	
Total Sample Volume - Vm	843.530 Liters
Total Sample Volume - Vm	29.789 ft <sup>3</sup>
Average Sample Rate	0.50 ft <sup>3</sup> /min
Sample Time	60.00 Minutes
Average Meter Temperature	94.15 °F
Total Sample Volume (Standard Conditions) - Vmstd	28.583 dscf
Total Particulates	<span style="border: 1px solid black; padding: 2px;">0.0</span> mg
Particulate Concentration (dry-standard)	<span style="border: 1px solid black; padding: 2px;">0.000000000</span> grams/dscf
Particulate Emission Rate	<span style="border: 1px solid black; padding: 2px;">0.000000000</span> grams/hour



JOB NUMBER 037-S-048-6 B\_1\_Hour

RUN # 3  
 DATE: 8\_11\_16

BURN RATE 3.37 KG/HR DRY

FILTER A PARTICULATE 3.7 mg

FILTER B PARTICULATE  mg

Total Sample Volume - Vm  
 Average Gas Velocity in Dilution Tunnel - vs  
 Average Gas Flow Rate in Dilution Tunnel - Qsd  
 Total Sample Volume (Standard Conditions) - Vmstd

Average Tunnel Temperature  
 Average Delta p

Average Gas Meter Temperature  
 Average Delta H  
 Total Time of Test

Total Particulates

Particulate Concentration (dry-standard)  
**Ambient Train (dry-standard)**  
**Net (dry-standard)**  
 Particulate Emission Rate  
 Total PM Emissions

Average Total PM Emissions  
 AVERAGE PARTICULATE  
 EMISSIONS RATE

% OF AVERAGE

Emissions Factor

SAMPLE A INFORMATION		SAMPLE B INFORMATION	
8.37			
13.99	feet/second		feet/second
9120.56	dscf/hour		dscf/hour
8.24	dscf		dscf
101.6	F		F
0.042			
82	F		F
2.02	in-h20		in-h20
60	min		min
3.7	mg		mg
0.00045	grams/dscf		grams/dscf
0.000000000	grams/dscf		grams/dscf
0.000449071	grams/dscf		grams/dscf
4.10	grams/hour		grams/hour
4.10	grams		grams
		4.10	grams
		2.05	grams/hour
200.0		0.0	
1.217	g/Kg -Dry	0.000	g/Kg -Dry

PREBURN

JOB # 037-S-048-6 B\_1\_Hour

Model Designation BUCK 21NC

TECHNICIAIGEN

DATE: 8\_12\_16

RUN #: 4

READING INTERVAL: 10

Run Time: 70

Tunnel Traverse Information									
	Pt.1	Pt.2	Pt.3	Pt.4	Pt.5	Pt.6	Pt.7	Pt.8	
dP	0.038	0.044	0.042	0.040	0.041	0.044	0.042	0.041	0.042
Temperature	110	110	110	110	110	110	110	110	110.000

ET	SCALE READING	FLUE DRAFT	TEMPERATURES					STOVE AVG T
			1	2	3	4	5	
			LEFT SIDE	RIGHT SIDE	BACK	TOP	BOTTOM	
0	11.1	-0.055	399	404	142	241	167	270.6
10	8.2	-0.089	387	396	130	307	154	274.8
20	5.9	-0.085	427	432	133	400	153	309
30	4	-0.081	464	471	140	428	154	331.4
40	2.9	-0.069	482	493	189	475	161	360
50	2.5	-0.056	457	469	210	410	171	343.4
60	2.2	-0.05	420	445	161	301	164	298.2
70	2.2	-0.038	391	405	136	228	155	263

Dilution Tunnel MW(dry): 29.00 lb/lb-mole  
 Dilution Tunnel MW(wet): 28.78 lb/lb-mole  
 Dilution Tunnel H2O: 2.00 %  
 Dilution Tunnel Static: -0.400 In H2O  
 Tunnel Area: 0.196 ft<sup>2</sup>  
 Pitot Tube Cp: 0.99

Tunnel Velocity: 14.46183 ft/sec.  
 Intial Tunnel Flow: 149.8171 scfm  
 Average Tunnel Flow: 147.0083 scfm

Notes:



Run # 4  
 Date: 8/12/16

Dilution Tunnel MW(dry): 29.00 lb/lb-mole  
 Dilution Tunnel MW(wet): 28.78 lb/lb-mole  
 Dilution Tunnel H2O: 2.00 %  
 Dilution Tunnel Static: -0.400 In H2O  
 Tunnel Area: 0.196 ft<sup>2</sup>  
 Pitot Tube Cp: 0.99

Dilution Tunnel Traverse Data								
	Pt.1	Pt.2	Pt.3	Pt.4	Pt.5	Pt.6	Pt.7	Pt.8
dP	0.038	0.044	0.042	0.040	0.041	0.044	0.042	0.041
Temperature	110	110	110	110	110	110	110	110

0.042  
110.000

Tunnel Velocity: 14.462 ft/sec.  
 Intial Tunnel Flow: 149.82 scfm  
 Average Tunnel Flow: 147.01 scfm

JOB #	037-S-048-6 B_1_Hour																			
TECHNICIAN	GEN										ROOM TEMP (F)		76.7		BEG	MID	END	AVG		
DATE:	8_12_16												BAROMETRIC		29.99	29.99	29.99	29.99		
RUN #:	4																			
READING INTERVAL:	10																			
SAMPLE BOX :	A		METER Y FACTOR:		1.002												PROBE MATERIAL:		SS	
FRONT FILTER #:	2872&2877		REAR FILTER #:		2873															
FINAL LEAK RATE (CFM):	<0.01		@		5		IN-HG		FINAL LEAK RATE (CFM)		<0.01		@		5		IN-HG			
Run Time:	60		AMBIENT FILTER #:		2876		VOLUME		501.49		LITERS		FUEL MOISTURE DB		20.4		%			
			FINAL LEAK RATE (CFM):		<0.01		@		5		IN-HG									
TEST START TIME:	9:40																			
										TEMPERATURES										
	GAS METER	SAMPLE	TUNNEL	ORIFICE	FILTER	TUNNEL VEL	Proportional	Scale	Weight	TUNNEL	FLUE	FILTER	FB REAR	FB	METER	AMBIENT				
ET	VOLUME	RATE(FT3/MIN)	DELTA P	DELTA H	VAC	FT/SEC	Rate (%)	Weight	Chg	TEMP	TEMP	TEMP	TEMP	INT	TEMP	TEMP				
0	0.000	0.000	0.042	0.01	-0.06		NA	8.9	0	103	323	79	133	4167.79	77	75				
10	1.368	0.137	0.042	2	-0.76	14.664	102	7	1.9	161	775	86	154	4168.2	78	75				
20	2.756	0.139	0.042	2.01	-1.71	14.687	103	4.4	2.6	163	750	86	159	4168.58	81	76				
30	4.149	0.139	0.042	2.01	-1.41	14.628	102	2.5	1.9	158	731	86	142	4169.07	85	76				
40	5.545	0.140	0.042	2	-1.28	14.474	100	1.4	1.1	145	618	85	141	4169.65	88	77				
50	6.950	0.141	0.042	2.01	-1.93	14.269	99	0.9	0.5	128	491	83	140	4170.26	91	77				
60	8.362	0.141	0.042	2.02	-1.84	14.147	98	0.6	0.3	118	422	83	137	4170.97	94	77				

TEST START TIME:		9:40								1	2	3	4	5	6	
										TEMPERATURES						
ET	GAS METER VOLUME	SAMPLE RATE(FT3/MIN)	TUNNEL DELTA P	ORIFICE DELTA H	FILTER VAC	TUNNEL VEL FT/SEC	Proportional Rate (%)	Scale Weight	Weight Chg	TUNNEL TEMP	FLUE TEMP	FILTER TEMP	FB REAR TEMP	FB INT	METER TEMP	AMBIENT TEMP

TEST START TIME:		9:40								1	2	3	4	5	6	
										TEMPERATURES						
	GAS METER	SAMPLE	TUNNEL	ORIFICE	FILTER	TUNNEL VEL	Proportional	Scale	Weight	TUNNEL	FLUE	FILTER	FB REAR	FB	METER	AMBIENT
ET	VOLUME	RATE(FT3/MIN)	DELTA P	DELTA H	VAC	FT/SEC	Rate (%)	Weight	Chg	TEMP	TEMP	TEMP	TEMP	INT	TEMP	TEMP
	8.362		0.042	2.01		14.478	100.6			139	587				85	76

JOB #	037-S-048-6 B_1_Hour									
TECHNICIAN	GEN									
DATE:	8_12_16									
RUN #:	4									
READING INTERVAL:	10									
SAMPLE BOX :	B	METER Y FACTOR:	1.001	PROBE MATERIAL:			SS			
FRONT FILTER #:	2874				REAR FILTER #:	2875				
FINAL LEAK RATE (CFM):	<0.01	@	5	IN-HG	FINAL LEAK RATE (CFM):	<0.01	@	5	IN-HG	

Run Time: 90 Firebox Delta T **24.95**

ET	GAS METER VOLUME	SAMPLE RATE (FT <sup>3</sup> /MIN)	PROPORTIONAL RATE	FLUE DRAFT	ORIFICE DELTA H	FILTER VAC	1	2	3	4	5	6	METER	STOVE AVG T
							TEMPERATURES							
							LEFT SIDE	RIGHT SIDE	FILTER	FB TOP	FB BOT			
0	0	0	NA	0	0	1	385	396	78	217	153	77	257	
10	1.362	0.136	102	-0.09	1.97	1.7	373	366	85	282	142	78	263	
20	2.729	0.137	102	-0.08	1.97	1.59	425	417	86	457	155	81	323	
30	4.107	0.138	102	-0.08	2	1.67	473	471	87	437	149	84	334	
40	5.490	0.138	101	-0.07	1.98	2.11	508	511	85	417	149	87	345	
50	6.876	0.139	99	-0.06	1.98	1.52	518	505	83	325	149	90	327	
60	8.266	0.139	98	-0.06	1.98	2.2	489	473	83	263	148	93	302	
70	9.665	0.140	#DIV/0!	-0.05	1.99	2.3	457	439	84	225	146	95	317	
80	11.068	0.140	#DIV/0!	-0.05	1.99	2.03	429	415	85	202	144	97	298	
90	12.471	0.140	#DIV/0!	-0.04	1.99	2.37	406	392	84	187	142	98	282	



ET	GAS METER VOLUME	SAMPLE RATE(FT3/MIN)	PROPORTIONAL RATE	FLUE DRAFT	ORIFICE DELTA H	FILTER VAC	1	2	3	4	5	6	STOVE AVG T
							TEMPERATURES						

							1	2	3	4	5	6		
							TEMPERATURES							
ET	GAS METER VOLUME	SAMPLE RATE(FT3/MIN)	PROPORTIONAL RATE	FLUE DRAFT	ORIFICE DELTA H	FILTER VAC	LEFT SIDE	RIGHT SIDE	FILTER	FB TOP	FB BOT	METER	STOVE AVG T	
	12.471	0.139	#DIV/0!	-0.058	1.983333	1.849	446	439	84	301	148	88	-25	
	TOTAL	AVG	AVG	AVG	AVG	AVG	AVG	AVG	AVG	AVG	AVG	AVG	<b>DT</b>	

281.75

# Ambient Sample Results:

JOB NUMBER: 037-S-048-6 B\_1\_Hour

TECHNICIAN: GEN

DATE: 8\_12\_16

RUN NUMBER: 4

METER Y FACTOR: 1.003

	<u>Sample Volume (L)</u>	<u>Meter Temp °F</u>	<u>ΔH</u>	<u>ΔP</u>
Start	0	90	0	0
End	501.49	96	0	0

SAMPLE INFORMATION	
Total Sample Volume - Vm	501.490 Liters
Total Sample Volume - Vm	17.710 ft <sup>3</sup>
Average Sample Rate	0.30 ft <sup>3</sup> /min
Sample Time	60.00 Minutes
Average Meter Temperature	93 °F
Total Sample Volume (Standard Conditions) - Vmstd	17.000 dscf
Total Particulates	<span style="border: 1px solid black; padding: 2px;">0.2</span> mg
Particulate Concentration (dry-standard)	<span style="border: 1px solid black; padding: 2px;">0.000011765</span> grams/dscf
Particulate Emission Rate	<span style="border: 1px solid black; padding: 2px;">0.000200000</span> grams/hour

JOB NUMBER 037-S-048-6 B\_1\_Hour

RUN # 4  
 DATE: 8\_12\_16

BURN RATE 3.35 KG/HR DRY

FILTER A PARTICULATE 3.5 mg

FILTER B PARTICULATE  mg

Total Sample Volume - Vm  
 Average Gas Velocity in Dilution Tunnel - vs  
 Average Gas Flow Rate in Dilution Tunnel - Qsd  
 Total Sample Volume (Standard Conditions) - Vmstd

Average Tunnel Temperature  
 Average Delta p

Average Gas Meter Temperature  
 Average Delta H  
 Total Time of Test

Total Particulates

Particulate Concentration (dry-standard)  
**Ambient Train (dry-standard)**  
**Net (dry-standard)**  
 Particulate Emission Rate  
 Total PM Emissions

Average Total PM Emissions  
 AVERAGE PARTICULATE  
 EMISSIONS RATE

% OF AVERAGE

Emissions Factor

SAMPLE A INFORMATION		SAMPLE B INFORMATION	
8.36			
14.46	feet/second		feet/second
8820.50	dscf/hour		dscf/hour
8.18	dscf		dscf
139.4	F		F
0.042			
85	F		F
2.01	in-h20		in-h20
60	min		min
3.5	mg		mg
0.00043	grams/dscf		grams/dscf
0.000011765	grams/dscf		grams/dscf
0.000416183	grams/dscf		grams/dscf
3.67	grams/hour		grams/hour
3.67	grams		grams
		3.67	grams
		1.84	grams/hour
200.0		0.0	
1.095	g/Kg -Dry	0.000	g/Kg -Dry

## CSA B415.1-10 Weighted Average



Weighted Average: **70.5** %

Client: New Buck Corporation  
Model: 21NC  
Tracking No.: 48  
Project No.: 037-S-048-6 B  
Test Dates: 8/9/16 - 8/16/16

Burn Rate Category	1
Burn Rate (kg/hr-dry)	0.77
OA Efficiency %	72.9
Emissions Rate Cap (g/hr)	15
Weighting Factor	21.24%
Run Number	1

Burn Rate Category	2
Burn Rate (kg/hr-dry)	0.99
OA Efficiency %	69.4
Emissions Rate Cap (g/hr)	15
Weighting Factor	26.15%
Run Number	2

Burn Rate Category	3
Burn Rate (kg/hr-dry)	1.35
OA Efficiency %	73.1
Emissions Rate Cap (g/hr)	15
Weighting Factor	32.73%
Run Number	3

Burn Rate Category	4
Burn Rate (kg/hr-dry)	2.24
OA Efficiency %	65.2
Emissions Rate Cap (g/hr)	18
Weighting Factor	19.88%
Run Number	4

CSA B415.1-10 - Weighted Average



Client: New Buck Corporation  
Model: 21NC  
Tracking No.: 48  
Project No.: 037-S-048-6 B  
Test Dates: 8/9/16 - 8/16/16

### EPA Method 28 - Weighted Average

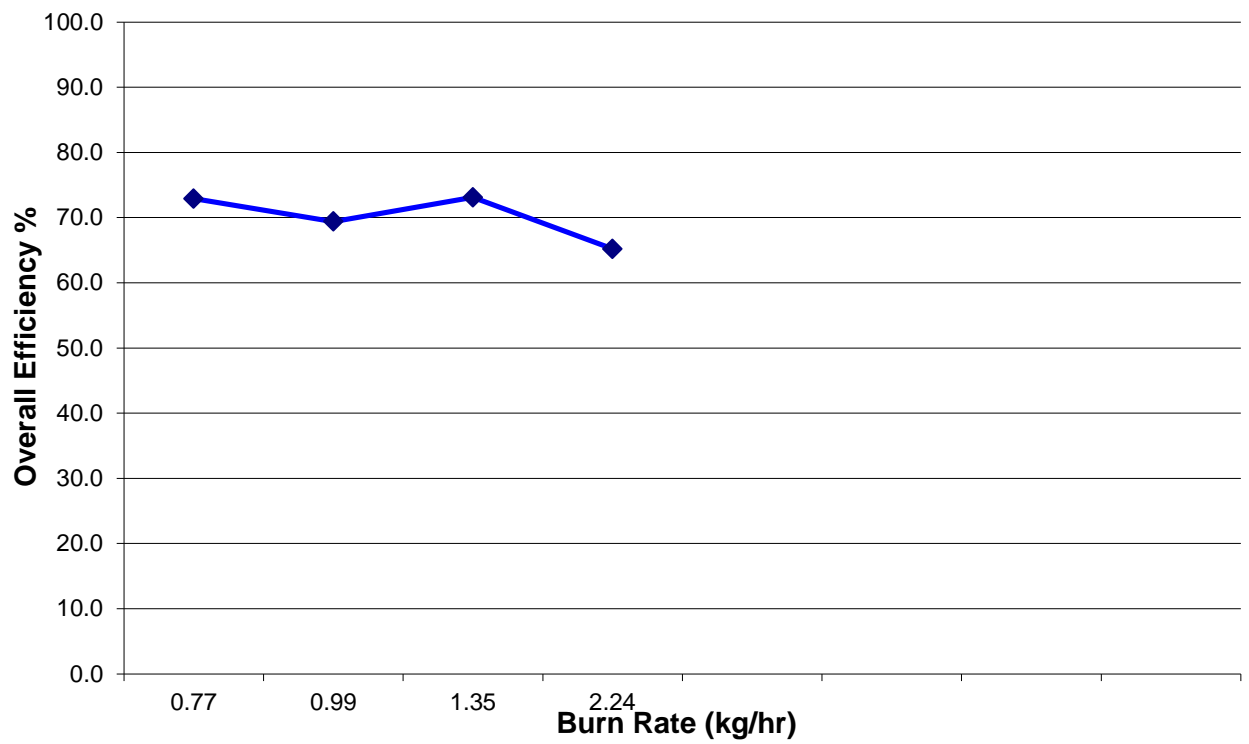

VERSION: 2.4

4/15/2010

Manufacturer: New Buck Corporation

Appliance Type: Non-Cat (Cat, Non-Cat, Pe

Model: 21NC

Date: 8/18/2016

Run: 1

Temp. Units: F (F or C)

Weight Units: lb (kg or lb)

Control #: 037-S-048-6B

Test Duration: 270

Burn Category: 1

Wood Moisture (% DRY): 20.9

Wood Moisture (% wet): 17.29

Load Weight (lb wet): 9.20

Burn Rate (dry kg/h): 0.77

Total Particulate Emissions: 4.38 g

Fuel Data	
	D. Fir
HHV	19,810 kJ/kg
%C	48.73
%H	6.87
%O	43.90
%Ash	0.50

Elapsed Time (min)	Fuel Weight Remaining (lb)	Averages				
		Flue Gas	Room Temp (F)	O2	CO2	CO
		217.8	75.3	12.96	7.01	1.77
0	9.2	196.0	71.0	18.39	1.73	1.26
10	8.0	393.0	72.0	11.78	9.51	0.65
20	6.7	420.0	71.0	9.40	12.16	0.75
30	5.4	418.0	71.0	7.16	14.31	0.88
40	4.1	437.0	73.0	5.47	15.95	0.92
50	3.1	404.0	74.0	7.66	13.70	0.23
60	2.4	339.0	75.0	10.00	11.16	0.10
70	2.1	281.0	75.0	12.14	8.72	0.33
80	1.8	256.0	76.0	12.12	8.31	0.77
90	1.7	220.0	76.0	12.93	7.06	1.39
100	1.5	201.0	76.0	13.04	6.77	1.75
110	1.4	189.0	76.0	13.10	6.84	1.71
120	1.3	182.0	76.0	13.11	6.45	2.11
130	1.2	170.0	76.0	13.18	6.39	2.14
140	1.0	167.0	76.0	13.14	6.32	2.31
150	0.9	163.0	76.0	13.25	6.11	2.38
160	0.8	159.0	76.0	13.46	5.82	2.58
170	0.7	155.0	76.0	13.57	5.75	2.49
180	0.7	151.0	76.0	14.17	4.98	2.64
190	0.6	146.0	76.0	14.45	4.69	2.71
200	0.4	141.0	76.0	14.67	4.59	2.64
210	0.4	136.0	77.0	15.14	4.12	2.37
220	0.4	133.0	77.0	15.10	4.24	2.44
230	0.3	134.0	76.0	14.38	4.84	2.86
240	0.2	133.0	77.0	14.80	4.46	2.63
250	0.1	129.0	77.0	15.54	3.99	2.26
260	0.1	124.0	77.0	15.77	3.74	2.21
270	0.0	120.0	77.0	15.94	3.61	2.14

allet)

- Douglas Fir
- Oak



Manufacturer: aw Buck Corporation

Model: 21NC

Date: 8/18/2016

Run: 1

Control #: 037-S-048-6B

Test Duration: 270 min

Overall Heating Efficiency:

Combustion Efficiency:

Heat Transfer Efficiency:

	HHV	LHV
Eff	72.9%	78.8%
Comb Eff	92.1%	92.1%
HT Eff	79.1%	85.5%
Output	11,079	kJ/h
Burn Rate	0.77	kg/h
Grams CO	378	g
Input	15,199	kJ/h
MC wet	17.29	
<b>Averages</b>	1.77	7.01

Heat Output: 10,509

Heat Input: 14,418

Ultimate CO2

CO2-ult 19.64

Burn Duration: 4.5

Fo

1.061

Burn Rate: 1.7

Stack Temp: 218.6

INPUT DATA				Oxygen Calculation			Input Data		Combust	Heat
Elapsed Time	Weight Remaining (kg)	% CO [e]	% CO2 [d]	Excess Air EA	Total O2	Calc. % O2 [g]	Flue Gas (°C)	Room Temp (°C)	Eff %	Transfer %
0	4.17	1.26	1.73	557.0%	20.74	18.38	91.1	21.7	67.6%	65.8%
10	3.63	0.65	9.51	93.3%	20.27	10.43	200.6	22.2	94.9%	76.4%
20	3.04	0.75	12.16	52.2%	20.09	7.55	215.6	21.7	95.3%	77.9%
30	2.45	0.88	14.31	29.3%	19.94	5.19	214.4	21.7	95.2%	79.4%
40	1.86	0.92	15.95	16.4%	19.83	3.42	225.0	22.8	95.5%	79.7%
50	1.41	0.23	13.70	41.0%	20.02	6.21	206.7	23.3	98.7%	79.7%
60	1.09	0.10	11.16	74.4%	20.20	8.99	170.6	23.9	99.5%	80.3%
70	0.95	0.33	8.72	117.0%	20.34	11.46	138.3	23.9	97.3%	80.6%
80	0.82	0.77	8.31	116.3%	20.34	11.65	124.4	24.4	93.2%	81.2%
90	0.77	1.39	7.06	132.5%	20.38	12.63	104.4	24.4	86.7%	81.4%
100	0.68	1.75	6.77	130.6%	20.38	12.73	93.9	24.4	83.4%	81.9%
110	0.64	1.71	6.84	129.7%	20.38	12.68	87.2	24.4	83.9%	82.6%
120	0.59	2.11	6.45	129.5%	20.37	12.87	83.3	24.4	80.1%	82.3%
130	0.54	2.14	6.39	130.3%	20.38	12.92	76.7	24.4	79.8%	82.9%
140	0.45	2.31	6.32	127.6%	20.37	12.90	75.0	24.4	78.5%	82.9%

150	0.41	2.38	6.11	131.4%	20.38	13.08	72.8	24.4	77.5%	82.9%
160	0.36	2.58	5.82	133.8%	20.39	13.28	70.6	24.4	75.4%	82.7%
170	0.32	2.49	5.75	138.4%	20.40	13.40	68.3	24.4	75.8%	82.9%
180	0.32	2.64	4.98	157.8%	20.44	14.14	66.1	24.4	72.4%	82.2%
190	0.27	2.71	4.69	165.4%	20.45	14.41	63.3	24.4	70.9%	82.1%
200	0.18	2.64	4.59	171.7%	20.46	14.55	60.6	24.4	71.0%	82.4%
210	0.18	2.37	4.12	202.7%	20.51	15.21	57.8	25.0	71.1%	82.4%
220	0.18	2.44	4.24	194.1%	20.50	15.04	56.1	25.0	71.0%	82.7%
230	0.14	2.86	4.84	155.1%	20.43	14.16	56.7	24.4	70.5%	83.0%
240	0.09	2.63	4.46	177.1%	20.47	14.70	56.1	25.0	70.6%	82.8%
250	0.05	2.26	3.99	214.3%	20.53	15.41	53.9	25.0	71.4%	82.8%
260	0.05	2.21	3.74	230.1%	20.55	15.70	51.1	25.0	70.7%	82.9%
270	0.00	2.14	3.61	241.6%	20.56	15.88	48.9	25.0	70.6%	83.1%

	Air Fuel Ratio (A/F)		
72.9%	Dry Molecular Weight (Md)	29.62	
92.1%	Dry Moles Exhaust Gas (Nr):	420.60	%HC
79.1%	Air Fuel Ratio (A/F)	11.95	1.32

Combustion Efficiency: 92.1%  
 Total Input (kJ): 68,397  
 Total Output (kJ): 49,855  
 Efficiency: 72.9%  
 Total CO (g): 377.86

Btu/h 11,079 kJ/h  
 Btu/h 15,199 kJ/h

h

lb/h 0.8 kg/h

Deg. F 103.6 Deg. C

#DIV/0!	14.4	0.92	78.07	0.02	78.07	68768	4.06	6.87	2.74	19810.00	17.29
Net Eff %	Air Fuel Ratio	Wet Wt Now Wt	% Wet Consumed x	Dry Wt. Now Wtdn	% Dry Comsumed y	Fuel Properties			Oxygen /16= [c]	Calorific Value	Mw Moisture Fuel Burnt
						Total Input	Carbon /12= [a]	Hydrogen /1= [b]			
44.5%	37.2	4.17	0.00	3.45	0.00	0	4.06	6.87	2.74	19810.00	17.29
72.5%	11.5	3.63	13.04	3.00	13.04	13754	4.06	6.87	2.74	19810.00	17.29
74.2%	9.1	3.04	27.17	2.51	27.17	9665	4.06	6.87	2.74	19810.00	17.29
75.6%	7.7	2.45	41.30	2.03	41.30	9665	4.06	6.87	2.74	19810.00	17.29
76.1%	7.0	1.86	55.43	1.54	55.43	8550	4.06	6.87	2.74	19810.00	17.29
78.7%	8.5	1.41	66.30	1.16	66.30	6319	4.06	6.87	2.74	19810.00	17.29
79.9%	10.5	1.09	73.91	0.90	73.91	3717	4.06	6.87	2.74	19810.00	17.29
78.4%	13.0	0.95	77.17	0.79	77.17	2230	4.06	6.87	2.74	19810.00	17.29
75.7%	12.9	0.82	80.43	0.68	80.43	1487	4.06	6.87	2.74	19810.00	17.29
70.6%	13.6	0.77	81.52	0.64	81.52	1115	4.06	6.87	2.74	19810.00	17.29
68.3%	13.4	0.68	83.70	0.56	83.70	1115	4.06	6.87	2.74	19810.00	17.29
69.2%	13.4	0.64	84.78	0.53	84.78	743	4.06	6.87	2.74	19810.00	17.29
66.0%	13.2	0.59	85.87	0.49	85.87	743	4.06	6.87	2.74	19810.00	17.29
66.2%	13.3	0.54	86.96	0.45	86.96	1115	4.06	6.87	2.74	19810.00	17.29
65.0%	13.1	0.45	89.13	0.38	89.13	1115	4.06	6.87	2.74	19810.00	17.29

64.2%	13.2	0.41	90.22	0.34	90.22	743	4.06	6.87	2.74	19810.00	17.29
62.3%	13.3	0.36	91.30	0.30	91.30	743	4.06	6.87	2.74	19810.00	17.29
62.8%	13.6	0.32	92.39	0.26	92.39	372	4.06	6.87	2.74	19810.00	17.29
59.5%	14.6	0.32	92.39	0.26	92.39	372	4.06	6.87	2.74	19810.00	17.29
58.2%	15.0	0.27	93.48	0.23	93.48	1115	4.06	6.87	2.74	19810.00	17.29
58.5%	15.3	0.18	95.65	0.15	95.65	743	4.06	6.87	2.74	19810.00	17.29
#DIV/0!	17.1	0.18	95.65	0.15	95.65	0	4.06	6.87	2.74	19810.00	17.29
58.8%	16.6	0.18	95.65	0.15	95.65	372	4.06	6.87	2.74	19810.00	17.29
58.5%	14.4	0.14	96.74	0.11	96.74	743	4.06	6.87	2.74	19810.00	17.29
58.4%	15.6	0.09	97.83	0.08	97.83	743	4.06	6.87	2.74	19810.00	17.29
59.1%	17.8	0.05	98.91	0.04	98.91	372	4.06	6.87	2.74	19810.00	17.29
58.6%	18.7	0.05	98.91	0.04	98.91	743	4.06	6.87	2.74	19810.00	17.29
58.7%	19.3	0.00	100.00	0.00	100.00	372	4.06	6.87	2.74	19810.00	17.29

Moisture Content MCwb: 17.29

64,871	(Btu)	Moisture of Wood (wet basis):	17.29	Dry kg :	3.45
47,285	(Btu)	Initial Dry Weight Wtdo (kg):	3.45	CA:	48.73
		Moisture Content Dry	20.90	HY:	6.87
				OX:	43.90

Load Weight (kg):	4.17				
Fuel Heating:	HHV	LHV		HHV	LHV
Value in kJ/kg - CV:	19810.00	18328.69	Btu/lb	8522.48	7885.21

78.75	20.89	2.22	7.16	0.24	0.22	30.21	67.31	9.35	1.25	393.65	32.01
Mass Balance (moles/100 mole dry flue gas)					kg Wood per 100 mole dfp Nk	Moles per kg of Dry Wood					
[h]	[u]	[w]	[j]	[k]		CO2	O2	CO	HC	N2	H2O
78.63	20.86	0.77	2.35	0.15	0.08	22.46	238.62	16.36	2.00	1020.64	30.52
79.41	21.06	2.52	8.50	0.08	0.25	37.91	41.59	2.59	0.31	316.54	33.90
79.54	21.10	3.20	10.81	0.10	0.32	38.15	23.70	2.35	0.30	249.56	33.91
79.62	21.12	3.77	12.71	0.12	0.38	38.15	13.83	2.35	0.32	212.25	33.88
79.71	21.14	4.19	14.12	0.13	0.42	38.29	8.20	2.21	0.31	191.39	33.91
79.86	21.18	3.44	11.76	0.02	0.34	40.07	18.15	0.67	0.07	233.59	34.38
79.75	21.15	2.77	9.52	0.00	0.28	40.45	32.57	0.36	0.00	289.07	34.52
79.49	21.09	2.24	7.62	0.03	0.22	39.20	51.50	1.48	0.13	357.31	34.26
79.27	21.03	2.26	7.57	0.09	0.22	36.97	51.81	3.43	0.42	352.69	33.69
78.92	20.93	2.13	6.94	0.18	0.21	33.38	59.70	6.57	0.86	373.14	32.80
78.75	20.89	2.16	6.94	0.23	0.21	31.56	59.36	8.16	1.09	367.11	32.34
78.77	20.89	2.16	6.97	0.23	0.22	31.80	58.95	7.95	1.06	366.19	32.39
78.57	20.84	2.18	6.91	0.29	0.22	29.76	59.37	9.73	1.32	362.46	31.88
78.55	20.84	2.17	6.88	0.29	0.22	29.56	59.76	9.90	1.35	363.44	31.83
78.47	20.82	2.20	6.94	0.32	0.22	28.83	58.83	10.54	1.44	358.01	31.64

78.43	20.80	2.17	6.81	0.33	0.22	28.29	60.55	11.02	1.51	363.09	31.51
78.32	20.78	2.16	6.70	0.35	0.21	27.13	61.89	12.03	1.65	365.13	31.22
78.36	20.78	2.11	6.58	0.34	0.21	27.35	63.73	11.84	1.62	372.67	31.28
78.24	20.75	1.97	6.03	0.36	0.20	25.46	72.28	13.50	1.85	400.06	30.82
78.19	20.74	1.91	5.83	0.37	0.19	24.63	75.65	14.23	1.95	410.62	30.62
78.22	20.75	1.87	5.70	0.36	0.19	24.68	78.24	14.19	1.94	420.51	30.64
78.30	20.77	1.68	5.12	0.32	0.17	24.69	91.12	14.20	1.92	469.20	30.68
78.28	20.76	1.73	5.27	0.33	0.17	24.68	87.54	14.20	1.93	455.66	30.66
78.14	20.73	1.99	6.06	0.39	0.20	24.40	71.41	14.42	1.99	393.99	30.55
78.21	20.75	1.83	5.58	0.36	0.18	24.43	80.51	14.41	1.97	428.48	30.58
78.34	20.78	1.61	4.94	0.30	0.16	24.84	95.93	14.07	1.90	487.80	30.73
78.35	20.78	1.54	4.69	0.30	0.15	24.43	102.59	14.44	1.94	511.87	30.64
78.37	20.79	1.49	4.53	0.29	0.15	24.41	107.37	14.47	1.94	529.86	30.65

11.61	376.34	3159.31	2374.60	2308.38	2282.95	3047.91	2762.12	297.20	3031.58	3287.09	74429.98
Moisture Present	Stack Temp K	Heat Content Change - Ambient to Stack Temperature						Room Temp K	Energy		
		Flue Gas Constituent							CO2	O2	CO
		CO2	O2	CO	N2	CH4	H2O		CO2	O2	CO
11.61	364.26	2715.04	2065.82	2014.40	1990.91	2564.25	2412.32	294.82	60.97	492.94	4661.09
11.61	473.71	7256.67	5393.31	5227.92	5173.48	7134.26	6250.74	295.37	275.10	224.33	746.82
11.61	488.71	7930.26	5876.36	5691.78	5633.43	7834.98	6803.96	294.82	302.57	139.26	679.35
11.61	487.59	7881.71	5841.72	5658.56	5600.48	7784.08	6764.35	294.82	300.66	80.78	677.14
11.61	498.15	8302.06	6138.53	5942.38	5882.17	8231.49	7102.47	295.93	317.93	50.35	638.22
11.61	479.82	7479.33	5550.48	5378.20	5322.63	7371.36	6429.77	296.48	299.70	100.74	193.99
11.61	443.71	5907.85	4416.92	4287.96	4241.94	5751.07	5128.95	297.04	238.97	143.87	104.13
11.61	411.48	4556.44	3429.94	3335.58	3298.57	4384.32	3991.63	297.04	178.59	176.64	424.72
11.61	397.59	3962.02	2991.04	2910.85	2878.11	3793.63	3484.03	297.59	146.48	154.97	979.42
11.61	377.59	3146.42	2385.63	2324.20	2297.53	2990.10	2782.66	297.59	105.02	142.42	1875.03
11.61	367.04	2720.64	2067.56	2015.48	1992.11	2575.05	2413.42	297.59	85.86	122.72	2325.15
11.61	360.37	2453.39	1867.19	1820.83	1799.57	2316.13	2180.54	297.59	78.01	110.07	2264.18
11.61	356.48	2298.09	1750.49	1707.39	1687.38	2166.24	2044.81	297.59	68.38	103.93	2771.23
11.61	349.82	2032.88	1550.76	1513.13	1495.28	1911.26	1812.33	297.59	60.10	92.68	2816.90
11.61	348.15	1966.78	1500.89	1464.60	1447.29	1847.90	1754.25	297.59	56.71	88.30	2997.74

11.61	345.93	1878.77	1434.43	1399.92	1383.34	1763.67	1676.83	297.59	53.14	86.85	3133.44
11.61	343.71	1790.90	1368.02	1335.27	1319.42	1679.71	1599.44	297.59	48.59	84.66	3419.71
11.61	341.48	1703.18	1301.65	1270.65	1255.54	1596.03	1522.08	297.59	46.58	82.96	3366.31
11.61	339.26	1615.60	1235.33	1206.05	1191.68	1512.62	1444.75	297.59	41.14	89.29	3836.21
11.61	336.48	1506.33	1152.49	1125.34	1111.90	1408.76	1348.13	297.59	37.10	87.19	4043.30
11.61	333.71	1397.28	1069.71	1044.68	1032.16	1305.32	1251.55	297.59	34.48	83.69	4031.34
11.61	330.93	1267.24	970.64	948.05	936.66	1182.79	1135.81	298.15	31.29	88.44	4032.34
11.61	329.26	1202.05	921.06	899.69	888.87	1121.20	1077.91	298.15	29.67	80.63	4032.05
11.61	329.82	1244.98	953.95	931.83	920.62	1161.24	1116.41	297.59	30.38	68.12	4094.42
11.61	329.26	1202.05	921.06	899.69	888.87	1121.20	1077.91	298.15	29.37	74.16	4090.36
11.61	327.04	1115.26	854.98	835.25	825.18	1039.32	1000.73	298.15	27.71	82.02	3993.99
11.61	324.26	1006.97	772.44	754.74	745.62	937.35	904.30	298.15	24.60	79.24	4096.88
11.61	322.04	920.50	706.46	690.35	681.99	856.09	827.19	298.15	22.47	75.85	4104.52



SUMS				AVERAGE	SUMS					
21526.95	31318.64	41964.40	15192.93	6812.56	18542	5399	13142.89	50227	5399	377.86
Flue Gas Constituent				Total Loss Rate	Total Loss	Chemical Loss 1	Sensible and Latent Loss	Total Output	Chem Loss 2	Grams Pro CO
N2	CH4	H2O Comb	H2O Fuel MC							
2032.00	1785.65	1415.66	538.54	10986.85	0	0	0.00	0	0	0.00
1637.62	278.87	1702.50	583.11	5448.36	3783	701	3081.51	9971	701	50.37
1405.90	273.80	1721.85	589.54	5112.27	2494	457	2036.81	7171	457	32.15
1188.73	287.08	1719.01	589.08	4842.46	2362	463	1899.78	7302	463	32.05
1125.77	277.41	1731.58	593.00	4734.25	2043	388	1654.80	6506	388	26.69
1243.34	61.81	1732.96	585.19	4217.72	1345	80	1265.14	4974	80	6.01
1226.21	0.39	1694.95	570.09	3978.59	747	19	727.23	2971	19	1.90
1178.62	119.30	1642.93	556.88	4277.69	482	61	420.98	1749	61	4.68
1015.07	371.88	1598.72	550.99	4817.53	362	101	261.03	1125	101	7.20
857.29	769.81	1533.40	542.84	5825.81	328	148	180.07	787	148	10.36
731.32	976.39	1499.78	538.56	6279.78	354	185	168.74	762	185	12.86
658.99	949.56	1495.00	535.85	6091.67	229	120	108.64	515	120	8.35
611.61	1180.87	1466.73	534.28	6737.03	253	148	105.25	491	148	10.23
543.44	1201.71	1457.15	531.58	6703.55	377	225	152.13	738	225	15.61
518.15	1285.85	1446.66	530.90	6924.30	390	240	149.67	725	240	16.61

502.28	1345.61	1438.09	530.00	7089.41	266	167	98.64	477	167	11.58
481.76	1474.78	1422.43	529.10	7461.04	280	183	97.03	463	183	12.64
467.90	1447.92	1422.74	528.21	7362.62	138	90	48.15	234	90	6.22
476.74	1650.78	1399.65	527.31	8021.12	151	103	47.91	221	103	7.09
456.57	1740.98	1387.48	526.19	8278.80	466	325	141.48	649	325	22.43
434.03	1732.12	1385.40	525.06	8226.13	309	216	93.07	435	216	14.91
439.49	1714.50	1383.62	523.72	8213.39	0	0	0.00	0	0	0.00
405.02	1719.70	1381.30	523.05	8171.42	153	108	45.68	218	108	7.46
362.72	1771.24	1377.28	523.50	8227.65	309	220	89.23	435	220	15.15
380.87	1756.45	1377.59	523.05	8231.85	309	219	90.08	435	219	15.14
402.52	1690.50	1381.87	522.15	8100.76	152	106	45.60	220	106	7.39
381.65	1728.39	1375.07	521.03	8206.87	308	218	89.86	435	218	15.17
361.36	1725.30	1373.00	520.14	8182.63	154	109	44.37	218	109	7.60

28.40
roduced HC

0.00

3.45

2.38

2.50

2.13

0.35

0.00

0.24

0.50

0.78

0.99

0.64

0.79

1.21

1.30

0.91  
0.99  
0.49  
0.56  
1.76  
1.17  
0.00  
0.58  
1.19  
1.18  
0.57  
1.16  
0.58

# Dirigo Laboratories, Inc.

**Manufacturer:** New Buck Corporation  
**Model:** 21NC  
**Date:** 8/18/2016  
**Run:** 1  
**Control #:** 037-S-048-6B  
**Test Duration:** 270  
**Output Category:** 1

	HHV Basis	LHV Basis
Overall Efficiency	72.9%	78.8%
Combustion Efficiency	92.1%	92.1%
Heat Transfer Efficiency	79.1%	85.5%

HHV Output Rate (kJ/h)	11,079	10,509	(Btu/h)
Burn Rate (kg/h)	0.77	1.69	(lb/h)
Input (kJ/h)	15,199	14,418	(Btu/h)

Test Load Weight (dry kg)	3.5	7.6	dry lb
MC wet (%)	17.29		
MC dry (%)	20.90		
Particulate (g)	4.38		
CO (g)	378		
Test Duration (h)	4.5		

Emissions	Particulate	CO
g/MJ Output	0.09	7.58
g/kg Dry Fuel	1.27	109.44
g/h	0.97	83.97
lb/MM Btu Output	0.20	17.61

Air/Fuel Ratio (A/F)	11.95
----------------------	-------

Test Results in Accordance with CSA B415.1-10

### Default Fuel Values

	<b>D. Fir</b>	<b>Oak</b>
<b>HHV (kJ/kg)</b>	19,810	19,887
<b>%C</b>	48.73	50
<b>%H</b>	6.87	6.6
<b>%O</b>	43.9	42.9
<b>%Ash</b>	0.5	0.5

VERSION: 2.4

4/15/2010

Manufacturer: New Buck Corporation

Appliance Type: Non-Cat (Cat, Non-Cat, Pe

Model: 21NC

Date: 8/18/2016

Run: 2

Temp. Units: F (F or C)

Weight Units: lb (kg or lb)

Control #: 037-S-048-6B

Test Duration: 220

Burn Category: 2

Wood Moisture (% DRY): 19.7

Wood Moisture (% wet): 16.46

Load Weight (lb wet): 9.60

Burn Rate (dry kg/h): 0.99

Total Particulate Emissions: 7.06 g

Fuel Data	
	D. Fir
HHV	19,810 kJ/kg
%C	48.73
%H	6.87
%O	43.90
%Ash	0.50

Elapsed Time (min)	Fuel Weight Remaining (lb)	Averages				
		273.7	77.3	13.20	7.02	1.34
Temp. (F)						
		Flue Gas	Room Temp	Flue Gas Composition (%)		
				O2	CO2	CO
0	9.6	210.0	75.0	18.82	1.71	0.89
10	8.4	326.0	75.0	17.23	3.41	0.62
20	7.3	497.0	75.0	4.01	16.98	2.00
30	5.5	514.0	76.0	4.86	16.33	0.74
40	3.9	518.0	76.0	3.76	17.15	1.19
50	2.9	440.0	77.0	8.38	12.72	0.12
60	2.2	381.0	77.0	10.10	11.03	0.08
70	1.9	338.0	77.0	11.56	9.28	0.27
80	1.6	303.0	78.0	12.29	8.40	0.61
90	1.4	268.0	78.0	13.35	6.72	1.36
100	1.2	224.0	78.0	14.00	5.78	1.60
110	1.4	207.0	78.0	14.20	5.64	1.58
120	1.0	200.0	78.0	14.27	5.63	1.68
130	0.9	212.0	78.0	14.95	4.78	1.96
140	0.8	208.0	78.0	15.00	4.75	1.89
150	0.6	204.0	78.0	15.21	4.54	1.96
160	0.5	199.0	78.0	15.38	4.35	1.93
170	0.4	191.0	78.0	15.71	4.02	1.80
180	0.3	181.0	78.0	15.98	3.77	1.74
190	0.2	173.0	78.0	15.96	3.70	1.74
200	0.2	169.0	78.0	16.07	3.68	1.74
210	0.1	169.0	78.0	16.10	3.67	1.77
220	0.0	164.0	78.0	16.35	3.47	1.63

let)

- Dougl
- Oak



Manufacturer: aw Buck Corporation

Model: 21NC

Date: 8/18/2016

Run: 2

Control #: 037-S-048-6B

Test Duration: 220 min

Overall Heating Efficiency:

Combustion Efficiency:

Heat Transfer Efficiency:

	HHV	LHV
Eff	69.4%	75.0%
Comb Eff	91.4%	91.4%
HT Eff	75.9%	82.1%
Output	13,648	kJ/h
Burn Rate	0.99	kg/h
Grams CO	439	g
Input	19,660	kJ/h
MC wet	16.46	
<b>Averages</b>	1.34	7.02

Heat Output: 12,947

Heat Input: 18,649

Ultimate CO2

CO2-ult 19.64

Burn Duration: 3.666666667

Fo

1.061

Burn Rate: 2.2

Stack Temp: 276.6

INPUT DATA				Oxygen Calculation			Input Data		Combust	Heat
Elapsed Time	Weight Remaining (kg)	% CO [e]	% CO2 [d]	Excess Air EA	Total O2	Calc. % O2 [g]	Flue Gas (°C)	Room Temp (°C)	Eff %	Transfer %
0	4.36	0.89	1.71	655.5%	20.77	18.61	98.9	23.9	74.0%	64.0%
10	3.81	0.62	3.41	387.4%	20.67	16.95	163.3	23.9	88.3%	64.2%
20	3.31	2.00	16.98	3.5%	19.69	1.71	258.3	23.9	91.2%	78.6%
30	2.50	0.74	16.33	15.1%	19.81	3.11	267.8	24.4	96.4%	78.1%
40	1.77	1.19	17.15	7.1%	19.73	1.98	270.0	24.4	94.6%	78.3%
50	1.32	0.12	12.72	53.0%	20.09	7.31	226.7	25.0	99.4%	78.2%
60	1.00	0.08	11.03	76.8%	20.21	9.14	193.9	25.0	99.6%	78.9%
70	0.86	0.27	9.28	105.7%	20.31	10.89	170.0	25.0	97.9%	79.0%
80	0.73	0.61	8.40	118.0%	20.35	11.64	150.6	25.6	94.7%	79.5%
90	0.64	1.36	6.72	143.1%	20.41	13.01	131.1	25.6	86.5%	78.8%
100	0.54	1.60	5.78	166.2%	20.45	13.87	106.7	25.6	82.6%	79.8%
110	0.64	1.58	5.64	172.1%	20.46	14.03	97.2	25.6	82.5%	80.6%
120	0.45	1.68	5.63	168.7%	20.46	13.99	93.3	25.6	81.6%	81.0%
130	0.41	1.96	4.78	191.4%	20.49	14.73	100.0	25.6	76.8%	78.6%
140	0.36	1.89	4.75	195.8%	20.50	14.81	97.8	25.6	77.3%	78.9%

150	0.27	1.96	4.54	202.2%	20.51	14.99	95.6	25.6	76.0%	78.7%
160	0.23	1.93	4.35	212.8%	20.53	15.21	92.8	25.6	75.6%	78.7%
170	0.18	1.80	4.02	237.5%	20.56	15.64	88.3	25.6	75.5%	78.7%
180	0.14	1.74	3.77	256.5%	20.58	15.94	82.8	25.6	75.0%	78.9%
190	0.09	1.74	3.70	261.1%	20.58	16.01	78.3	25.6	74.7%	79.4%
200	0.09	1.74	3.68	262.4%	20.58	16.03	76.1	25.6	74.6%	79.7%
210	0.05	1.77	3.67	261.1%	20.58	16.03	76.1	25.6	74.3%	79.7%
220	0.00	1.63	3.47	285.2%	20.60	16.32	73.3	25.6	74.8%	79.8%

	Air Fuel Ratio (A/F)	
69.4%	Dry Molecular Weight (Md)	29.63
91.4%	Dry Moles Exhaust Gas (Nr):	438.79
75.9%	Air Fuel Ratio (A/F)	12.49

%HC  
1.32

Combustion Efficiency: 91.4%  
 Total Input (kJ): 72,086  
 Total Output (kJ): 50,044  
 Efficiency: 69.4%  
 Total CO (g): 439.33

Btu/h 13,648 kJ/h  
 Btu/h 19,660 kJ/h

h

lb/h 1.0 kg/h

Deg. F 135.9 Deg. C

#DIV/0!	17.0	1.03	76.31	0.02	76.31	72461	4.06	6.87	2.74	19810.00	16.46
Net Eff %	Air Fuel Ratio	Wet Wt Now Wt	% Wet Consumed x	Dry Wt. Now Wtdn	% Dry Comsumed y	Fuel Properties			Oxygen /16= [c]	Calorific Value	Mw Moisture Fuel Burnt
						Total Input	Carbon /12= [a]	Hydrogen /1= [b]			
47.4%	43.5	4.36	0.00	3.64	0.00	0	4.06	6.87	2.74	19810.00	16.46
56.7%	28.7	3.81	12.50	3.18	12.50	13141	4.06	6.87	2.74	19810.00	16.46
71.7%	6.1	3.31	23.96	2.77	23.96	10888	4.06	6.87	2.74	19810.00	16.46
75.3%	6.9	2.50	42.71	2.08	42.71	12765	4.06	6.87	2.74	19810.00	16.46
74.1%	6.4	1.77	59.38	1.48	59.38	9762	4.06	6.87	2.74	19810.00	16.46
77.7%	9.3	1.32	69.79	1.10	69.79	6383	4.06	6.87	2.74	19810.00	16.46
78.7%	10.7	1.00	77.08	0.83	77.08	3754	4.06	6.87	2.74	19810.00	16.46
77.3%	12.4	0.86	80.21	0.72	80.21	2253	4.06	6.87	2.74	19810.00	16.46
75.2%	13.0	0.73	83.33	0.61	83.33	1877	4.06	6.87	2.74	19810.00	16.46
68.1%	14.2	0.64	85.42	0.53	85.42	1502	4.06	6.87	2.74	19810.00	16.46
#DIV/0!	15.4	0.54	87.50	0.45	87.50	0	4.06	6.87	2.74	19810.00	16.46
66.5%	15.8	0.64	85.42	0.53	85.42	751	4.06	6.87	2.74	19810.00	16.46
66.0%	15.6	0.45	89.58	0.38	89.58	1877	4.06	6.87	2.74	19810.00	16.46
60.4%	16.7	0.41	90.63	0.34	90.63	751	4.06	6.87	2.74	19810.00	16.46
61.0%	17.0	0.36	91.67	0.30	91.67	1126	4.06	6.87	2.74	19810.00	16.46

59.8%	17.3	0.27	93.75	0.23	93.75	1126	4.06	6.87	2.74	19810.00	16.46
59.5%	17.9	0.23	94.79	0.19	94.79	751	4.06	6.87	2.74	19810.00	16.46
59.4%	19.3	0.18	95.83	0.15	95.83	751	4.06	6.87	2.74	19810.00	16.46
59.2%	20.4	0.14	96.88	0.11	96.88	751	4.06	6.87	2.74	19810.00	16.46
59.4%	20.6	0.09	97.92	0.08	97.92	375	4.06	6.87	2.74	19810.00	16.46
59.5%	20.7	0.09	97.92	0.08	97.92	375	4.06	6.87	2.74	19810.00	16.46
59.2%	20.6	0.05	98.96	0.04	98.96	1126	4.06	6.87	2.74	19810.00	16.46
59.7%	22.0	0.00	100.00	0.00	100.00	375	4.06	6.87	2.74	19810.00	16.46

Moisture Content MCwb: 16.46

68,370	(Btu)	Moisture of Wood (wet basis):	16.46	Dry kg :	3.64
47,464	(Btu)	Initial Dry Weight Wtdo (kg):	3.64	CA:	48.73
		Moisture Content Dry	19.70	HY:	6.87
				OX:	43.90

Load Weight (kg):	4.36				
Fuel Heating:	HHV	LHV		HHV	LHV
Value in kJ/kg - CV:	19810.00	18328.69	Btu/lb	8522.48	7885.21

78.94	20.94	2.10	6.87	0.18	0.21	31.62	85.33	8.14	1.05	465.41	32.42
Mass Balance (moles/100 mole dry flue gas)					kg Wood per 100 mole dfp Nk	Moles per kg of Dry Wood					
[h]	[u]	[w]	[j]	[k]		CO2	O2	CO	HC	N2	H2O
78.79	20.90	0.66	2.08	0.10	0.07	25.85	281.38	13.45	1.51	1191.01	31.51
79.02	20.96	1.01	3.34	0.06	0.10	34.00	169.05	6.18	0.63	787.87	33.26
79.31	21.04	4.75	15.72	0.29	0.47	35.96	3.62	4.24	0.61	167.99	33.30
79.82	21.17	4.23	14.32	0.10	0.42	38.81	7.40	1.76	0.24	189.69	34.03
79.68	21.13	4.56	15.32	0.17	0.45	37.81	4.37	2.62	0.38	175.67	33.77
79.85	21.18	3.16	10.85	0.01	0.31	40.41	23.23	0.38	0.02	253.69	34.49
79.75	21.15	2.74	9.40	0.00	0.27	40.53	33.57	0.29	-0.01	293.05	34.54
79.56	21.10	2.36	8.05	0.02	0.23	39.57	46.45	1.15	0.09	339.21	34.34
79.35	21.05	2.24	7.54	0.07	0.22	37.76	52.32	2.74	0.32	356.65	33.89
78.91	20.93	2.03	6.63	0.18	0.20	33.21	64.29	6.72	0.88	390.04	32.77
78.75	20.89	1.87	6.00	0.21	0.19	31.08	74.59	8.60	1.13	423.38	32.25
78.75	20.89	1.83	5.87	0.21	0.18	30.99	77.11	8.68	1.14	432.68	32.24
78.70	20.88	1.85	5.93	0.22	0.18	30.50	75.79	9.10	1.20	426.43	32.11
78.53	20.83	1.72	5.40	0.26	0.17	27.86	85.89	11.42	1.53	457.70	31.47
78.55	20.84	1.70	5.33	0.25	0.17	28.13	87.68	11.19	1.49	465.19	31.54

78.51	20.82	1.67	5.20	0.26	0.17	27.40	90.48	11.83	1.58	473.88	31.36
78.51	20.82	1.61	5.02	0.26	0.16	27.16	94.96	12.05	1.60	490.17	31.32
78.54	20.83	1.49	4.65	0.24	0.15	27.09	105.35	12.13	1.60	529.22	31.33
78.55	20.84	1.41	4.40	0.23	0.14	26.81	113.35	12.38	1.62	558.73	31.28
78.55	20.84	1.40	4.34	0.23	0.14	26.64	115.29	12.53	1.64	565.61	31.24
78.55	20.83	1.39	4.32	0.23	0.14	26.59	115.85	12.57	1.65	567.60	31.23
78.53	20.83	1.40	4.33	0.23	0.14	26.41	115.31	12.74	1.67	565.06	31.18
78.58	20.84	1.31	4.07	0.21	0.13	26.66	125.39	12.52	1.62	603.82	31.27

10.94	407.45	4400.58	3287.97	3191.46	3157.31	4288.32	3817.23	298.32	3481.15	4719.00	53425.74
Moisture Present	Stack Temp K	Heat Content Change - Ambient to Stack Temperature						Room Temp K	Energy		
		Flue Gas Constituent							CO2	O2	CO
		CO2	O2	CO	N2	CH4	H2O		CO2	O2	CO
10.94	372.04	2943.12	2234.46	2177.66	2152.51	2790.39	2607.44	297.04	76.08	628.72	3836.36
10.94	436.48	5602.33	4194.89	4073.99	4029.93	5439.68	4873.52	297.04	190.49	709.14	1774.66
10.94	531.48	9742.00	7152.98	6911.86	6844.47	9769.21	8257.20	297.04	350.37	25.86	1228.07
10.94	540.93	10146.65	7435.14	7180.73	7111.52	10207.74	8577.21	297.59	393.78	55.01	510.32
10.94	543.15	10247.23	7505.49	7247.84	7178.16	10316.24	8657.09	297.59	387.48	32.83	761.53
10.94	499.82	8290.62	6125.19	5928.26	5868.44	8230.84	7085.20	298.15	335.05	142.30	110.15
10.94	467.04	6862.84	5104.73	4949.21	4897.45	6738.04	5917.83	298.15	278.15	171.37	84.64
10.94	443.15	5841.88	4367.09	4239.46	4193.98	5687.97	5070.90	298.15	231.15	202.86	330.67
10.94	423.71	5001.87	3754.11	3648.09	3608.18	4837.31	4364.73	298.71	188.85	196.41	785.90
10.94	404.26	4194.04	3160.90	3074.87	3040.55	4027.37	3679.93	298.71	139.30	203.20	1922.92
10.94	379.82	3194.04	2419.98	2357.24	2330.28	3039.20	2822.08	298.71	99.26	180.50	2454.69
10.94	370.37	2812.32	2135.15	2080.87	2056.84	2666.37	2491.55	298.71	87.15	164.64	2474.86
10.94	366.48	2655.89	2018.11	1967.22	1944.41	2514.30	2355.60	298.71	81.02	152.95	2593.90
10.94	373.15	2924.32	2218.84	2162.10	2137.21	2775.51	2588.72	298.71	81.47	190.57	3257.67
10.94	370.93	2834.70	2151.89	2097.11	2072.91	2688.16	2510.98	298.71	79.74	188.69	3190.88

10.94	368.71	2745.22	2084.97	2032.15	2008.65	2601.10	2433.28	298.71	75.23	188.66	3371.96
10.94	365.93	2633.58	2001.40	1950.99	1928.36	2492.65	2336.19	298.71	71.53	190.06	3433.52
10.94	361.48	2455.41	1867.82	1821.22	1800.00	2320.03	2180.93	298.71	66.51	196.78	3454.24
10.94	355.93	2233.51	1701.09	1659.16	1639.72	2105.82	1987.02	298.71	59.89	192.82	3522.86
10.94	351.48	2056.63	1567.91	1529.63	1511.64	1935.69	1832.02	298.71	54.79	180.76	3564.82
10.94	349.26	1968.41	1501.39	1464.91	1447.64	1851.04	1754.57	298.71	52.34	173.94	3576.65
10.94	349.26	1968.41	1501.39	1464.91	1447.64	1851.04	1754.57	298.71	51.98	173.12	3622.68
10.94	346.48	1858.33	1418.30	1384.05	1367.69	1745.62	1657.78	298.71	49.55	177.84	3561.80



SUMS				AVERAGE	SUMS					
28052.47	21562.73	35690.20	12028.95	6911.31	22042	6192	15850.32	50419	6192	439.33
Flue Gas Constituent				Total Loss Rate	Total Loss	Chemical Loss 1	Sensible and Latent Loss	Total Output	Chem Loss 2	Grams Pro CO
N2	CH4	H2O Comb	H2O Fuel MC							
2563.66	1346.99	1467.42	509.76	10428.99	0	0	0.00	0	0	0.00
3175.07	563.48	1624.71	534.56	8572.10	5686	1532	4154.18	7454	1532	114.82
1149.80	550.46	1739.09	571.59	5615.25	3086	958	2128.11	7802	958	65.19
1348.99	220.10	1788.34	575.09	4891.63	3152	461	2691.15	9613	461	31.73
1261.01	338.06	1777.28	575.97	5134.16	2530	531	1999.36	7232	531	36.20
1488.74	16.35	1760.67	558.76	4412.02	1422	40	1381.53	4961	40	3.44
1435.22	-10.01	1723.34	545.99	4228.70	801	14	787.56	2953	14	1.56
1422.64	83.38	1683.86	536.72	4491.28	511	46	464.25	1742	46	3.67
1286.86	282.36	1638.11	528.99	4907.47	465	100	364.90	1412	100	7.27
1185.92	783.68	1561.44	521.50	6317.96	479	203	275.61	1023	203	14.27
986.60	1012.84	1509.23	512.11	6755.23	0	0	0.00	0	0	0.00
889.96	1019.09	1497.88	508.49	6642.06	252	132	120.13	499	132	9.21
829.16	1075.62	1487.61	507.00	6727.26	637	346	291.74	1240	346	24.15
978.19	1363.61	1465.10	509.55	7846.16	297	174	123.34	453	174	12.12
964.30	1330.74	1466.06	508.70	7729.11	439	256	183.93	687	256	17.82

951.85	1409.60	1455.40	507.85	7960.54	453	270	182.35	674	270	18.83
945.22	1431.54	1450.06	506.79	8028.71	304	183	120.96	447	183	12.79
952.59	1426.53	1445.68	505.09	8047.41	305	184	121.01	446	184	12.87
916.16	1446.96	1437.47	502.97	8079.12	306	187	118.77	445	187	13.14
854.99	1463.81	1430.86	501.27	8051.31	153	95	57.71	223	95	6.65
821.68	1468.64	1427.93	500.42	8021.62	152	95	56.82	223	95	6.67
818.01	1490.46	1425.70	500.42	8082.37	460	289	170.06	667	289	20.27
825.84	1448.45	1426.96	499.36	7989.81	151	95	56.85	224	95	6.65

31.48
roduced HC

0.00

6.68

5.38

2.52

2.96

0.09

-0.03

0.17

0.48

1.06

0.00

0.69

1.83

0.93

1.36

1.44  
0.97  
0.97  
0.98  
0.50  
0.50  
1.52  
0.49

# Dirigo Laboratories, Inc.

**Manufacturer:** New Buck Corporation  
**Model:** 21NC  
**Date:** 8/18/2016  
**Run:** 2  
**Control #:** 037-S-048-6B  
**Test Duration:** 220  
**Output Category:** 2

	HHV Basis	LHV Basis
Overall Efficiency	69.4%	75.0%
Combustion Efficiency	91.4%	91.4%
Heat Transfer Efficiency	75.9%	82.1%

HHV Output Rate (kJ/h)	13,648	12,947	(Btu/h)
Burn Rate (kg/h)	0.99	2.19	(lb/h)
Input (kJ/h)	19,660	18,649	(Btu/h)

Test Load Weight (dry kg)	3.6	8.0	dry lb
MC wet (%)	16.46		
MC dry (%)	19.70		
Particulate (g)	7.06		
CO (g)	439		
Test Duration (h)	3.666666667		

Emissions	Particulate	CO
g/MJ Output	0.14	8.78
g/kg Dry Fuel	1.94	120.73
g/h	1.93	119.82
lb/MM Btu Output	0.33	20.40

Air/Fuel Ratio (A/F)	12.49
----------------------	-------

Test Results in Accordance with CSA B415.1-10

### Default Fuel Values

	<b>D. Fir</b>	<b>Oak</b>
<b>HHV (kJ/kg)</b>	19,810	19,887
<b>%C</b>	48.73	50
<b>%H</b>	6.87	6.6
<b>%O</b>	43.9	42.9
<b>%Ash</b>	0.5	0.5

VERSION: 2.4

4/15/2010

Manufacturer: New Buck Corporation

Appliance Type: Non-Cat (Cat, Non-Cat, Pe

Model: 21NC

Date: 8/18/2016

Run: 3

Temp. Units: F (F or C)

Weight Units: lb (kg or lb)

Control #: 037-S-048-6B

Test Duration: 150

Burn Category: 3

Wood Moisture (% DRY): 21.3

Wood Moisture (% wet): 17.56

Load Weight (lb wet): 9.00

Burn Rate (dry kg/h): 1.35

Total Particulate Emissions: 4.33 g

Fuel Data	
	D. Fir
HHV	19,810 kJ/kg
%C	48.73
%H	6.87
%O	43.90
%Ash	0.50

Elapsed Time (min)	Fuel Weight Remaining (lb)	Averages				
		Flue Gas Temp. (F)	Room Temp. (F)	O2 (%)	CO2 (%)	CO (%)
		332.9	72.9	12.15	7.79	1.00
0	9.0	202.0	72.0	17.78	1.85	1.12
10	8.1	346.0	71.0	12.38	8.34	0.50
20	6.3	500.0	71.0	6.92	13.95	0.32
30	4.7	531.0	72.0	4.60	16.15	0.50
40	3.1	545.0	72.0	3.44	16.72	0.98
50	2.2	457.0	73.0	8.33	12.18	0.08
60	1.6	378.0	73.0	11.93	8.44	0.20
70	1.4	321.0	73.0	13.28	6.66	0.75
80	1.1	294.0	73.0	13.91	5.80	1.14
90	1.0	273.0	73.0	13.91	5.63	1.51
100	0.8	257.0	73.0	14.35	5.17	1.44
110	0.7	242.0	74.0	14.58	4.99	1.34
120	0.5	253.0	74.0	14.47	5.09	1.42
130	0.3	251.0	74.0	14.59	4.85	1.54
140	0.2	243.0	74.0	14.97	4.44	1.56
150	0.1	234.0	74.0	14.98	4.44	1.62

let)

- Dougl
- Oak



Manufacturer: aw Buck Corporation

Model: 21NC

Date: 8/18/2016

Run: 3

Control #: 037-S-048-6B

Test Duration: 150 min

Overall Heating Efficiency:

Combustion Efficiency:

Heat Transfer Efficiency:

	HHV	LHV
Eff	73.1%	79.0%
Comb Eff	95.1%	95.1%
HT Eff	76.9%	83.1%
Output	19,504	kJ/h
Burn Rate	1.35	kg/h
Grams CO	235	g
Input	26,676	kJ/h
MC wet	17.56	
<b>Averages</b>	1.00	7.79

Heat Output: 18,501

Heat Input: 25,305

Ultimate CO2

CO2-ult 19.64

Burn Duration: 2.5

Fo

1.061

Burn Rate: 3.0

Stack Temp: 341.7

INPUT DATA				Oxygen Calculation			Input Data		Combust	Heat
Elapsed Time	Weight Remaining (kg)	% CO [e]	% CO2 [d]	Excess Air EA	Total O2	Calc. % O2 [g]	Flue Gas (°C)	Room Temp (°C)	Eff %	Transfer %
0	4.08	1.12	1.85	561.4%	20.74	18.33	94.4	22.2	71.1%	66.2%
10	3.68	0.50	8.34	122.2%	20.36	11.77	174.4	21.7	95.6%	76.9%
20	2.86	0.32	13.95	37.7%	20.00	5.89	260.0	21.7	98.2%	76.7%
30	2.13	0.50	16.15	18.0%	19.84	3.44	277.2	22.2	97.5%	77.3%
40	1.41	0.98	16.72	11.0%	19.77	2.56	285.0	22.2	95.4%	77.1%
50	1.00	0.08	12.18	60.2%	20.13	7.91	236.1	22.8	99.6%	76.9%
60	0.73	0.20	8.44	127.3%	20.37	11.83	192.2	22.8	98.4%	75.8%
70	0.64	0.75	6.66	165.1%	20.45	13.42	160.6	22.8	92.0%	75.6%
80	0.50	1.14	5.80	183.0%	20.48	14.11	145.6	22.8	86.9%	75.3%
90	0.45	1.51	5.63	175.1%	20.47	14.08	133.9	22.8	83.1%	76.0%
100	0.36	1.44	5.17	197.2%	20.50	14.61	125.0	22.8	82.6%	76.1%
110	0.32	1.34	4.99	210.3%	20.52	14.86	116.7	23.3	83.1%	76.8%
120	0.23	1.42	5.09	201.7%	20.51	14.71	122.8	23.3	82.6%	76.3%
130	0.14	1.54	4.85	207.4%	20.52	14.90	121.7	23.3	80.8%	75.8%
140	0.09	1.56	4.44	227.4%	20.54	15.32	117.2	23.3	79.3%	75.3%

150  
0

0.05

1.62

4.44

224.1%

20.54

15.29

112.2

23.3

78.8%

75.9%

	Air Fuel Ratio (A/F)		
73.1%	Dry Molecular Weight (Md)	29.73	
95.1%	Dry Moles Exhaust Gas (Nr):	420.17	%HC
76.9%	Air Fuel Ratio (A/F)	11.98	1.32

Combustion Efficiency: 95.1%  
 Total Input (kJ): 66,689  
 Total Output (kJ): 48,759  
 Efficiency: 73.1%  
 Total CO (g): 234.71

Btu/h 19,504 kJ/h  
 Btu/h 26,676 kJ/h

h

lb/h 1.3 kg/h

Deg. F 172.0 Deg. C

66.5%	15.8	1.17	71.46	0.02	71.46	66319	4.06	6.87	2.74	19810.00	17.56
Net Eff %	Air Fuel Ratio	Wet Wt Now Wt	% Wet Consumed x	Dry Wt. Now Wtdn	% Dry Comsumed y	Fuel Properties			Oxygen /16= [c]	Calorific Value	Mw Moisture Fuel Burnt
						Total Input	Carbon /12= [a]	Hydrogen /1= [b]			
47.0%	37.8	4.08	0.00	3.37	0.00	0	4.06	6.87	2.74	19810.00	17.56
73.6%	13.3	3.68	10.00	3.03	10.00	13338	4.06	6.87	2.74	19810.00	17.56
75.4%	8.3	2.86	30.00	2.36	30.00	12597	4.06	6.87	2.74	19810.00	17.56
75.4%	7.1	2.13	47.78	1.76	47.78	11856	4.06	6.87	2.74	19810.00	17.56
73.5%	6.7	1.41	65.56	1.16	65.56	9262	4.06	6.87	2.74	19810.00	17.56
76.6%	9.7	1.00	75.56	0.82	75.56	5557	4.06	6.87	2.74	19810.00	17.56
74.6%	13.7	0.73	82.22	0.60	82.22	2964	4.06	6.87	2.74	19810.00	17.56
69.5%	15.7	0.64	84.44	0.52	84.44	1852	4.06	6.87	2.74	19810.00	17.56
65.4%	16.6	0.50	87.78	0.41	87.78	1482	4.06	6.87	2.74	19810.00	17.56
63.1%	16.0	0.45	88.89	0.37	88.89	1111	4.06	6.87	2.74	19810.00	17.56
62.9%	17.3	0.36	91.11	0.30	91.11	1111	4.06	6.87	2.74	19810.00	17.56
63.9%	18.1	0.32	92.22	0.26	92.22	1111	4.06	6.87	2.74	19810.00	17.56
63.0%	17.5	0.23	94.44	0.19	94.44	1482	4.06	6.87	2.74	19810.00	17.56
61.2%	17.8	0.14	96.67	0.11	96.67	1111	4.06	6.87	2.74	19810.00	17.56
59.7%	18.9	0.09	97.78	0.07	97.78	741	4.06	6.87	2.74	19810.00	17.56

59.8% 18.7 0.05 98.89 0.04 98.89 741 4.06 6.87 2.74 19810.00 17.56  
0.00

Moisture Content MCwb: 17.56

63,251	(Btu)	Moisture of Wood (wet basis):	17.56	Dry kg :	3.37
46,245	(Btu)	Initial Dry Weight Wtdo (kg):	3.37	CA:	48.73
		Moisture Content Dry	21.30	HY:	6.87
				OX:	43.90

Load Weight (kg):	4.08				
Fuel Heating:	HHV	LHV		HHV	LHV
Value in kJ/kg - CV:	19810.00	18328.69	Btu/lb	8522.48	7885.21

79.14	20.99	2.20	7.29	0.13	0.22	33.94	75.27	6.11	0.77	433.40	32.98
Mass Balance (moles/100 mole dry flue gas)					kg Wood per 100 mole dfp Nk	Moles per kg of Dry Wood					
[h]	[u]	[w]	[j]	[k]		CO2	O2	CO	HC	N2	H2O
78.70	20.87	0.76	2.36	0.13	0.08	24.33	241.08	14.73	1.76	1034.80	31.00
79.39	21.06	2.19	7.42	0.05	0.22	38.27	53.99	2.29	0.25	364.32	34.03
79.84	21.18	3.52	12.03	0.04	0.35	39.79	16.80	0.91	0.11	227.76	34.31
79.91	21.20	4.12	14.01	0.07	0.41	39.43	8.40	1.22	0.16	195.08	34.19
79.74	21.15	4.39	14.81	0.14	0.44	38.25	5.86	2.24	0.32	182.43	33.89
79.83	21.17	3.02	10.37	0.00	0.30	40.55	26.34	0.27	0.00	265.77	34.53
79.53	21.10	2.13	7.30	0.01	0.21	39.82	55.81	0.94	0.05	375.24	34.43
79.17	21.00	1.85	6.17	0.09	0.18	36.25	73.03	4.08	0.48	430.97	33.57
78.95	20.94	1.74	5.70	0.14	0.17	33.42	81.31	6.57	0.83	454.87	32.87
78.78	20.90	1.81	5.81	0.20	0.18	31.32	78.34	8.40	1.10	438.17	32.33
78.78	20.90	1.67	5.38	0.19	0.17	31.05	87.75	8.65	1.12	473.05	32.28
78.81	20.90	1.60	5.16	0.17	0.16	31.32	93.30	8.41	1.08	494.71	32.37
78.78	20.90	1.65	5.30	0.18	0.16	31.04	89.69	8.66	1.12	480.36	32.29
78.71	20.88	1.62	5.17	0.20	0.16	30.03	92.26	9.54	1.24	487.43	32.04
78.68	20.87	1.53	4.84	0.20	0.15	29.21	100.83	10.26	1.33	517.67	31.85

78.65

20.86

1.54

4.88

0.21

0.15

28.89

99.50

10.54

1.38

511.82

31.77

11.83	440.34	5865.34	4365.19	4232.81	4188.42	5753.35	5061.42	295.86	3362.54	3933.66	27956.79
Moisture Present	Stack Temp K	Heat Content Change - Ambient to Stack Temperature						Room Temp K	Energy		
		Flue Gas Constituent							CO2	O2	CO
		CO2	O2	CO	N2	CH4	H2O		CO2	O2	CO
11.83	367.59	2827.72	2149.72	2095.77	2071.42	2674.68	2509.61	295.37	68.79	518.25	4198.21
11.83	447.59	6157.70	4602.10	4467.34	4419.48	5997.83	5343.38	294.82	235.66	248.48	659.55
11.83	533.15	9901.68	7271.04	7026.14	6957.59	9927.55	8393.79	294.82	394.02	122.12	264.74
11.83	550.37	10659.84	7799.90	7530.17	7458.19	10748.72	8993.69	295.37	420.29	65.52	354.63
11.83	558.15	11014.61	8047.00	7765.57	7692.01	11133.80	9273.83	295.37	421.34	47.15	651.91
11.83	509.26	8792.58	6486.47	6275.53	6212.71	8750.14	7499.47	295.93	356.54	170.83	77.04
11.83	465.37	6875.86	5118.55	4963.64	4911.52	6741.75	5935.42	295.93	273.80	285.68	271.72
11.83	433.71	5527.60	4142.34	4023.80	3980.11	5359.66	4813.74	295.93	200.39	302.50	1171.74
11.83	418.71	4899.10	3683.07	3580.57	3541.08	4724.58	4284.42	295.93	163.72	299.46	1882.29
11.83	407.04	4414.78	3327.26	3236.70	3200.58	4239.34	3873.61	295.93	138.25	260.64	2404.02
11.83	398.15	4048.42	3056.99	2975.22	2941.71	3874.75	3561.13	295.93	125.69	268.26	2472.83
11.83	389.82	3685.86	2787.90	2714.47	2683.66	3517.49	3249.40	296.48	115.46	260.10	2403.31
11.83	395.93	3936.01	2973.18	2893.91	2861.26	3764.82	3463.89	296.48	122.16	266.68	2475.33
11.83	394.82	3890.45	2939.46	2861.27	2828.95	3719.69	3424.87	296.48	116.85	271.19	2726.08
11.83	390.37	3708.56	2804.73	2730.78	2699.80	3539.89	3268.89	296.48	108.34	282.79	2932.78

11.83 385.37 3504.61 2653.36 2584.11 2554.64 3338.93 3093.54 296.48 101.26 264.01 3010.62



SUMS				AVERAGE	SUMS					
24596.73	11005.04	25909.05	9283.17	6627.94	17930	3292	14638.45	48388	3292	234.71
Flue Gas Constituent				Total Loss Rate	Total Loss	Chemical Loss 1	Sensible and Latent Loss	Total Output	Chem Loss 2	Grams Pro CO
N2	CH4	H2O Comb	H2O Fuel MC							
2143.51	1570.41	1441.06	550.00	10490.22	0	0	0.00	0	0	0.00
1610.10	221.87	1677.97	583.53	5237.17	3526	586	2940.57	9812	586	43.25
1584.64	95.44	1796.60	619.63	4877.19	3101	224	2877.03	9496	224	16.25
1454.98	148.13	1810.99	626.73	4881.26	2921	294	2627.00	8935	294	20.46
1403.26	286.07	1804.28	630.05	5244.06	2452	429	2023.15	6810	429	29.35
1651.14	-3.19	1777.19	609.05	4638.60	1301	20	1281.04	4256	20	2.09
1842.98	42.83	1718.06	590.54	5025.62	752	46	705.62	2212	46	3.95
1715.30	427.70	1637.51	577.27	6032.40	564	148	416.31	1288	148	10.69
1610.73	739.74	1586.06	571.00	6853.00	513	194	318.57	969	194	13.76
1402.40	982.29	1546.56	566.14	7300.31	410	188	221.39	702	188	13.19
1391.59	1000.69	1534.46	562.44	7355.97	413	193	219.52	699	193	13.58
1327.65	961.66	1528.48	558.76	7155.41	401	187	214.16	710	187	13.21
1374.43	999.24	1531.46	561.29	7330.60	548	258	290.66	934	258	18.14
1378.92	1109.93	1518.46	560.83	7682.26	431	213	217.59	680	213	14.98
1397.60	1192.20	1504.74	558.99	7977.44	298	153	145.33	443	153	10.75

1307.52 1230.02 1495.14 556.91 7965.49 298 157 140.52 443 157 11.04

16.53
roduced HC

- 0.00
- 2.67
- 1.08
- 1.57
- 2.37
- 0.02
- 0.11
- 0.71
- 0.99
- 0.99
- 1.00
- 0.97
- 1.34
- 1.11
- 0.80

0.82

## Dirigo Laboratories, Inc.

**Manufacturer:** New Buck Corporation  
**Model:** 21NC  
**Date:** 8/18/2016  
**Run:** 3  
**Control #:** 037-S-048-6B  
**Test Duration:** 150  
**Output Category:** 3

	HHV Basis	LHV Basis
Overall Efficiency	73.1%	79.0%
Combustion Efficiency	95.1%	95.1%
Heat Transfer Efficiency	76.9%	83.1%

HHV Output Rate (kJ/h)	19,504	18,501	(Btu/h)
Burn Rate (kg/h)	1.35	2.97	(lb/h)
Input (kJ/h)	26,676	25,305	(Btu/h)

Test Load Weight (dry kg)	3.4	7.4	dry lb
MC wet (%)	17.56		
MC dry (%)	21.30		
Particulate (g)	4.33		
CO (g)	235		
Test Duration (h)	2.5		

Emissions	Particulate	CO
g/MJ Output	0.09	4.81
g/kg Dry Fuel	1.29	69.72
g/h	1.73	93.88
lb/MM Btu Output	0.21	11.19

Air/Fuel Ratio (A/F)	11.98
----------------------	-------

Test Results in Accordance with CSA B415.1-10

### Default Fuel Values

	<b>D. Fir</b>	<b>Oak</b>
<b>HHV (kJ/kg)</b>	19,810	19,887
<b>%C</b>	48.73	50
<b>%H</b>	6.87	6.6
<b>%O</b>	43.9	42.9
<b>%Ash</b>	0.5	0.5

VERSION: 2.4

4/15/2010

Manufacturer: New Buck Corporation

Model: 21NC

Date: 8/18/2016

Run: 4

Control #: 037-S-048-6B

Test Duration: 90

Burn Category: 4

Wood Moisture (% DRY): 20.4

Wood Moisture (% wet): 16.94

Load Weight (lb wet): 8.90

Burn Rate (dry kg/h): 2.24

Total Particulate Emissions: 3.45 g

Appliance Type: Non-Cat (Cat, Non-Cat, Pe

Temp. Units: F (F or C)

Weight Units: lb (kg or lb)

Fuel Data

D. Fir

HHV: 19,810 kJ/kg

%C: 48.73

%H: 6.87

%O: 43.90

%Ash: 0.50

Averages

518.5

76.7

13.01

7.03

0.55

Temp. (F)

Elapsed Time (min)	Fuel Weight Remaining (lb)	Flue Gas Temp. (F)	Flue Gas Composition (%)		
			O2	CO2	CO
0	8.9	323.0	17.38	2.37	0.95
10	7.0	775.0	6.69	14.01	0.10
20	4.4	750.0	8.33	12.46	0.05
30	2.5	731.0	7.88	12.52	0.03
40	1.4	618.0	11.87	8.45	0.09
50	0.9	491.0	14.37	5.67	0.48
60	0.6	422.0	15.40	4.30	0.88
70	0.4	388.0	15.57	4.13	0.92
80	0.2	356.0	16.08	3.47	1.00
90	0.0	331.0	16.52	2.95	1.00

let)

- Dougl
- Oak



Manufacturer: aw Buck Corporation

Model: 21NC

Date: 8/18/2016

Run: 4

Control #: 037-S-048-6B

Test Duration: 90 min

Overall Heating Efficiency:

Combustion Efficiency:

Heat Transfer Efficiency:

	HHV	LHV
Eff	65.2%	70.5%
Comb Eff	98.0%	98.0%
HT Eff	66.6%	72.0%
Output	28,901	kJ/h
Burn Rate	2.24	kg/h
Grams CO	104	g
Input	44,294	kJ/h
MC wet	16.94	
<b>Averages</b>	0.55	7.03

Heat Output: 27,416

Heat Input: 42,018

Ultimate CO2

CO2-ult 19.64

Burn Duration: 1.5

Fo

1.061

Burn Rate: 4.9

Stack Temp: 540.2

INPUT DATA				Oxygen Calculation			Input Data		Combust	Heat
Elapsed Time	Weight Remaining (kg)	% CO [e]	% CO2 [d]	Excess Air EA	Total O2	Calc. % O2 [g]	Flue Gas (°C)	Room Temp (°C)	Eff %	Transfer %
0	4.04	0.95	2.37	491.7%	20.72	17.88	161.7	23.9	78.0%	55.1%
10	3.18	0.10	14.01	39.2%	20.01	5.95	412.8	23.9	99.5%	68.5%
20	2.00	0.05	12.46	57.0%	20.11	7.63	398.9	24.4	99.8%	67.2%
30	1.13	0.03	12.52	56.5%	20.11	7.58	388.3	24.4	100.0%	68.0%
40	0.64	0.09	8.45	130.0%	20.38	11.88	325.6	25.0	99.5%	64.9%
50	0.41	0.48	5.67	219.4%	20.53	14.62	255.0	25.0	94.1%	62.9%
60	0.27	0.88	4.30	279.2%	20.60	15.86	216.7	25.0	86.7%	61.2%
70	0.18	0.92	4.13	289.0%	20.61	16.02	197.8	25.6	85.8%	63.2%
80	0.09	1.00	3.47	339.4%	20.64	16.67	180.0	25.6	82.5%	61.9%
90	0.00	1.00	2.95	397.3%	20.68	17.23	166.1	25.6	80.3%	60.5%

	Air Fuel Ratio (A/F)	
65.2%	Dry Molecular Weight (Md)	29.65
98.0%	Dry Moles Exhaust Gas (Nr):	477.37
66.6%	Air Fuel Ratio (A/F)	13.64

%HC  
1.32

Combustion Efficiency: 98.0%  
 Total Input (kJ): 66,441  
 Total Output (kJ): 43,351  
 Efficiency: 65.2%  
 Total CO (g): 104.19

Btu/h 28,901 kJ/h  
 Btu/h 44,294 kJ/h

h

lb/h 2.2 kg/h

Deg. F 282.3 Deg. C

57.7%	19.4	1.19	70.45	0.01	70.45	67188	4.06	6.87	2.74	19810.00	16.94
Net Eff %	Air Fuel Ratio	Wet Wt Now Wt	% Wet Consumed x	Dry Wt. Now Wtdn	% Dry Comsumed y	Fuel Properties			Oxygen /16= [c]	Calorific Value	Mw Moisture Fuel Burnt
						Total Input	Carbon /12= [a]	Hydrogen /1= [b]			
43.0%	34.2	4.04	0.00	3.35	0.00	0	4.06	6.87	2.74	19810.00	16.94
68.1%	8.4	3.18	21.35	2.64	21.35	23889	4.06	6.87	2.74	19810.00	16.94
67.1%	9.5	2.00	50.56	1.66	50.56	16797	4.06	6.87	2.74	19810.00	16.94
68.0%	9.5	1.13	71.91	0.94	71.91	11198	4.06	6.87	2.74	19810.00	16.94
64.6%	13.9	0.64	84.27	0.53	84.27	5972	4.06	6.87	2.74	19810.00	16.94
59.2%	19.0	0.41	89.89	0.34	89.89	2986	4.06	6.87	2.74	19810.00	16.94
53.1%	22.3	0.27	93.26	0.23	93.26	1866	4.06	6.87	2.74	19810.00	16.94
54.2%	22.8	0.18	95.51	0.15	95.51	1493	4.06	6.87	2.74	19810.00	16.94
51.1%	25.6	0.09	97.75	0.08	97.75	2240	4.06	6.87	2.74	19810.00	16.94
48.6%	28.9	0.00	100.00	0.00	100.00	747	4.06	6.87	2.74	19810.00	16.94

Moisture Content MCwb: 16.94

63,016	(Btu)	Moisture of Wood (wet basis):	16.94	Dry kg :	3.35
41,117	(Btu)	Initial Dry Weight Wtdo (kg):	3.35	CA:	48.73
		Moisture Content Dry	20.40	HY:	6.87
				OX:	43.90

Load Weight (kg):	4.04				
Fuel Heating:	HHV	LHV		HHV	LHV
Value in kJ/kg - CV:	19810.00	18328.69	Btu/lb	8522.48	7885.21

79.29	21.03	1.88	6.35	0.06	0.19	35.42	100.30	4.85	0.54	531.84	33.43
Mass Balance (moles/100 mole dry flue gas)					kg Wood per 100 mole dfp Nk	Moles per kg of Dry Wood					
[h]	[u]	[w]	[j]	[k]		CO2	O2	CO	HC	N2	H2O
78.80	20.90	0.84	2.68	0.11	0.08	28.20	212.72	11.30	1.31	937.74	31.91
79.94	21.20	3.48	11.93	0.01	0.35	40.51	17.20	0.29	0.01	231.14	34.49
79.86	21.18	3.08	10.59	0.00	0.31	40.67	24.90	0.16	-0.02	260.64	34.56
79.87	21.19	3.09	10.62	-0.01	0.31	40.74	24.65	0.10	-0.03	259.91	34.57
79.58	21.11	2.10	7.23	-0.01	0.21	40.41	56.82	0.43	-0.03	380.57	34.58
79.23	21.01	1.53	5.15	0.05	0.15	37.35	96.32	3.16	0.31	521.82	33.91
78.96	20.94	1.30	4.26	0.10	0.13	33.22	122.51	6.80	0.79	610.03	32.93
78.93	20.94	1.27	4.15	0.11	0.13	32.68	126.72	7.28	0.86	624.52	32.81
78.86	20.92	1.13	3.64	0.12	0.11	30.86	148.30	8.89	1.06	701.31	32.41
78.82	20.91	1.00	3.21	0.12	0.10	29.60	172.85	10.03	1.18	790.76	32.15

11.33	543.43	10379.81	7544.68	7271.06	7204.24	10576.55	8680.14	297.98	3877.29	5655.97	13943.98
Moisture Present	Stack Temp K	Heat Content Change - Ambient to Stack Temperature						Room Temp K	Energ		
		Flue Gas Constituent							CO2	O2	CO
		CO2	O2	CO	N2	CH4	H2O		CO2	O2	CO
11.33	434.82	5532.04	4143.71	4024.65	3981.05	5368.23	4814.62	297.04	156.02	881.43	3244.14
11.33	685.93	17030.62	12135.41	11633.34	11539.58	17886.58	13867.95	297.04	689.89	208.72	85.19
11.33	672.04	16325.66	11662.20	11187.27	11095.49	17082.43	13338.63	297.59	663.89	290.37	48.01
11.33	661.48	15809.75	11316.16	10861.14	10770.80	16493.33	12951.67	297.59	644.09	278.98	28.69
11.33	598.71	12786.96	9262.48	8918.44	8838.21	13099.10	10644.19	298.15	516.73	526.29	125.64
11.33	528.15	9549.91	7015.08	6779.40	6713.13	9569.70	8099.21	298.15	356.64	675.69	916.11
11.33	489.82	7851.72	5812.84	5628.93	5571.50	7769.03	6728.40	298.15	260.83	712.14	1962.20
11.33	470.93	7009.39	5208.92	5049.03	4996.49	6892.46	6036.81	298.71	229.04	660.08	2096.65
11.33	453.15	6246.03	4658.87	4520.16	4472.21	6104.10	5405.83	298.71	192.76	690.91	2557.04
11.33	439.26	5656.03	4231.12	4108.20	4063.98	5500.51	4914.13	298.71	167.39	731.35	2880.32

SUMS				AVERAGE	SUMS					
31827.69	4884.47	17636.37	5966.95	8379.27	23090	1347	21742.64	44098	1347	104.19
Flue Gas Constituent				Total Loss Rate	Total Loss	Chemical Loss 1	Sensible and Latent Loss	Total Output	Chem Loss 2	Grams Pro CO
N2	CH4	H2O Comb	H2O Fuel MC							
3733.20	1169.23	1556.75	552.89	11293.65	0	0	0.00	0	0	0.00
2667.31	13.15	1995.01	655.49	6314.75	7615	114	7500.76	16274	114	9.76
2891.94	-14.76	1980.27	649.49	6509.21	5519	27	5492.28	11278	27	3.87
2799.44	-23.06	1967.95	645.11	6341.19	3584	3	3581.64	7613	3	1.55
3363.58	-25.90	1888.52	618.95	7013.81	2114	29	2085.47	3858	29	3.63
3503.02	275.21	1765.68	590.11	8082.46	1218	176	1042.43	1768	176	13.34
3398.77	712.87	1669.71	574.58	9291.09	875	248	627.49	991	248	17.93
3120.38	768.92	1640.60	566.74	9082.42	685	213	471.77	809	213	15.36
3136.40	948.08	1600.09	559.59	9684.87	1095	391	703.92	1145	391	28.15
3213.65	1060.74	1571.79	554.01	10179.26	384	147	236.88	363	147	10.59

5.29
roduced HC

- 0.00
- 0.28
- 0.22
- 0.23
- 0.14
- 0.74
- 1.20
- 1.03
- 1.91
- 0.71

## Dirigo Laboratories, Inc.

**Manufacturer:** New Buck Corporation  
**Model:** 21NC  
**Date:** 8/18/2016  
**Run:** 4  
**Control #:** 037-S-048-6B  
**Test Duration:** 90  
**Output Category:** 4

	HHV Basis	LHV Basis
Overall Efficiency	65.2%	70.5%
Combustion Efficiency	98.0%	98.0%
Heat Transfer Efficiency	66.6%	72.0%

HHV Output Rate (kJ/h)	28,901	27,416	(Btu/h)
Burn Rate (kg/h)	2.24	4.93	(lb/h)
Input (kJ/h)	44,294	42,018	(Btu/h)

Test Load Weight (dry kg)	3.4	7.4	dry lb
MC wet (%)	16.94		
MC dry (%)	20.40		
Particulate (g)	3.45		
CO (g)	104		
Test Duration (h)	1.5		

Emissions	Particulate	CO
g/MJ Output	0.08	2.40
g/kg Dry Fuel	1.03	31.07
g/h	2.30	69.46
lb/MM Btu Output	0.18	5.59

Air/Fuel Ratio (A/F)	13.64
----------------------	-------

Test Results in Accordance with CSA B415.1-10

### Default Fuel Values

	<b>D. Fir</b>	<b>Oak</b>
<b>HHV (kJ/kg)</b>	19,810	19,887
<b>%C</b>	48.73	50
<b>%H</b>	6.87	6.6
<b>%O</b>	43.9	42.9
<b>%Ash</b>	0.5	0.5



VERSION: 2.4

4/15/2010

Manufacturer: New Buck Corporation

Appliance Type: Non-Cat (Cat, Non-Cat, Pe

Model: 21NC

Date: 8/18/2016

Run: 5

Temp. Units: F (F or C)

Weight Units: lb (kg or lb)

Control #: 037-S-048-6B

Test Duration: 210

Burn Category: 2

Wood Moisture (% DRY): 19.2

Wood Moisture (% wet): 16.11

Load Weight (lb wet): 9.20

Burn Rate (dry kg/h): 1.00

Total Particulate Emissions: 8.84 g

Fuel Data	
	D. Fir
HHV	19,810 kJ/kg
%C	48.73
%H	6.87
%O	43.90
%Ash	0.50

Elapsed Time (min)	Averages Fuel Weight Remaining (lb)	294.8 Flue Gas	79.8 Room Temp (F)	12.80 6.80 1.26 Flue Gas Composition (%)		
				O2	CO2	CO
0	9.2	251.0	77.0	16.44	3.28	1.00
10	8.3	296.0	77.0	17.07	2.87	0.59
20	7.8	243.0	78.0	15.83	4.34	0.90
30	6.6	403.0	78.0	9.62	11.15	0.59
40	5.3	465.0	78.0	6.17	14.57	0.70
50	3.9	496.0	79.0	4.22	16.05	1.24
60	2.7	479.0	79.0	5.90	14.33	0.29
70	2.0	408.0	80.0	9.80	10.51	0.04
80	1.7	347.0	80.0	12.42	7.52	0.38
90	1.5	303.0	80.0	13.28	6.30	1.10
100	1.4	280.0	80.0	13.18	6.28	1.24
110	1.2	268.0	80.0	13.27	6.13	1.38
120	1.1	253.0	81.0	13.80	5.34	1.72
130	0.9	242.0	80.0	13.85	5.13	2.01
140	0.8	235.0	81.0	14.02	4.99	1.96
150	0.7	232.0	81.0	13.81	5.25	1.94
160	0.5	226.0	81.0	14.29	4.67	2.04
170	0.4	220.0	81.0	14.61	4.33	1.96
180	0.3	216.0	81.0	14.87	4.14	1.87
190	0.2	212.0	81.0	14.80	4.33	1.70
200	0.1	208.0	81.0	15.02	4.21	1.46
210	0.0	203.0	81.0	15.34	3.79	1.59

allet)

- Dougla
- Oak

Manufacturer: aw Buck Corporation

Model: 21NC

Date: 8/18/2016

Run: 5

Control #: 037-S-048-6B

Test Duration: 210 min

Overall Heating Efficiency:

Combustion Efficiency:

Heat Transfer Efficiency:

	HHV	LHV
Eff	69.5%	75.2%
Comb Eff	91.4%	91.4%
HT Eff	76.1%	82.2%
Output	13,782	kJ/h
Burn Rate	1.00	kg/h
Grams CO	427	g
Input	19,821	kJ/h
MC wet	16.11	
<b>Averages</b>	1.26	6.80

Heat Output: 13,073

Heat Input: 18,802

Ultimate CO2

CO2-ult 19.64

Burn Duration: 3.5

Fo

1.061

Burn Rate: 2.2

Stack Temp: 296.9

INPUT DATA				Oxygen Calculation			Input Data		Combust	Heat
Elapsed Time	Weight Remaining (kg)	% CO [e]	% CO2 [d]	Excess Air EA	Total O2	Calc. % O2 [g]	Flue Gas (°C)	Room Temp (°C)	Eff %	Transfer %
0	4.17	1.00	3.28	358.9%	20.66	16.88	121.7	25.0	81.8%	71.2%
10	3.77	0.59	2.87	467.7%	20.71	17.55	146.7	25.0	87.2%	63.7%
20	3.54	0.90	4.34	274.9%	20.59	15.80	117.2	25.6	86.6%	76.0%
30	2.99	0.59	11.15	67.3%	20.16	8.72	206.1	25.6	96.0%	78.2%
40	2.40	0.70	14.57	28.6%	19.93	5.01	240.6	25.6	96.2%	78.6%
50	1.77	1.24	16.05	13.6%	19.80	3.13	257.8	26.1	94.0%	78.5%
60	1.23	0.29	14.33	34.4%	19.97	5.50	248.3	26.1	98.4%	78.2%
70	0.91	0.04	10.51	86.2%	20.24	9.71	208.9	26.7	99.9%	77.6%
80	0.77	0.38	7.52	148.6%	20.42	12.71	175.0	26.7	96.4%	76.5%
90	0.68	1.10	6.30	165.4%	20.45	13.60	150.6	26.7	88.1%	76.5%
100	0.64	1.24	6.28	161.2%	20.44	13.54	137.8	26.7	86.8%	77.7%
110	0.54	1.38	6.13	161.6%	20.44	13.62	131.1	26.7	85.3%	78.0%
120	0.50	1.72	5.34	178.2%	20.47	14.27	122.8	27.2	80.5%	77.4%
130	0.41	2.01	5.13	175.1%	20.47	14.33	116.7	26.7	77.5%	77.5%
140	0.36	1.96	4.99	182.6%	20.48	14.51	112.8	27.2	77.5%	77.8%

150	0.32	1.94	5.25	173.2%	20.47	14.25	111.1	27.2	78.4%	78.5%
160	0.23	2.04	4.67	192.7%	20.50	14.81	107.8	27.2	75.8%	77.7%
170	0.18	1.96	4.33	212.3%	20.52	15.21	104.4	27.2	75.2%	77.4%
180	0.14	1.87	4.14	226.8%	20.54	15.47	102.2	27.2	75.3%	77.3%
190	0.09	1.70	4.33	225.8%	20.54	15.36	100.0	27.2	77.6%	78.1%
200	0.05	1.46	4.21	246.4%	20.57	15.63	97.8	27.2	79.6%	78.3%
210	0.00	1.59	3.79	265.1%	20.58	16.00	95.0	27.2	76.6%	77.6%

	Air Fuel Ratio (A/F)	
69.5%	Dry Molecular Weight (Md)	29.61
91.4%	Dry Moles Exhaust Gas (Nr):	453.33
76.1%	Air Fuel Ratio (A/F)	12.91

%HC  
1.32

Combustion Efficiency: 91.4%  
 Total Input (kJ): 69,372  
 Total Output (kJ): 48,236  
 Efficiency: 69.5%  
 Total CO (g): 427.44

Btu/h 13,782 kJ/h  
 Btu/h 19,821 kJ/h

h

lb/h 1.0 kg/h

Deg. F 147.2 Deg. C

65.3%	16.5	1.17	72.04	0.02	72.04	69749	4.06	6.87	2.74	19810.00	16.11
Net Eff %	Air Fuel Ratio	Wet Wt Now Wt	% Wet Consumed x	Dry Wt. Now Wtdn	% Dry Comsumed y	Fuel Properties			Oxygen /16= [c]	Calorific Value	Mw Moisture Fuel Burnt
						Total Input	Carbon /12= [a]	Hydrogen /1= [b]			
58.2%	26.7	4.17	0.00	3.50	0.00	0	4.06	6.87	2.74	19810.00	16.11
55.6%	33.4	3.77	9.78	3.16	9.78	8672	4.06	6.87	2.74	19810.00	16.11
65.8%	22.0	3.54	15.22	2.97	15.22	6409	4.06	6.87	2.74	19810.00	16.11
75.0%	10.0	2.99	28.26	2.51	28.26	9426	4.06	6.87	2.74	19810.00	16.11
75.7%	7.7	2.40	42.39	2.02	42.39	10180	4.06	6.87	2.74	19810.00	16.11
73.8%	6.8	1.77	57.61	1.48	57.61	9803	4.06	6.87	2.74	19810.00	16.11
77.0%	8.1	1.23	70.65	1.03	70.65	7163	4.06	6.87	2.74	19810.00	16.11
77.6%	11.3	0.91	78.26	0.76	78.26	3770	4.06	6.87	2.74	19810.00	16.11
73.7%	14.9	0.77	81.52	0.65	81.52	1885	4.06	6.87	2.74	19810.00	16.11
67.4%	15.6	0.68	83.70	0.57	83.70	1131	4.06	6.87	2.74	19810.00	16.11
67.4%	15.3	0.64	84.78	0.53	84.78	1131	4.06	6.87	2.74	19810.00	16.11
66.5%	15.3	0.54	86.96	0.46	86.96	1131	4.06	6.87	2.74	19810.00	16.11
62.3%	16.1	0.50	88.04	0.42	88.04	1131	4.06	6.87	2.74	19810.00	16.11
60.1%	15.8	0.41	90.22	0.34	90.22	1131	4.06	6.87	2.74	19810.00	16.11
60.3%	16.2	0.36	91.30	0.30	91.30	754	4.06	6.87	2.74	19810.00	16.11

61.5%	15.7	0.32	92.39	0.27	92.39	1131	4.06	6.87	2.74	19810.00	16.11
58.9%	16.7	0.23	94.57	0.19	94.57	1131	4.06	6.87	2.74	19810.00	16.11
58.2%	17.8	0.18	95.65	0.15	95.65	754	4.06	6.87	2.74	19810.00	16.11
58.2%	18.7	0.14	96.74	0.11	96.74	754	4.06	6.87	2.74	19810.00	16.11
60.6%	18.7	0.09	97.83	0.08	97.83	754	4.06	6.87	2.74	19810.00	16.11
62.3%	20.0	0.05	98.91	0.04	98.91	1131	4.06	6.87	2.74	19810.00	16.11
59.4%	21.0	0.00	100.00	0.00	100.00	377	4.06	6.87	2.74	19810.00	16.11

Moisture Content MCwb: 16.11

65,796	(Btu)	Moisture of Wood (wet basis):	16.11	Dry kg :	3.50
45,750	(Btu)	Initial Dry Weight Wtdo (kg):	3.50	CA:	48.73
		Moisture Content Dry	19.20	HY:	6.87
				OX:	43.90

Load Weight (kg):	4.17				
Fuel Heating:	HHV	LHV		HHV	LHV
Value in kJ/kg - CV:	19810.00	18328.69	Btu/lb	8522.48	7885.21

78.96	20.94	2.02	6.63	0.16	0.20	32.39	81.59	7.46	0.96	453.28	32.61
Mass Balance (moles/100 mole dry flue gas)					kg Wood per 100 mole dfp Nk	Moles per kg of Dry Wood					
[h]	[u]	[w]	[j]	[k]		CO2	O2	CO	HC	N2	H2O
78.84	20.91	1.08	3.48	0.12	0.11	30.43	156.60	9.28	1.10	731.54	32.32
78.99	20.95	0.87	2.86	0.06	0.09	33.30	203.57	6.85	0.67	916.46	33.18
78.96	20.94	1.32	4.31	0.11	0.13	33.13	120.66	6.87	0.81	602.79	32.91
79.54	21.10	2.91	9.85	0.07	0.29	38.53	30.13	2.04	0.25	274.82	34.03
79.72	21.15	3.78	12.81	0.09	0.38	38.70	13.31	1.86	0.25	211.76	34.02
79.58	21.11	4.30	14.42	0.18	0.43	37.50	7.31	2.90	0.41	185.96	33.70
79.88	21.19	3.61	12.33	0.03	0.36	39.91	15.32	0.81	0.09	222.48	34.34
79.74	21.15	2.60	8.94	-0.01	0.26	40.70	37.61	0.15	-0.04	308.75	34.60
79.39	21.06	1.95	6.64	0.03	0.19	38.68	65.36	1.95	0.18	408.34	34.16
79.00	20.95	1.86	6.10	0.14	0.18	34.11	73.64	5.96	0.75	427.69	33.02
78.94	20.94	1.89	6.18	0.16	0.19	33.38	71.98	6.59	0.84	419.53	32.83
78.87	20.92	1.89	6.15	0.18	0.19	32.54	72.31	7.32	0.95	418.60	32.62
78.67	20.87	1.79	5.71	0.23	0.18	29.90	79.94	9.63	1.28	440.54	31.97
78.53	20.83	1.82	5.73	0.27	0.18	28.25	78.95	11.07	1.49	432.51	31.55
78.54	20.83	1.78	5.58	0.26	0.18	28.24	82.11	11.09	1.48	444.43	31.55

78.56	20.84	1.83	5.78	0.26	0.18	28.76	78.04	10.63	1.42	430.40	31.68
78.48	20.82	1.72	5.36	0.27	0.17	27.29	86.53	11.92	1.60	458.66	31.33
78.50	20.82	1.61	5.02	0.26	0.16	26.97	94.78	12.21	1.63	489.00	31.27
78.52	20.83	1.54	4.80	0.25	0.15	27.00	100.88	12.20	1.62	512.12	31.29
78.61	20.85	1.54	4.84	0.22	0.15	28.26	100.26	11.10	1.46	513.06	31.61
78.70	20.88	1.44	4.58	0.19	0.14	29.33	108.87	10.17	1.31	548.36	31.91
78.62	20.85	1.38	4.31	0.21	0.14	27.69	116.90	11.62	1.51	574.41	31.51



10.67	419.16	4812.57	3597.94	3492.87	3455.39	4685.08	4177.92	299.69	3630.31	5354.49	46919.78
Moisture Present	Stack Temp K	Heat Content Change - Ambient to Stack Temperature						Room Temp K	Energy		
		Flue Gas Constituent							CO2	O2	CO
		CO2	O2	CO	N2	CH4	H2O		CO2	O2	CO
10.67	394.82	3826.84	2890.37	2813.22	2781.51	3661.16	3367.28	298.15	116.46	452.62	2651.55
10.67	419.82	4860.65	3651.56	3549.30	3510.29	4693.18	4246.80	298.15	161.85	743.35	1961.39
10.67	390.37	3623.73	2739.26	2666.71	2636.53	3461.81	3192.10	298.71	120.07	330.51	1962.79
10.67	479.26	7370.37	5467.74	5297.56	5242.92	7268.10	6333.20	298.71	283.94	164.73	587.70
10.67	513.71	8883.79	6544.14	6328.90	6266.06	8861.98	7562.49	298.71	343.83	87.12	537.98
10.67	530.93	9632.18	7069.97	6831.05	6764.57	9664.27	8160.47	299.26	361.25	51.68	839.77
10.67	521.48	9209.07	6772.30	6546.69	6482.29	9211.52	7821.80	299.26	367.55	103.73	233.86
10.67	482.04	7448.68	5521.40	5348.44	5293.51	7355.03	6393.68	299.82	303.13	207.67	44.66
10.67	448.15	5990.52	4471.93	4339.69	4293.46	5846.42	5190.29	299.82	231.70	292.30	561.59
10.67	423.71	4959.41	3721.36	3616.05	3576.54	4798.17	4326.33	299.82	169.15	274.03	1706.84
10.67	410.93	4427.31	3331.15	3239.12	3203.26	4263.54	3876.07	299.82	147.77	239.78	1886.38
10.67	404.26	4151.58	3128.15	3042.82	3008.90	3988.23	3641.52	299.82	135.08	226.21	2095.12
10.67	395.93	3787.47	2858.58	2781.78	2750.52	3628.00	3329.49	300.37	113.26	228.50	2752.65
10.67	389.82	3558.57	2689.68	2618.37	2588.75	3400.27	3134.20	299.82	100.55	212.34	3161.91
10.67	385.93	3378.70	2555.57	2488.27	2460.02	3224.37	2978.61	300.37	95.40	209.85	3166.27

10.67	384.26	3310.86	2505.16	2439.40	2411.67	3157.64	2920.19	300.37	95.22	195.50	3033.53
10.67	380.93	3175.41	2404.41	2341.72	2315.01	3024.65	2803.39	300.37	86.66	208.06	3401.74
10.67	377.59	3040.28	2303.76	2244.10	2218.42	2892.29	2686.65	300.37	82.01	218.36	3482.82
10.67	375.37	2950.37	2236.71	2179.06	2154.06	2804.39	2608.87	300.37	79.66	225.65	3477.97
10.67	373.15	2860.61	2169.71	2114.04	2089.74	2716.77	2531.10	300.37	80.84	217.54	3163.40
10.67	370.93	2770.99	2102.76	2049.05	2025.44	2629.42	2453.37	300.37	81.28	228.92	2899.53
10.67	368.15	2659.16	2019.12	1967.85	1945.12	2520.63	2356.25	300.37	73.63	236.03	3310.33

SUMS				AVERAGE	SUMS					
30842.13	18811.65	34579.78	11298.57	6883.49	21136	5978	15158.19	48613	5978	427.44
Flue Gas Constituent				Total Loss Rate	Total Loss	Chemical Loss 1	Sensible and Latent Loss	Total Output	Chem Loss 2	Grams Pro CO
N2	CH4	H2O Comb	H2O Fuel MC							
2034.78	983.70	1529.98	504.92	8274.02	0	0	0.00	0	0	0.00
3217.05	599.79	1599.90	514.31	8797.65	3851	1109	2741.92	4820	1109	83.90
1589.28	721.57	1551.96	503.06	6779.23	2193	862	1331.70	4216	862	62.25
1440.88	223.18	1711.54	536.56	4948.54	2355	380	1974.69	7071	380	27.16
1326.91	224.42	1753.27	549.67	4823.22	2478	385	2093.88	7701	385	26.75
1257.94	369.47	1756.84	556.05	5193.00	2570	587	1983.04	7233	587	40.15
1442.19	83.73	1778.31	552.44	4561.81	1650	113	1536.96	5514	113	8.18
1634.35	-34.05	1742.47	537.21	4435.43	844	2	842.23	2926	2	0.83
1753.20	161.05	1679.44	524.37	5203.64	495	68	427.32	1390	68	5.21
1529.65	670.88	1594.87	515.15	6460.57	369	134	234.55	762	134	9.52
1343.88	755.66	1570.89	510.35	6454.71	369	149	219.11	763	149	10.54
1259.52	850.66	1553.05	507.85	6627.48	378	167	211.70	753	167	11.71
1211.72	1140.00	1512.21	504.52	7462.86	426	220	205.64	705	220	15.40
1119.65	1328.49	1486.07	502.44	7911.44	452	254	197.27	679	254	17.70
1093.30	1326.32	1481.36	500.78	7873.28	300	170	129.91	454	170	11.82

1037.98	1271.77	1485.23	500.16	7619.38	435	244	190.96	696	244	16.99
1061.80	1427.86	1465.16	498.91	8150.20	465	274	191.46	666	274	19.06
1084.82	1453.33	1458.82	497.66	8277.82	315	187	128.42	439	187	13.01
1103.13	1442.57	1457.50	496.83	8283.31	315	186	129.18	439	186	13.00
1072.15	1300.08	1469.89	496.01	7799.91	297	169	128.04	457	169	11.83
1110.67	1167.45	1481.21	495.18	7464.24	426	231	195.36	705	231	16.26
1117.30	1343.74	1459.80	494.14	8034.97	153	88	64.85	224	88	6.19

29.80
roduced HC

0.00

4.69

4.18

1.89

2.05

3.25

0.54

-0.12

0.27

0.68

0.77

0.87

1.17

1.36

0.90

1.30  
1.46  
0.99  
0.98  
0.89  
1.19  
0.46

# Dirigo Laboratories, Inc.

**Manufacturer:** New Buck Corporation  
**Model:** 21NC  
**Date:** 8/18/2016  
**Run:** 5  
**Control #:** 037-S-048-6B  
**Test Duration:** 210  
**Output Category:** 2

	HHV Basis	LHV Basis
Overall Efficiency	69.5%	75.2%
Combustion Efficiency	91.4%	91.4%
Heat Transfer Efficiency	76.1%	82.2%

HHV Output Rate (kJ/h)	13,782	13,073	(Btu/h)
Burn Rate (kg/h)	1.00	2.21	(lb/h)
Input (kJ/h)	19,821	18,802	(Btu/h)

Test Load Weight (dry kg)	3.5	7.7	dry lb
MC wet (%)	16.11		
MC dry (%)	19.20		
Particulate (g)	8.84		
CO (g)	427		
Test Duration (h)	3.5		

Emissions	Particulate	CO
g/MJ Output	0.18	8.86
g/kg Dry Fuel	2.52	122.06
g/h	2.53	122.12
lb/MM Btu Output	0.43	20.59

Air/Fuel Ratio (A/F)	12.91
----------------------	-------

Test Results in Accordance with CSA B415.1-10

### Default Fuel Values

	<b>D. Fir</b>	<b>Oak</b>
<b>HHV (kJ/kg)</b>	19,810	19,887
<b>%C</b>	48.73	50
<b>%H</b>	6.87	6.6
<b>%O</b>	43.9	42.9
<b>%Ash</b>	0.5	0.5



Fuel Load Information

Project Number  
037-S-048-6B

Client  
New Buck Corporation





Date  
8/9/2016

Firebox Volume (ft<sup>3</sup>) 1.4

Assessment No

Longest useable measurement parallel or perpendicular to front of unit. 18.5"

Test Fuel Charge Range 8.8 - 10.8  
Coal bed range (lbs) 1.90 - 2.50

Vol ≤ 1.5 ft <sup>3</sup>	Vol > 1.5 ≤ 3.0 ft <sup>3</sup>	Vol > 3.0 ft <sup>3</sup>
		
		

Fuel Piece Length 16.00 Inches

Run # 1

Test Run Fuel Moisture (db)	Hydronic Heater						AVG (%)	Weight Without Cleats (Lbs)	
	S1	S2	S3	S4	S5	S6		Fuel	
Piece 1	21.9	22.8	21.7				22.1		2.01
Piece 2	21.5	21.9	22.1				21.8		1.98
Piece 3	22.0	22.0	21.2				21.7		2.05
Piece 4	19.0	19.0	19.0				19.0		1.58
Piece 5									
Piece 6									
Piece 7									
Piece 8									
Piece 9									
Piece 10									
Piece 11									
Piece 12									
Piece 13									
Piece 14									
Piece 15									
Spacer Average	19.8							20.9	W/Cleats 9.20

Signature

Date

Fuel Load Information

Project Number  
037-S-048-6B

Client  
New Buck Corporation





Date  
8/10/2016

Firebox Volume (ft<sup>3</sup>) 1.4

Assessment No

Longest useable measurement parallel or perpendicular to front of unit. 18.5"

Test Fuel Charge Range 8.8 - 10.8  
Coal bed range (lbs) 1.90 - 2.50

Vol ≤ 1.5 ft <sup>3</sup>	Vol > 1.5 ≤ 3.0 ft <sup>3</sup>	Vol > 3.0 ft <sup>3</sup>
		
		

Fuel Piece Length 16.00 Inches

Run # 2

Test Run Fuel Moisture (db)	Hydronic Heater						AVG (%)	Weight Without Cleats (Lbs)	
	S1	S2	S3	S4	S5	S6		Fuel	
Piece 1	19.2	19.4	19.9				19.5		1.52
Piece 2	19.1	19.0	19.6				19.2		1.90
Piece 3	19.0	19.1	19.2				19.1		2.14
Piece 4	19.4	19.0	20.1				19.5		2.05
Piece 5									
Piece 6									
Piece 7									
Piece 8									
Piece 9									
Piece 10									
Piece 11									
Piece 12									
Piece 13									
Piece 14									
Piece 15									
Spacer Average	21							19.7	W/Cleats 9.60

Signature

Date

Fuel Load Information

Project Number  
037-S-048-6B

Client  
New Buck Corporation





Date  
8/11/2016

Firebox Volume (ft<sup>3</sup>) 1.4

Assessment No

Longest useable measurement parallel or perpendicular to front of unit. 18.5"

Test Fuel Charge Range 8.8 - 10.8  
Coal bed range (lbs) 1.90 - 2.50

Vol ≤ 1.5 ft <sup>3</sup>	Vol > 1.5 ≤ 3.0 ft <sup>3</sup>	Vol > 3.0 ft <sup>3</sup>
		
		

Fuel Piece Length 16.00 Inches

Run # 3

Test Run Fuel Moisture (db)	Hydronic Heater						AVG (%)	Weight Without Cleats (Lbs)	
	S1	S2	S3	S4	S5	S6		Fuel	
Piece 1	20.5	21.4	21.1				21.0		1.79
Piece 2	23.2	22.1	22.8				22.7		1.57
Piece 3	20.3	21.5	21.9				21.2		1.87
Piece 4	23.3	22.6	21.7				22.5		1.94
Piece 5									
Piece 6									
Piece 7									
Piece 8									
Piece 9									
Piece 10									
Piece 11									
Piece 12									
Piece 13									
Piece 14									
Piece 15									
Spacer Average	19							21.3	W/Cleats 9.04

Signature

Date

Fuel Load Information

Project Number  
037-S-048-6B

Client  
New Buck Corporation





Date  
8/12/2016

Firebox Volume (ft<sup>3</sup>) 1.4

Assessment No

Longest useable measurement parallel or perpendicular to front of unit. 18.5"

Test Fuel Charge Range 8.8 - 10.8  
Coal bed range (lbs) 1.90 - 2.50

Vol ≤ 1.5 ft <sup>3</sup>	Vol > 1.5 ≤ 3.0 ft <sup>3</sup>	Vol > 3.0 ft <sup>3</sup>
		
		

Fuel Piece Length 16.00 Inches

Run # 4

Test Run Fuel Moisture (db)	Hydronic Heater						AVG (%)	Weight Without Cleats (Lbs)	
	S1	S2	S3	S4	S5	S6		Fuel	
Piece 1	22.2	22.4	23.1				22.6		1.98
Piece 2	20.3	21.2	21.4				21.0		1.92
Piece 3	19.3	19.3	19.9				19.5		1.70
Piece 4	19.3	19.7	19.0				19.3		1.65
Piece 5									
Piece 6									
Piece 7									
Piece 8									
Piece 9									
Piece 10									
Piece 11									
Piece 12									
Piece 13									
Piece 14									
Piece 15									
Spacer Average	19.8							20.4	W/Cleats 8.90

Signature

Date

Fuel Load Information

Project Number  
037-S-048-6B

Client  
New Buck Corporation





Date  
8/16/2016

Firebox Volume (ft<sup>3</sup>) 1.4

Assessment No

Longest useable measurement parallel or perpendicular to front of unit. 18.5"

Test Fuel Charge Range 8.8 - 10.8  
Coal bed range (lbs) 1.90 - 2.50

Vol ≤ 1.5 ft <sup>3</sup>	Vol > 1.5 ≤ 3.0 ft <sup>3</sup>	Vol > 3.0 ft <sup>3</sup>
		
		

Fuel Piece Length 16.00 Inches

Run # 5

Test Run Fuel Moisture (db)	Hydronic Heater						AVG (%)	Weight Without Cleats (Lbs)	
	S1	S2	S3	S4	S5	S6		Fuel	
Piece 1	19.0	19.0	19.0				19.0		1.96
Piece 2	19.0	19.0	19.1				19.0		1.85
Piece 3	19.2	19.3	19.3				19.3		1.79
Piece 4	19.4	19.9	19.8				19.7		1.92
Piece 5									
Piece 6									
Piece 7									
Piece 8									
Piece 9									
Piece 10									
Piece 11									
Piece 12									
Piece 13									
Piece 14									
Piece 15									
Spacer Average	19							19.2	W/Cleats 9.20

Signature

Date





Small white tag with illegible text.

Buck & Stone

MADE IN

**ATTENTION:**

THIS SEAL IS NOT TO BE BROKEN WITHOUT PRIOR APPROVAL  
FROM THE UNITED STATES ENVIRONMENTAL PROTECTION AGENCY

THIS APPLIANCE HAS BEEN SEALED IN ACCORDANCE WITH  
REQUIREMENTS OF 40 CFR PART 60 SUBPART A AND SUBPART G

DATE SEALED

REPORT # 037-S-048-6B

MANUFACTURER New Buck Corporation MODEL # 210





TrueAStove







005

003

0000



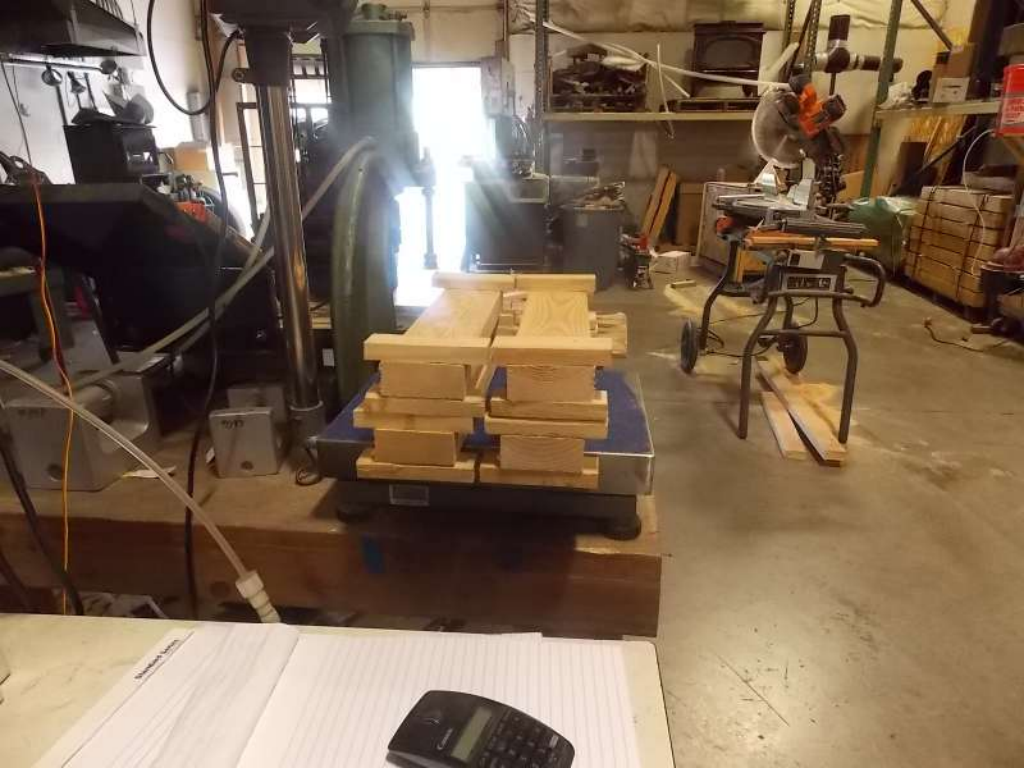















[report this ad](#)

# Troutdale, OR

Portland-Troutdale

© 5:16 PM PDT on September 01, 2016 [GMT -0700]

## Weather History for KTTD - August, 2016

August

9

2016

### View

Tuesday, August 9, 2016

Daily	Weekly	Monthly	Custom		Actual	Average	Record
Temperature							
Mean Temperature					64 °F	69 °F	
Max Temperature					70 °F	83 °F	106 °F [1981]
Min Temperature					58 °F	55 °F	45 °F [1954]
Degree Days							
Heating Degree Days					1	1	
Month to date heating degree days					2	9	
Cooling Degree Days					0	5	
Month to date cooling degree days					27	45	
Growing Degree Days					14 [Base 50]		
Moisture							
Dew Point					56 °F		
Average Humidity					77		
Maximum Humidity					90		
Minimum Humidity					63		
Precipitation							
Precipitation					0.01 in	0.02 in	1.02 in [1992]

	Actual	Average	Record
Month to date precipitation	0.07	0.15	
Year to date precipitation	20.30	26.01	
Sea Level Pressure			
Sea Level Pressure	30.03 in		
Wind			
Wind Speed	3 mph (WSW)		
Max Wind Speed	9 mph		
Max Gust Speed	14 mph		
Visibility	9 miles		
Events	Rain		

T = Trace of Precipitation, MM = Missing Value

Source: NWS Daily Summary

### Daily Weather History Graph

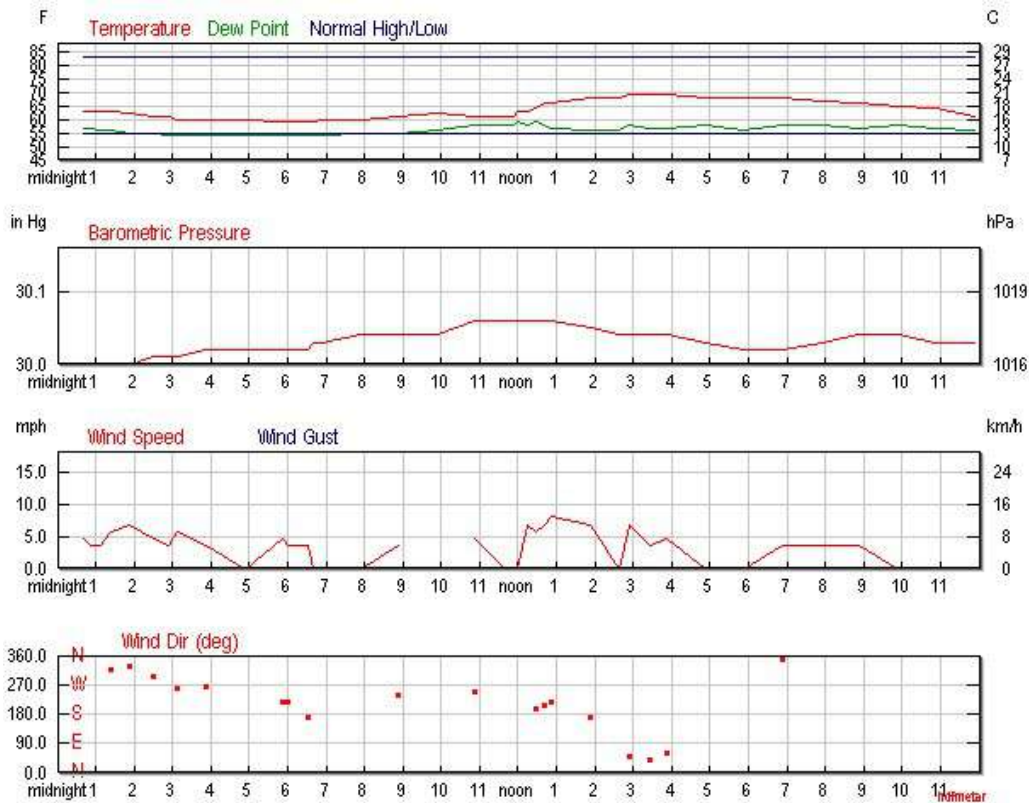

report this ad | why ads?

### Search for Another Location

Airport or City:

KTTD

[Submit](#)

## Trip Planner

Search our weather history database for the weather conditions in past years. The results will help you decide how hot, cold, wet, or windy it might be!

Date:

August

9

[Submit](#)[report this ad](#) | [why ads?](#)

## Astronomy

Aug. 09, 2016	Rise	Set
Actual Time	6:03 AM PDT	8:25 PM PDT
<a href="#">Civil Twilight</a>	5:30 AM PDT	8:58 PM PDT
<a href="#">Nautical Twilight</a>	4:49 AM PDT	9:39 PM PDT
<a href="#">Astronomical Twilight</a>	4:02 AM PDT	10:25 PM PDT
Moon	1:02 PM PDT (8/9)	11:52 PM PDT (8/9)
<a href="#">Length of Visible Light</a>	15h 27m	
<a href="#">Length of Day</a>	14h 21m	

**Waxing Crescent, 41%** of the Moon is Illuminated

Aug 9	Aug 10	Aug 18	Aug 24	Sep 1
Waxing Crescent	First Quarter	Full	Last Quarter	New

[report this ad](#) | [why ads?](#)

## Hourly Weather History & Observations

Time (PDT)	Temp.	Dew Point	Humidity	Pressure	Visibility	Wind Dir	Wind Speed	Gust Speed	Precip	Events	Conditions
12:42 AM	63.0 °F	57.0 °F	81%	30.00 in	10.0 mi	Variable	4.6 mph	-	N/A		Overcast
12:53 AM	63.0 °F	57.0 °F	81%	30.00 in	10.0 mi	Variable	3.5 mph	-	N/A		Overcast

Time (PDT)	Temp.	Dew Point	Humidity	Pressure	Visibility	Wind Dir	Wind Speed	Gust Speed	Precip	Events	Conditions
1:08 AM	63.0 °F	55.9 °F	78%	30.00 in	10.0 mi	Variable	3.5 mph	-	N/A		Mostly Cloudy
1:24 AM	63.0 °F	55.9 °F	78%	30.00 in	10.0 mi	NW	5.8 mph	-	N/A		Mostly Cloudy
1:53 AM	62.1 °F	55.0 °F	78%	30.00 in	10.0 mi	NNW	6.9 mph	-	N/A		Overcast
2:30 AM	61.0 °F	55.0 °F	81%	30.01 in	10.0 mi	WNW	4.6 mph	-	N/A		Overcast
2:53 AM	61.0 °F	54.0 °F	78%	30.01 in	10.0 mi	Variable	3.5 mph	-	N/A		Mostly Cloudy
3:08 AM	60.1 °F	54.0 °F	80%	30.01 in	10.0 mi	West	5.8 mph	-	N/A		Partly Cloudy
3:53 AM	60.1 °F	54.0 °F	80%	30.02 in	10.0 mi	West	3.5 mph	-	N/A		Mostly Cloudy
4:53 AM	60.1 °F	54.0 °F	80%	30.02 in	10.0 mi	Calm	Calm	-	N/A		Overcast
5:53 AM	59.0 °F	54.0 °F	83%	30.02 in	10.0 mi	SW	4.6 mph	-	N/A		Mostly Cloudy
6:01 AM	59.0 °F	54.0 °F	83%	30.02 in	10.0 mi	SW	3.5 mph	-	N/A		Overcast
6:32 AM	59.0 °F	54.0 °F	83%	30.02 in	10.0 mi	South	3.5 mph	-	N/A		Overcast
6:39 AM	59.0 °F	54.0 °F	83%	30.03 in	10.0 mi	Calm	Calm	-	N/A		Overcast
6:53 AM	60.1 °F	54.0 °F	80%	30.03 in	10.0 mi	Calm	Calm	-	N/A		Overcast
7:53 AM	60.1 °F	55.0 °F	83%	30.04 in	5.0 mi	Calm	Calm	-	N/A		Haze
8:53 AM	61.0 °F	55.0 °F	81%	30.04 in	8.0 mi	WSW	3.5 mph	-	0.00 in	Rain	Light Rain
9:53 AM	62.1 °F	55.9 °F	80%	30.04 in	10.0 mi	North	-	-	0.00 in		Overcast
10:53 AM	61.0 °F	57.9 °F	90%	30.06 in	3.0 mi	WSW	4.6 mph	-	0.00 in		Overcast
11:40 AM	61.0 °F	57.9 °F	90%	30.06 in	3.0 mi	Calm	Calm	-	0.01 in		Overcast
11:53 AM	61.0 °F	57.9 °F	90%	30.06 in	4.0 mi	Calm	Calm	-	0.01 in	Rain	Light Rain
11:59 AM	63.0 °F	59.0 °F	87%	30.06 in	10.0 mi	Calm	Calm	-	0.00 in		Overcast
12:14 PM	63.0 °F	57.9 °F	84%	30.06 in	10.0 mi	Variable	6.9 mph	-	0.00 in		Overcast

Time (PDT)	Temp.	Dew Point	Humidity	Pressure	Visibility	Wind Dir	Wind Speed	Gust Speed	Precip	Events	Conditions
12:28 PM	64.0 °F	59.0 °F	84%	30.06 in	10.0 mi	SSW	5.8 mph	-	0.00 in		Overcast
12:41 PM	66.0 °F	57.9 °F	75%	30.06 in	10.0 mi	SSW	6.9 mph	-	0.00 in		Overcast
12:53 PM	66.0 °F	57.0 °F	73%	30.06 in	10.0 mi	SW	8.1 mph	-	0.00 in		Overcast
1:53 PM	68.0 °F	55.9 °F	65%	30.05 in	10.0 mi	South	6.9 mph	-	N/A		Overcast
2:37 PM	68.0 °F	55.9 °F	65%	30.04 in	10.0 mi	Calm	Calm	-	N/A		Overcast
2:53 PM	69.1 °F	57.9 °F	68%	30.04 in	10.0 mi	NE	6.9 mph	-	N/A		Overcast
3:27 PM	69.1 °F	57.0 °F	65%	30.04 in	10.0 mi	NE	3.5 mph	-	N/A		Overcast
3:53 PM	69.1 °F	57.0 °F	65%	30.04 in	10.0 mi	ENE	4.6 mph	-	N/A		Overcast
4:53 PM	68.0 °F	57.9 °F	70%	30.03 in	10.0 mi	Calm	Calm	-	N/A		Overcast
5:53 PM	68.0 °F	55.9 °F	65%	30.02 in	10.0 mi	Calm	Calm	-	N/A		Overcast
6:53 PM	68.0 °F	57.9 °F	70%	30.02 in	10.0 mi	North	3.5 mph	-	N/A		Overcast
7:53 PM	66.9 °F	57.9 °F	73%	30.03 in	10.0 mi	Variable	3.5 mph	-	N/A		Overcast
8:53 PM	66.0 °F	57.0 °F	73%	30.04 in	10.0 mi	Variable	3.5 mph	-	N/A		Overcast
9:53 PM	64.9 °F	57.9 °F	78%	30.04 in	10.0 mi	Calm	Calm	-	N/A		Overcast
10:53 PM	64.0 °F	57.0 °F	78%	30.03 in	10.0 mi	Calm	Calm	-	N/A		Overcast
11:53 PM	61.0 °F	55.9 °F	83%	30.03 in	10.0 mi	Calm	Calm	-	N/A		Clear

||

report this ad



[report this ad](#)

# Troutdale, OR

Portland-Troutdale

© 5:17 PM PDT on September 01, 2016 [GMT -0700]

## Weather History for KTTD - August, 2016

August

10

2016

**View**

Wednesday, August 10, 2016

<b>Daily</b>	Weekly	Monthly	Custom
--------------	--------	---------	--------

	Actual	Average	Record
<b>Temperature</b>			
Mean Temperature	70 °F	69 °F	
Max Temperature	81 °F	83 °F	105 °F [1981]
Min Temperature	59 °F	55 °F	47 °F [1964]
<b>Degree Days</b>			
Heating Degree Days	0	1	
Month to date heating degree days	2	10	
Cooling Degree Days	5	4	
Month to date cooling degree days	32	49	
Growing Degree Days	20 [Base 50]		
<b>Moisture</b>			
Dew Point	57 °F		
Average Humidity	68		
Maximum Humidity	93		
Minimum Humidity	42		
<b>Precipitation</b>			
Precipitation	0.00 in	0.02 in	0.30 in [1965]
Month to date precipitation	0.07	0.17	
Year to date precipitation	20.30	26.03	

	Actual	Average	Record
Sea Level Pressure			
Sea Level Pressure	30.04 in		
Wind			
Wind Speed	3 mph (West)		
Max Wind Speed	8 mph		
Max Gust Speed	14 mph		
Visibility	10 miles		
Events			

T = Trace of Precipitation, MM = Missing Value

Source: NWS Daily Summary

Daily Weather History Graph

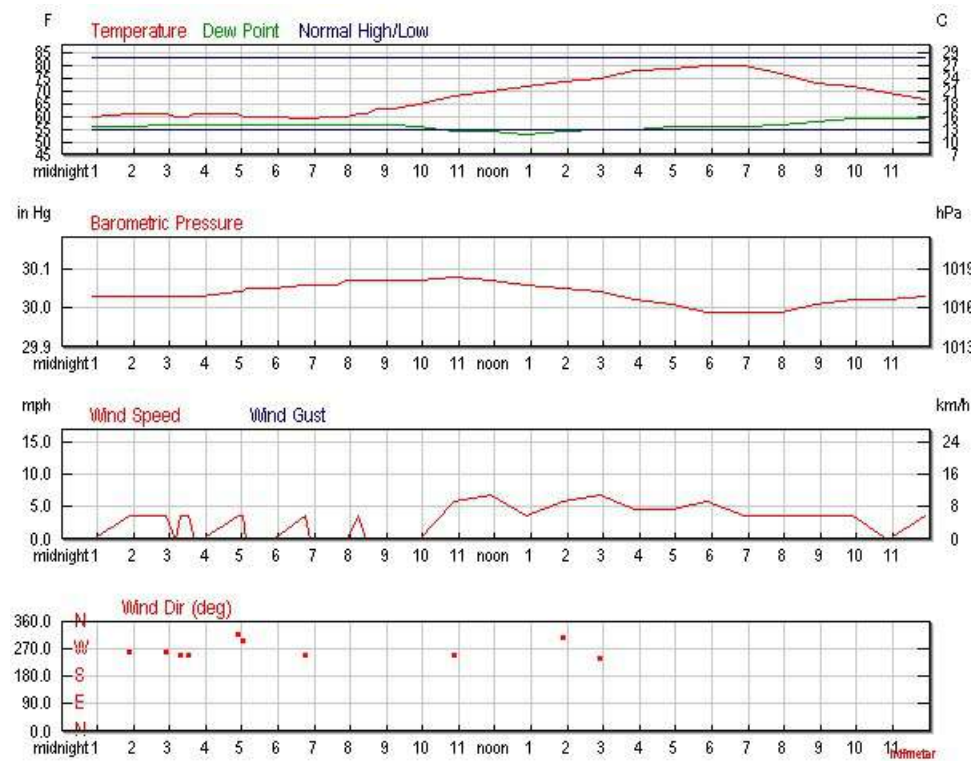

report this ad | why ads?

Search for Another Location

Airport or City:

KTTD

Submit

Trip Planner

Search our weather history database for the weather conditions in past years. The results will help you decide how hot, cold, wet, or windy it might be!

Date:

August

10

**Submit**

[report this ad](#) | [why ads?](#)

### Astronomy

Aug. 10, 2016	Rise	Set
Actual Time	6:04 AM PDT	8:24 PM PDT
<a href="#">Civil Twilight</a>	5:31 AM PDT	8:56 PM PDT
<a href="#">Nautical Twilight</a>	4:50 AM PDT	9:37 PM PDT
<a href="#">Astronomical Twilight</a>	4:04 AM PDT	10:23 PM PDT
Moon	2:00 PM PDT (8/10)	No Moon Set
<a href="#">Length of Visible Light</a>	15h 24m	
<a href="#">Length of Day</a>	14h 19m	

**Waxing Crescent, 50%** of the Moon is Illuminated

Aug 10	Aug 18	Aug 24	Sep 1	Sep 9
Waxing Crescent	Full	Last Quarter	New	First Quarter

[report this ad](#) | [why ads?](#)

### Hourly Weather History & Observations

Time (PDT)	Temp.	Heat Index	Dew Point	Humidity	Pressure	Visibility	Wind Dir	Wind Speed	Gust Speed	Precip	Events	Conditions
12:53 AM	60.1 °F	-	55.9 °F	86%	30.03 in	10.0 mi	Calm	Calm	-	N/A		Mostly Cloudy
1:53 AM	61.0 °F	-	55.9 °F	83%	30.03 in	10.0 mi	West	3.5 mph	-	N/A		Overcast
2:53 AM	61.0 °F	-	57.0 °F	87%	30.03 in	10.0 mi	West	3.5 mph	-	N/A		Overcast
3:09 AM	60.1 °F	-	57.0 °F	90%	30.03 in	10.0 mi	Calm	Calm	-	N/A		Overcast
3:18 AM	60.1 °F	-	57.0 °F	90%	30.03 in	10.0 mi	WSW	3.5 mph	-	N/A		Overcast
3:30 AM	60.1 °F	-	57.0 °F	90%	30.03 in	10.0 mi	WSW	3.5 mph	-	N/A		Overcast
3:41 AM	61.0 °F	-	57.0 °F	87%	30.03 in	10.0 mi	Calm	Calm	-	N/A		Overcast

Time (PDT)	Temp.	Heat Index	Dew Point	Humidity	Pressure	Visibility	Wind Dir	Wind Speed	Gust Speed	Precip	Events	Conditions
3:53 AM	61.0 °F	-	57.0 °F	87%	30.03 in	10.0 mi	Calm	Calm	-	N/A		Overcast
4:53 AM	61.0 °F	-	57.0 °F	87%	30.04 in	10.0 mi	NW	3.5 mph	-	N/A		Overcast
5:01 AM	60.1 °F	-	57.0 °F	90%	30.04 in	10.0 mi	WNW	3.5 mph	-	N/A		Overcast
5:08 AM	60.1 °F	-	57.0 °F	90%	30.05 in	10.0 mi	Calm	Calm	-	N/A		Overcast
5:32 AM	60.1 °F	-	57.0 °F	90%	30.05 in	10.0 mi	Calm	Calm	-	N/A		Overcast
5:53 AM	60.1 °F	-	57.0 °F	90%	30.05 in	10.0 mi	Calm	Calm	-	N/A		Overcast
6:45 AM	59.0 °F	-	57.0 °F	93%	30.06 in	10.0 mi	WSW	3.5 mph	-	N/A		Overcast
6:53 AM	59.0 °F	-	57.0 °F	93%	30.06 in	10.0 mi	Calm	Calm	-	N/A		Overcast
7:22 AM	60.1 °F	-	57.0 °F	90%	30.06 in	10.0 mi	Calm	Calm	-	N/A		Mostly Cloudy
7:35 AM	60.1 °F	-	57.0 °F	90%	30.06 in	10.0 mi	Calm	Calm	-	N/A		Mostly Cloudy
7:53 AM	60.1 °F	-	57.0 °F	90%	30.07 in	10.0 mi	Calm	Calm	-	N/A		Overcast
8:13 AM	61.0 °F	-	57.0 °F	87%	30.07 in	10.0 mi	Variable	3.5 mph	-	N/A		Overcast
8:27 AM	61.0 °F	-	57.0 °F	87%	30.07 in	10.0 mi	Calm	Calm	-	N/A		Overcast
8:44 AM	63.0 °F	-	57.0 °F	81%	30.07 in	10.0 mi	Calm	Calm	-	N/A		Overcast
8:53 AM	63.0 °F	-	57.0 °F	81%	30.07 in	10.0 mi	Calm	Calm	-	N/A		Overcast
9:11 AM	63.0 °F	-	57.0 °F	81%	30.07 in	10.0 mi	Calm	Calm	-	N/A		Overcast
9:53 AM	64.9 °F	-	55.9 °F	73%	30.07 in	10.0 mi	Calm	Calm	-	N/A		Partly Cloudy
10:53 AM	68.0 °F	-	54.0 °F	61%	30.08 in	10.0 mi	WSW	5.8 mph	-	N/A		Mostly Cloudy
11:53 AM	70.0 °F	-	54.0 °F	57%	30.07 in	10.0 mi	Variable	6.9 mph	-	N/A		Partly Cloudy
12:53 PM	72.0 °F	-	53.1 °F	51%	30.06 in	10.0 mi	Variable	3.5 mph	-	N/A		Partly Cloudy
1:53 PM	73.9 °F	-	54.0 °F	50%	30.05 in	10.0 mi	NW	5.8 mph	-	N/A		Clear
2:53 PM	75.0 °F	-	55.0 °F	50%	30.04 in	10.0 mi	WSW	6.9 mph	-	N/A		Clear

Time (PDT)	Temp.	Heat Index	Dew Point	Humidity	Pressure	Visibility	Wind Dir	Wind Speed	Gust Speed	Precip	Events	Conditions
3:53 PM	78.1 °F	-	55.0 °F	45%	30.02 in	10.0 mi	Variable	4.6 mph	-	N/A		Clear
4:53 PM	79.0 °F	-	55.9 °F	45%	30.01 in	10.0 mi	Variable	4.6 mph	-	N/A		Clear
5:53 PM	80.1 °F	80.2 °F	55.9 °F	43%	29.99 in	10.0 mi	Variable	5.8 mph	-	N/A		Clear
6:53 PM	80.1 °F	80.2 °F	55.9 °F	43%	29.99 in	10.0 mi	Variable	3.5 mph	-	N/A		Clear
7:53 PM	77.0 °F	-	57.0 °F	50%	29.99 in	10.0 mi	Variable	3.5 mph	-	N/A		Clear
8:53 PM	73.0 °F	-	57.9 °F	59%	30.01 in	10.0 mi	Variable	3.5 mph	-	N/A		Clear
9:53 PM	72.0 °F	-	59.0 °F	64%	30.02 in	10.0 mi	Variable	3.5 mph	-	N/A		Clear
10:53 PM	69.1 °F	-	59.0 °F	70%	30.02 in	10.0 mi	Calm	Calm	-	N/A		Clear
11:53 PM	66.9 °F	-	59.0 °F	76%	30.03 in	10.0 mi	Variable	3.5 mph	-	N/A		Clear

||

[report this ad](#)

[report this ad](#)

# Troutdale, OR

Portland-Troutdale

© 5:17 PM PDT on September 01, 2016 (GMT -0700)

## Weather History for KTTD - August, 2016

August

11

2016

### View

Thursday, August 11, 2016

<b>Daily</b>	Weekly	Monthly	Custom
--------------	--------	---------	--------

	Actual	Average	Record
<b>Temperature</b>			
Mean Temperature	73 °F	69 °F	
Max Temperature	90 °F	83 °F	104 °F [1977]
Min Temperature	56 °F	55 °F	45 °F [1998]
<b>Degree Days</b>			
Heating Degree Days	0	1	
Month to date heating degree days	2	11	
Cooling Degree Days	8	4	
Month to date cooling degree days	40	53	
Growing Degree Days	24 [Base 50]		
<b>Moisture</b>			
Dew Point	58 °F		
Average Humidity	64		
Maximum Humidity	93		
Minimum Humidity	34		
<b>Precipitation</b>			
Precipitation	0.00 in	0.02 in	0.38 in [1995]
Month to date precipitation	0.07	0.19	
Year to date precipitation	20.30	26.05	
<b>Sea Level Pressure</b>			

	Actual	Average	Record
Sea Level Pressure	30.04 in		
Wind			
Wind Speed	3 mph (WSW)		
Max Wind Speed	10 mph		
Max Gust Speed	16 mph		
Visibility	10 miles		
Events			

T = Trace of Precipitation, MM = Missing Value

Source: NWS Daily Summary

Daily Weather History Graph

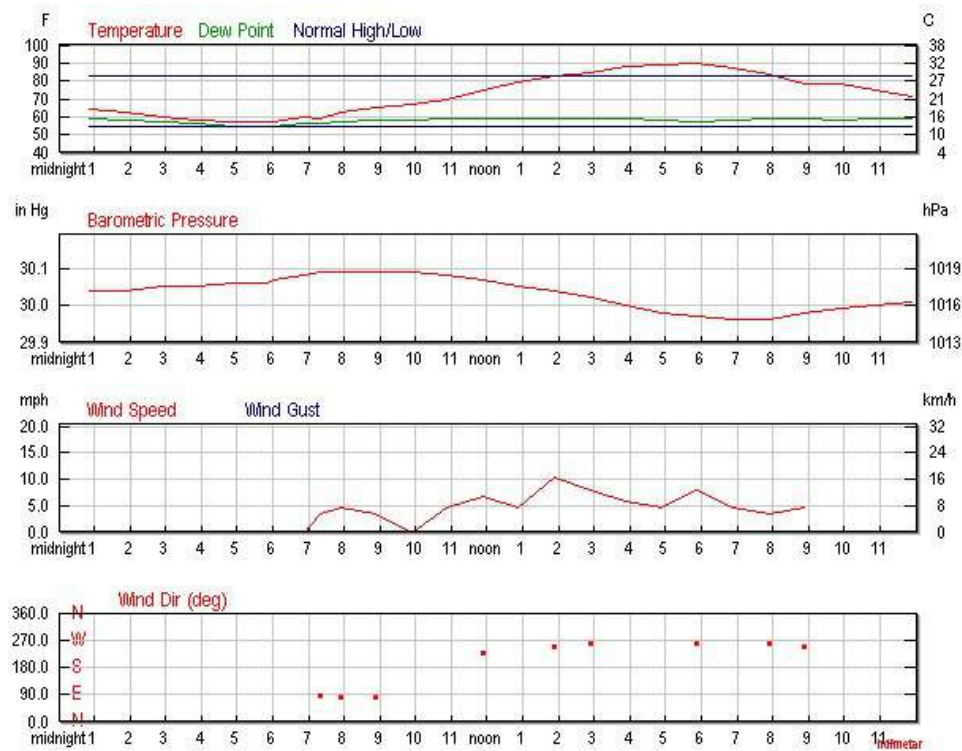

report this ad | why ads?

Search for Another Location

Airport or City:

KTTD

Submit

Trip Planner

Search our weather history database for the weather conditions in past years. The results will help you decide how hot, cold, wet, or windy it might be!

Date:

August

11

**Submit**

[report this ad](#) | [why ads?](#)

### Astronomy

Aug. 11, 2016	Rise	Set
Actual Time	6:06 AM PDT	8:22 PM PDT
<a href="#">Civil Twilight</a>	5:33 AM PDT	8:55 PM PDT
<a href="#">Nautical Twilight</a>	4:52 AM PDT	9:35 PM PDT
<a href="#">Astronomical Twilight</a>	4:06 AM PDT	10:20 PM PDT
Moon	2:57 PM PDT [8/11]	12:24 AM PDT [8/11]
<a href="#">Length of Visible Light</a>	15h 21m	
<a href="#">Length of Day</a>	14h 16m	

**First Quarter, 60% of the Moon is Illuminated**

Aug 11	Aug 18	Aug 24	Sep 1	Sep 9
First Quarter	Full	Last Quarter	New	First Quarter

[report this ad](#) | [why ads?](#)

### Hourly Weather History & Observations

Time (PDT)	Temp.	Heat Index	Dew Point	Humidity	Pressure	Visibility	Wind Dir	Wind Speed	Gust Speed	Precip	Events	Conditions
12:53 AM	64.0 °F	-	59.0 °F	84%	30.04 in	10.0 mi	Calm	Calm	-	N/A		Clear
1:53 AM	62.1 °F	-	57.9 °F	86%	30.04 in	10.0 mi	Calm	Calm	-	N/A		Clear
2:53 AM	60.1 °F	-	57.0 °F	90%	30.05 in	10.0 mi	Calm	Calm	-	N/A		Clear
3:53 AM	57.9 °F	-	55.9 °F	93%	30.05 in	10.0 mi	Calm	Calm	-	N/A		Clear
4:53 AM	57.0 °F	-	55.0 °F	93%	30.06 in	10.0 mi	Calm	Calm	-	N/A		Clear
5:53 AM	57.0 °F	-	55.0 °F	93%	30.06 in	10.0 mi	Calm	Calm	-	N/A		Scattered Clouds
6:00 AM	57.0 °F	-	55.0 °F	93%	30.07 in	10.0 mi	Calm	Calm	-	N/A		Mostly Cloudy



Time (PDT)	Temp.	Heat Index	Dew Point	Humidity	Pressure	Visibility	Wind Dir	Wind Speed	Gust Speed	Precip	Events	Conditions
6:53 AM	60.1 °F	-	55.9 °F	86%	30.08 in	10.0 mi	Calm	Calm	-	N/A		Overcast
7:20 AM	59.0 °F	-	55.9 °F	90%	30.09 in	10.0 mi	East	3.5 mph	-	N/A		Scattered Clouds
7:53 AM	62.1 °F	-	57.0 °F	84%	30.09 in	10.0 mi	East	4.6 mph	-	N/A		Scattered Clouds
8:53 AM	64.9 °F	-	57.9 °F	78%	30.09 in	10.0 mi	East	3.5 mph	-	N/A		Scattered Clouds
9:53 AM	66.9 °F	-	57.9 °F	73%	30.09 in	10.0 mi	Calm	Calm	-	N/A		Scattered Clouds
10:53 AM	70.0 °F	-	59.0 °F	68%	30.08 in	10.0 mi	Variable	4.6 mph	-	N/A		Clear
11:53 AM	75.0 °F	-	59.0 °F	57%	30.07 in	10.0 mi	SW	6.9 mph	-	N/A		Clear
12:53 PM	79.0 °F	-	59.0 °F	50%	30.05 in	10.0 mi	Variable	4.6 mph	-	N/A		Clear
1:53 PM	82.9 °F	82.8 °F	59.0 °F	44%	30.04 in	10.0 mi	WSW	10.4 mph	-	N/A		Clear
2:53 PM	84.9 °F	84.4 °F	59.0 °F	41%	30.02 in	10.0 mi	West	8.1 mph	-	N/A		Clear
3:53 PM	88.0 °F	87.1 °F	59.0 °F	37%	30.00 in	10.0 mi	Variable	5.8 mph	-	N/A		Clear
4:53 PM	89.1 °F	88.0 °F	57.9 °F	35%	29.98 in	10.0 mi	Variable	4.6 mph	-	N/A		Clear
5:53 PM	90.0 °F	88.6 °F	57.0 °F	33%	29.97 in	10.0 mi	West	8.1 mph	-	N/A		Clear
6:53 PM	87.1 °F	86.1 °F	57.9 °F	37%	29.96 in	10.0 mi	Variable	4.6 mph	-	N/A		Clear
7:53 PM	84.0 °F	83.8 °F	59.0 °F	43%	29.96 in	10.0 mi	West	3.5 mph	-	N/A		Clear
8:53 PM	78.1 °F	-	59.0 °F	52%	29.98 in	10.0 mi	WSW	4.6 mph	-	N/A		Clear
9:53 PM	78.1 °F	-	57.9 °F	50%	29.99 in	10.0 mi	North	-	-	N/A		Clear
10:53 PM	75.0 °F	-	59.0 °F	57%	30.00 in	10.0 mi	Calm	Calm	-	N/A		Clear
11:53 PM	71.1 °F	-	59.0 °F	66%	30.01 in	10.0 mi	Calm	Calm	-	N/A		Clear

||

report this ad

[report this ad](#)

# Troutdale, OR

Portland-Troutdale

© 5:18 PM PDT on September 01, 2016 [GMT -0700]

## Weather History for KTTD - August, 2016

August

12

2016

**View**

Friday, August 12, 2016

<b>Daily</b>	Weekly	Monthly	Custom
--------------	--------	---------	--------

	Actual	Average	Record
<b>Temperature</b>			
Mean Temperature	80 °F	69 °F	
Max Temperature	98 °F	83 °F	105 °F [1977]
Min Temperature	61 °F	54 °F	47 °F [1966]
<b>Degree Days</b>			
Heating Degree Days	0	1	
Month to date heating degree days	2	12	
Cooling Degree Days	15	4	
Month to date cooling degree days	55	57	
Growing Degree Days	29 [Base 50]		
<b>Moisture</b>			
Dew Point	59 °F		
Average Humidity	60		
Maximum Humidity	97		
Minimum Humidity	22		
<b>Precipitation</b>			
Precipitation	0.00 in	0.02 in	0.25 in [1965]
Month to date precipitation	0.07	0.21	
Year to date precipitation	20.30	26.07	

	Actual	Average	Record
Sea Level Pressure			
Sea Level Pressure	29.99 in		
Wind			
Wind Speed	4 mph [WSW]		
Max Wind Speed	10 mph		
Max Gust Speed	15 mph		
Visibility	10 miles		
Events			

T = Trace of Precipitation, MM = Missing Value

Source: NWS Daily Summary

### Daily Weather History Graph

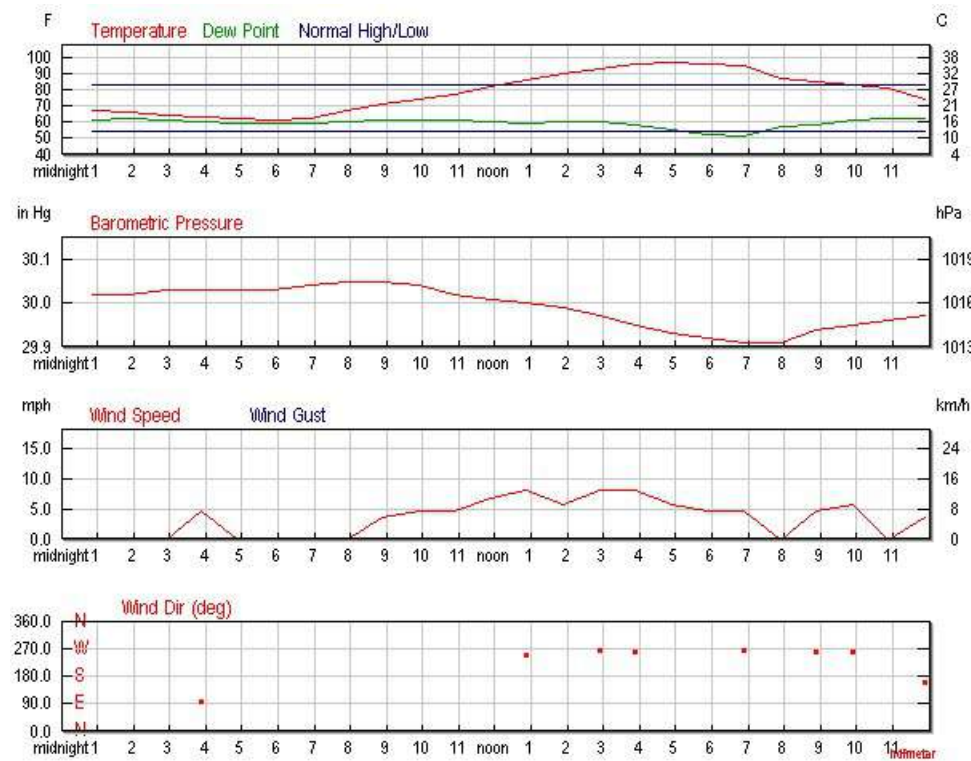

report this ad | why ads?

### Search for Another Location

Airport or City:

KTTD

Submit

### Trip Planner

Search our weather history database for the weather conditions in past years. The results will help you decide how hot, cold, wet, or windy it might be!

Date:

August

12

**Submit**

[report this ad](#) | [why ads?](#)

### Astronomy

Aug. 12, 2016	Rise	Set
Actual Time	6:07 AM PDT	8:20 PM PDT
<a href="#">Civil Twilight</a>	5:34 AM PDT	8:53 PM PDT
<a href="#">Nautical Twilight</a>	4:54 AM PDT	9:33 PM PDT
<a href="#">Astronomical Twilight</a>	4:08 AM PDT	10:18 PM PDT
Moon	3:54 PM PDT [8/12]	1:00 AM PDT [8/12]
<a href="#">Length of Visible Light</a>	15h 18m	
<a href="#">Length of Day</a>	14h 13m	

**Waxing Gibbous, 69%** of the Moon is Illuminated

Aug 12	Aug 18	Aug 24	Sep 1	Sep 9
Waxing Gibbous	Full	Last Quarter	New	First Quarter

[report this ad](#) | [why ads?](#)

### Hourly Weather History & Observations

Time (PDT)	Temp.	Heat Index	Dew Point	Humidity	Pressure	Visibility	Wind Dir	Wind Speed	Gust Speed	Precip	Events	Conditions
12:53 AM	66.9 °F	-	61.0 °F	81%	30.02 in	10.0 mi	Calm	Calm	-	N/A		Clear
1:53 AM	66.0 °F	-	62.1 °F	87%	30.02 in	10.0 mi	Calm	Calm	-	N/A		Clear
2:53 AM	64.0 °F	-	61.0 °F	90%	30.03 in	10.0 mi	Calm	Calm	-	N/A		Clear
3:53 AM	63.0 °F	-	60.1 °F	90%	30.03 in	10.0 mi	East	4.6 mph	-	N/A		Clear
4:53 AM	62.1 °F	-	59.0 °F	90%	30.03 in	10.0 mi	Calm	Calm	-	N/A		Clear
5:53 AM	61.0 °F	-	59.0 °F	93%	30.03 in	10.0 mi	Calm	Calm	-	N/A		Clear
6:53 AM	62.1 °F	-	59.0 °F	90%	30.04 in	10.0 mi	Calm	Calm	-	N/A		Clear

Time (PDT)	Temp.	Heat Index	Dew Point	Humidity	Pressure	Visibility	Wind Dir	Wind Speed	Gust Speed	Precip	Events	Conditions
7:53 AM	66.9 °F	-	60.1 °F	79%	30.05 in	10.0 mi	Calm	Calm	-	N/A		Clear
8:53 AM	71.1 °F	-	61.0 °F	70%	30.05 in	10.0 mi	Variable	3.5 mph	-	N/A		Clear
9:53 AM	73.9 °F	-	61.0 °F	64%	30.04 in	10.0 mi	Variable	4.6 mph	-	N/A		Clear
10:53 AM	77.0 °F	-	61.0 °F	58%	30.02 in	10.0 mi	Variable	4.6 mph	-	N/A		Clear
11:53 AM	82.0 °F	82.4 °F	60.1 °F	47%	30.01 in	10.0 mi	Variable	6.9 mph	-	N/A		Clear
12:53 PM	86.0 °F	85.4 °F	59.0 °F	40%	30.00 in	10.0 mi	WSW	8.1 mph	-	N/A		Clear
1:53 PM	90.0 °F	89.7 °F	60.1 °F	37%	29.99 in	10.0 mi	Variable	5.8 mph	-	N/A		Clear
2:53 PM	93.0 °F	92.7 °F	60.1 °F	33%	29.97 in	10.0 mi	West	8.1 mph	-	N/A		Clear
3:53 PM	96.1 °F	95.2 °F	57.9 °F	28%	29.95 in	10.0 mi	West	8.1 mph	-	N/A		Clear
4:53 PM	97.0 °F	95.0 °F	55.0 °F	24%	29.93 in	10.0 mi	Variable	5.8 mph	-	N/A		Clear
5:53 PM	96.1 °F	-	52.0 °F	22%	29.92 in	10.0 mi	Variable	4.6 mph	-	N/A		Clear
6:53 PM	95.0 °F	-	51.1 °F	22%	29.91 in	10.0 mi	West	4.6 mph	-	N/A		Clear
7:53 PM	87.1 °F	85.9 °F	57.0 °F	36%	29.91 in	10.0 mi	Calm	Calm	-	N/A		Clear
8:53 PM	84.9 °F	84.2 °F	57.9 °F	40%	29.94 in	10.0 mi	West	4.6 mph	-	N/A		Clear
9:53 PM	82.9 °F	83.3 °F	61.0 °F	47%	29.95 in	10.0 mi	West	5.8 mph	-	N/A		Clear
10:53 PM	81.0 °F	81.9 °F	62.1 °F	52%	29.96 in	10.0 mi	Calm	Calm	-	N/A		Clear
11:53 PM	73.9 °F	-	62.1 °F	66%	29.97 in	10.0 mi	SSE	3.5 mph	-	N/A		Clear

||

report this ad

[report this ad](#)

# Troutdale, OR

Portland-Troutdale

© 5:19 PM PDT on September 01, 2016 (GMT -0700)

## Weather History for KTTD - August, 2016

August

16

2016

**View**

Tuesday, August 16, 2016

<b>Daily</b>	Weekly	Monthly	Custom
--------------	--------	---------	--------

	Actual	Average	Record
<b>Temperature</b>			
Mean Temperature	73 °F	68 °F	
Max Temperature	86 °F	82 °F	103 °F [1977]
Min Temperature	59 °F	54 °F	47 °F [1969]
<b>Degree Days</b>			
Heating Degree Days	0	1	
Month to date heating degree days	2	16	
Cooling Degree Days	8	4	
Month to date cooling degree days	94	73	
Growing Degree Days	22 [Base 50]		
<b>Moisture</b>			
Dew Point	56 °F		
Average Humidity	62		
Maximum Humidity	84		
Minimum Humidity	40		
<b>Precipitation</b>			
Precipitation	0.00 in	0.03 in	0.55 in [1976]
Month to date precipitation	0.07	0.30	
Year to date precipitation	20.30	26.16	
<b>Sea Level Pressure</b>			

	Actual	Average	Record
Sea Level Pressure	30.07 in		
Wind			
Wind Speed	4 mph (WNW)		
Max Wind Speed	10 mph		
Max Gust Speed	17 mph		
Visibility	10 miles		
Events			

T = Trace of Precipitation, MM = Missing Value

Source: NWS Daily Summary

Daily Weather History Graph

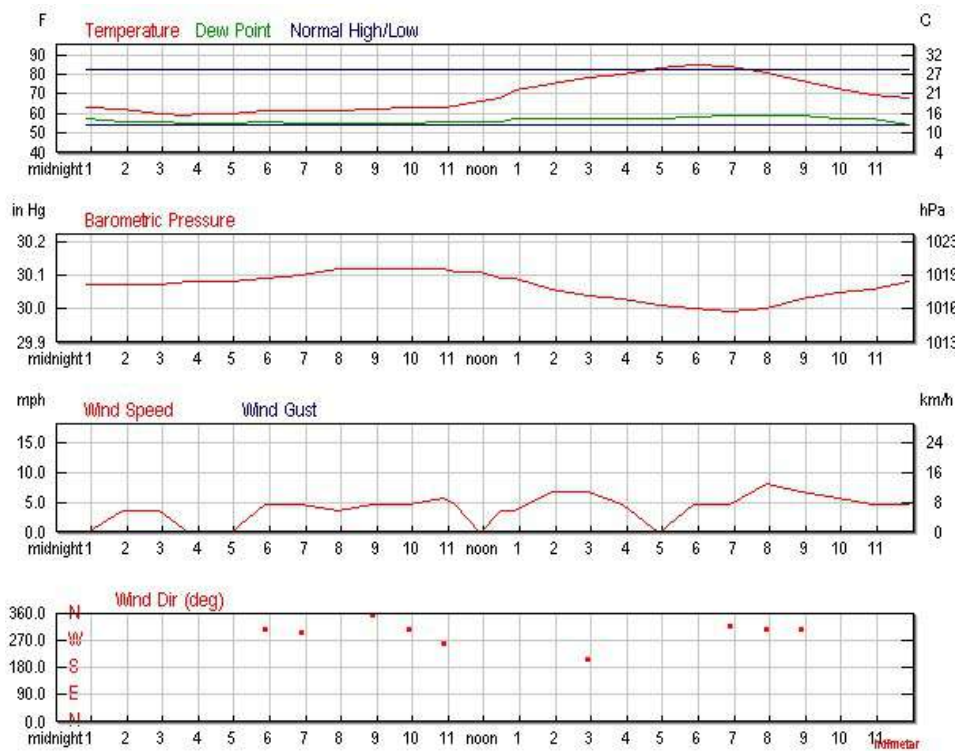

report this ad | why ads?

Search for Another Location

Airport or City:

KTTD

Submit

Trip Planner

Search our weather history database for the weather conditions in past years. The results will help you decide how hot, cold, wet, or windy it might be!

Date:

August

16

**Submit**

[report this ad](#) | [why ads?](#)

## Astronomy

Aug. 16, 2016	Rise	Set
Actual Time	6:12 AM PDT	8:14 PM PDT
<a href="#">Civil Twilight</a>	5:39 AM PDT	8:46 PM PDT
<a href="#">Nautical Twilight</a>	5:00 AM PDT	9:25 PM PDT
<a href="#">Astronomical Twilight</a>	4:16 AM PDT	10:09 PM PDT
Moon	7:10 PM PDT [8/16]	4:20 AM PDT [8/16]
<a href="#">Length of Visible Light</a>	15h 06m	
<a href="#">Length of Day</a>	14h 02m	

**Waxing Gibbous, 97%** of the Moon is Illuminated

Aug 16	Aug 18	Aug 24	Sep 1	Sep 9
Waxing Gibbous	Full	Last Quarter	New	First Quarter

[report this ad](#) | [why ads?](#)

## Hourly Weather History & Observations

Time (PDT)	Temp.	Heat Index	Dew Point	Humidity	Pressure	Visibility	Wind Dir	Wind Speed	Gust Speed	Precip	Events	Conditions
12:53 AM	63.0 °F	-	57.0 °F	81%	30.07 in	10.0 mi	Calm	Calm	-	N/A		Clear
1:53 AM	62.1 °F	-	55.9 °F	80%	30.07 in	10.0 mi	Variable	3.5 mph	-	N/A		Clear
2:53 AM	60.1 °F	-	55.9 °F	86%	30.07 in	10.0 mi	Variable	3.5 mph	-	N/A		Clear
3:45 AM	59.0 °F	-	55.0 °F	87%	30.08 in	10.0 mi	Calm	Calm	-	N/A		Mostly Cloudy
3:53 AM	60.1 °F	-	55.0 °F	83%	30.08 in	10.0 mi	Calm	Calm	-	N/A		Mostly Cloudy
4:53 AM	60.1 °F	-	55.0 °F	83%	30.08 in	10.0 mi	Calm	Calm	-	N/A		Overcast
5:53 AM	61.0 °F	-	55.9 °F	83%	30.09 in	10.0 mi	NW	4.6 mph	-	N/A		Overcast



Time (PDT)	Temp.	Heat Index	Dew Point	Humidity	Pressure	Visibility	Wind Dir	Wind Speed	Gust Speed	Precip	Events	Conditions
6:53 AM	61.0 °F	-	55.0 °F	81%	30.10 in	10.0 mi	WNW	4.6 mph	-	N/A		Overcast
7:53 AM	61.0 °F	-	55.0 °F	81%	30.12 in	10.0 mi	Variable	3.5 mph	-	N/A		Overcast
8:53 AM	62.1 °F	-	55.0 °F	78%	30.12 in	10.0 mi	North	4.6 mph	-	N/A		Overcast
9:53 AM	63.0 °F	-	55.0 °F	75%	30.12 in	10.0 mi	NW	4.6 mph	-	N/A		Overcast
10:53 AM	63.0 °F	-	55.9 °F	78%	30.12 in	10.0 mi	West	5.8 mph	-	N/A		Overcast
11:11 AM	64.0 °F	-	55.9 °F	75%	30.11 in	10.0 mi	Variable	4.6 mph	-	N/A		Overcast
11:53 AM	66.0 °F	-	55.9 °F	70%	30.11 in	10.0 mi	Calm	Calm	-	N/A		Overcast
12:27 PM	68.0 °F	-	55.9 °F	65%	30.09 in	10.0 mi	Variable	3.5 mph	-	N/A		Scattered Clouds
12:53 PM	72.0 °F	-	57.0 °F	59%	30.09 in	10.0 mi	Variable	3.5 mph	-	N/A		Scattered Clouds
1:53 PM	75.0 °F	-	57.0 °F	53%	30.06 in	10.0 mi	Variable	6.9 mph	-	N/A		Clear
2:53 PM	78.1 °F	-	57.0 °F	48%	30.04 in	10.0 mi	SSW	6.9 mph	-	N/A		Clear
3:53 PM	80.1 °F	80.4 °F	57.0 °F	45%	30.03 in	10.0 mi	Variable	4.6 mph	-	N/A		Clear
4:53 PM	82.9 °F	82.4 °F	57.0 °F	41%	30.01 in	10.0 mi	Calm	Calm	-	N/A		Clear
5:53 PM	84.9 °F	84.2 °F	57.9 °F	40%	30.00 in	10.0 mi	Variable	4.6 mph	-	N/A		Clear
6:53 PM	84.0 °F	83.8 °F	59.0 °F	43%	29.99 in	10.0 mi	NW	4.6 mph	-	N/A		Clear
7:53 PM	81.0 °F	81.3 °F	59.0 °F	47%	30.00 in	10.0 mi	NW	8.1 mph	-	N/A		Clear
8:53 PM	77.0 °F	-	59.0 °F	54%	30.03 in	10.0 mi	NW	6.9 mph	-	N/A		Clear
9:53 PM	73.0 °F	-	57.0 °F	57%	30.05 in	10.0 mi	Variable	5.8 mph	-	N/A		Clear
10:53 PM	69.1 °F	-	57.0 °F	65%	30.06 in	10.0 mi	Variable	4.6 mph	-	N/A		Clear
11:53 PM	68.0 °F	-	54.0 °F	61%	30.08 in	10.0 mi	Variable	4.6 mph	-	N/A		Clear

||

report this ad

# MODEL 21 NON-CATALYTIC UNIT

With



Motor

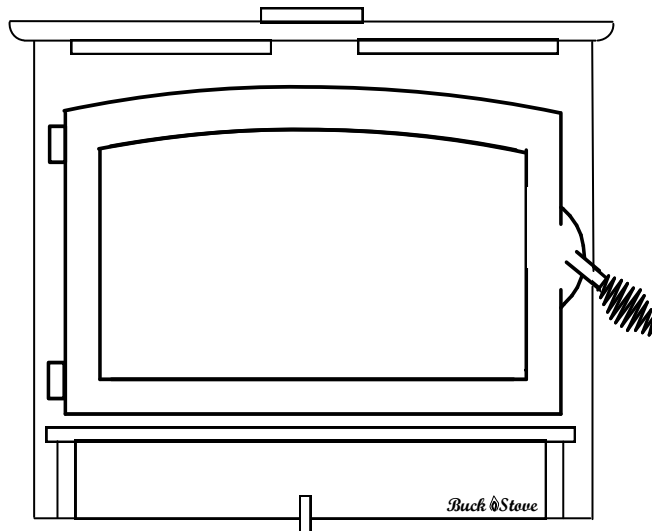

## FIREPLACE INSERT & FREESTANDING

### FEATURES

PREPARATIONS  
OPERATION

INSTALLATION  
MAINTENANCE

SAFETY

## SAFETY NOTICE

IF THIS HEATER IS NOT PROPERLY INSTALLED, A HOUSE FIRE MAY RESULT. FOR YOUR SAFETY, FOLLOW THE INSTALLATION INSTRUCTIONS. CONTACT THE AUTHORITY HAVING JURISDICTION (SUCH AS MUNICIPAL BUILDING DEPARTMENT, FIRE DEPARTMENT, FIRE PREVENTION BUREAU, etc.) CONSULT BEFORE INSTALLATION TO DETERMINE THE NEED TO OBTAIN A PERMIT. KEEP THESE INSTRUCTIONS FOR FUTURE USE.

LISTED BY:



PFS/TECO, COTTAGE GROVE, WI

MANUFACTURED BY NEW BUCK CORPORATION  
200 ETHAN ALLEN DRIVE  
P.O. BOX 69  
SPRUCE PINE, N.C. 28777  
www.buckstove.com

Revised November 2021



# TABLE OF CONTENTS

Important Instructions.....	2
Stove Parts Identification.....	3
SECTION I: Introduction .....	4
Chimney Heights .....	5
SECTION II: Masonry Insert Installation.....	6
Floor Protection .....	7
Mounting Trim Panels .....	8-9
Masonry Insert Installation options .....	10-11
SECTION III: Pre-Fab Insert Installation.....	13
SECTION IV: Residential Freestanding Installation.....	14
Out Side Air Installation.....	15
Floor Protection .....	16
Residential Installation	
A. Vertical Exit Using Single Wall Pipe /Listed 2100° UL 103 HT chimney w/out Close Clearance/Pipe Shield.....	17
B. Vertical Wall Exit Using Single Wall Pipe and Elbow /Listed 2100° UL 103 HT Chimney and T-BOX assembly w/out Close Clearance/Pipe Shields .....	19
Residential and Mobile Home Freestanding Installation (See Page 12) For Out Side Air Installation.	
C. Vertical Exit Using DVL Close Clearance Pipe /Listed 2100° UL 103 HT chimney w/out Close Clearance/Pipe Shields .....	21
D. Vertical Wall Exit Using DVL Close Clearance Pipe ,and Elbow /Listed 2100° UL 103 HT Chimney and T-BOX assembly w/out Close Clearance/Pipe Shields .....	23
E. Vertical Exit Using DVL Close Clearance Pipe /Listed 2100° UL 103 HT chimney with Close Clearance/Pipe Shields .....	25
F. Vertical Wall Exit Using DVL Close Clearance Pipe ,and Elbow /Listed 2100° UL 103 HT Chimney and T-BOX assembly with Close Clearance/Pipe Shields .....	27
SECTION V: Alcove Installation .....	31
Floor Protection .....	32
Alcove Installation Clearances .....	33
Installation of Close Clearance Shields .....	35
Wood Heater Safety.....	37
SECTION VI: Operation and Efficiency .....	38
Guide To Burning Qualities of Wood.....	39
Replacement Motor, Thermostat, Rheostat Installation .....	40-42
SECTION VII Maintenance: Brick Layout .....	43
Secondary Air Tube Replacement / Baffle Board Replacement .....	44
Door Gasket Replacement .....	45
Check Chimney / Cleaning Heater / Care of Glass Door .....	46
Troubleshooting.....	48-49
Replacement parts.....	49-50
LIMITED WARRANTY	

# INSTALLATION AND OPERATION

## IMPORTANT INSTRUCTIONS

### WARNING

THESE UNITS GENERATE A LOT OF HEAT, SO TREAT THEM WITH CARE. **HOT WHILE IN OPERATION.** KEEP CHILDREN, CLOTHING AND FURNITURE AWAY. CONTACT MAY CAUSE SKIN BURNS. READ ALL INSTRUCTIONS BEFORE INSTALLING AND USING THE APPLIANCE. FAILURE TO FOLLOW INSTRUCTIONS MAY RESULT IN PROPERTY DAMAGE, BODILY INJURY OR EVEN DEATH. SAVE THESE INSTRUCTIONS FOR FUTURE REFERENCES.

- The New Buck Corp. non-catalytic systems have been tested to UL 1482 Standards and certified by PFS/TECO.
- **When burning any unit or appliance that combusts fuel for heat, such as coal, oil, wood or natural and (L.P.) liquid petroleum gas, we highly recommend use of smoke and carbon monoxide detectors in your home. Correctly place monitors in those areas that are expected to produce CO. Consult with your local fire safety officials to learn more.**
- **This wood heater needs periodic inspection and repair for proper operation. It is against federal regulations to operate this wood heater in a manner inconsistent with operating instructions in this manual.**
- Early signs of carbon monoxide poisoning resemble flu, with headaches, dizziness and/or nausea. If you have these signs, heater may not be working properly. Get fresh air at once!
- Install and operate your units according to instructions provided in this manual. Local building codes may apply; therefore, contact your local building inspector or fire marshal for necessary installation requirements and permits which may go beyond these instructions. The authority having jurisdiction should be consulted before installation to determine the need to obtain a permit. Contact your insurance company for coverage and installation inspection.
- If appliance is installed in permanently manufactured homes:  
DO NOT INSTALL IN SLEEPING ROOMS.
- The Model 21 is approved for use in specified Pre-Fabricated fireplaces (ZCF's). Use the list on Page 13 or contact your dealer for additional units.
- Examine the masonry fireplace and chimney prior to installation of the fireplace accessory to determine that the construction meets the minimum fireplace construction requirements illustrated in the instructions, that it is free from cracks, loose mortar, creosote deposits and other blockage or other signs of deterioration.

### CAUTION

DO NOT USE MORE THAN ONE STOVE TO A CHIMNEY. DO NOT USE A FLUE INTENDED FOR A GAS APPLIANCE. DO NOT CONNECT THIS UNIT TO A CHIMNEY FLUE SERVING ANOTHER APPLIANCE. DO NOT CONNECT TO ANY AIR DISTRIBUTION DUCT OR SYSTEM.

## EPA COMPLIANCE STATUS

This manual describes installation and operation of the **New Buck Corporation Model 21** wood heater. This heater meets the U.S. Environmental Protection Agency's Emission limits for wood heaters and is in compliance with 2020 particulate emission standard. Under specific test conditions, this heater has been shown to deliver heat at rates ranging from approximately 11,079-28,901 BTU/hr for the Model 21. Efficiency was calculated using CSA B415-1.10 stack loss method. A weighted average was used to calculate the overall efficiency across all of the 4 burn rate categories using the higher heating value (HHV).

## MODEL 21 WOOD STOVE IDENTIFICATION

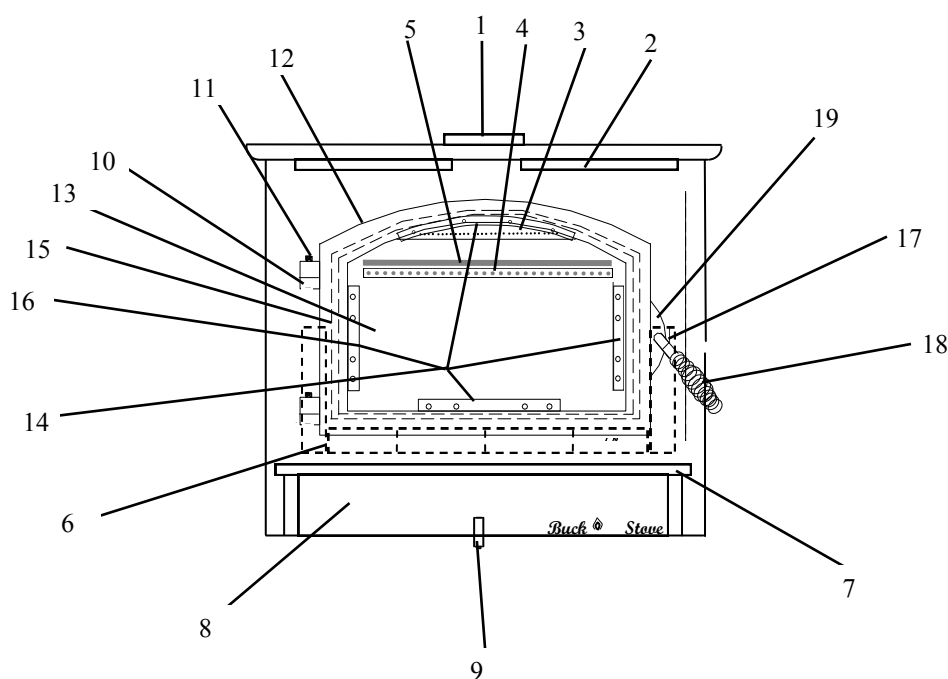

- |  |                                    |
|--|------------------------------------|
| 1. 6" Flue Exit                          | 15. Door Gasket                    |
| 2. Warm Air Outlets                      | 16. Door Glass Gasket              |
| 3. Air Wash and Screen                   | 17. Door Handle                    |
| 4. Secondary Air Tubes                   | 18. Spring Handle                  |
| 5. Top Baffle Board                      | 19. -Door Latch                    |
| 6. Firebrick                             | -Door Latch Screw                  |
| 7. Hearth Extension and Hearth Trim      | -Door Handle Bushing               |
| 8. Cover Door                            | -Door Handle Spacer                |
| 9. Primary Air Control                   | -Door Latch Flat Washer            |
| 10. Hinge Block                          | -Door Latch Screws (Phillips Head) |
| 11. Hinge Pins                           | -Door Latch Screws (Allan Head)    |
| 12. Cast Door                            |                                    |
| 13. Door Glass                           |                                    |
| 14. Glass Clips Small; Side, Top, Bottom |                                    |

## CAUTION

YOUR CHIMNEY OR FLUE MUST BE CORRECTLY SIZED. A CHIMNEY OR FLUE THAT IS TOO SMALL OR LARGE IN DIAMETER, OR TOO SHORT, CAN CAUSE YOUR STOVE TO SPILL SMOKE WHEN DOOR IS OPENED.

## SECTION I

### INTRODUCTION

Your new MODEL 21 is a non-catalytic unit designed to meet the most stringent emissions standards without the use of a catalytic combustor. This effect is achieved through the use of secondary air which is mixed with primary air in the unit's firebox.

For peak performance, we suggest the use of hard seasoned natural wood, loading wood length way from front to rear.

NOTE: Soft woods such as pine, create more creosote, clogging of chimney and produce a less efficient burn performance.

You should not burn trash or garbage, artificial or paper logs, gift wrapping, treated or painted wood or any type of coal.

**DO NOT USE CHEMICALS OR FLUIDS TO START THE FIRE.  
DO NOT BURN GARBAGE OR FLAMMABLE FLUIDS.”**

The primary air, which is controlled by the user, burns the wood. Secondary air is admitted into firebox through secondary air tubes at top of the firebox. This secondary air burns impurities in the smoke released from initial wood burning. The temperature necessary for this combustion is maintained through the firebrick refractory. If any more technical information is necessary, contact your local dealer.

A factory-built prefabricated chimney may be used for your unit when installed in compliance with the manufacturer's specification and uniform building code.

# CHIMNEY HEIGHTS

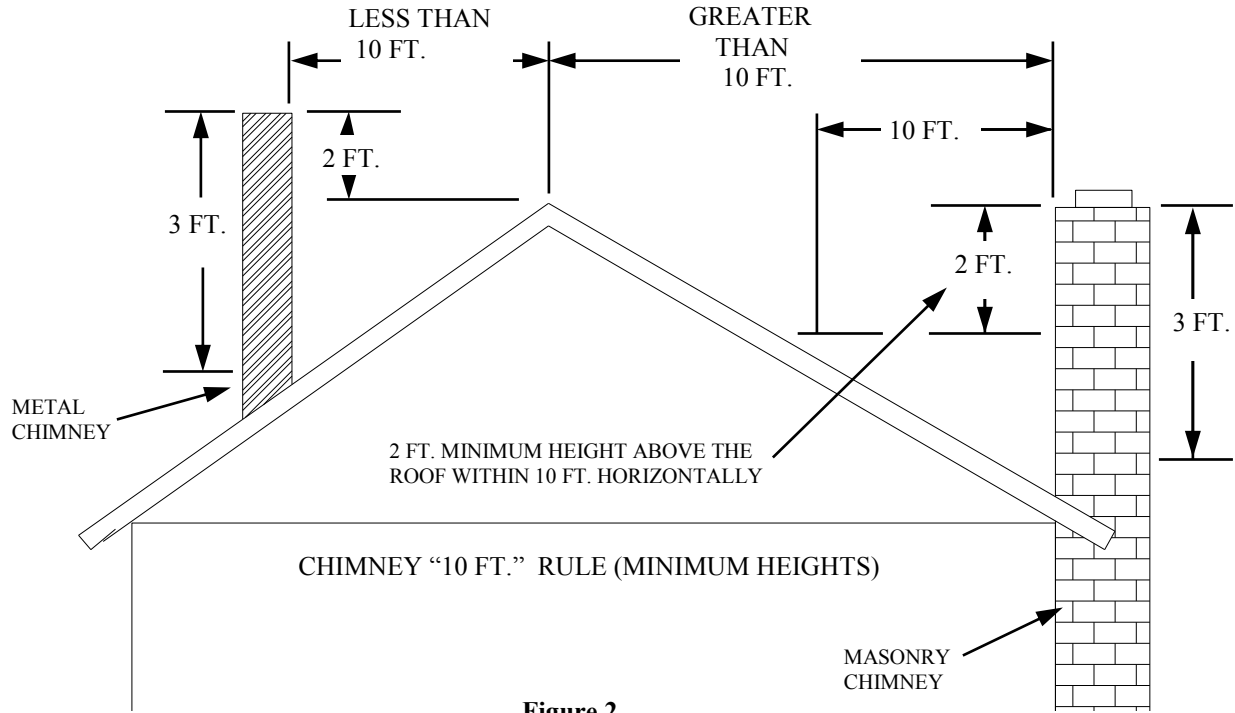
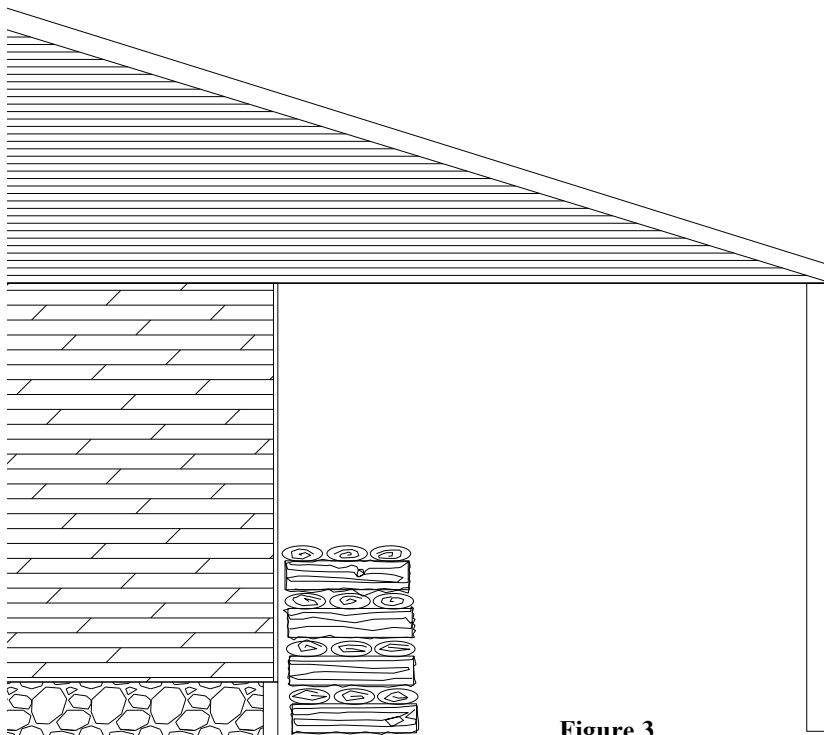

Figure 2

NOTE: MINIMUM CHIMNEY HEIGHT 15 FT.

# HOW TO STACK WOOD



Stack wood in criss-cross pattern under a shelter to allow air flow to dry wood and to keep wood from rain. Green wood may have 50-60% moisture content. Wood seasoned outside uncovered may have 40% moisture content. Wood properly seasoned in a covered environment will have less than 20% moisture content.

Figure 3



## SECTION II

### MASONRY INSERT INSTALLATION

The Model 21 may be installed using an all masonry fireplace built in accordance with the Uniform Building Code and National Fire Protection Association (NFPA). The first step in this type of installation is to determine the acceptability of fireplace and chimney for use with a woodstove. Both construction and condition of fireplace are important considerations when installing a woodstove. The chimney should extend at least 3' above roof and at least 2' above any point of the roof within 10'. (See Page 5, Figure 3).

### CAUTION

REMEMBER TO HAVE YOUR CHIMNEY INSPECTED FOR LEAKS AND BLOCKAGE **BEFORE** YOU INSTALL YOUR STOVE. DO NOT CONNECT THIS UNIT TO A CHIMNEY FLUE SERVING ANOTHER APPLIANCE.

### MINIMUM CLEARANCES TO FLOOR AND COMBUSTIBLES

#### MINIMUM CLEARANCE MASONRY INSERT

##### MODEL 21

A. Side Wall Combustible	25"
B. Front Floor Protector	16"
C. Side Floor Protector	8"
D. Side Wood Trim	17"
E. Top Wood Trim	17"
F. Mantel or Brackets	25"

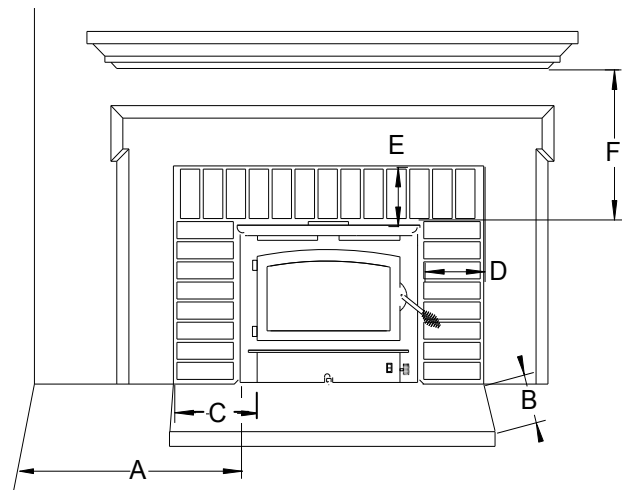

Figure 4

1. The hearth must be of masonry construction and must extend a minimum of 16" in front of firebox opening and a minimum of 8" to either side of the firebox opening. (See Figure 4).
2. If there is not minimum hearth protection from the front of firebox opening and front of masonry hearth, a floor protector must be used in front of hearth to protect combustible materials. The floor protector must be 3/8" minimum thickness non-combustible material or equivalent. (See Page 7).

## Floor Protection:

When installing freestanding heater, a floor protector must be use. Floor protector must be 3/8” minimum thickness non-combustible material or equivalent.

### How to use alternate materials and how to calculate equivalent thickness

An easy means of determining if a proposed alternate floor protector meets requirements listed in the appliance manual is to follow this procedure:

1. Convert specification to R-value:
  - R-value is given—no conversion is needed.
  - K-factor is given with a required thickness (T) in inches:  
C-factor is given:  $R=1/C$
2. Determine the R-value of the proposed alternate floor protector.
  - Use the formula in step (1) to convert values not expressed as “R”
  - For multiple layers, add R-values of each layer to determine the overall R-value.
3. If the overall R-value of the system is grater than the R-value of the specified floor protector, the alternate is acceptable.

#### Example:

The specified floor protector should be 3/4” thick material with a K-factor of 0.84.

The proposed alternate is 4” brick with a C-factor of 1.25 over 1/8” mineral board with a K-factor of 0.29.

Step (a): Use formula above to convert specification to R-value.  $R= 1/K \times T = 1/0.84 \times .75 = 0.893$

Step (b): Calculate R of proposed system. 4” brick of  $C=1.25$ , therefore  $R_{brick} = 1/C = 1/1.25 = 0.80$  1/8” mineral board of  $K = 0.29$ , therefore  $R_{min.bd.} = 1/0.29 \times 0.125 = 0.431$

Step (c): Compare proposed system R of 1.231 to specified R of 0.893. Since proposed system R is greater than required , the system is acceptable.

#### Definitions:

$$\text{Thermal conductance} = C = \frac{\text{Btu}}{(\text{hr})(\text{ft}^2)(\text{°F})} = \frac{\text{W}}{(\text{m}^2)(\text{°K})}$$

$$\text{Thermal conductance} = K = \frac{(\text{Btu})(\text{inch})}{(\text{hr})(\text{ft}^2)(\text{°F})} = \frac{\text{W}}{(\text{m})(\text{°K})} = \frac{(\text{Btu})}{(\text{hr})(\text{ft})(\text{°F})}$$

$$\text{Thermal conductance} = R = \frac{(\text{ft}^2)(\text{hr})(\text{°F})}{\text{Btu}} = \frac{(\text{m}^2)(\text{°K})}{\text{W}}$$

# INSTALLATION PROCEDURE (Use a Listed Direct or Positive Connect)(See Page 6).

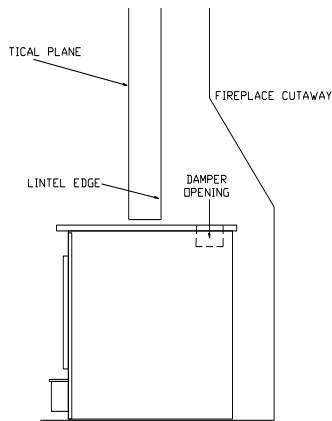

**FIGURE 5 POSITIONING**

## POSITIONING THE HEATER

**NOTE:** If the three suggested installations have been chosen, certain steps must be followed when installing heater into a masonry fireplace.

When positioning heater, the following conditions **MUST** be met! (See Figure 5).

1. The front of damper opening must be positioned **BEHIND** back edge of the lintel to ensure proper draft. (See Figure 5).
2. Center heater in fireplace opening.

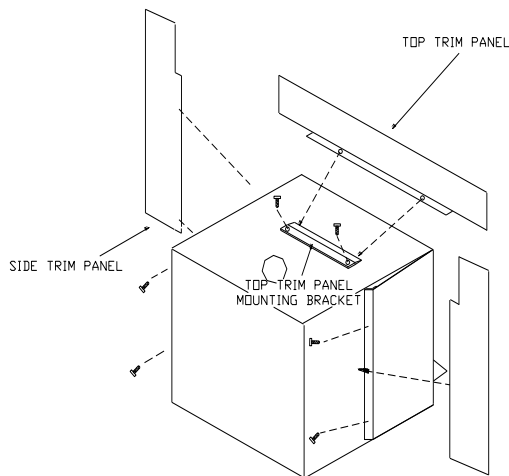

**FIGURE 6 MOUNTING TRIM PANELS**

## MOUNTING THE TRIM PANELS

After unit is positioned as shown in (Figure 8), mark mounting position of trim panels as follows:

1. Place side trim panels in place, flat against the face of the fireplace. Mark down front edge of trim panel with a pencil to make a vertical reference line. (See Figure 6).
2. Place top (long) trim panel in place on top of unit. The panel should be flat against the outside face of fireplace and standing vertically. Mark along lower edge of trim panel with a pencil to make a reference line for mounting.

3. Slide unit out of the fireplace far enough to work behind trim panel reference lines.
4. Mount side trim panels. (See Figure 6).
  - a. Position trim panel on reference line.
  - b. Drill mounting holes in center of trim panels mounting brackets to allow for adjustment in and out if necessary.
  - c. Mount trim panel using self-tapping screws provided.
5. Place top panel back on reference mark. Take top trim panel mounting bracket supplied with unit. Position bracket so it overlaps rear lip of top trim panel. Drill mounting holes in top of stove using holes in bracket as guide. Tighten down screws.
6. Now, follow installation procedures in the listed direct connect or positive connect kit you are using and install heater connect kit in the fireplace.
7. Slide unit back into fireplace. Check to be sure that trim panels are properly positioned and lie flat against front of fireplace. If one or more of the panels is out of position, slide unit out and reset by loosening mounting screws and repositioning in slot.
8. Reinstall top trim panel by sliding rear lip of top trim panel underneath front lip of mounting bracket already secured to top of unit.

**NOTE:** Mount top trim panel so that it sits in front of top of side trim panels.
9. Obtain brass trim kit provided with unit and slip over top and sides of trim panels. (Top ends of brass may need to be trimmed to fit).

10. If direct connect or positive connect kit is not used, follow instructions in *mounting trim panels, steps 1-4c* on page 10.
11. Mount top trim panel by drilling mounting holes in center of trim panel mounting brackets, with top end side of top panel overlapping side panel.
12. Using insulation provided, peel and stick to back of panels overlapping fireplace dimensions by 1" on each side and top. (See Page 8, Figure 6).
13. Next using high heat silicone or furnace cement run heavy bead of caulking around where panels meet stove. (See Figure 7).
14. Slide the unit back into fireplace. Check to be sure that trim panels (and brass) are properly positioned and lie flat against front of fireplace. If panels are out of position, slide unit out and reset by loosening mounting screws and repositioning in the slot. Using the bar, lift stove in front. Place insulation across front and the surface of hearth or bottom of fireplace, to make complete seal.
15. To check seal of panels, use candle flame and go around entire area sealed by silicone and insulation. If flame leans toward inside of fireplace, add additional insulation. This ensures an airtight seal.

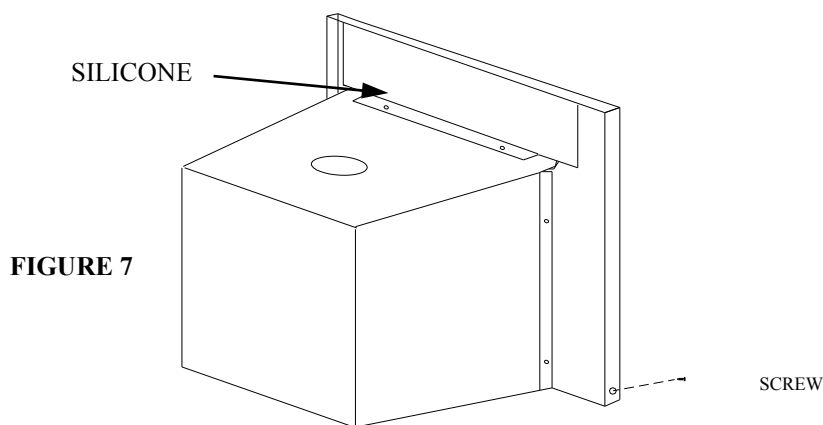

## POSSIBLE TOOLS NEEDED FOR INSTALLATION

If you decide to install your own stove, there are several hand tools you may need to do the job. If you do not already have them, they are readily available at most hardware stores.

Caulking gun

Large adjustable wrench (may not be needed)

Drop cloths or newspapers

Vacuum cleaner or whisk broom

Flashlight

1 tube of RTV silicone (Code 103 or 106, or high temperature rubber cement rated between 450° F- 600° F)

7/32" drill bit and drill

Socket/Ratchet Set

## INSTALLATION PREPARATION

1. Relocate furniture and other materials away from front of fireplace to allow free access to fireplace.
2. Cover hearth and adjacent floor areas with a drop cloths to protect from soiling or marring surface.
3. Remove existing fireplace damper plate.
4. Thoroughly clean fireplace of ashes and soot.
5. Check chimney and smoke chamber for excessive buildup of creosote or soot. Also, check for obstructions, such as birds nests. If chimney is excessively dirty, clean it or have someone clean it professionally BEFORE installing or using room heater.
6. If fireplace has an ash dump or outside air provision, these must be sealed off with metal or tightly packed non-combustible insulation to prevent cold air from entering fireplace chamber.

## MASONRY INSERT INSTALLATION OPTIONS

This unit (appliance) may be installed into an all masonry fireplace, built in accordance with the Uniform Building Code and the National Fire Protection Association (*NFPA 211*).

**NOTE:** Check with local building officials for any permits required for installation of this unit and notify your insurance company before proceeding with installation

In some cases, such as improperly drawing fireplaces, oversize flue liners are to meet codes in certain areas it is recommended that one of the following procedures be followed:

- A. A **Chimney Connector** can be installed from the appliance flue exit through the damper and an air-tight face seal. (See option (A) Page 9).
- B. A listed **Direct Connect** can be installed from the appliance flue exit through the damper into the first section of the flue liner with air-tight seal. (See option (B) Page 9).
- C. A **Positive Connect** can be installed from the appliance flue exit continuing up through the entire chimney and exiting at the top of the chimney. (See option (C) Page 9).

NOTE: If mounting trim panels, See Page 8-9.

## FINAL CHECK

1. Recheck specified clearances.
2. Remove all foreign material from firebox area.
3. Open the primary air draft.
4. Plug power cord into a 115V AC outlet if optional motor is being used. Do not run cord under unit or in high traffic areas.
5. Place crumpled pieces of newspaper in the stove. Light it and close door. Ensure that the stove draws properly through primary draft.
6. Check for smoke leaks around door.
7. Open door and check for smoke escaping from front of stove. Smoking usually indicates a defective or poorly positioned chimney. Some chimneys with a marginal draft can be preheated by lighting newspaper and holding it near open damper with a poker or fire tong. Once the chimney heats up, a proper draft can usually be obtained.

If a thorough review of the Troubleshooting Guide in the manual does not reveal the problem, contact your dealer for assistance.

**SAFETY NOTICE:** ⚠️

**If this appliance is not properly installed, a house fire may result. For your safety, follow the installation directions. Contact local building or fire officials about restrictions and installation inspection requirements in your area.**

**OPTION (A)**

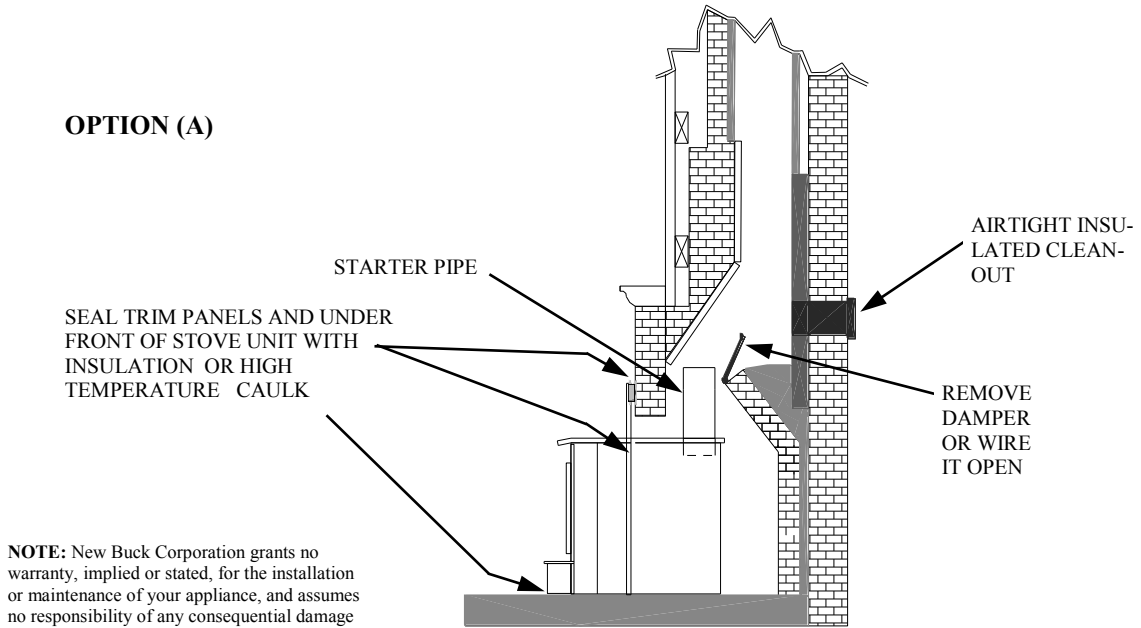

**OPTION (B)**

NOTE: Follow installation instruction with Direct Connection Kit. (Kit sold separately)

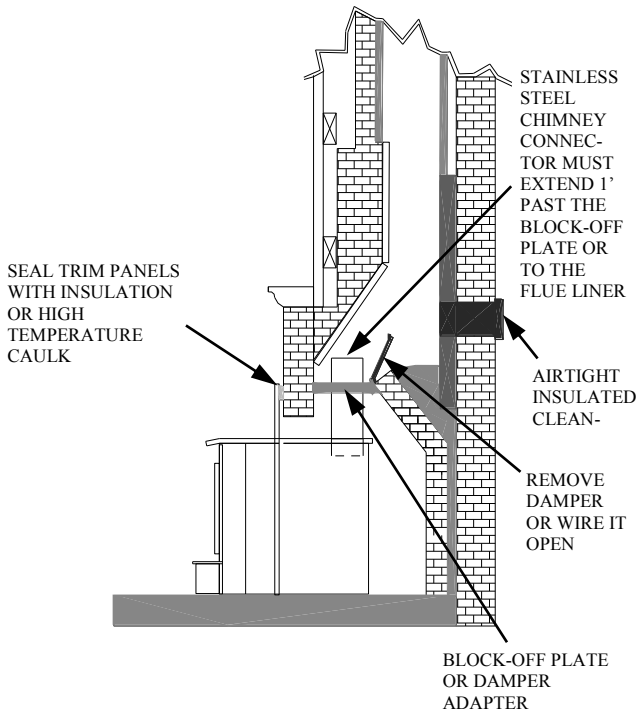

**OPTION (C)**

NOTE: Follow installation instruction with Positive Connection Kit. (Kit sold separately)

INSTALL A NON-COMBUSTIBLE COVER PLATE TO PREVENT WATER FROM ENTERING THE CHIMNEY

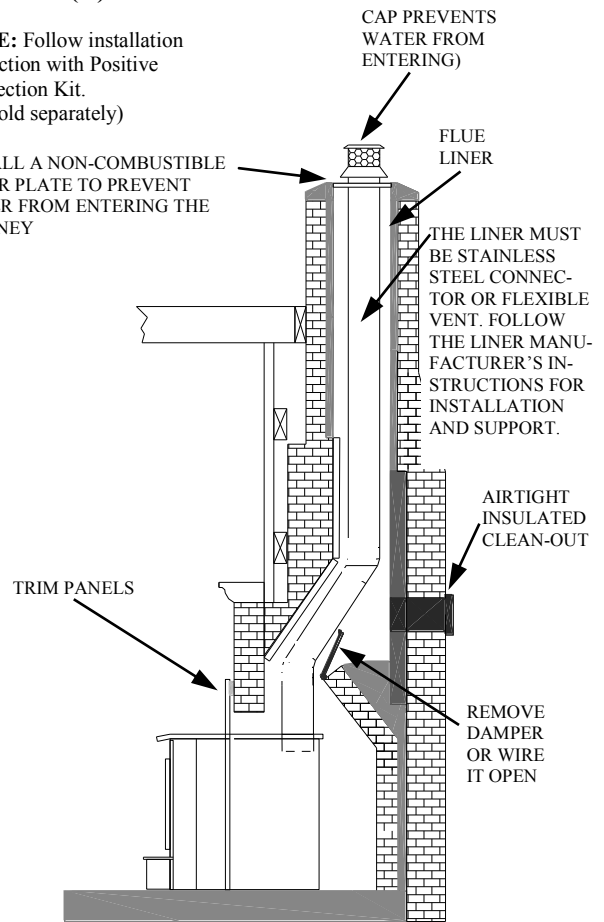

## **CAUTION**

**THE UNIT IS PAINTED WITH A SPECIALLY FORMULATED HIGH TEMPERATURE PAINT THAT CURES DURING THE FIRST TWO OR THREE FIRINGS. YOU MAY NOTICE A SLIGHT SMOKING EFFECT AND AN ODOR OF BURNING PAINT WHEN YOU BUILD THE FIRST FIRES. THIS IS NORMAL AND IS NOT A CAUSE FOR ALARM. IN SOME CASES, THESE FUMES WILL ACTIVATE A SMOKE ALARM. OPENING A WINDOW NEAR THE UNIT WILL ALLOW THESE FUMES TO ESCAPE. DO NOT BUILD A LARGE, ROARING FIRE UNTIL THIS CURING IS COMPLETE OR THE HEATER FINISH MAY BE DAMAGED.**

The connector and/or chimney should be inspected at least once a month during the heating season to determine if a creosote buildup has occurred.

## **CAUTION**

**NEVER USE GASOLINE, GASOLINE-TYPE LANTERN FUEL, KEROSENE, CHARCOAL LIGHTER FLUID OR SIMILAR LIQUIDS TO START OR "FRESHEN UP" A FIRE IN THE HEATER. KEEP ALL SUCH LIQUIDS WELL AWAY FROM THE STOVE WHEN IT IS IN USE. ALL FLUIDS OF THIS TYPE GIVE OFF VOLATILE FUMES AND CAN AND WILL EXPLODE! DON'T TAKE A CHANCE WITH THE SAFETY OF YOUR HOME AND FAMILY.**

## SECTION III

### PRE-FAB INSERT INSTALLATION

The Model 21 has been tested with the following:

Heatilator	Security
Tempco	Preway
Marco	FMI
Woodside	Majestic

NOTE: The Model 21 may be installed in any of the pre-fabricated fireplaces listed above if they are big enough to accept heater.

NOTE: A FULL CHIMNEY LINER IS REQUIRED IN A ZERO CLEARANCE OR PRE - FABRICATED FIREPLACE.

NOTE: The ash lip, smoke baffle and smoke shelf may be removed if necessary to provide room for these models. Any other alteration to unit will void ALL NEW BUCK CORPORATION, responsibility and liability. The warning label below must be attached to the pre- fabricated fireplace before unit is installed.

Except for the “notes” above, please follow the instructions for Masonry Insert Installation including Minimum Clearances for stove and floor protector in Section II.

NOTE: When installing trim panels DO NOT COVER ANY EXITING LOUVERS OR AIR OPENING IN PRE-FABRICATED FIREPLACE .

**WARNING: This fireplace must be restored to its original condition for safe use, if the fireplace insert is removed.**



## SECTION IV

# RESIDENTIAL FREESTANDING INSTALLATION

### TOOLS FOR INSTALLATION

Drop cloth, 3/32" Metal drill bit, 5/16" magnetic socket chuck adapter, 5/16" wrench (box or socket) or adjustable wrench, Jigsaw with masonry, metal and wood blades

**WARNING: DO NOT INSTALL IN A SLEEPING ROOM**

### PREPARING THE STOVE FOR INSTALLATION

1. Remove the protective plastic wrapping from unit, inspect unit for any obvious physical damage.
2. Plug power cord into a 115V AC outlet to test motor and fan when optional motor is being used. Do not run cord under unit or in high traffic areas.
3. Check primary air draft control to ensure that it slides freely.(See Figure 11).
4. Remove any items from within firebox. Spread a dropcloth on floor behind heater. Next, tilt heater so that back is on drop cloth.
5. **(Leg Kit):** If legs are to be used, obtain four legs, attach legs to holes in bottom of unit with bolts and washers supplied with the leg kit. (See Figure 11).
6. **(Pedestal Kit):** If pedestal kit is being used an outside air is required, see *Out Side Air Installation* below. Open freestanding kit and obtain stand. Place stand against bottom of heater (angle side to heater). Center stand front to back and also center stand left and right. Mark screw locations on bottom of stove through outer holes of stand mounting angles. Set stand aside and drill four 7/32" holes in heater bottom. Before attaching heater to stand, take a large flat screwdriver or pliers and remove the 2" x 2" knockout on bottom of unit. (See Figure 12). Then mount stand to bottom of heater with screws provided. (See Figure 12).
7. Obtain four (4) 3/16" self-tapping screws and secure stand to heater.
8. Reposition heater to the upright position.

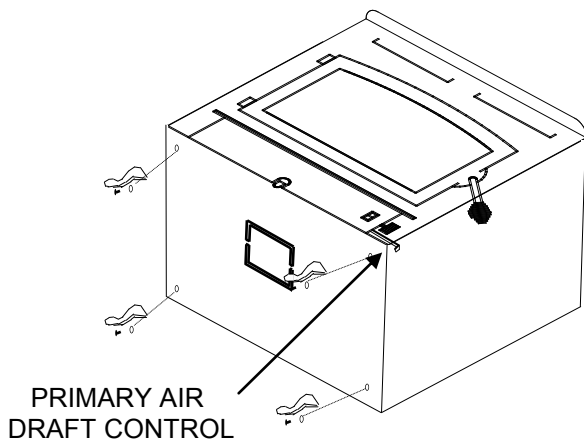

Figure 11

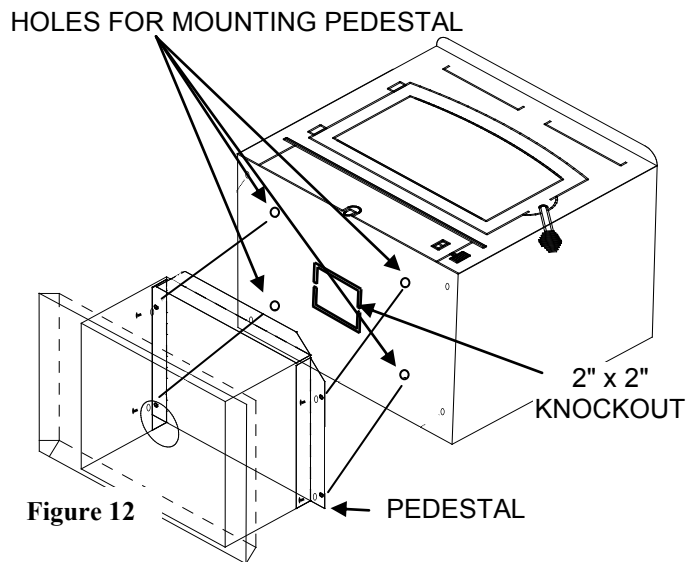

Figure 12

### Out Side Air Installation

## CAUTION

**THE STRUCTURAL INTEGRITY OF THE MOBILE HOME FLOOR MUST BE MAINTAINED. (MOVE OPENING AND/OR REPOSITION HEATER LOCATION IF NECESSARY).**

1. Select an installation location that gives the best airflow from the front of heater to remainder of home.
2. Place protective floor pad in position. For minim floor protection (See Page 16).

3. Place unit on pad making sure minimum clearance specifications are met.
4. Lightly mark with a pencil the location of pedestal on protective pad.
5. Next, remove the four (4) screws holding heater to stand. Position heater out of the way of installation area.
6. Check that pedestal stand is still aligned with marks on the protective pad, now mark outside air opening in bottom of pedestal stand on to the pad.
7. Mark center line of outside air opening. Set stand aside for now.
8. Cut a 4 1/4" diameter hole in pad and continue through floor.  
**CAUTION. The structural integrity of mobile home floor must be maintained.**  
(Move opening and/or reposition heater location if necessary).
9. Now, reposition pedestal stand on pad being sure to line stand up with reference marks on pad.
10. Using an electric drill and 3/8" masonry bit, drill four (4) holes in the protective pad using holes in the bottom of the pedestal stand as a guide. Be careful to drill only through pad and not into floor. Change the bit to a 1/4" metal bit and drill through floor.
11. Using four (4) 3/8" x 1-1/2" lag bolts provided, secure pedestal stand and pad to floor of mobile home.

## CAUTION

**IF A THICK FLOOR PROTECTOR IS USED, YOU MAY HAVE TO USE LONGER LAG BOLTS.**

12. Obtain outside air duct from the box in pedestal kit marked FA P21B.
13. Slip duct down through the 4-1/4" hole until the face of outside air duct with screen wire, contacts bottom of pedestal.
14. Secure outside air duct to inside bottom of pedestal using four (4) #10x1 screws provided. (See Figure 13).
15. Set heater back onto stand and resecure using screws.
16. NOTE: If home is underpinned, you must duct through underpin as shown. (See Figure 14).

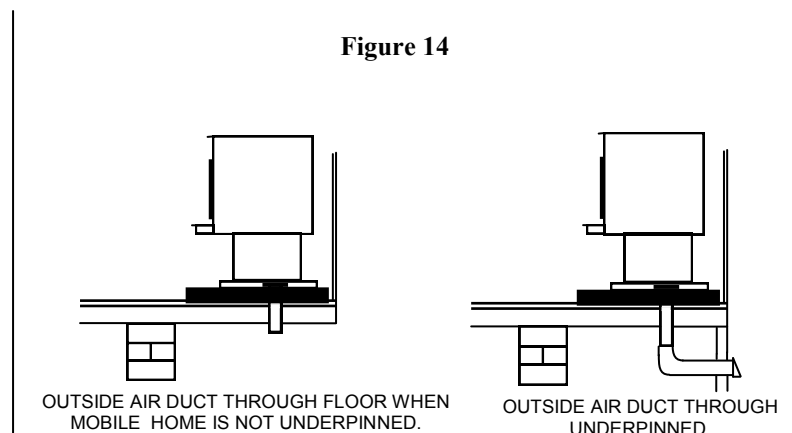
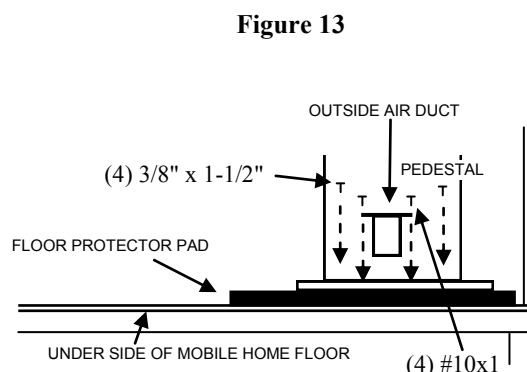

## Floor Protection:

Floor protection must be 3/8" minimum thickness non-combustible material or equivalent.

### How to use alternate materials and how to calculate equivalent thickness

An easy means of determining if a proposed alternate floor protector meets requirements listed in the appliance manual is to follow this procedure:

1. Convert specification to R-value:
  - R-value is given—no conversion is needed.
  - K-factor is given with a required thickness (T) in inches:  
C-factor is given:  $R=1/C$
2. Determine the R-value of the proposed alternate floor protector.
  - Use the formula in step (1) to convert values not expressed as "R"
  - For multiple layers, add R-values of each layer to determine the overall R-value.
3. If the overall R-value of the system is greater than the R-value of the specified floor protector, the alternate is acceptable.

#### Example:

The specified floor protector should be 3/4" thick material with a K-factor of 0.84.

The proposed alternate is 4" brick with a C-factor of 1.25 over 1/8" mineral board with a K-factor of 0.29.

Step (a): Use formula above to convert specification to R-value.  $R= 1/K \times T = 1/0.84 \times .75 = 0.893$

Step (b): Calculate R of proposed system. 4" brick of  $C=1.25$ , therefore  $R_{brick} = 1/C = 1/1.25 = 0.80$  1/8" mineral board of  $K = 0.29$ , therefore  $R_{min.bd.} = 1/0.29 \times 0.125 = 0.431$

Step (c): Compare proposed system R of 1.231 to specified R of 0.893. Since proposed system R is greater than required, the system is acceptable.

#### Definitions:

$$\text{Thermal conductance} = C = \frac{\text{Btu}}{(\text{hr})(\text{ft}^2)(\text{°F})} = \frac{\text{W}}{(\text{m}^2)(\text{°K})}$$

$$\text{Thermal conductance} = K = \frac{(\text{Btu})(\text{inch})}{(\text{hr})(\text{ft}^2)(\text{°F})} = \frac{\text{W}}{(\text{m})(\text{°K})} = \frac{(\text{Btu})}{(\text{hr})(\text{ft})(\text{°F})}$$

$$\text{Thermal conductance} = R = \frac{(\text{ft}^2)(\text{hr})(\text{°F})}{\text{Btu}} = \frac{(\text{m}^2)(\text{°K})}{\text{W}}$$

Install in accordance with 24 CFR, Part 3280 (HUD).

## Chimney

This model is designed for connection to any listed 2100° UL103 HT chimneys and parts. Follow chimney manufacturer's instructions carefully.

This room heater must be converted to (1) a chimney complying with the requirements for Type HT chimneys in the Standard for chimneys, Factory-Built, Residential, Type and Building Heating Appliance, UL 103 or (2) a code approved masonry chimney with a flue liner.

## PREPARING THE ROOM HEATER LOCATION

1. Select an installation location that will give the best airflow from the front of the heater to the remainder of the home.
2. Place the protective floor pad in position.
3. Place unit on pad making sure minimum clearance specifications are met.
4. If connecting to an existing masonry flue, first ensure that flue conforms to the **NFPA-211** Code and/or consult your local code for proper procedures.

**NOTE:** This model is designed for connection to: any Listed 2100° UL 103 HT. TYP chimney also any Listed UL DVL Close Clearance Pipe or Single wall minimum 24 ga. Blued or Black Pipe. Follow pipe manufacturer's instructions carefully.

## CHIMNEY

This room heater must be converted to (1) a chimney complying with requirements for Type HT chimneys in the Standard for Chimneys, Factory-Built, Residential, Type and Building Heating Appliance, UL 103, or (2) a code approved masonry chimney with flue liner.



**CAUTION:** Certain installation types require the use of certain chimney types. Please follow these instructions exactly.

## HOW TO LOCATE CHIMNEY EXIT AND INSTALL

### Residential Installation

#### **A. Vertical Exit using (6" Single Wall minimum 24 ga. blued or black pipe and any Listed 2100° UL 103 HT. chimney).**

**Without optional close clearance shield and pipe shield.**

**NOTE: For minimum clearances (See Page 18, Figure 15).**

1. Suspend a plumb bob from ceiling above unit so that weight is hanging in the center of flue exit. (A small weight on a string will serve as a plumb bob). Mark ceiling where string is suspended to locate center of chimney.
2. After locating center of hole, install ceiling support box, chimney or chimney connector, flashing, and rain cap, per chimney manufacturer's instructions and local building codes for installation through combustible walls or ceilings.
3. Now connect stove and ceiling support box using 6" Single Wall minimum 24 ga. blued or black pipe (**DO NOT USE GALVANIZED PIPE**). Connect each section so crimped end faces downward and secure each section to each other using at least three (3) sheet metal screws or rivets. Single wall pipe is to be connected with (3) sheet metal screws or rivets to connector collar on heater. (See Page 18, Figure 16).
4. **NOTE:** If your local code requires outside air for residential installation, refer to pages 14-15 for outside air installation.

**A. Vertical exit using (6" Single Wall minimum 24ga. blued or black pipe and any listed 2100° UL 103 HT. TYPE Chimney)  
Without optional close clearance shield and pipe shield  
Model 21 minimum clearance to combustibles**

Figure 15

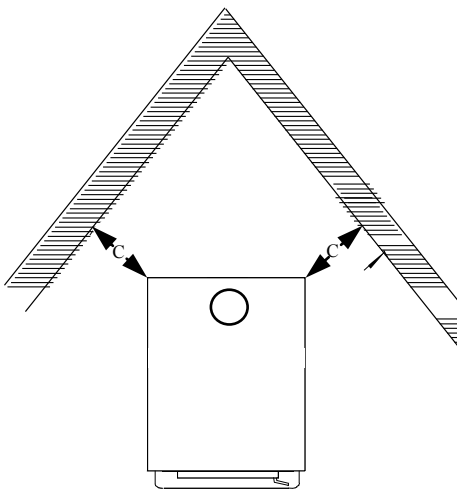
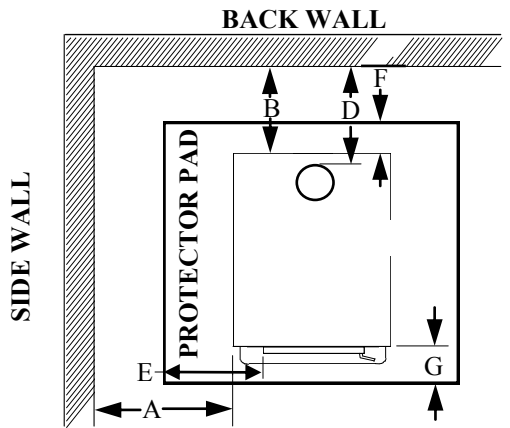

A B C D E F G

MODEL 21 25" 13" 13" 15.5" 8" 6" 16"

Figure 16

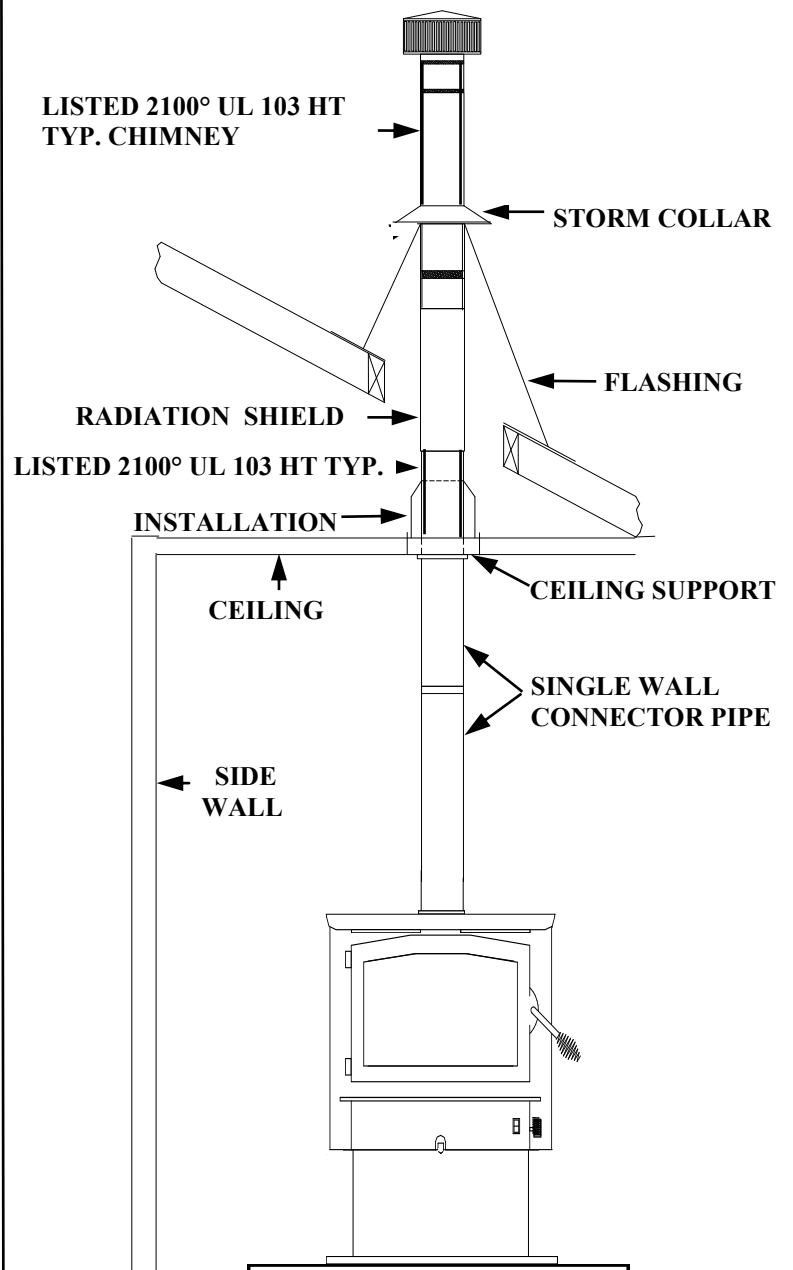

**NOTE:** All clearances are to combustibles without close clearance shields and pipe shield, using 6" Single Wall minimum 24ga. blued or black pipe and minimum floor protector. The clearances above may be reduced. Follow NFPA-211 codes if available or follow instructions on (Pages 21, 22 or Pages 25, 26).

# HOW TO LOCATE CHIMNEY EXIT AND INSTALL

## Residential Installation

- B. Vertical Wall Exit using (6" Single Wall minimum 24ga. blued or black pipe with elbow and any Listed 2100° UL HT chimney and Listed 2100° UL HT. T-Box assembly). Without optional close clearance shields and pipe shield.**

**NOTE: For minimum clearances (See Page 20, Figure 17).**

1. Mark the plumb line on wall directly behind center of heater.  
(See Page 20, Figure 18).  
**NOTE: When using 6" Single Wall minimum 24ga. blued or black pipe, maintain 18" minimum clearances" between pipe and ceiling.**
2. Place vertical portion of heater pipe and elbow in position and project a point onto plumb line level with center of elbow.
3. Measure up so there will be at least 1/4" rise per foot of horizontal connector pipe, maintaining clearances to ceiling as noted in (Page 20, Figure 18). This will give you center of hole for the chimney penetration.
4. After locating center of penetration, install tee-box and chimney, per chimney manufacturer's specifications.
5. Connect chimney collar to tee-box using 6" Single Wall minimum 24ga. blued or black pipe. (DO NOT USE GALVANIZED PIPE). Connect each section so crimped end faces downward and secure each section to each other using three (3) sheet metal screws or rivets. Single wall pipe is to be connected with three (3) sheet metal screws rivets to connector collar on heater. (See Page 20, Figure 18).
6. **NOTE: If your local code requires outside air for residential installation, refer to pages 14-15 for outside air installation.**

**B. Vertical wall exit using (6" Single Wall minimum 24ga. blued or black pipe with elbow and any listed 2100° UL 103 HT. TYPE Chimney and Listed 2100° UL HT. T-Box assembly). Without optional close clearance shield and pipe shield. Model 21 minimum clearance to combustibles.**

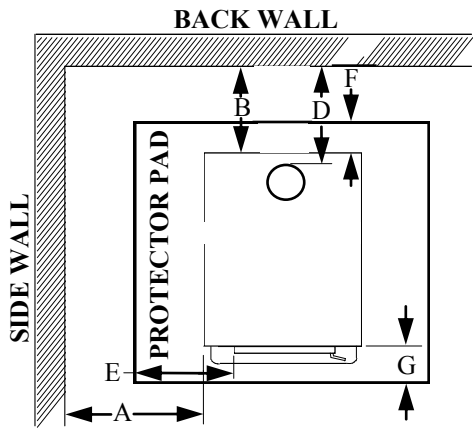
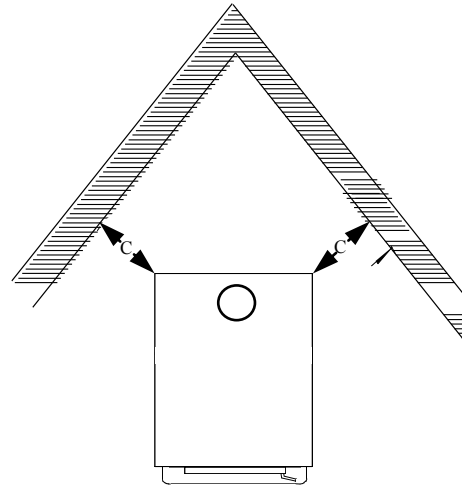

Figure 17



	A	B	C	D	E	F	G
MODEL 21	25"	13"	13"	15.5"	8"	6"	16"

**NOTE:** All clearances are to combustibles without close clearance shields and pipe shield, 6" Single Wall minimum 24ga. blued or black pipe with elbow and minimum floor protector. Clearances above may be reduced. Follow NFPA-211 codes if available or follow instructions on (Pages 23,24 or Pages 27, 28).

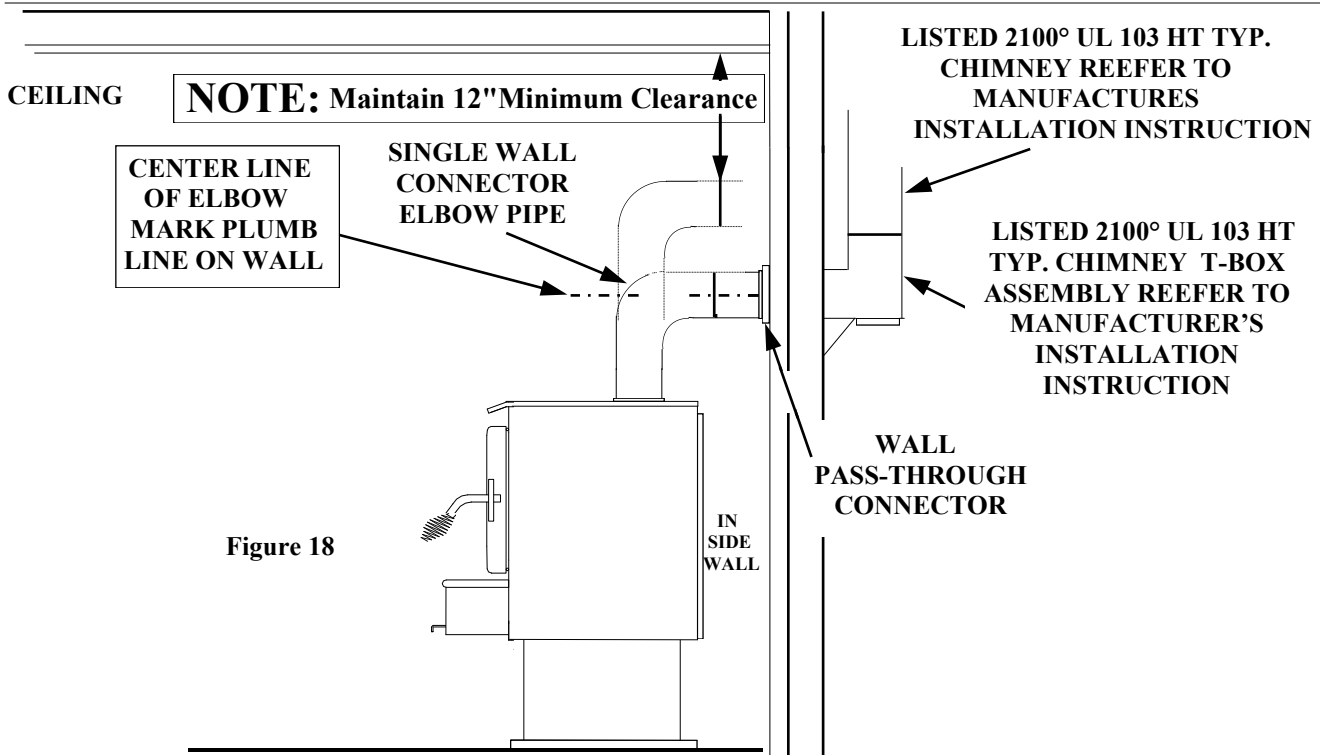

Figure 18

# HOW TO LOCATE CHIMNEY EXIT AND INSTALL

## Residential and Mobile Home Installation

### C. Vertical Exit using (6" DVL Close Clearance pipe and any Listed 2100° UL 103 HT chimney).

**Without close clearance shield and pipe shield.**

**NOTE: For minimum clearances (See Page 22, Figure 19).**

1. Suspend a plumb bob from ceiling above unit so that weight is hanging in the center of flue exit. (A small weight on a string will serve as a plumb bob). Mark ceiling where string is suspended to locate the center of chimney. (See Page 23, Figure 20).
2. After locating center of hole, install ceiling support box, chimney or chimney connector, flashing and rain cap, per chimney manufacturer's instructions and local building codes for installation through combustible walls or ceilings.
3. Now connect stove and ceiling support box using DVL close clearance pipe. Connect each section per manufacturer's instructions. Secure each section to each other using minimum (3) sheet metal screws or rivets. DVL close clearance is to be connected with (3) sheet metal screws or rivets to connector collar on heater (See Page 23, Figure 20).
4. NOTE: If your local code requires outside air for residential installation, refer to pages 14-15 for outside air installation.



**C. Vertical exit using (6" DVL Close Clearance pipe and any listed 2100° UL 103 HT. TYPE Chimney). Without optional close clearance shield and pipe shield. Model 21 minimum clearance to combustibles.**

Figure 19

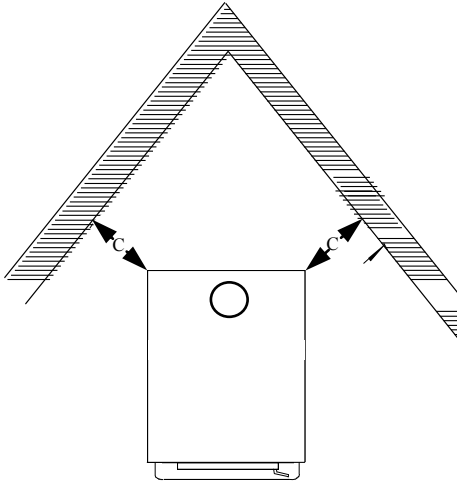
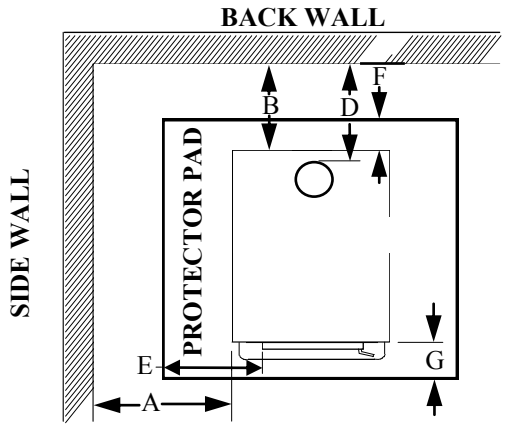

	A	B	C	D	E	F	G
MODEL 21	23"	9"	9"	10.5"	8"	6"	16"

Figure 20

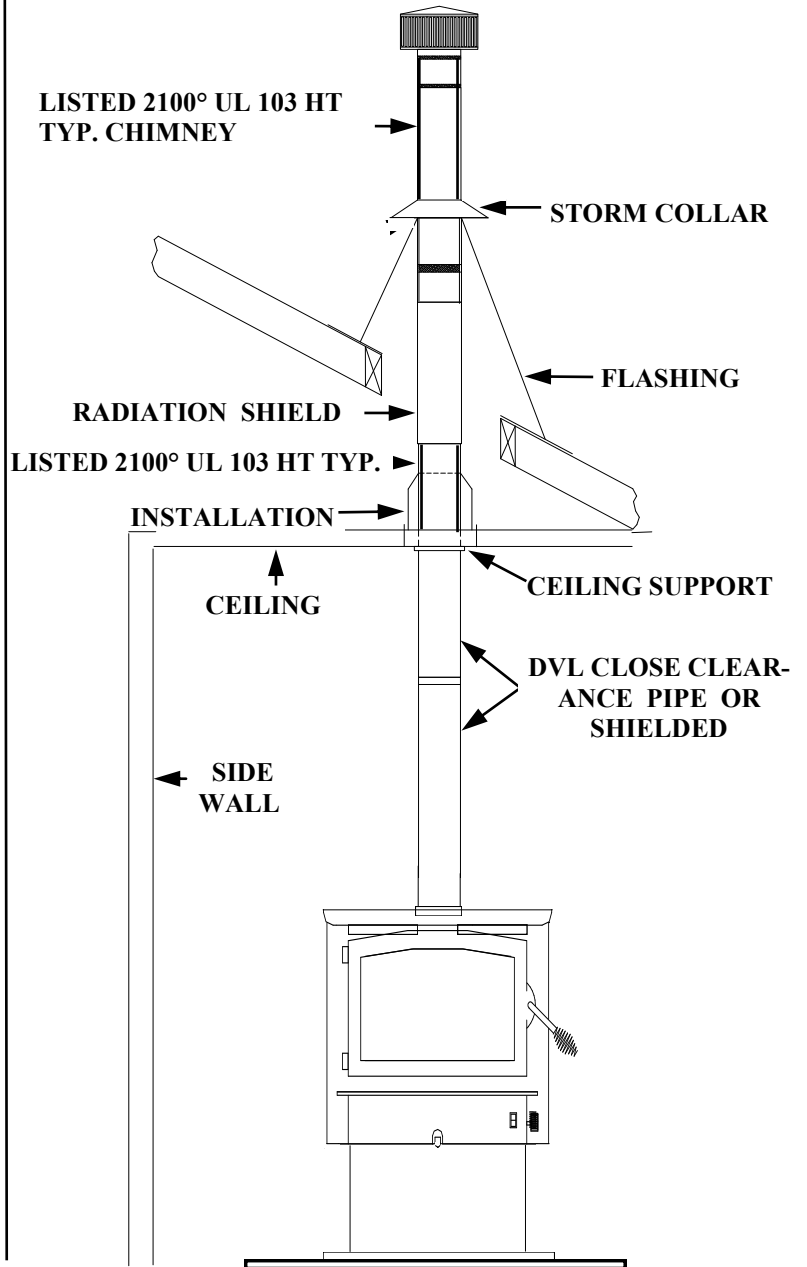

**NOTE:** All clearances are to combustibles without close clearance shields and pipe shield, using DVL Close Clearance pipe and minimum floor protector. The clearances above may be reduced. Follow NFPA-211 codes if available or follow instructions on (Pages 25 and 26).

# HOW TO LOCATE CHIMNEY EXIT AND INSTALL

## Residential and Mobile Home Installation

### D. Vertical Wall Exit using (6" DVL Close Clearance Pipe and Elbow and any Listed 2100° UL HT chimney and Listed 2100° UL HT T-Box assembly).

**Without optional close clearance shield and pipe shield.**

**NOTE: For minimum clearances (See Page 24, Figure 21).**

1. Mark the plumb line on wall directly behind center of heater.  
(See Page 24, Figure 22).  
**NOTE:** When using DVL Close Clearance Pipe, maintain manufacturer's minimum clearances between pipe and ceiling.
2. Place vertical portion of heater pipe and elbow in position and project a point onto plumb line level with center of elbow.
3. Measure up so there will be at least 1/4" rise per foot of horizontal connector pipe, maintaining clearances to ceiling as noted in (Page 24, Figure 22). This will give you center of hole for chimney penetration.
4. After locating center of penetration, install the tee-box and chimney, as per chimney manufacturer's specifications.
5. Connect the DVL close clearance pipe to tee-box, per manufacturer's instructions, DVL close clearance pipe is to be connected with (3) sheet metal screws or rivets to connector collar on heater (See Page 24, Figure 22).
6. **NOTE:** If your local code requires outside air for residential installation, refer to pages 13-14 for outside air installation.

**D. Vertical wall exit using (6" DVL Close Clearance pipe with elbow) and any listed 2100° UL 103 HT. TYPE Chimney and Listed 2100° UL HT T-Box assembly). Without optional close clearance shield and pipe shield. Model 21 minimum clearance to combustibles.**

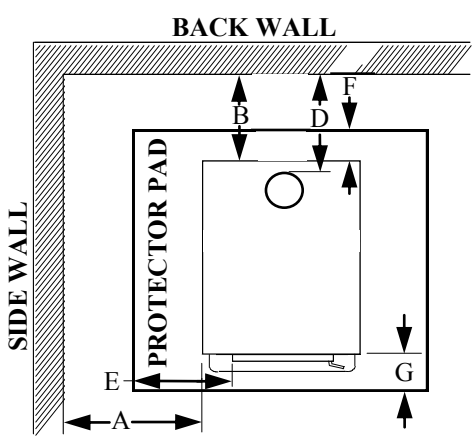
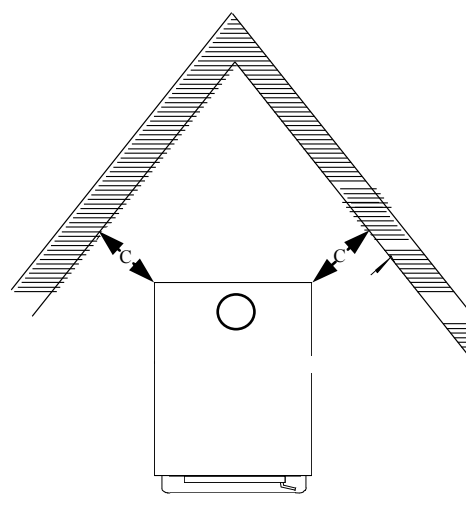

Figure 21



	A	B	C	D	E	F	G
MODEL 21	23"	9"	9"	10.5"	8"	6"	16"

**NOTE:** All clearances are to combustibles without close clearance shields and pipe shield, DVL Close Clearance pipe with elbow and minimum floor protector. The clearances above may be reduced. Follow NFPA-211 codes if available or follow instructions on (Pages 25 and 26).

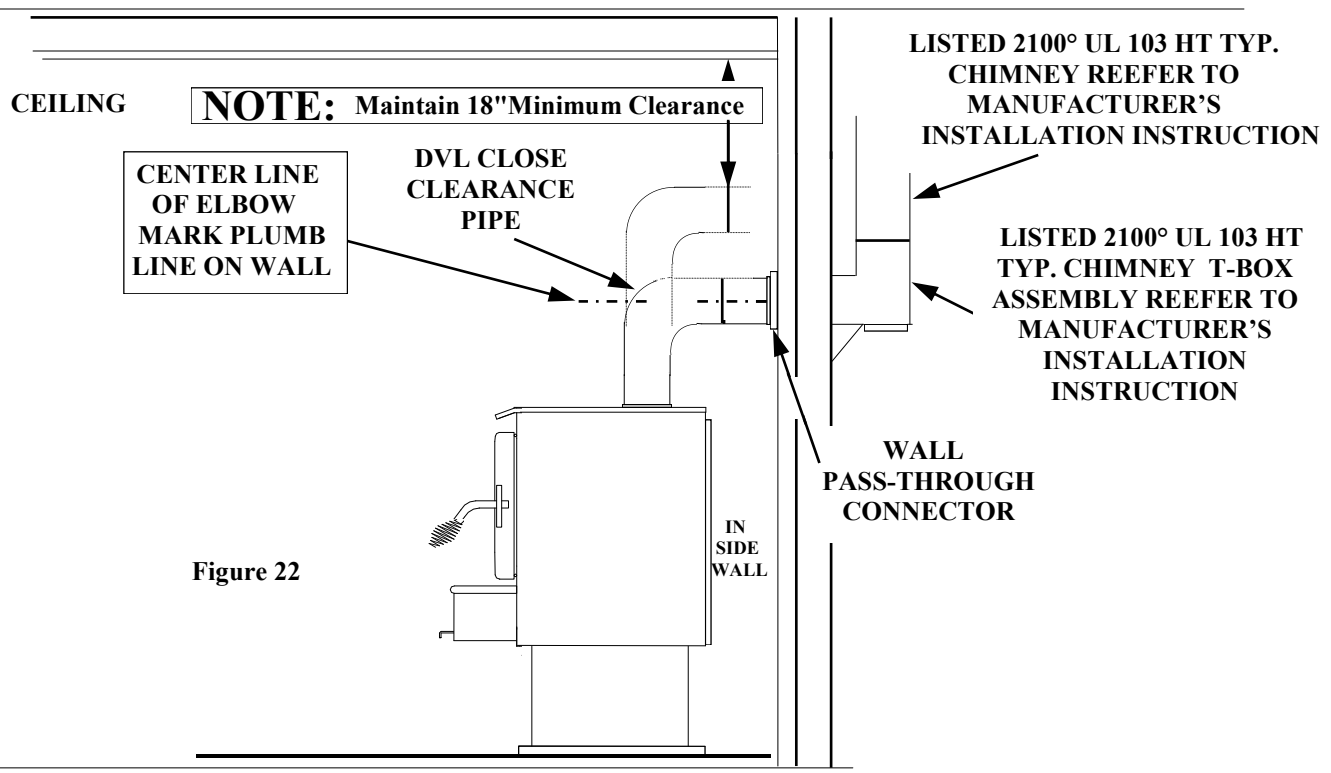

Figure 22

# HOW TO LOCATE CHIMNEY EXIT AND INSTALL

## Residential and Mobile Home Installation

### E. Vertical Exit using (6" DVL Close Clearance pipe and any Listed 2100° UL 103 HT chimney).

**With optional close clearance shield and pipe shield. NOTE: For installation of optional close clearance shields and pipe shield (See Page 35).**

NOTE: For minimum clearances see page 26, figure 23.

If pedestal kit is being used and outside air is required (See Pages 15-16).

1. Suspend a plumb bob from ceiling above unit so that weight is hanging in the center of flue exit. (A small weight on a string will serve as a plumb bob). Mark ceiling where string is suspended to locate center of chimney. (See Page 26, Figure 24).
2. After locating center of hole, install ceiling support box, chimney or chimney connector, flashing and rain cap, per chimney manufacturer's instructions and local building codes for installation through combustible walls or ceilings.
3. Now connect stove and ceiling support box using DVL close clearance pipe. Connect each section per manufacturer's instructions. Secure each section to each other using minimum (3) sheet metal screws or rivets. DVL close clearance is to be connected with (3) sheet metal screws or rivets to connector collar on heater (See Page 26, Figure 24).
4. NOTE: If your local code requires outside air for residential installation, refer to pages 15-16 for outside air installation.

**E. Vertical exit using (6" DVL Close Clearance pipe and any listed 2100° UL 103 HT. TYPE Chimney).  
With optional close clearance shield and pipe shield.  
Model 21 minimum clearance to combustibles.**

Figure 23

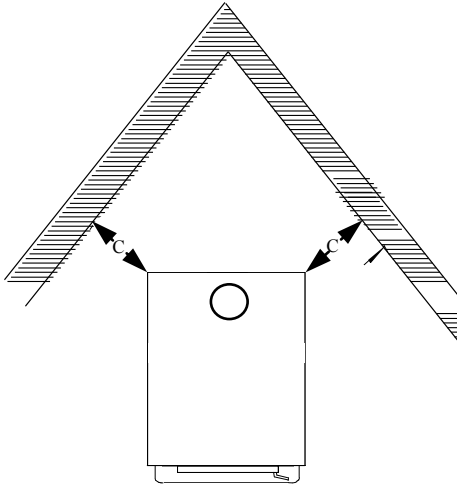
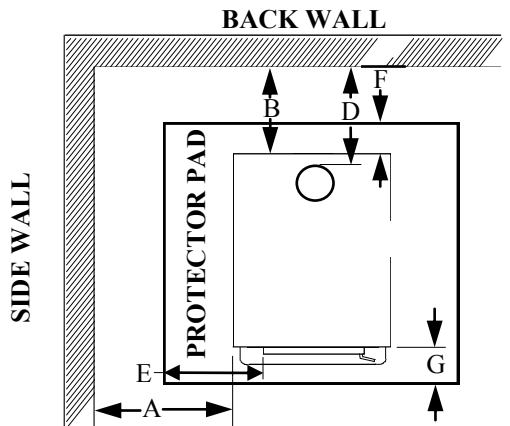

A B C D E F G

MODEL 21 19" 7" 7" 8.5" 8" 6" 16"

Figure 24

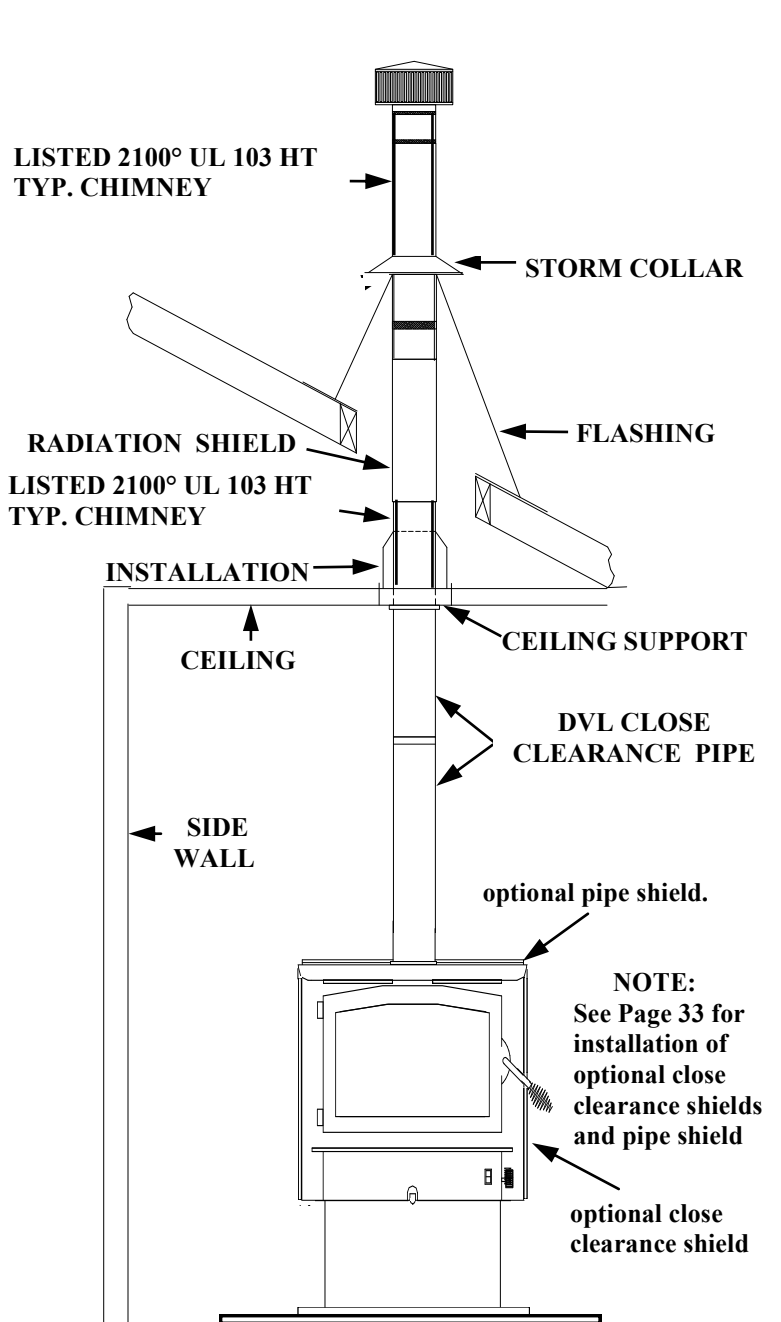

**NOTE:** All clearances are to combustibles with optional close clearance shields and pipe shield, using DVL Close Clearance pipe and minimum floor protector.

# HOW TO LOCATE CHIMNEY EXIT AND INSTALL

## Residential and Mobile Home Installation

- F. Vertical Wall Exit using (6" DVL Close Clearance Pipe and Elbow and any Listed 2100° UL HT chimney and Listed 2100° UL HT T-Box assembly).  
With optional close clearance shield and pipe shield NOTE: For installation of optional close clearance shields and pipe shield (See Page 35).**

NOTE: For minimum clearances (See Page 28, Figure 25).

If pedestal kit is being used and outside air is required (See Pages 15-16).

1. Mark plumb line on wall directly behind center of heater.  
(See Page 28, Figure 26).  
**NOTE:** When using DVL Close Clearance Pipe, maintain manufacturer's minimum clearances between pipe and ceiling.
2. Place vertical portion of heater pipe and elbow in position and project a point onto plumb line level with center of elbow.
3. Measure up so there will be at least 1/4" rise per foot of horizontal connector pipe, maintaining clearances to ceiling as noted in (Page 28, Figure 26). This will give you center of hole for chimney penetration.
4. After locating center of the penetration, install the tee-box and chimney, per chimney manufacturer's specifications.
5. Connect the DVL close clearance pipe to tee-box, per manufacturer's instructions. DVL close clearance pipe is to be connected with (3) sheet metal screws or rivets to connector collar on heater.(See Page 28, Figure 26).
6. NOTE: If your local code requires outside air for residential installation, refer to pages 15-16 for outside air installation.

**F. Vertical wall exit using (6" DVL Close Clearance pipe with elbow and any listed 2100° UL 103 HT. TYPE Chimney and Listed 2100° UL HT T-Box assembly).  
With optional close clearance shield and pipe shield.  
Model 21 minimum clearance to combustibles.**

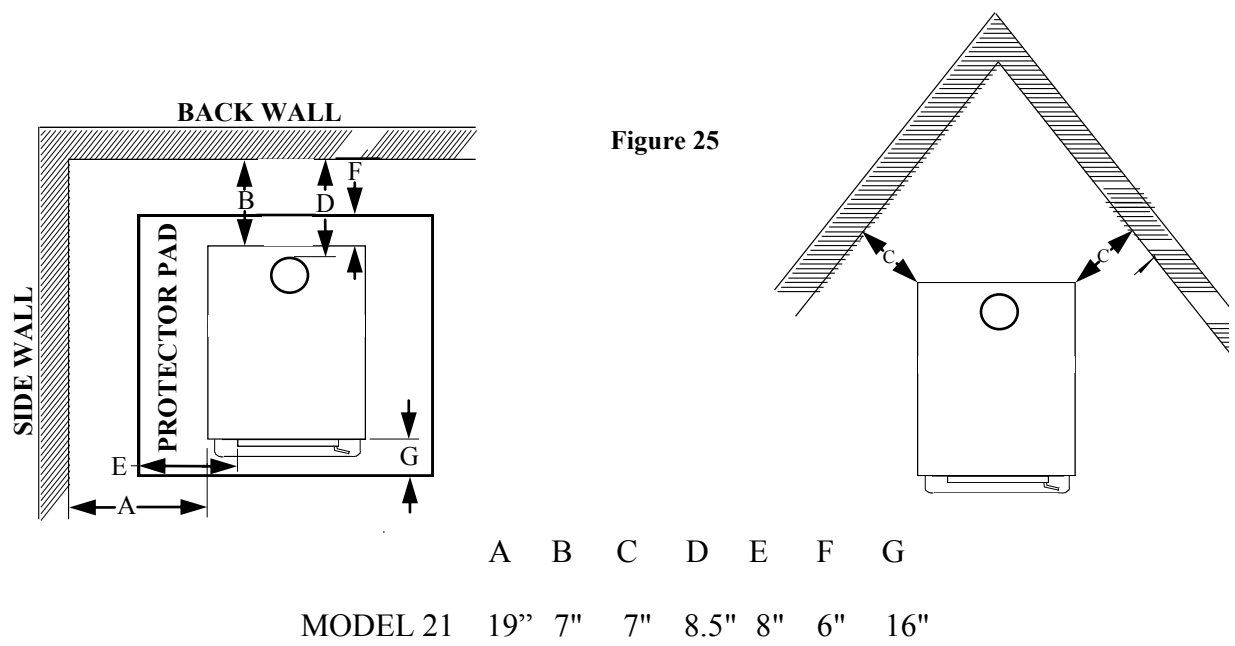

Figure 25

**NOTE:** All clearances are to combustibles with close clearance shields and pipe shield, DVL Close Clearance pipe with elbow and minimum floor protector.

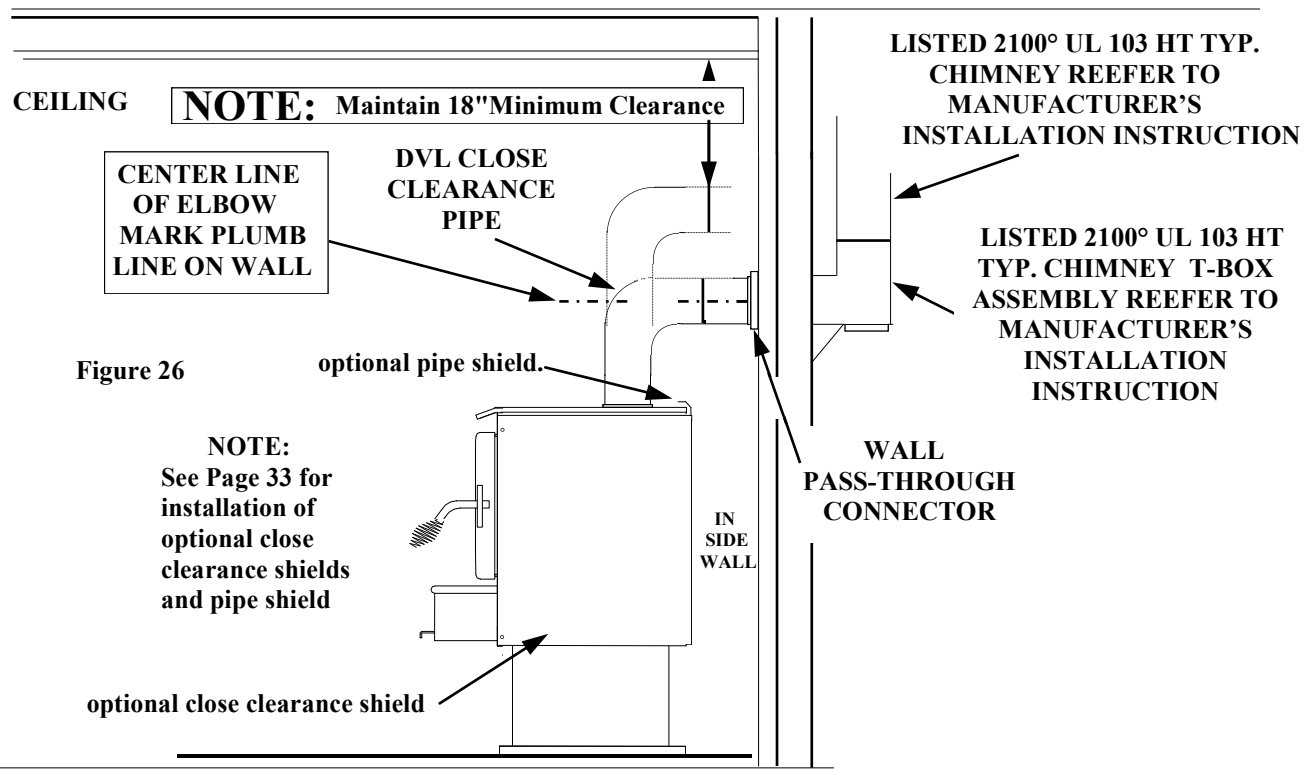

Figure 26

## Ceiling Exit (Using Close Clearance listed chimney)

1. Suspend a plumb bob from ceiling above unit so that weight is hanging in center of flue exit. (A small weight on a string will serve as a plumb bob). Mark ceiling where string is suspended to locate center of chimney hole.
2. After locating center of hole install ceiling support box, chimney flashing and rain cap. Only use 2100° UL 103 HT chimney and parts listed in this manual, per chimney manufacturer's instruction.

### CAUTION

**REFER TO CHIMNEY MANUFACTURER'S INSTRUCTIONS FOR ASSEMBLY AND DISASSEMBLY OF CHIMNEY PARTS. BE SURE TO FOLLOW CHIMNEY INSTRUCTIONS FOR PROPER CLEARANCES TO COMBUSTIBLE AND PROPER AIR SPACING REQUIRED.**

3. Add additional pipe until both of following are met:
  - (a) Chimney pipe is 3 feet higher than roof at point where it penetrates roof.
  - (b) Chimney pipe height is at least 2 feet higher than any part of roof within 10 feet of chimney.
 (See Figure 27).

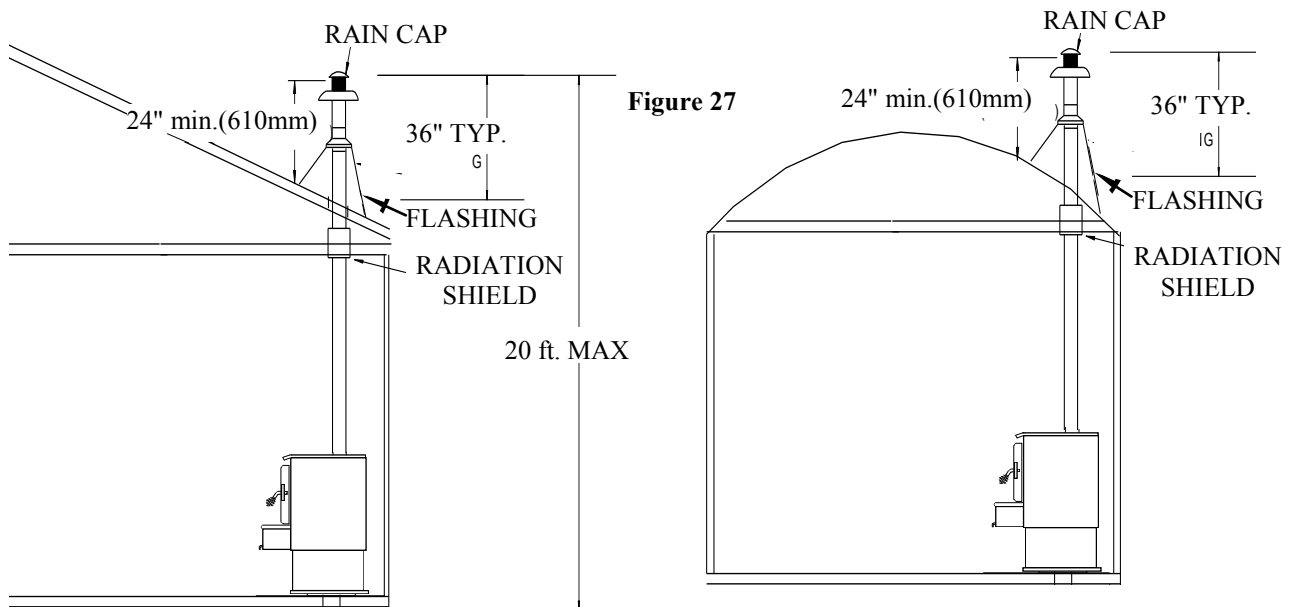

4. Using only double wall chimney connector listed in this manual (See Page 13), connect heater to chimney by following chimney manufacturer's installation instructions exactly. (See Figure 28).

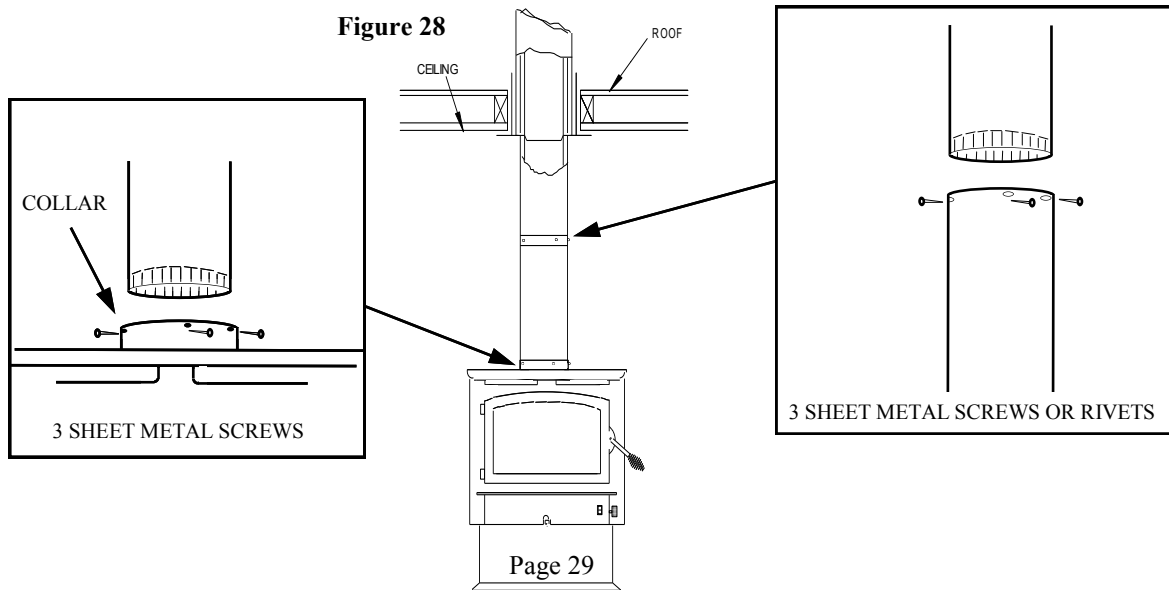



## FINAL CHECK

1. Recheck specified clearances.
2. Remove all foreign material from firebox area.
3. Open primary air draft.
4. Plug power cord into a 115V AC outlet when using with optional motor. Do not run cord under unit or in high traffic areas.
5. Place crumpled pieces of newspaper in the stove. Light it and close the door. Ensure that stove draws properly through primary draft.
6. Check for smoke leaks around the door.

### CAUTION

**Open the door and check for smoke escaping from the front of stove. Smoking usually indicates a defective or poorly positioned chimney. Some chimneys with a marginal draft can be preheated by lighting newspaper and holding it near open damper with a poker or fire tong. Once the chimney heats up, a proper draft can usually be obtained.**

If a thorough review of the Troubleshooting Guide in the manual does not reveal problem, contact your dealer for assistance.

### CAUTION

**The unit is painted with a specially formulated high temperature paint that cures during the first two or three firings. You may notice a slight smoking effect and an odor of burning paint when you build the first fires. This is normal and is not a cause for alarm. In some cases, these fumes will activate a smoke alarm. Opening a window near the unit will allow these fumes to escape. DO NOT build a large, roaring fire until this curing is complete or heater finish may be damaged.**

# SECTION V

## ALCOVE INSTALLATION AND CLEARANCES

Select an installation location that will give the best airflow from the front of the heater to the remainder of the home

### PREPARING THE STOVE FOR INSTALLATION

1. Inspect the unit for any obvious physical damage.
2. Plug the power cord into a 115V AC outlet to test the motor and fan when optional motor is being used. Do not run power cord under unit or in high traffic areas.
3. Check the primary air draft control to ensure that it slides freely.(See Figure 29).
4. Remove any items from within firebox. Spread a dropcloth on door behind heater. Next, tilt heater so that back is on the drop cloth.
5. If leg kit is to be used follow steps 1-6.
6. Then obtain four legs, attach legs to holes in bottom of unit with bolts and washers supplied with the leg kit. (See Figure 29).
7. Open freestanding kit and obtain stand. Place stand against bottom of heater (angle side to heater).Center stand front to rear and also center stand left and right. Mark screw locations on bottom of the stove through outer holes of stand mounting angles. Set stand aside and drill four 7/32" holes in heater bottom.Then mount stand to bottom of heater with screws provided. (See Figure 30).
8. Obtain four (4) 3/16" self-tapping screws and secure the stand to the heater.
9. Reposition the heater to the upright position.

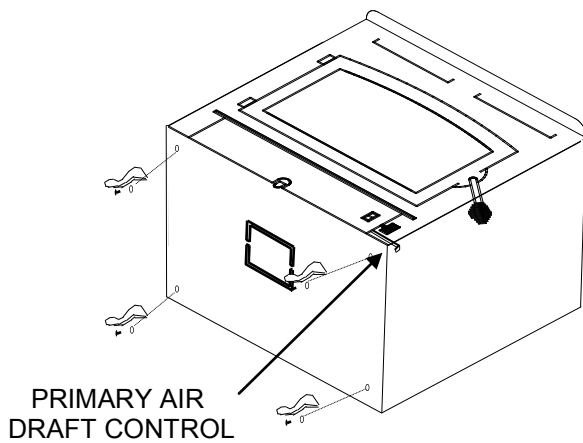

Figure 29

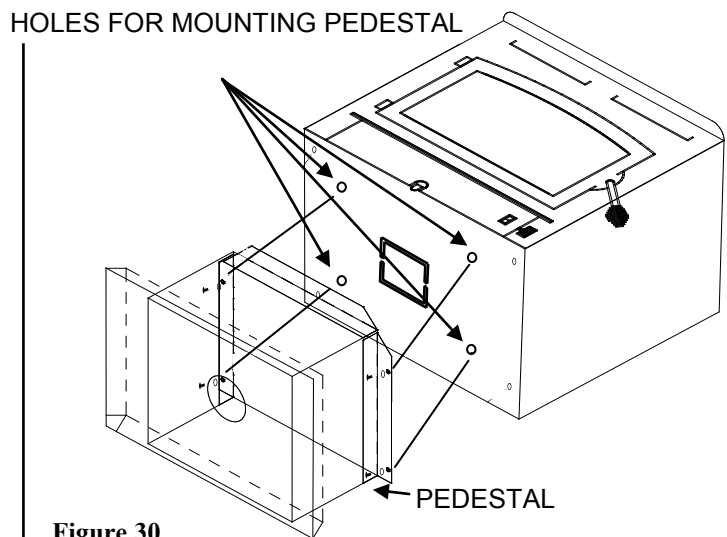

Figure 30

## Chimney

This model is designed for connection to any listed 2100° UL103 HT chimneys and parts. Follow chimneys manufacturer's instructions carefully.

This room heater must be converted to (1) a chimney complying with the requirements for Type HT chimneys in the Standard for chimneys, Factory-Built, Residential, Type and Building Heating Appliance, UL 103, or (2) a code approved masonry chimney with a flue liner.

## Floor Protection:

Floor protection must be 3/8” minimum thickness non-combustible material or equivalent.

### How to use alternate materials and how to calculate equivalent thickness

An easy means of determining if a proposed alternate floor protector meets requirements listed in the appliance manual is to follow this procedure:

1. Convert specification to R-value:
  - R-value is given—no conversion is needed.
  - K-factor is given with a required thickness (T) in inches:  
C-factor is given:  $R=1/C$
2. Determine the R-value of the proposed alternate floor protector.
  - Use the formula in step (1) to convert values not expressed as “R”
  - For multiple layers, add R-values of each layer to determine the overall R-value.
3. If the overall R-value of the system is greater than the R-value of the specified floor protector, the alternate is acceptable.

#### Example:

The specified floor protector should be 3/4” thick material with a K-factor of 0.84.

The proposed alternate is 4” brick with a C-factor of 1.25 over 1/8” mineral board with a K-factor of 0.29.

Step (a): Use formula above to convert specification to R-value.  $R= 1/K \times T = 1/0.84 \times .75 = 0.893$

Step (b): Calculate R of proposed system. 4” brick of  $C=1.25$ , therefore  $R_{brick} = 1/C = 1/1.25 = 0.80$  1/8” mineral board of  $K = 0.29$ , therefore  $R_{min.bd.} = 1/0.29 \times 0.125 = 0.431$

Step (c): Compare proposed system R of 1.231 to specified R of 0.893. Since proposed system R is greater than required, the system is acceptable.

Definitions:

$$\text{Thermal conductance} = C = \frac{\text{Btu}}{(\text{hr})(\text{ft}^2)(\text{°F})} = \frac{W}{(\text{m}^2)(\text{°K})}$$

$$\text{Thermal conductance} = K = \frac{(\text{Btu})(\text{inch})}{(\text{hr})(\text{ft}^2)(\text{°F})} = \frac{W}{(\text{m})(\text{°K})} = \frac{(\text{Btu})}{(\text{hr})(\text{ft})(\text{°F})}$$

$$\text{Thermal conductance} = R = \frac{(\text{ft}^2)(\text{hr})(\text{°F})}{\text{Btu}} = \frac{(\text{m}^2)(\text{°K})}{W}$$

Install in accordance with 24 CFR, Part 3280 (HUD).

# HOW TO LOCATE CHIMNEY EXIT AND INSTALL

## Alcove Installation

**Vertical Exit using (6" DVL Close Clearance pipe and any Listed 2100° UL 103 HT chimney).**

**With optional close clearance shield and pipe shield. NOTE: For installation of optional close clearance shields and pipe shield (See Page 35).**

NOTE: For minimum clearances (See Page 34, Figure 31).

1. Suspend a plumb bob from ceiling above unit so that weight is hanging in the center of flue exit. (A small weight on a string will serve as a plumb bob). Mark ceiling where string is suspended to locate the center of the chimney.
2. After locating center of hole, install the ceiling support box, chimney or chimney connector, flashing and rain cap, per chimney manufacturer's instructions and local building codes for installation through combustible walls or ceilings.
3. Now connect stove and ceiling support box using DVL close clearance pipe. Connect each section per manufacturer's instructions. Secure each section to each other using minimum (3) sheet metal screws or rivets. DVL close clearance is to be connected with (3) sheet metal screws or rivets to connector collar on heater.(See Page 34,Figure 32).
4. NOTE: If your local code requires outside air for residential installation, refer to pages 15-16 for outside air installation.

# ALCOVE INSTALLATION AND CLEARANCES

**Vertical exit using (6" DVL Close Clearance pipe and any listed 2100° UL 103 HT. TYPE Chimney).  
With optional close clearance shield and pipe shield.  
Model 21 minimum clearance to combustibles.**

Figure 31

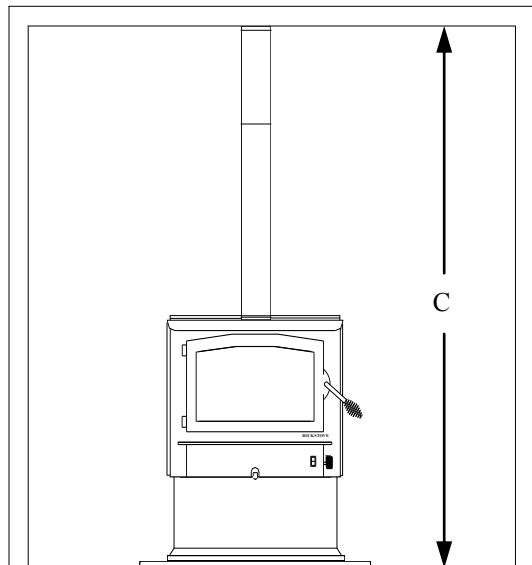
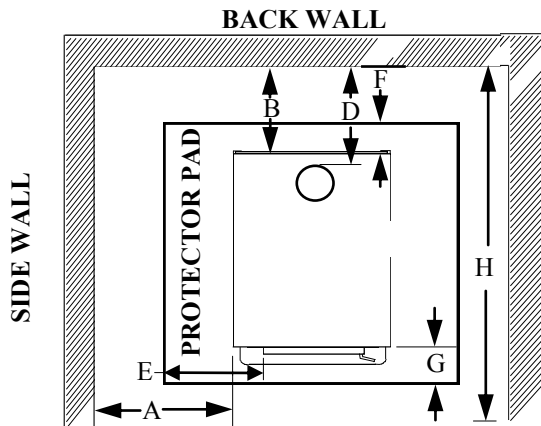

A   B   C   D   E   F   G   H

MODEL 21   19"   7"   84"   8.5"   8"   6"   16"   48"

Figure 32

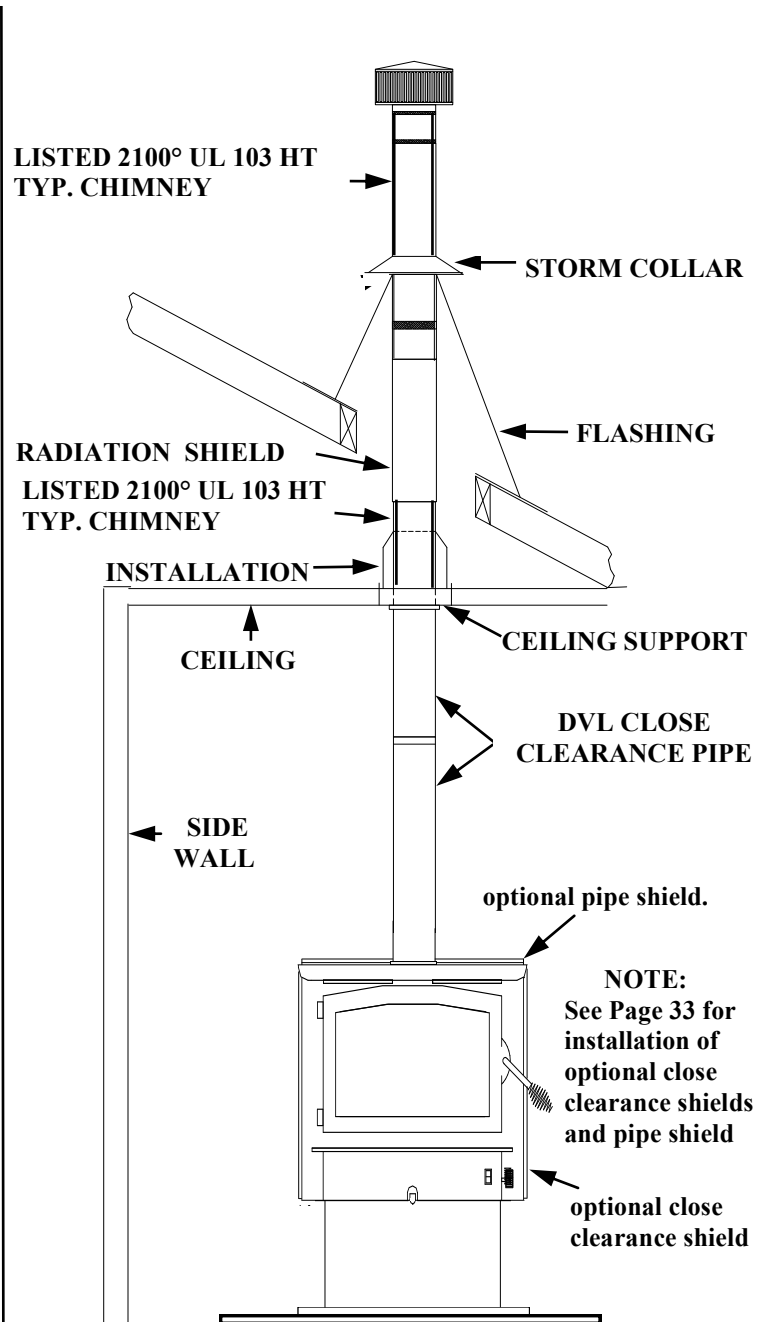

**NOTE:** All clearances are to combustibles with optional close clearance shields and pipe shield, using DVL Close Clearance pipe and minimum floor protector.

## Installation of (Optional) Close Clearance Shields and Pipe Shield

1. Taking close clearance side shields, hold up to side of stove leaving 1/4" gap between shield and top of stove.
2. Make reference mark in center of pre-punched hole in top & bottom rear of shield. Drill two (2) 3/32" holes in back of unit each side. Install shield using two(2) 10-16 x 3/4" Tek. self drilling screws in through shield into stove back for each side shield. (SEE PICTURE BELOW)
3. Drill two(2) 3/16" holes in the sides of stove where shield meets front side. Install side of shields using two(2) 1/4-14 X 3/4" Tek. self drilling screws (TWO per front side). (SEE PICTURE BELOW)
4. Next loosen two (2) top screws holding side shield at rear top. Insert pipe shield where back shield and top rear side shield meets. Leave a 1" gap from the top of stove to the pipe shield, tighten screws.(SEE PICTURE BELOW)

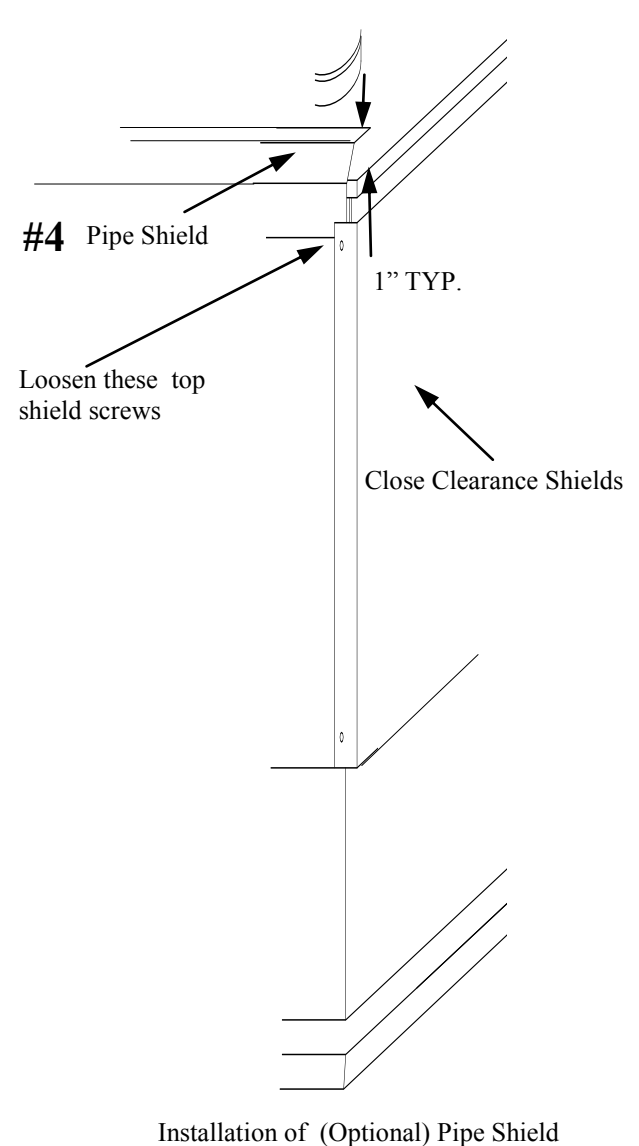
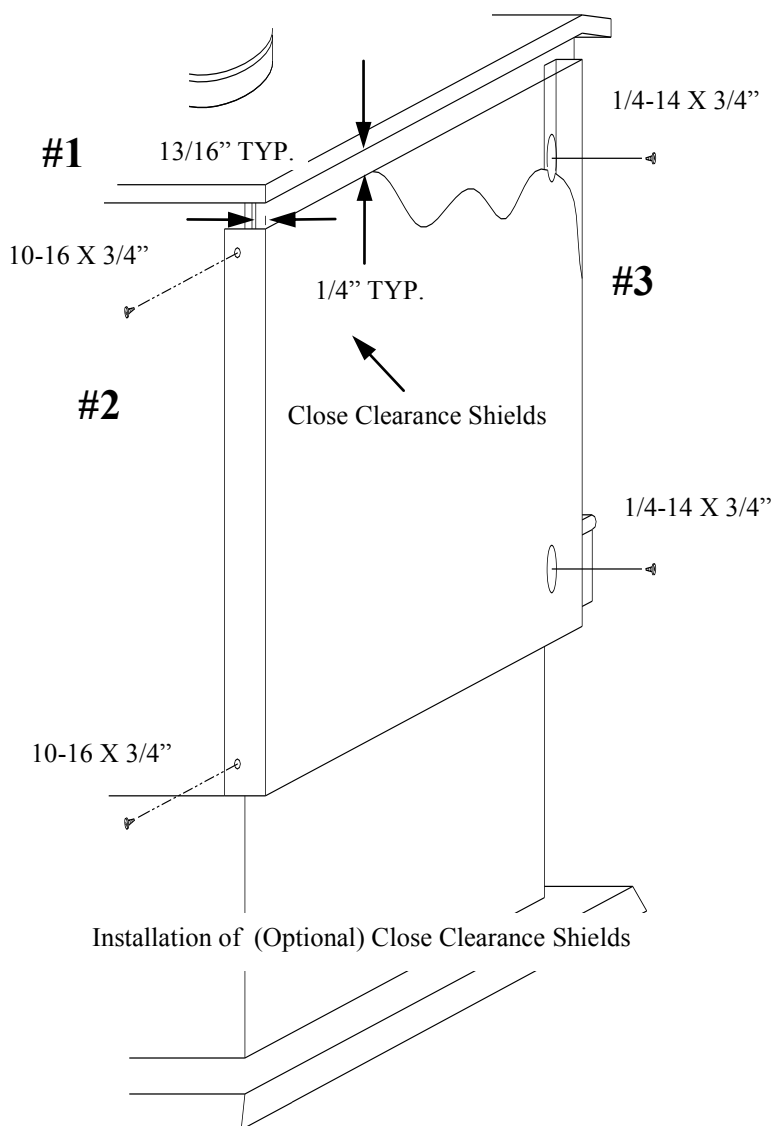

## FINAL CHECK

1. Recheck specified clearances.
2. Remove all foreign material from firebox area.
3. Open primary air draft.
4. Plug power cord into a 115V AC outlet when using with optional motor. Do not run cord under unit or in high traffic areas.
5. Place crumpled pieces of newspaper in the stove. Light it and close the door. Ensure that stove draws properly through the primary draft.
6. Check for smoke leaks around the door.

### CAUTION

**Open door and check for smoke escaping from front of stove. Smoking usually indicates a defective or poorly positioned chimney. Some chimneys with a marginal draft can be preheated by lighting newspaper and holding it near the open damper with a poker or fire tong. Once the chimney heats up, a proper draft can usually be obtained.**

If a thorough review of the Troubleshooting Guide in the manual does not reveal the problem, contact your dealer for assistance.

### CAUTION

**The unit is painted with a specially formulated high temperature paint that cures during the first two or three firings. You may notice a slight smoking effect and an odor of burning paint when you build the first fires. This is normal and is not a cause for alarm. In some cases, these fumes will activate a smoke alarm. Opening a window near the unit will allow these fumes to escape. DO NOT build a large, roaring fire until this curing is complete or the heater finish may be damaged.**

## SECTION VIII

# WOOD HEATER SAFETY

Certain safety hazards are inherent in any wood heater installation. You should be aware of these so that a safe and proper installation can be made.

1. **FAULTY CHIMNEY:** An older masonry chimney should be thoroughly checked to be sure there are no holes or weak spots which could allow sparks or hot gases to escape.
2. **HEAT CONDUCTION:** Placing combustible materials too close to a heater or chimney can be a fire hazard.

By keeping these particular hazards in mind as you install and use your room heater you can ensure a safe, reliable installation.

The chimney and chimney connector should be inspected once every two months. Any build-up of soot should be removed to prevent risk of a chimney fire. To remove chimney or chimney connector, remove screws or fasteners then remove pipe and clean with steel brush. Replace chimney or chimney connector. Replace screws and/or fasteners.

### CAUTION

**NEVER USE GASOLINE, GASOLINE TYPE LANTERN FUEL, KEROSENE, CHARCOAL LIGHTER FLUID OR SIMILAR LIQUIDS TO START OR "FRESHEN UP" A FIRE IN THE HEATER. KEEP ALL SUCH LIQUIDS WELL AWAY FROM STOVE WHEN IT IS IN USE. ALL FLUIDS OF THIS TYPE GIVE OFF VOLATILE FUMES AND CAN AND WILL EXPLODE! DON'T TAKE A CHANCE WITH SAFETY OF YOUR HOME AND FAMILY.**

**CAUTION:** Never remove ashes from heater with blower running.

**DISPOSAL OF ASHES:** Ashes should be placed in a metal container with a tight fitting lid. The closed container of ashes should be placed on a noncombustible floor or on the ground, well away from all combustible materials pending final disposal. If ashes are disposed of by burial in soil or otherwise locally dispersed, they should be retained in closed container until all cinders have thoroughly cooled.

**CREOSOTE—FORMATION AND NEED FOR REMOVAL:** When wood is burned slowly, it produces tar and other organic vapors, which combine with expelled moisture to form creosote. The creosote vapors condense in the relatively cool chimney flue of a slow-burning fire. As a result, creosote residue accumulates on flue lining. When ignited this creosote makes an extremely hot fire.



## SECTION VI OPERATION/EFFICIENCY

1. "To maximize the efficiency of your wood stove make sure it is sized properly for the space you plan to heat. An oversized stove will burn and be forced to burn at a lower and dirtier burn rate. Consult with your dealer for sizing your stove correctly.
2. Use dry, seasoned wood only. Recommended fire wood length 10" front to back. Using wet wood will greatly reduce your efficiency.
3. Consult with your installer/dealer to correctly place the stove in your home. An incorrectly placed stove can greatly reduce efficiency.

Maximizing the efficiency of your stove will heat your house quickly, burn cleaner and use less wood.

**Use dried split wood (6-12 months) and placed from front to back position in heater.** (See Page 5 Bottom Picture).

"This wood heater has a manufacturer-set minimum low burn rate that must not be altered. It is against federal regulations to alter this setting or otherwise operate this wood heater in a manner inconsistent with operating instruction in this manual."

**NOTE:** "Following all suggested operating and maintenance procedures will help minimize visual emissions.

The following steps will serve as a guide for operating your stove.

### BUILDING A FIRE

1. Open door.
2. Open primary air control. Primary air intake draft control is located at center bottom side of hearth. It is operated by moving handle **IN** to open (to allow air into firebox) or **OUT** to control or close off the firebox. (Figure 35 primary air control).

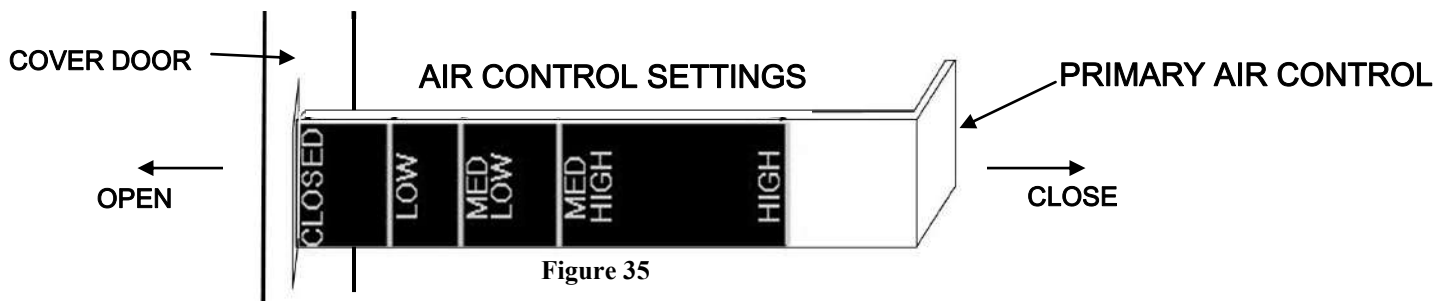

1. Twist two pieces of non-colored newspaper into a roll and place them on floor of firebox.  
**NOTE: Do not use grate or elevate fire. Build wood fire directly on inner bottom of fire box.**
2. This model is not designed for use of grates, andirons or other methods of supporting fuel.
3. Lay several pieces of dry kindling on top of newspaper.
4. Place three or four small pieces of firewood, 2"-3" in diameter, on top of kindling.
5. Light newspaper in front. Close and latch door. Don't leave fire unattended at this point. The draft system of heater should start quickly. It may be necessary to preheat chimney to get draft started. To do this, open door and add newspaper to top rear of wood. Light or let this paper ignite and allow to burn while holding the door slightly cracked. Once draft has started, close and lock door. You are over-heating the unit if the chimney and or connector glows red.
6. **NOTE: After embers and a coal bed have been established, load heater with seasoned natural hard wood, placing it front to rear.**

**NOTE: THE FUELING DOOR MUST REMAIN CLOSED DURING OPERATION.**

Your stove is equipped with an automatic thermostat. When stove gets hot enough, thermostat will activate room air blower. Set fan speed on low, when burning on low, med-low or med-high. Set fan speed on high when burning on high.

**NOTE: When refueling or removing ashes turn "OFF" room air blower. Be sure to turn room air blower back on when finished.**

**NOTE: Do not run power cord underneath heater or in walk way or heavy traffic areas.**

## GUIDE TO THE DIFFERENT BURNING QUALITIES OF WOOD

<b>Type of Wood</b>	<b>Ease of Starting</b>	<b>Coaling Qualities</b>	<b>Amount of Sparks</b>
Apple	Poor	Excellent	Few
Ash	Fair	Good	Few
Beech	Poor	Good	Few
Birch	Good	Excellent	Moderate
Cherry	Poor	Excellent	Few
Cedar	Excellent	Poor	Many
Elm	Fair	Good	Very Few
Hemlock	Good	Low	Many
Hickory	Fair	Excellent	Moderate
Locust	Poor	Excellent	Very Few
Maple	Poor	Excellent	Few
Oak	Poor	Excellent	Few
Pine	Excellent	Poor	Moderate

The Maine Audubon Society recently charted the heat produced by a wood fire. They noted that heat produced by a wood fire varies greatly with kind of wood burned. Beech is considered best wood for a fire. A cord of well-seasoned Beech will produce as much heat as 169 gallons of fuel oil; Sugar Maple and Red Oak produce as much heat as 166 gallons of fuel oil; followed by White Ash 154; American Elm 130; White Birch 124; and White Pine 94.

# HOW TO REPLACE MOTOR, THERMOSTAT, & RHEOSTAT INSTALLATION INSTRUCTIONS

STEP 1: REMOVE ACCESS DOOR PANEL LOCATED AT BOTTOM OF UNIT. REMOVE THE 2 SCREWS AIR CONTROL BRACKET & ROD USING A 3/8" DRIVER WITH DRILL. THIS METHOD IS ONLY RECOMMENDED WHEN STOVE IS INSERTED IN FIREPLACE. YOUR MOTOR ASSEMBLY COMES WITH A BRACKET ALREADY ATTACHED TO THE MOTOR. ALIGN THE HOLES IN MOTOR BRACKET WITH HOLES IN MOTOR MOUNT. SECURE BRACKET WITH TWO 1/2" HEX HEAD SCREWS PROVIDED.

STEP 2: REMOVE THE PROTECTIVE BACKING OFF THE RHEOSTAT INDICATING LABEL AND PLACE THE HOLE IN CENTER OF LABEL TO LINE UP WITH HOLE IN THE RIGHT SIDE HEARTH SUPPORT AS YOU FACE THE UNIT. PLACE LABEL SO "OFF" POSITION IS AT THE 8 O'CLOCK POSITION AND "LOW" IS AT 4 O'CLOCK POSITION. MOUNT RHEOSTAT BY PLACING IT BEHIND HEARTH SUPPORT WITH WIRES ON BOTTOM SIDE. PLACE PLASTIC STUD SUPPORT WITH WIRES ON BOTTOM SIDE. PLACE PLASTIC STUD THROUGH HOLE IN BRACKET AND SECURE WITH RHEOSTAT MOUNTING NUT. PLACE INDICATOR KNOB ON PLASTIC STUD.

STEP 3: REMOVE STRAIN RELIEF COVER FROM HEARTH SUPPORT AND DISCARD. MOUNT POWER CORD STRAIN RELIEF HOLDER IN COVER MOUNTING HOLES. PLACE THERMOSTAT BEHIND "C" CLIP LOCATED UNDER HEARTH TO THE RIGHT OF MOTOR. USE CABLE TIE TO SECURE LOOSE WIRES.

STEP 4: REINSTALL THE ROD AND BRACKET, MAKE SURE YOU PLACE THE ROD IN THE HOLDER THAT IS TOWARDS THE BACK OF THE STOVE. REINSTALL ACCESS DOOR PANEL.

STEP 5: PLUG POWER CORD INTO SUPPLY OUTLET. PLACE RHEOSTAT INDICATING KNOB IN POSITION DESIRED. WHEN HEATER REACHES TEMPERATURE, FAN WILL OPERATE AT DESIRED SPEED.

IT WILL BE NECESSARY TO OCCASIONALLY CLEAN FAN BLADES FOR MAXIMUM PERFORMANCE. DUST AND DIRT BUILDUP ON FAN BLADES WILL SHORTEN MOTOR LIFE AND RESTRICT AIR FLOW WHICH COULD DAMAGE MOTOR.

NOTE: ROUTE POWER CORD TO PREVENT DAMAGE TO CORD INSULATION FROM HEAT AND SHARP OBJECTS. KEEP CORD OUT OF THE WAY OF TRAFFIC TO PREVENT DAMAGE CAUSED BY TRIPPING, ECT.

# MOTOR -THERMOSTAT-RHEOSTAT REPLACEMENT

To replace Motor, Thermostat, Rheostat follow steps below.

## STEP 1

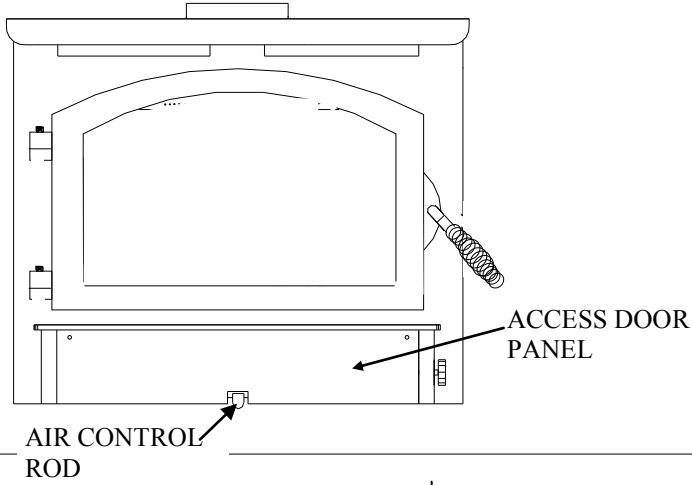

## STEP 2

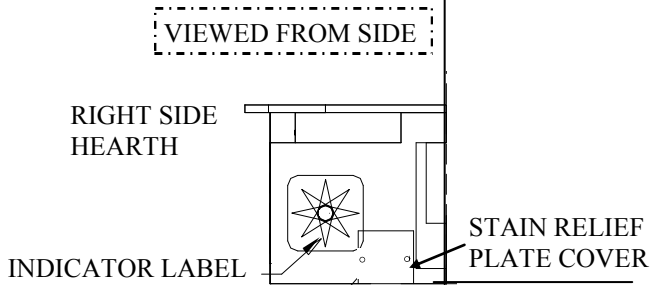

## STEP 3

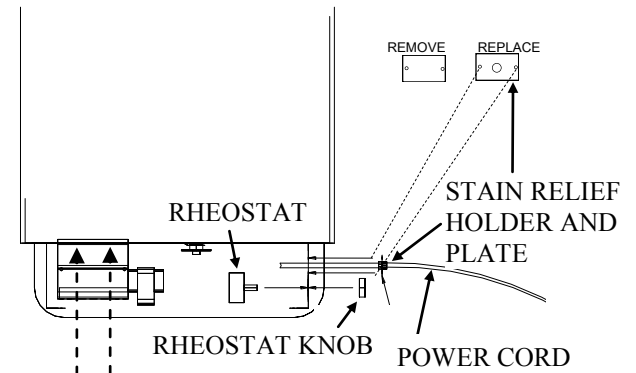
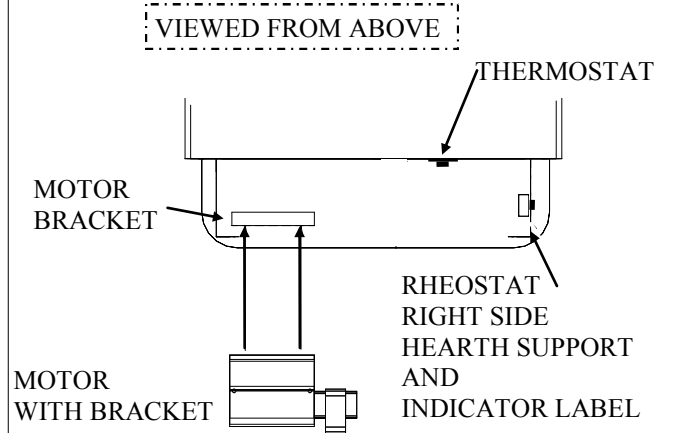

## WIRE DIAGRAM

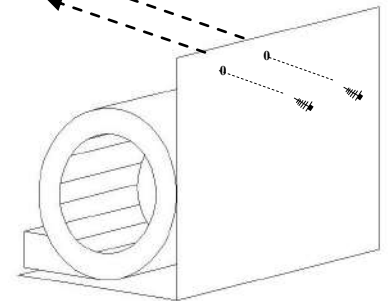
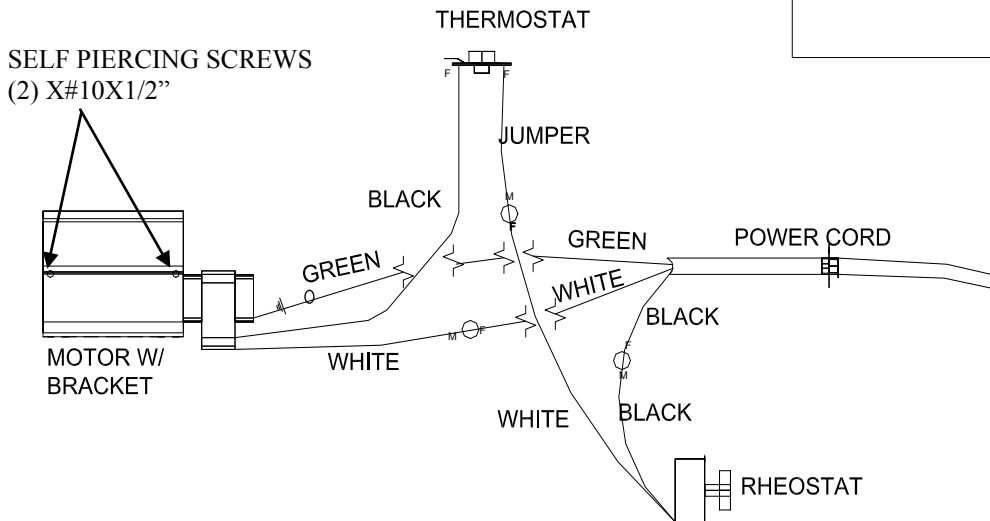

SELF PIERCING SCREWS  
(2) X#10X1/2"

## ASSEMBLY PARTS

- 1 - MOTOR (NON-CAT)
- 1 - MOTOR BRACKET
- 6 - #10 - 16 X 1/2" HEX HEAD
- 1 - #6 - 32 X 1/2" SLOT HEAD SCREW
- 5 - 1/8" X 1" BLACK FLAT GASKET WITH ADHESIVE
- 1 - JUMPER WIRE 4" MALE & FEMALE TERMINAL
- 1 - 110 THERMOSTAT
- 1 - RHEOSTAT
- 1 - RHEOSTAT NUT
- 1 - RHEOSTAT INDICATOR KNOB
- 1 - RHEOSTAT LABEL
- 1 - POWER CORD
- 1 - STRAIN RELIEF
- 1 - 6" WIRE TIE
- 1 - STRAIN RELIEF HOLDER (METAL)
- 1 - WIRE TIE FOR POWER CORD
- 1 - INSTRUCTIONS

# SECTION VII MAINTENANCE

## BRICK LAYOUT

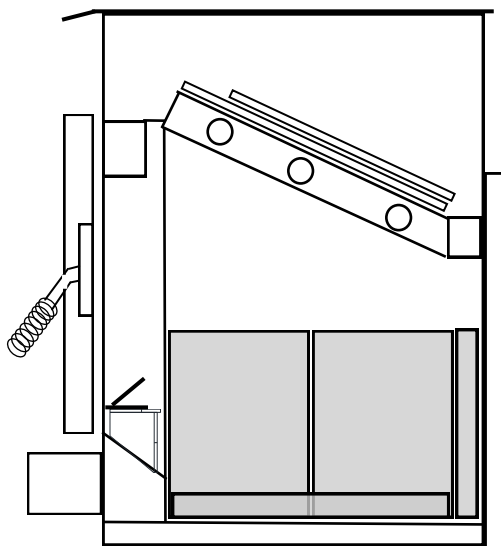
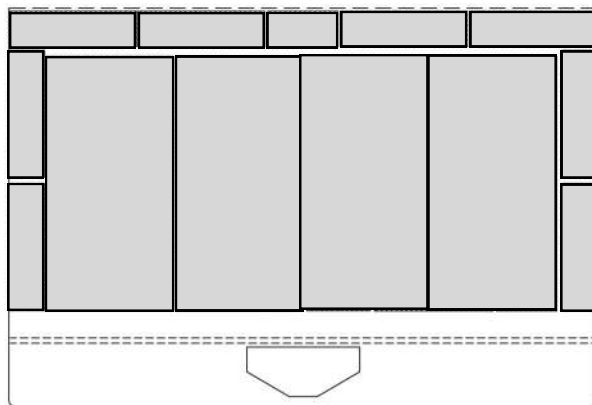

NOTE: “This wood heater needs periodic inspection and repair for proper operation. It is against federal regulations to operate this wood heater in a manner inconsistent with operating instructions in this manual.”

# MAINTENANCE

## SECONDARY AIR TUBES REPLACEMENT

(Replacing secondary air tubes)  
COLD STOVE

1. Unplug heater from 115V AC outlet.
2. Put drop cloth down.
3. Empty ashes.
4. Remove air tubes. The (3) secondary air tubes are located in top of burn chamber. (NOTE, front/rear air tubes have 24 holes per tube, middle air tube has 12 holes per tube) On right side of tubes you will find a cotter pin. To remove air tube remove cotter pin and slide tube to left, it will drop down, slide tube to right it should come out. (See Figure Below).
5. Replace air tube. On one end of tube you will find a hole drilled on both sides through the tube. This end goes to right side. Place tube in left tube holder and slide other end of tube into right side tube holder. Line up through hole in air tube with tube holder bracket and replace cotter pin and bend slightly so it wont fall out.

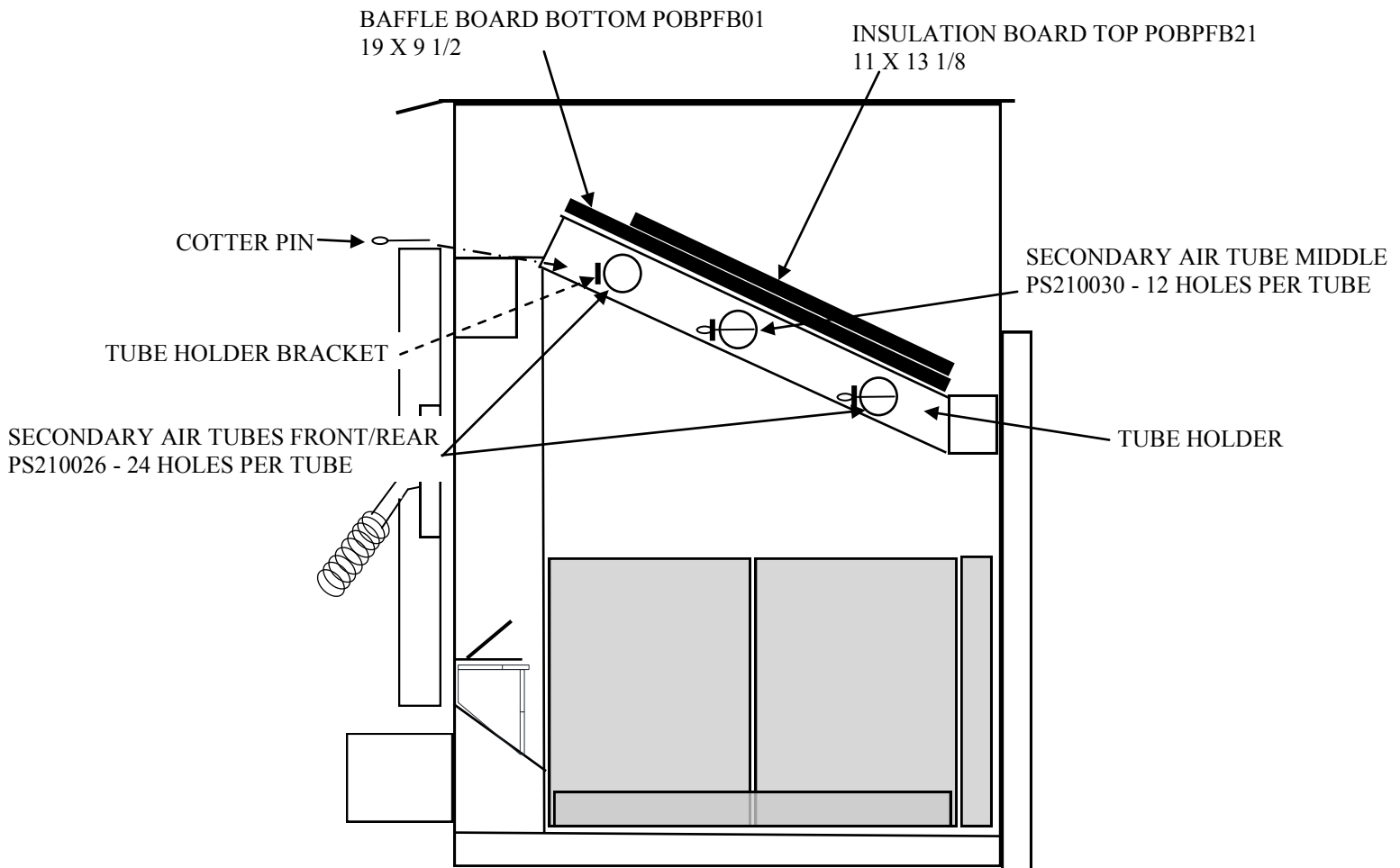

Figure 32

## BAFFLE BOARDS REPLACEMENT

(Replacing baffle board)  
COLD STOVE

1. Unplug heater from 115V AC outlet.
2. Put drop cloth down and empty ashes.
3. Repeat steps 1-5 from above removing 1st tube only.
4. The baffle boards run long ways front to rear. Lift and slide baffle board toward the front. (See Figure Above).
5. Replace baffle board making sure the board is seated on top of air tubes and behind front baffle board holder. After replacing both baffle boards replace front air tube following step 5 from secondary air tube replacement.

# DOOR GASKET REPLACEMENT (COLD HEATER)

To replace deteriorated gaskets, following steps must be taken to ensure proper installation of gaskets.

1. Obtain proper gaskets and silicone glue from your local dealer.
2. Using pliers, remove any worn and deteriorated gaskets.
3. Using a scraper, wire brush and sandpaper or steel wool, clean glue and gasket residue from door frame.
4. Measure and cut gaskets to length. Care should be taken not to stretch gaskets. What you want is a full and loose gasket weave after attachment to framing.
5. Obtain silicone glue and run a 3/16" bead inside door frame.
6. Obtain gasket (s) and place in gasket channel areas starting at lower right corner, see below. Use a technique which assures that gasket is applied in a loose like manner. **DO NOT STRETCH GASKETS.**
7. After gasket (s) are applied to glue, use your finger and go over all gasket gently pressing gasket to the channel. Use same pressure against gasket so that final result is an evenly applied gasket.
8. Leave door open and allow at least two (2) hours for glue to dry.
9. Once gaskets are checked, heater is ready for use.
10. This should be done annually. Allowing gaskets to deteriorate can cause over-firing and shorten burn time.

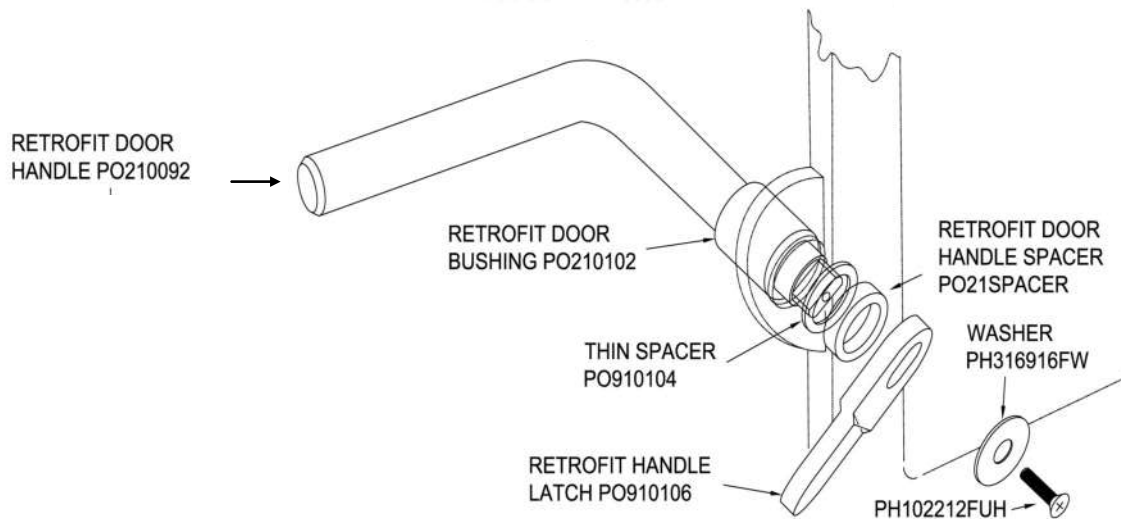
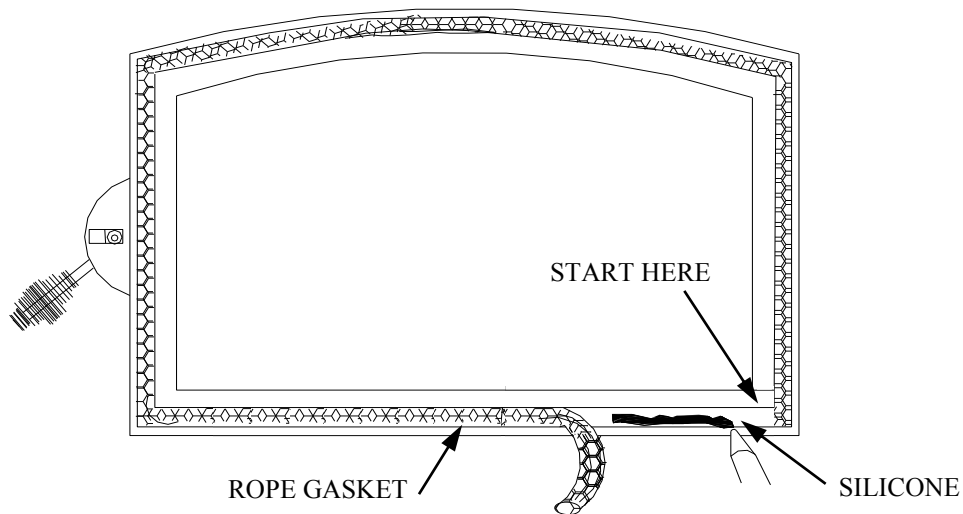



## CHECK CHIMNEY

- A. Chimney should be inspected twice a year.
- B. The chimney should be cleaned as necessary to remove creosote, soot, leaves, birds' nests, etc.

**⚠ NOTE:** A chimney cap should be installed to prevent moisture from entering chimney, to prevent sparks and burning materials from escaping chimney and to keep birds and foreign materials from entering.

**\* NOTE:** Some areas may require an approved spark arrestor.

Before sweeping the chimney a few steps must be done. Put drop cloth down.

1. Open feed door and remove the Front Secondary Air Tube by removing cotter pin up in right side facing stove. Remove Air Tube and cotter pin, set aside.
2. Remove the two Baffle Board's and set aside.
3. Close feed door for cleaning chimney so debris don't fall out feed door while cleaning chimney.
4. Creosote and debris will fall into the bottom of the stove unit from the cleaning.
5. Clean out all the creosote and debris from inside stove unit, if any is left from clean sweeping chimney.
6. Replace Baffle Board's and Front Secondary Air Tube reverse steps 1-3

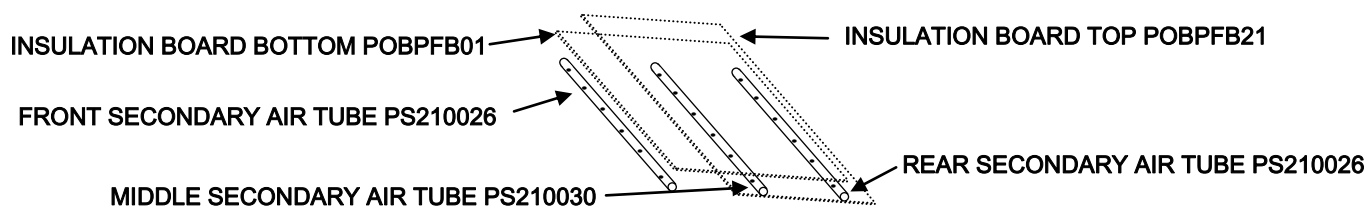

## CLEANING THE HEATER

- A. The heater should not be cleaned with any type of detergent as most all detergents have an oil base and cannot be painted over.
- B. The heater should be lightly sanded with fine sandpaper or steel wool, then repainted or touched up with high temperature paint.
- C. If the heater is located in a moist or damp location, check thoroughly for signs of condensation during times when heater is not in use.
- D. When heating season is over, heater should be cleaned out completely with a wire brush or cloth to help eliminate ash and burned wood smell.

## CARE OF GLASS DOOR

The glass door on your heater permits you to enjoy the beauty of the fire while retaining efficiency of your heater. Although brand of glass used in heater door has well established and recognized heat resistant and strength characteristics, it can be broken through improper care. To achieve maximum utility and safety of your glass door, we advise that you observe following use and safety tips:

1. Inspect glass regularly for cracks or breaks. If you detect a crack or break extinguish fire immediately and return door to your dealer for glass replacement before further use.
2. Do not slam heater door or otherwise impact glass. When closing door, make sure that no logs or other objects protrude or impact against glass.
3. Do not clean glass with materials which may scratch it (such as steel wool) or otherwise damage glass. Scratches on the glass can develop into cracks or breaks.

The glass can be cleaned with a commercial oven cleaner, providing it does not contain abrasives. A build-up on glass that has been there for a considerable length of time can be burned off with a propane torch or straight razor blade. Use protective gloves when using razor.

## SECTION IX TROUBLESHOOTING

<b>PROBLEM</b>	<b>POSSIBLE CAUSE</b>	<b>SOLUTION</b>
Sluggish Heater	Obstruction in chimney	Check for and remove obstruction
	Improperly sealed trim kit or direct connect kit	(a) Check trim kit gasketing seal to fireplace and gasket as necessary to seal unit. Gasket under front bottom of stove if needed. (b) Check seal if using direct connect and correct
	Manual damper in chimney is closed	Open manual damper and wire shut with stainless steel wire or remove damper
	Wet or unseasoned wood being burned	Burn dried natural seasoned hard wood
	Poor chimney draft	Improper chimney height or wrong size flue is being used. Cooler temperatures caused by external chimney

<b>PROBLEM</b>	<b>POSSIBLE CAUSE</b>	<b>SOLUTION</b>
High fuel consumption	Improper regulation of draft or inlet air	(a) Close inlet air control as much as possible to maintain desired heat output (b) Check gaskets, reinstall fiberglass gasketing round doors and glass as necessary
	Improper door fitting	Check door gasket, check adjustment of door latch
Backpuffing	Gusts of Wind	(a) Smoke shelf in chimney is filled with creosote & ash (b) Chimney may need wind diverter. Raise chimney for better draft
Smoke rollout when heater door is opened	Wind gusts blowing down the chimney	(a) Smoke shelf in chimney is filled with creosote & ash (b) Chimney may need wind diverter. Raise chimney for better draft
	Opening heater door too fast	Crack door for 15 seconds before fully opening door

# REPLACEMENT PARTS

## PAGE 1

NOTE: For replacement parts use only manufacturer's specified parts.

<b>Description</b>	<b>Quantity</b>	<b>Part No.</b>
1. Door Gold	1	PC212400-G
2. Door Black	1	PC212400-B
3. Door Pewter	1	PC212400-P
4. Door Handle	1	PO210092
5. Retrofit Door Bushing	1	PO210102
6. Thin Spacer	1	PO910104
7. Retrofit Door Handle Spacer	1	PO21SPACER
8. Retrofit Handle Latch	1	PO910106
9. Door Latch Washer	1	PH316916FW
10. Door Latch Screw	1	PH102212FUH
11. Door Roping 3/4"	1	RPFR2LD.750G
12. Glass Gasket	1	RPTKW197X.875GA
13. Door Glass	1	PG2124GL
14. Firebrick	1	PR900050
15. Glass Clips Small	1	PO210767
16. Glass Clip Screws Hex/Washer Slot Machine Screw 10-32 X 1/2"	10	PH103211HWHMC
17. Cotter Pin	3	PH182CPSS
18. Spring Handle	1	PO100150
19. Hearth Trim Black	1	PO810705-BLK

# REPLACEMENT PARTS

## PAGE 2

NOTE: For replacement parts use only manufacturer's specified parts.

<b>Description</b>	<b>Quantity</b>	<b>Part No.</b>
20. Primary Air Plate	1	MF201034
21. Screws for Primary Air Plate to Air Control Rod		
Hex/Washer Slot Machine Screw 10-32 X 1/4"	2	PH103214HWHSM
22. Air Control Rod	1	MF201035
23. Front Air Control Bracket	1	MF740017
24. Screws for Front Air Control Bracket to Stove		
Hex/Washer Self Drilling Screw 1/4-14 X 1"	2	PH14141TEKP
25. Top Baffle Board 1/2" X 9 1/2" X 19"	1	POBPFB01
26. Top Baffle Board 1/2" X 11" X 13 1/8"	1	POBPFB21
27. Font/Rear Air Secondary Tube	2	PS210026
28. Middle Air Secondary Tube	1	PS2100230
29. Rheostat-Opt. <b>-Optional</b>	1	PEBC204
30. Rheostat Knob <b>-Optional</b>	1	PEBC204A
31. Indicator Label <b>-Optional</b>	1	PEKB9724
32. Thermostat 110 disc <b>-Optional</b>	1	PE400132
33. Power Cord <b>-Optional</b>	1	PE400240
34. Strain Relief <b>-Optional</b>	1	PE400320
35. Blower Kit <b>-Optional</b>	1	MA5126715
36. Motor Only <b>-Optional</b>	1	PESBRO84
37. Close Clearance Shields- <b>Optional</b>	1	MA21SHIELD

**NEW BUCK CORPORATION (NBC)**  
**"LIMITED WARRANTY" FOR THE BUCK STOVE**  
**PLEASE READ THIS WARRANTY CAREFULLY**

**PRODUCTS COVERED**

This warranty covers the new Buck Stove heating unit, so long as it is owned by the original purchaser, including optional and standard accessories purchased at the same time, subject to terms, limitations and conditions herein set out.

**PRODUCTS NOT COVERED**

This warranty does not cover the following:  
Glass, Refractory Material, Firebrick or Gaskets.

This Warranty will not cover any damage and/or failure caused by abuse or improper installation of the products covered.

**WARRANTY TIME PERIODS**

**(A) Period I**

For one year from the date of purchase, NBC will replace or repair, at its option, any part defective in materials or workmanship. The costs of parts only are included. The customer pays any labor or transportation charges required.

**(B) Period II**

Thereafter, for period after first year from date of purchase and extending for five years as long as Buck Stove is owned by the original purchaser, NBC will repair or replace, at its option, any part defective in materials or workmanship, with the exception of, electrical motors, wiring, switches, components, optional and standard accessories; and all parts not permanently attached to heating unit. Parts not permanently attached to heating unit are defined as those items designed to be removed from stove, including those removable with common hand tools. The costs of parts only are included. The customer pays any labor or transportation charges required.

**PROCEDURE**

Should you feel that your BUCK STOVE is defective, you should contact any Buck Stove dealer for the name of your nearest authorized Buck Stove service representative, who will instruct you on the proper procedure, depending on which Warranty Time Period (Period I or Period II) applies.



If for any reason you are dissatisfied with suggested procedures, you may contact us in writing at:

New Buck Corporation  
Customer Service Department  
P. O. Box 69  
Spruce Pine, NC 28777  
Email: info@buckstove.com

## CONDITIONS AND EXCLUSIONS

- (A) Replacement of parts may be in the form of new or fully reconditioned parts, at NBC's option.
- (B) There is no other express warranty. All implied warranties of merchantability and fitness for use are limited to the duration of the Express Warranty.
- (C) New Buck Corporation is not liable for indirect, incidental or consequential damages in connection with use of product including any cost or expense of providing substitute equipment or service during periods of malfunction or non-use.  
Some states do not allow the exclusion of incidental or consequential damages, so above exclusion may not apply to you.
- (D) All warranty repairs under this warranty must be performed by an authorized Buck Stove service representative. Repairs or attempted repairs by anyone other than an authorized service representative are not covered under this warranty. In addition, these unauthorized repairs may result in additional malfunctions, the correction of which is not covered by warranty.

## OTHER RIGHTS

This warranty gives you specific legal rights, and you may also have other rights, which vary from state to state.

## OWNER REGISTRATION CARD

The attached Owner Registration Card must be completed in its entirety and mailed within 30 days from the date of purchase or from the date of installation, if installed by a factory certified installer, to New Buck Corporation in order for warranty coverage to begin.

**PLEASE NOTE:** The Owner Registration Card must contain the Authorized Buck Stove Dealer Code Number and the Certified Installer's number (if applicable) for warranty coverage to begin.

To be completed by selling distributor/ dealer/ customer:

Name \_\_\_\_\_  
(Last) (First)

Address \_\_\_\_\_

City \_\_\_\_\_ State \_\_\_\_\_ Zip \_\_\_\_\_

*CUSTOMER EMAIL::* \_\_\_\_\_

**MODEL 21** - Serial Number \_\_\_\_\_

Date of Installation: Day \_\_\_\_\_ Month \_\_\_\_\_ Year \_\_\_\_\_

Installer's Name \_\_\_\_\_

Installer's Certification Number \_\_\_\_\_

Dealer's Name \_\_\_\_\_

City \_\_\_\_\_ State \_\_\_\_\_ Zip \_\_\_\_\_