

OPERATING MANUAL

Model: S2700 Mega Mix™

HERO
INNOVATIVE COLOR TECHNOLOGY



5 Gallon High Speed Multi Can Paint Shaker

WARNING: DO NOT OPERATE THIS EQUIPMENT WITHOUT READING
AND UNDERSTANDING ALL SAFETY AND OPERATING INSTRUCTIONS

© Copyright 2011 of ICTC Holdings Corp.

Part #: OM-S2700
Version Oct. 2013

I.C.T.C. Holdings Corporation / HERO Products Group
Factory located at: 720 Eaton Way Delta, B.C. Canada V3M 6J9
Ph: (604) 522-6543 Fax: (604) 522-8735 Email: sales@hero.ca Web: www.hero.ca
U.S.A. Address: P.O. Box 75 Custer, Washington 98240-0075

TOLL FREE: (800) 494-4376

PRECAUTIONS AND GENERAL INFORMATION



This machine is **NOT EXPLOSION PROOF**.



Shaking or cleaning with a **FLAMMABLE SUBSTANCE** can cause an **EXPLOSION**.



BE SURE TO REMOVE SHIPPING BOLTS/BRACKETS BEFORE OPERATING THE SHAKER.



In the event of spillage, **CONSULT PAINT CAN SPILL CLEAN UP SECTION.**



ALWAYS make sure the lids to any can or pail being mixed are on tight before placing them into the Shaker.



When mixing multiple cans at the same time, verify that all cans are of the same height. Small variances in height may cause cans and/or the shaker to be damaged due to incomplete clamping action.



ALWAYS be sure to use the rubber spacer pads (provided) on metal and plastic pails to minimize "oil canning".



ALWAYS be sure to use the bail hold down strap (provided) on cans or pails with bail handles.



The Shaker is designed to operate only when the door is closed. **DO NOT ATTEMPT TO ALTER ELECTRICAL INTERLOCK MECHANISM.**



Repair **IMMEDIATELY** a failure of the door interlock or can limit systems to avoid injury from improper operation. Contact the Manufacturer or Certified Service Personnel.



Connect main power cord only to a **DEDICATED ELECTRICAL CIRCUIT** free from any other electronic equipment.



DO NOT USE AN EXTENSION CORD TO RUN THE SHAKER. POSSIBLE FAILURE AND/OR DAMAGE COULD RESULT.



The main motor is equipped with an **AUTOMATIC THERMAL OVERLOAD** device. In the event the motor stops running due to overload, it will automatically reset itself when the motor returns to normal operating temperature.



When not in use for extended period of time, ensure that the machine, including the power cord, is properly stored in a way that is protected from damage.

TABLE OF CONTENTS

Precautions and General Information.....	ii
Table of Contents.....	iii
List Of Drawings & Pictures	v
List of Tables.....	vi
1. Set Up Instructions.....	1
1.1 General Installation.....	1
1.2 Leveling.....	3
1.3 Electrical Connections.....	4
1.4 Controls And Functions.....	4
1.4.1 Descriptions.....	4
1.4.2 Signal Light (LED) Function.....	5
2. Operating Instructions.....	6
3. General Maintenance.....	7
3.1 Daily.....	7
3.2 Weekly.....	7
3.3 Bi-Annually.....	7
4. Trouble Shooting.....	9
5. Repair Instructions.....	12
5.1 Remove And Replace Side Panels.....	12
5.1.1 To Remove Panels.....	12
5.1.2 To Replace Panels.....	12
5.2 Remove And Replace Top Cover.....	12
5.2.1 To Remove Top Cover.....	12
5.2.2 To Replace Top Cover.....	12

TABLE OF CONTENTS

5.3	Remove And Replace Electronic Panels.....	13
5.3.1	To Remove Electronic Panels.....	13
5.3.2	To Replace Electronic Panels.....	13
5.4	Remove And Replace Door Assembly.....	13
5.4.1	To Replace Door Assembly.....	13
5.4.2	To Replace Door Assembly.....	13
5.5	Remove And Replace Top Pressure Plate.....	14
5.5.1	To Remove Top Pressure Plate.....	14
5.5.2	To Replace Top Pressure Plate.....	14
5.6	Belt Adjustment.....	14
5.7	Paint Spill Clean Up.....	15
5.8	Pressure Plate Tang Replacement.....	15
5.8.1	To Replace Pressure Plate	15
5.9	Installing Transformer / Relay Box.....	16
5.9.1	To Remove Transformer.....	16
5.9.2	To Install Transformer.....	16
5.10	Flange Bearing Replacement.....	16
5.10.1	To Remove Flange Bearing.....	16
5.10.2	To Install Flange Bearing.....	16
5.11	Actuator Replacement.....	17
5.11.1	To Remove Actuator.....	17
5.11.2	To Install Actuator.....	17
5.12	Actuator Cable Replacement.....	19
5.12.1	To Remove Actuator Cable.....	19
5.12.2	To Replace Actuator Cable.....	19
5.13	Can Shelf Replacement	20
5.13.1	To Remove Can Shelf.....	20
5.13.2	To Replace Can Shelf.....	20
5.14	Counterweight Replacement	21
5.14.1	To Remove Counterweight.....	21
5.14.2	To Replace Counterweight.....	20
5.15	Main Motor Replacement.....	22
5.15.1	To Remove Main Motor.....	22
5.15.2	To Replace Main Motor.....	22
6.	Parts Detail	23
7.	Complete Parts Lists.....	35
8.	Preparing Shaker for Shipping.....	39-40

DRAWINGS AND PICTURES

Figure 1.1- Bracket For Shipping.....	1
Figure 1.2- Upper Shipping Bracket.....	2
Figure 1.3– Adjustable leveling wheel.....	3
Figure 1.4- Control Board.....	5
Figure 2.5- Can positioning On Can Shelf.....	6
Figure 3.6- Inner Main Frame.....	8
Figure 5.7- Adjust Belt.....	14
Figure 5.8- Crank shaft assembly.....	14
Figure 5.9- Actuator a	17
Figure 5.10- Actuator b.....	18
Figure 5.11- Actuator Cable Replacement	19
Figure 6.12- Can Shelf Assembly.....	23
Figure 6.13- Control Arm Assembly.....	23
Figure 6.14- Door & Door Lock Assembly.....	25
Figure 6.15- Crank Shaft Assembly.....	26
Figure 6.16- Idler Pulley Assembly.....	27
Figure 6.17-Control Cabinet Assembly	28
Figure 6.18-Main Frame Assembly.....	30
Figure 6.19-Front Panel Assembly.....	32
Figure 6.20-Control Board.....	33
Figure 6.21-Wiring diagram.....	34

LIST OF TABLES

Table 4.1-Trouble Shooting.....	9
Table 4.2-Trouble Shooting.....	10
Table 4.3-Trouble Shooting.....	11
Table 6.4-Can Shelf Assembly.....	24
Table 6.5-Door & Door Lock Assembly.....	25
Table 6.6-Crank Shaft Assembly.....	26
Table 6.7-Idler Pulley Assembly.....	27
Table 6.8-Control Cabinet Assembly.....	29
Table 6.9-Main Frame Assembly.....	31
Table 7.10-Can Shelf Assembly.....	35
Table 7.11-Door & Door Lock Assembly.....	36
Table 7.12-Idler Pulley Assembly.....	36
Table 7.13-Crank Shaft Assembly.....	37
Table 7.14-Control Cabinet Assembly.....	37
Table 7.15-Main Frame Assembly.....	38

1. SET UP INSTRUCTIONS

1.1 GENERAL INSTALLATION

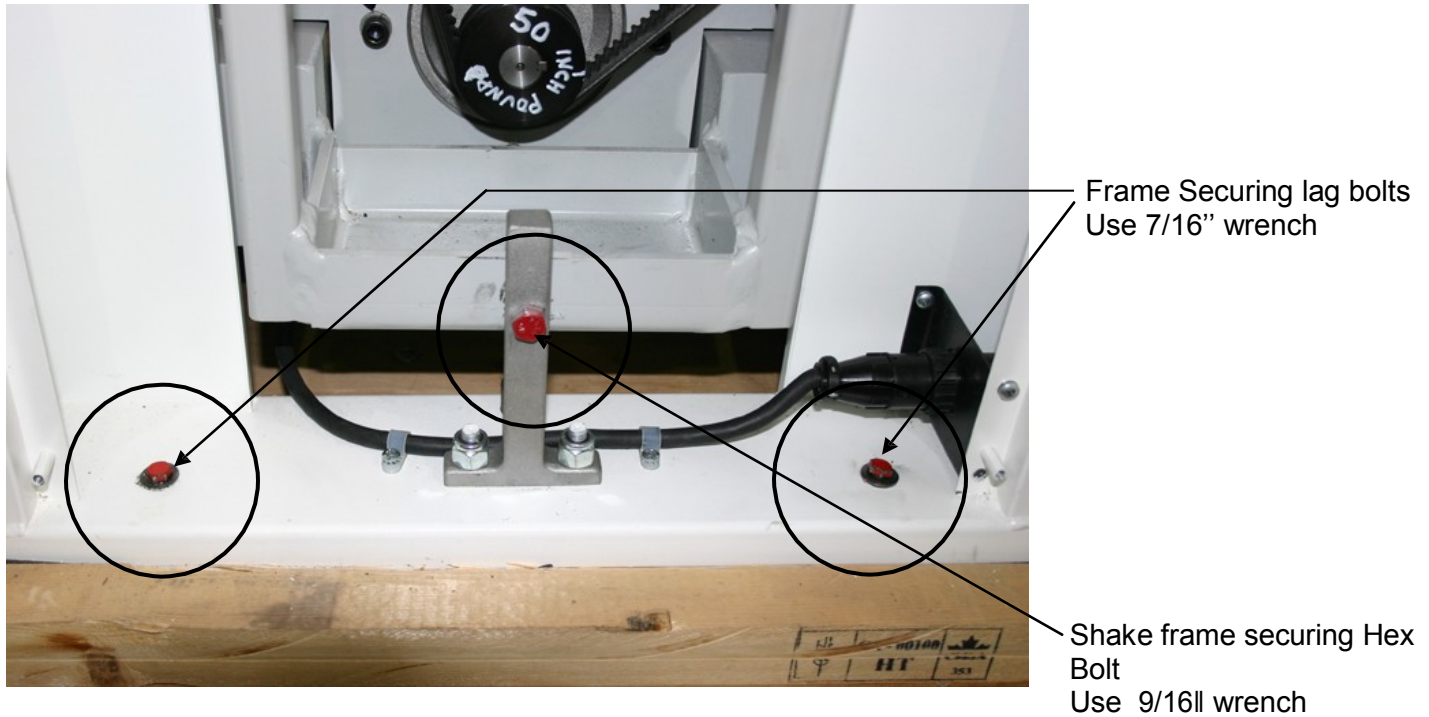

Figure 1.1 - Bottom Shipping Bracket and frame securing bolts

1. **VISUALLY INSPECT** your new HERO S2700 Paint Shaker for any external and concealed damage. Should any damage be noted, a Hidden Damage Report must be filed by the consignee. **DO NOT DELAY IN FILING THE REPORT FORM.**

CONTACT HERO CUSTOMER SERVICE BEFORE PROCEEDING, IF DAMAGE IS FOUND.

NOTE: COMPLETE STEPS 2 THROUGH 6 ONLY IF THE SHAKER HAS NOT BEEN REMOVED FROM THE WOODEN SHIPPING SKID AND PLACED ON THE FLOOR AT THIS POINT. IF IT HAS, PROCEED TO STEP #7.

2. Remove the two (2) side panels.
3. Using a 7/16" socket wrench, unbolt the four (4) lag bolts at each bottom corner of the Shaker. (See Figure 1.1) These lag bolts secure the shaker to the shipping skid. They are identified by red paint markings.
4. Unbolt the two (2) lag bolts holding the 2" x 3" wooden brace at the front of the Shaker.

NOTE: CHECK THAT THE FRONT FEET OF THE SHAKER ARE THREADED UPWARDS BEFORE ATTEMPTING REMOVAL OF THE SHAKER FROM THE SKID.

5. You will now require two (2) or more people to safely remove the Shaker from the skid. Carefully roll the Shaker towards the front of the skid until it is equally on and off. Tilt Shaker forward until it makes contact with the floor **BE CAREFUL THAT IT DOES NOT ROLL AND TIP OVER.** Have a helper pull the skid from beneath the Shaker and carefully lower the rear of the Shaker to the floor. Have your helper push against the rear (just below top cover of Shaker) to ease lowering. **DO NOT LIFT UP ON THE CAN SHELF OR DOOR ASSEMBLY WHILE MOVING SHAKER.**

1. SET UP INSTRUCTIONS

6. Remove the 2 frame securing hex head bolt. Using a 9/16" socket wrench, unbolt the two (2) hex head bolts, one on each side of the shaker located at the bottom center of the shaker. These bolts secure the shaker frame to the outer frame base. They are identified by red paint markings. (See Figure 1.1)

NOTE: SAVE THESE CAP SCREWS IN CASE THE SHAKER IS SHIPPED TO ANOTHER LOCATION OR RETURNED FOR SERVICE.

7. Remove the four (4) 9/16" hex head bolts and lock washers securing the shipping braces identified by red paint markings. Location of shipping braces are on top side-to-side of can shelf assembly. (See Figure 1.2)

NOTE: SAVE THESE HEX HEAD BOLTS, WASHERS AND BRACES IN CASE THE SHAKER IS SHIPPED TO ANOTHER LOCATION OR RETURNED FOR SERVICE.

8. The door assembly is hinged on the left side. You will need a small nail to release the door latch on the right. Remove the door assembly by opening the door all the way to the left and then lifting off hinges.



Figure 1.2 - Upper Shipping Bracket

9. The miscellaneous parts box is located in the shake tray. This box contains all accessories shipped with the machine: it includes; 2 x front foot rubber pads, bail spring, stainless outer can shelf with 5 mounting screws, and the plastic molded quart tray. To remove this box you may need to wait until all shipping brackets have been removed and the control boards are plugged in so you can raise the can clamp shelf.
10. Install stainless steel outer can shelf. Position outer can shelf in lower front door opening of the Shaker. Locate the 5 Phillips mounting screws.
11. Holding outer can shelf in place, install three (3) Phillip head screws (with lock washers) securing the lower portion of the can shelf to the shakers frame. Do not tighten all the way until the 2 top mounting screws are in place.

NOTE: A DROP OF PAINT, OR A REMOVABLE THREAD LOCK ON THE THREADS WILL HELP IN PREVENTING THE SCREWS FROM LOOSENING.

12. Install the two (2) Phillip head screws in the far top corners of the outer can shelf, securing the top portion of the outer can shelf to the shakers frame. You will need to remove the rubber door bumper on the right side in order to screw in the top right side of the can shelf.
13. Place the Shaker in its desired location and proceed to level Shaker. (See Leveling instructions).

1. SET UP INSTRUCTIONS

1.2 LEVELING

1. **INSTALL front black rubber foot pads:** First turn the two front feet lock nuts down so they are at the bottom of the foot. (See Fig 1.3.) Then with a 9/16 open-end wrench turn both front feet down until they just touch the floor. Then carefully tilt the Shaker backwards allowing the placement of a 2" x 4" block of wood under the front of the Shaker. Rest the Shaker on the wooden block. Install the black rubber foot pads under each front foot. Then remove the 2" x 4" block of wood. This should set the front roller approximately 1/8" off of the floor.

Note: Recommended minimum gap between the floor and the front wheel is 1/32" of an inch.

2. **LEVELING** can be checked by placing a level on top of the cabinet. Check for left-to-right leveling as the variance of different flooring may require one side of the Shaker to be positioned higher or lower than the other. Raise or lower front feet to level shaker.
3. **Then adjust for vibration and noise.** To reduce vibration it is recommended to adjust front feet while the machine is shaking a 5 gallon pail. Adjust front feet by small increments one at a time turning until the machine vibrates the least and noise is reduced. When the best setting is found tighten the lock nuts on the feet so that the position does not change.

Note: This Shaker is very HEAVY. KEEP fingers and toes clear from the bottom of the Shaker when resting back on the floor.

Note: With the shaker properly leveled, it will not walk or vibrate excessively during operation. If the Shaker does walk or vibrate excessively, check the leveling and re-adjust the shaker feet as needed.



Lock nut in down position. This will need to be turned back up when proper height setting is found.

Figure 1.3 – Front Foot on black rubber pad

1. SET UP INSTRUCTIONS

1.3 ELECTRICAL CONNECTION

1. Using a Phillips screwdriver, remove the two (2) screws that secure the electronic panel to the top cover. Swing the electronic panel forward. (Figure 1.4, pg 5)
2. With printed circuit boards facing up, plug in the two (2) wire connectors into their respective housings. Listen for the inter-lock "click" to ensure a positive connection.
3. Swing the electronic panel back toward the top cover.
4. Holding the electronic panel in place, replace the two (2) screws (with lock washers).
5. Plug power cord into properly grounded receptacle. Ensure cord is routed in a way that it is protected from damage.

Grounding Instructions:

This product should be grounded. In the event of an electrical short circuit, grounding reduces the risk of electric shock by providing an escape wire for the electric current. This product is equipped with a cord having a grounding wire with an appropriate grounding plug. The plug must be plugged into an outlet that is properly installed and grounded in accordance with all local codes and ordinances.

WARNING – Improper installation of the grounding plug can result in a risk of electric shock. When repair or replacement of the cord or plug is necessary, do not connect the grounding wire to either flat blade terminal. The wire with insulation having an outer surface that is green with or without yellow stripes is the grounding wire.

Check with a qualified electrician or serviceman if the grounding instructions are not completely understood, or if in doubt as to whether the product is properly grounded. Do not modify the plug provided; if it will not fit into the outlet, have the proper outlet installed by a qualified electrician.

This product is for use on a nominal 120V/60 Hz circuit (Europe: 230V/50 Hz), and has a grounding plug similar to the plug illustrated. Only connect the product to an outlet having the same configuration as the plug. Do not use an adapter with this product.

Your Shaker has a 3/4 HP motor which, when starting, requires 10.2 amps in the 110 volt model (less in the 220 volt version). The rating decal lists motor HP size; this label is located at rear of machine near power cord. If label is missing, check the rating plate attached to the motor for your motor's HP rating and electrical requirements.

WE RECOMMEND A 15 AMP DEDICATED CIRCUIT FOR THE SHAKER.

The use of an extension cord will void the warranty.



Symptoms of inadequate power:

- chattering power relay
- starts shaking slowly, then goes to normal speed
- blows main circuit breaker in fuse panel
- pitted/burned power relay contacts

1.4 CONTROLS AND FUNCTIONS

1.4.1 DESCRIPTIONS

1. **EMERGENCY STOP** (Part #HL1101-40)
Main power switch: Push to shut "OFF" power. Turn clockwise to turn power "ON".
2. **TIMER** (Part #HL1101-39)
Push button to set from 30 seconds to 9 minutes.
Example: 0=30 seconds 1=1 minutes 5=5 minutes
3. **START** (Part #HL1101-37)
Push to start mixing sequence.
4. **STOP** (Part #HL1101-38)
Push to stop mixing sequence, or to open door when Shaker is idle.

1.4.2 SIGNAL LIGHT (LED) FUNCTION (VIEWABLE ONLY WITH OPERATING PANEL IN DOWN POSITION)

1. When the emergency switch is first turned on, the red and yellow LEDs come on for a couple of seconds. Then the green LED flashes on for a second. After all lights are off.
2. When the start button is pressed the top pressure plate comes down, the red LED flashes on for a second and the green LED stays on.
3. During the shake cycle both LEDs ,green and red, stay on.
4. The Yellow LED comes on as the top pressure plate returns home.

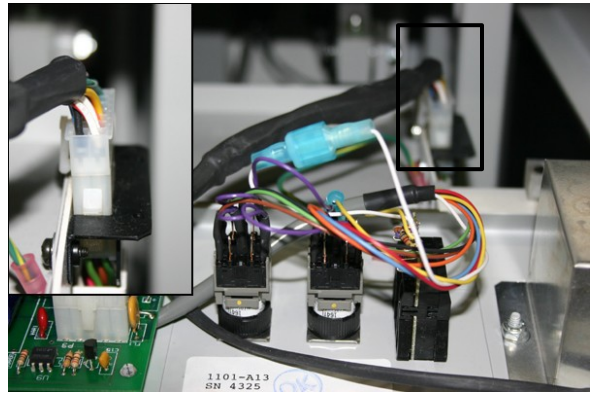
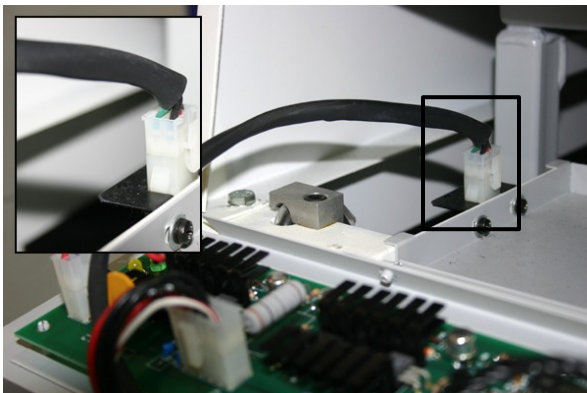
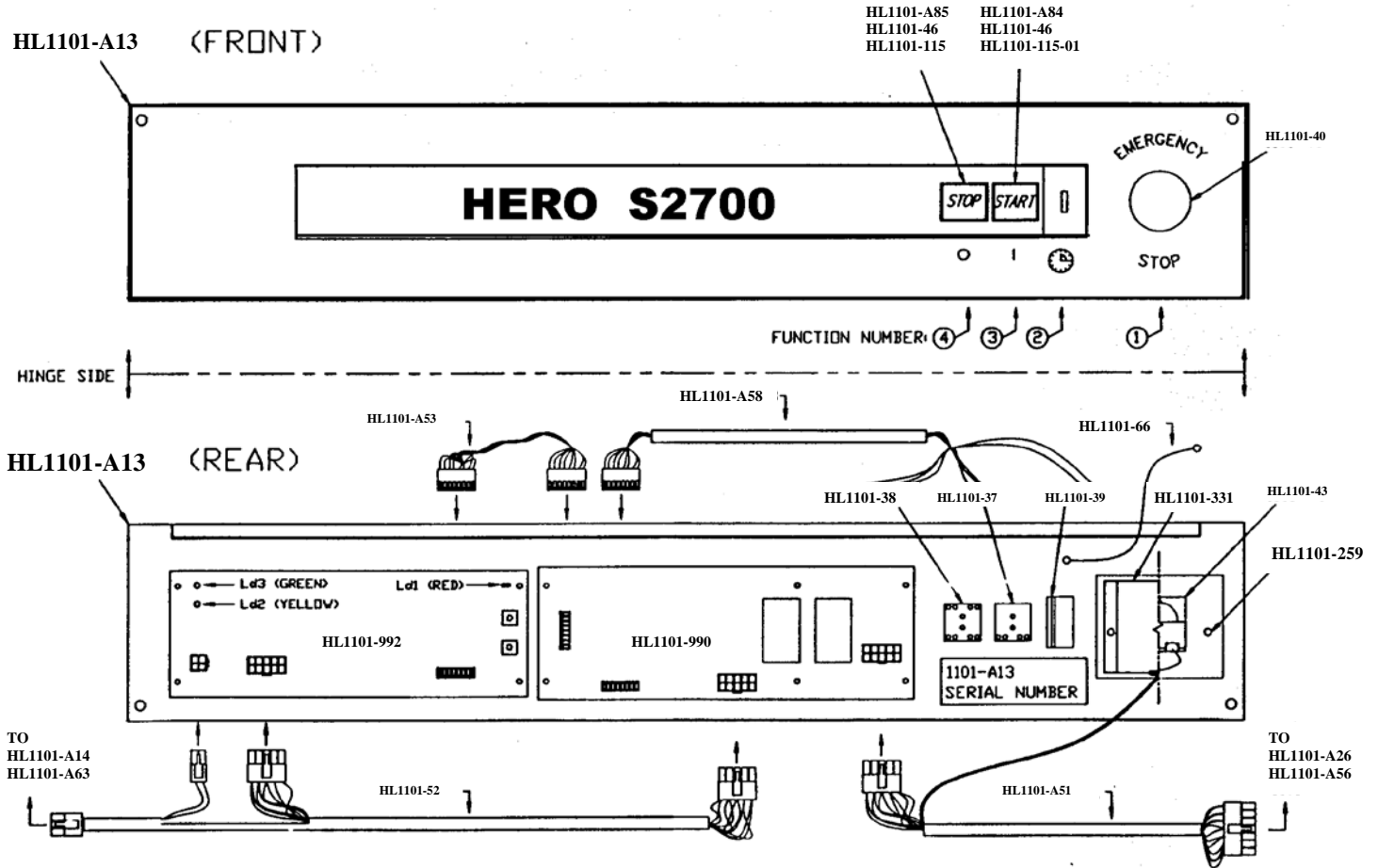
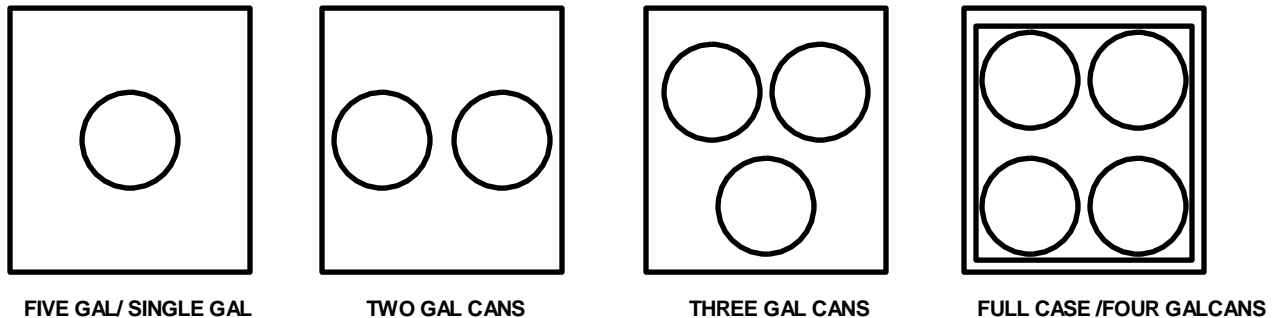

Figure 1.4 - Control board

2. OPERATING INSTRUCTIONS

1. Turn and release the **EMERGENCY STOP** switch. The red STOP switch should be illuminated.
2. Press STOP switch to open the door and set timer to desired time for shaking.
3. Load can (s) or one (1) full case into Shaker's can shelf. Be sure that container or case is centered on the can shelf. (See can positioning diagram).
NOTE 1: THERE IS A LIP ON THE TOP CLAMPING PLATE - BE SURE THAT THE CONTAINER IS INSIDE THAT LIP.
**NOTE 2: ONLY USE SPACER PAD FOR FIVE GALLON AND 20 LITER CANS
ON METAL PAIL USE ON BOTTOM
ON PLASTIC PAIL USE ON TOP**
4. Using bail hold down strap (provided), attach to containers bail handle and secure underneath the can shelf.
5. Close the door and Press the START switch. Shaker will automatically clamp the container, then mix for desired time, stop, and open door for next container.
6. Press emergency stop button for emergencies or stop button to stop before timed cycle.

NOTE: DO NOT ATTEMPT TO OPEN DOOR DURING OPERATION. AN INTERLOCK PREVENTS SHAKER FROM RUNNING IF THE DOOR IS OPENED. DO NOT OVERRIDE THIS SAFETY FEATURE.



**NOTE: ONLY USE SMALL CAN ADAPTOR FOR QUART AND LITER CANS.
CENTER CANS FROM CENTER HOLE POSITION OUTWARDS.**

Figure 2.5 - Can Positioning On Can Shelf (Top View)

3. GENERAL MAINTENANCE

**NOTE: UNPLUG THE POWER CORD BEFORE ATTEMPTING TO CLEAN OR SERVICE THE SHAKER, OR COMPLETING THE PROCEDURES LISTED BELOW.
WHEN CLEANING SHAKER, ONLY USE NON-FLAMMABLE SOLVENTS, SOAP AND WATER OR ANY NON FLAMMABLE CLEANER.**

3.1 DAILY:

1. Check can shelf and rubber pad on top pressure plate for paint residue. Clean if necessary with a damp cloth.
2. Wipe down the outside of the shaker with a damp cloth. This will clean most paint marks and drips.

3.2 WEEKLY:

1. Make a visual inspection of the Shaker. Check to see if any foreign objects fell between the can shelf and the front frame of Shaker. If necessary, remove any foreign objects.
2. Check door assembly and clean. Remove door for detailed cleaning if necessary (See 5.4 page 13). Also, check for damage and replace if necessary. Note: If using a paint stripper to clean the front door ensure that it is safe for use on Lexan.
3. Ensure the power cord is routed in a way that it is protected from damage.

3.3 BI-ANNUALLY:

TO BE PERFORMED BY AN AUTHORIZED SERVICE REPRESENTATIVE

1. Make a general visual inspection, including checking for loose screws, nuts, and bolts.
2. Remove rear panel (See 5.1 page 12) and check V-Belt adjustment (See 5.6 page 14).
3. Remove both side panels (See 5.1 page 12). Using a high quality grease (PLEWS Multi-Purpose grease #30-124, NLGI Grade 2) or equivalent. Grease the two pillow blocks and the two flange bearings(See page 8 diagrams). The two pillow block bearings can be accessed from the rear of the shaker while the two flange bearings can be accessed from both sides of the Shaker. (Figure 3.5 next page)

NOTE: CARE SHOULD BE TAKEN WHEN RE-GREASING BEARINGS NOT TO OVERFILL THE BEARINGS. OVER-GREASING CAN LEAD TO OVERHEATING AND/OR UNSEALING THE BEARING SEALS. ONLY FILL THE BEARINGS UNTIL YOU JUST SEE NEW GREASE DISCHARGING FROM THE SIDES OF THE BEARINGS. PUMP GREASE GUN SLOWLY.THROUGHOUT THIS PROCEDURE.

4. Remove top cover (See 5.2 page 12) and grease the four (4) grease fittings on the two (2) control arms (ref A8), using the same type grease as in step four above. (Figure 3.5 next page)

NOTE: IT MAY BE NECESSARY TO SLIGHTLY LOOSEN THE TWO (2) FRONT SHOULDER BOLTS ON CAN SHELF TO ALLOW GUN TO PUMP GREASE.

5. Replace top cover (See 5.2 page 12) and any other panels

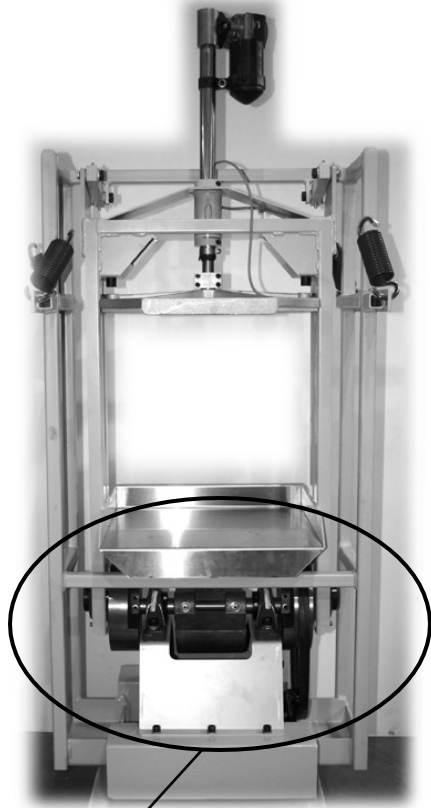

Two pillows block

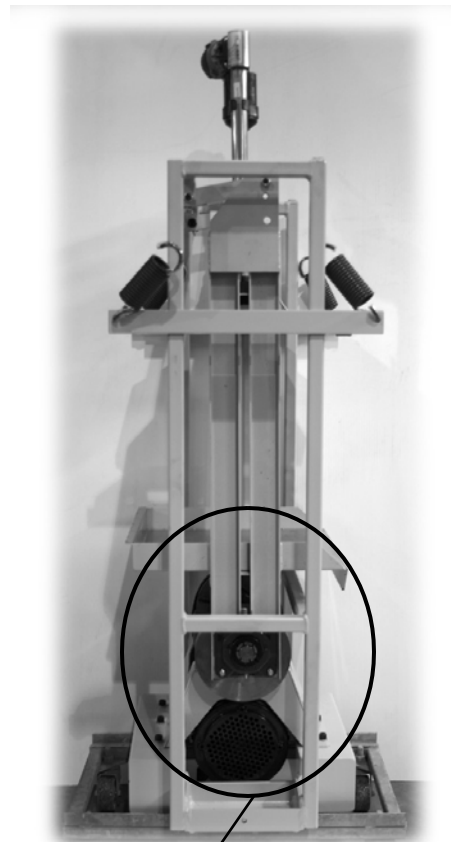

Two flange bearings

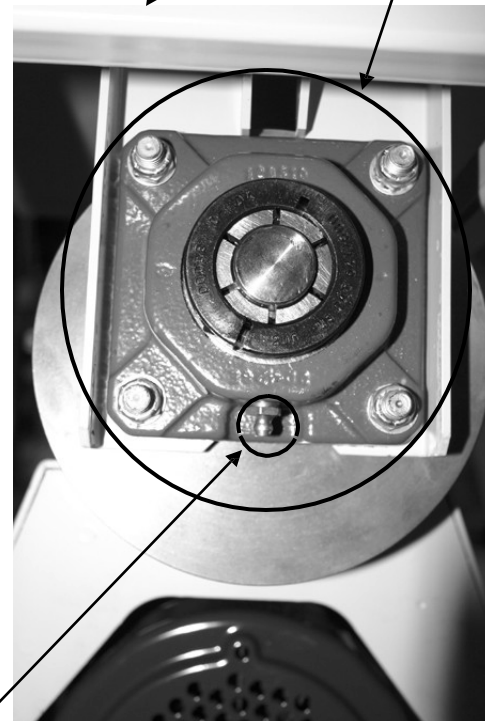
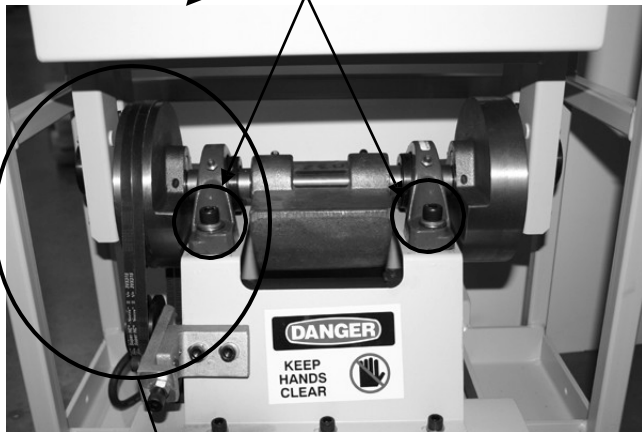

Grease fittings

Figure 3.5 - Inner Main frame

4. TROUBLE SHOOTING

Table 4.1 -Trouble Shooting

NOTE: UNLESS MARKED BY AN ASTERISK (*) THE REMEDIES IDENTIFIED ARE TO BE CARRIED OUT BY AN AUTHORIZED SERVICE REPRESENTATIVE.

PROBLEM	CAUSE	REMEDY
Shaker will not start.	<ol style="list-style-type: none"> 1. Shaker not plugged in.* 2. Check power supply. 3. Door not closed.* 4. Power cord damaged. 5. Main fuse failure. 6. Emergency stop switch is depressed.* 7. Door lock safety switch failure. 8. Lower door hinge tab not contacting lower safety switch. 9. Lower door hinge safety switch failure. 10. Power supply logic board failure. 	<ol style="list-style-type: none"> 1. Plug in power cord.* 2. Shaker should be plugged into a dedicated 15 amp circuit. (No other items should be plugged in) 3. Close door to operate.* 4. Repair and or replace. 5. Replace. 6. Twist switch to reset.* 7. Repair or replace. 8. Check tab on lower door hinge to make sure that it is contacting switch in door frame. Earlier models used a plastic hinge. Replace with new metal hinge. 9. Repair or replace switch. 10. Replace.
Pressure plate will not move from home position.	<ol style="list-style-type: none"> 1. Door safety switch failure. 2. Broken can limit switch. 3. Broken wire in actuator cable. 4. Broken wire in can limit switch cable. 5. Faulty actuator board. 6. Faulty actuator motor. 7. Wires are reversed on actuator cable. 	<ol style="list-style-type: none"> 1. Check and or replace door safety switch. 2. Check and or replace. 3. Check and or replace. 4. Check and or replace. 5. Disconnect pg2 on the actuator board and press the start button. If the green light comes on it means that the actuator board is good. If unit runs it means that the board is no good. 6. Check and or replace. 7. Green/Yellow wire on top terminal. Black wire on bottom terminal. <p>If pressure plate will not move, disconnect the green terminal on the door switch. The green light on the actuator board should come on.</p>

4. TROUBLE SHOOTING

Table 4.2 -Trouble Shooting

PROBLEM	CAUSE	REMEDY
Pressure plate will not return home.	<ol style="list-style-type: none"> 1. Pressure plate rubbing against frame rails. 2. Faulty circuit boards. 3. Loose actuator motor. 4. Broken actuator shaft (thrust tube). 	<ol style="list-style-type: none"> 1. Remove side panels and check pressure plate guides. Replace if necessary. 2. Replace if necessary. 3. Make sure that actuator motor is tightly fastened to actuator shaft. 4. Replace actuator shaft (thrust tube). <p>If no lights on the actuator board go on, check the fuse located on the bottom of the control cabinet. The brown wire on the power contactor relay may have pulled off or requires re-crimping. If lights do not go on then the actuator board need to be replaced .</p>
Pressure plate moves up (about 1ll) during shake mode.	<ol style="list-style-type: none"> 1. Faulty can limit switch or broken wiring. 2. Broken Actuator cable (rare). 	<ol style="list-style-type: none"> 1. Check and or replace if necessary. 2. Check and or replace if necessary.
Shaker runs before clamping on container.	<ol style="list-style-type: none"> 1. Missing or damaged upper rubber stops. 2. Actuator tube is bent or binding. 3. Loose actuator motor. 4. Pressure plate is binding on frame rails. 	<ol style="list-style-type: none"> 1. Replace. 2. Check alignment of actuator tube and make sure that pressure plate is able to move freely up or down through the frame rails. 3. Check to make sure that actuator motor is secure onto actuator tube. 4. Check to see if pressure plate tangs (older models) or sleeves are damaged. Replace if necessary.
Shaker will not shut off.	<ol style="list-style-type: none"> 1. Power contactor relay is defective. 2. Faulty circuit board, possibly C23 if blue (on older models). 	<ol style="list-style-type: none"> 1. Replace if necessary. 2. Replace if necessary.
Stop lamp is illuminated, but start lamp will not illuminate.	<ol style="list-style-type: none"> 1. Start switch bulb burnt. 2. Door switch failure. 3. Can limit switch Failure. 4. Broken wire in actuator cable. 5. Faulty circuit board. 	<ol style="list-style-type: none"> 1. Check and or replace if necessary. 2. Check door micro switch for continuity. Replace if necessary. 3. Check switch for continuity. Replace if necessary. 4. Check and or replace if necessary. 5. Check and or replace if necessary.

4. TROUBLE SHOOTING

Table 4.3 -Trouble Shooting

PROBLEM	CAUSE	REMEDY
Stop and or start buttons do not illuminate but Shaker runs.	1. Lamps are burnt.	1. Check and or replace if necessary.
Shaker shuts off while mixing.	1. Door switch is faulty or wiring is loose. 2. Shaker is drawing too many amps. 3. Motor capacitors faulty.	1. Check door switch for continuity and check wiring. 2. Make sure that Shaker is plugged into a dedicated 15 or 20 amp circuit. 3. Replace capacitor.
Shaker starts slowly then increases speed and runs normal or squeals during start up.	1. Loose belts on motor.	1. Check belt tension, tighten and or replace belts if necessary.
Shaker shake motor receives voltage but will hum and not run.	1. Excessive voltage drop. 2. Faulty motor capacitors. 3. Power contactor relay is damaged.	1. Check power supply. Shaker be on a 20 amp dedicated circuit. 2. Replace if necessary. 3. Replace if necessary.
Excessive Shaker vibration.	1. Shaker is not balanced. 2. Can pad stuck on top of pressure plate.	1. Check Shaker to see if it is balanced properly. Should be checked with a level. 2. Remove stuck can pad from pressure plate.
Shaker starts, runs for a few seconds and blows out the circuit breaker.	1. Shaker is drawing too many amps. 2. Motor capacitor failure.	1. Shaker must be on a dedicated 20 amp circuit. 2. Replace.
Shaker is making a loud knocking noise.	1. Loose pad on pressure plate. 2. Flange (side) bearings need to greased or are worn. 3. Upper control arms need to grease or are worn.	1. Repair or replace if necessary. 2. Grease flange (side) bearings, replace if noise continues. 3. Grease upper control arms, replace if noise continues.

5. REPAIR INSTRUCTIONS

NOTE: ALL REPAIRS ARE TO BE CARRIED OUT BY AN AUTHORIZED SERVICE REPRESENTATIVE EXCEPT FOR 5.4, REMOVE AND REPLACE DOOR ASSEMBLY, AND 5.7, PAINT SPILL CLEAN-UP, WHICH MAY BE CARRIED OUT BY THE USER.

5.1 REMOVE AND REPLACE SIDE & REAR PANELS

5.1.1 TO REMOVE PANELS:

1. **WARNING: UNPLUG THE POWER CORD BEFORE PROCEEDING.**
2. Using a Phillips #2 screwdriver, remove the six (6) screws that secure side panel to Shaker frame.
3. Repeat step two (2) above, if removing other side panel.

5.1.2 TO REPLACE PANELS:

1. Place side panel in opening on Shaker frame.
2. Holding panel in place, replace the six (6) screws (with lock washers).
Repeat for other side panel if necessary.
3. Plug power cord back into wall outlet.

5.2 REMOVE AND REPLACE TOP COVER

5.2.1 TO REMOVE TOP COVER:

1. **WARNING: UNPLUG THE POWER CORD BEFORE PROCEEDING.**
2. Using a Phillips #2 screwdriver, remove the two (2) screws that secure the electronic panel to the top cover.
Leave electronic panel plugged in and swing forward.
3. Using a 7/16" socket wrench, unbolt the two (2) hex head bolts located towards front corner sides of Shaker.
4. Slide back top cover 2" overcoming finger tabs at rear top corners of Shaker.
5. Lift off top cover, being careful not to hit the linear actuator. The top cover will be heavy - please do not drop or scratch it. Place top cover to one side at this time.

5.2.2 TO REPLACE TOP COVER:

1. Lift top cover over linear actuator, and replace on Shaker frame.
2. Slide top cover forward to engage finger tabs at rear top corners of Shaker, thus locking rear of cover to Shaker frame.
3. Replace the two (2) 7/16" hex head bolts (with lock washers).
4. Swing back electronic panel to front of top cover.
5. Holding electronic panel in place, replace the two (2) screws (with lock washers).
6. Plug power cord back into wall outlet.

5. REPAIR INSTRUCTIONS

5.3 REMOVE AND REPLACE ELECTRONIC PANEL

5.3.1 TO REMOVE ELECTRONIC PANEL:

1. **WARNING: UNPLUG POWER CORD BEFORE PROCEEDING.**
2. Using a Phillips #2 screwdriver, remove the two (2) screws that secure the electronic panel to the top cover.
3. Swing electronic panel forward, unplug the two (2) wire connectors from the housings affixed to the frame.
4. Using a flathead 1/4" screwdriver, remove the four (4) screws that secure the electronic panel to the frame.
5. Disconnect ground wire.

5.3.2 TO REPLACE ELECTRONIC PANEL:

1. Place electronic panel in front of Shaker's top cover opening. While holding electronic panel in your hand with printed circuit boards facing up, replace the four (4) screws (with lock washers) back in.
2. Plug in the two (2) wire connectors into their respective housings. Be sure to hear the inter-lock "click", ensuring a positive connection.
3. Attach ground wire.
4. Swing back electronic panel to front of top cover.
5. Holding panel in place, replace the two (2) screws (with lock washers).
6. Plug power cord back into wall outlet.

5.4 REMOVE AND REPLACE DOOR ASSEMBLY

5.4.1 TO REMOVE DOOR ASSEMBLY:

1. Having door assembly open, swing completely to the left (180 degrees). Do not force door beyond this point.
2. Apply an upward pressure with your hand under bottom of door. Door should slide up hinged pins and disconnect from Shaker frame.

5.4.2 TO REPLACE DOOR ASSEMBLY:

1. Hold door assembly in hands with door hinge pins facing away from body.
2. Locate upper and lower hinge pin blocks (left front side of Shaker) and insert hinge pins into pin blocks. Door should move freely with no binding when installed properly.

5. REPAIR INSTRUCTIONS

5.5 REMOVE AND REPLACE TOP PRESSURE PLATE

5.5.1 TO REMOVE TOP PRESSURE PLATE:

1. **WARNING: UNPLUG POWER CORD BEFORE PROCEEDING.**
2. Open door assembly, using a #2 pencil, small nail, or credit card (depending on Shaker door latch) which you can slide through the door latch on the right side to open the door.
3. Using a 5/16" hexagonal bar wrench, remove the one (1) 5/16" hexagonal cap screw that secures the top pressure plate to the linear actuator. Be careful when removing top pressure plate - hold firmly when loosening.

5.5.2 TO REPLACE TOP PRESSURE PLATE:

1. Place top pressure plate tangs between can shelf frame rails.
2. Holding top pressure plate against linear actuator, replace the one (1) 5/16" hexagonal cap screw (with lock washer).
NOTE: BE SURE TO TORQUE THIS SCREW TO 30 FOOT/POUNDS.
3. Close door assembly.
4. Plug power cord back into wall outlet.

5.6 BELT ADJUSTMENT

1. **WARNING: UNPLUG POWER CORD BEFORE PROCEEDING.**
2. Remove rear panel (See 5.1 page 12).
3. Inspect all drive components.
4. Check belt deflection. Deflection should be approximately 3/8" and no greater than a 1/2". If in specification, go to step 8. Continue if out of tolerance.
5. Using a 5/16" hexagonal bar wrench, loosen the two (2) 5/16" hexagonal cap screws (items #3 and #5 on drawing shown Fig 5.8.)

NOTE: YOU MAY HAVE TO LOOSEN THE 9/16" LOCKNUT ON ITEM 4.

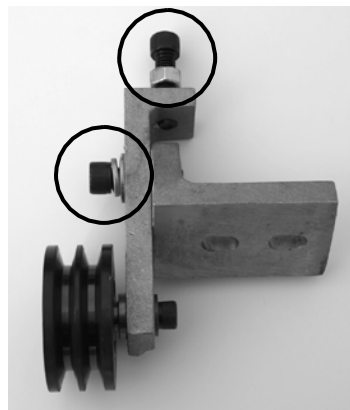

Figure 5.7- Adjust belt

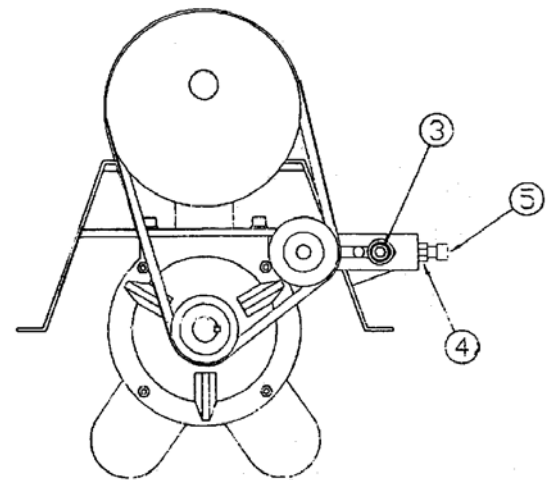

Figure 5.8 -Crank shaft assembly

6. Adjust 5/16" hexagonal cap screw #5 for a belt deflection of 3/8" to 1/2". Keeping the tension on the hexagonal cap screw, tighten the 9/16" locknut down #4.
7. Re-tighten 5/16" hexagonal cap screw #3, recheck belt deflection.
NOTE: RECOMMENDED TORQUE ON HEXAGONAL CAP SCREW IS 30 FOOT/POUNDS.
8. Replace rear panel (See 5.1 page 12).
9. Plug power cord back into wall outlet.

5. REPAIR INSTRUCTIONS

5.7 PAINT SPILL CLEAN-UP:

1. WARNING: UNPLUG POWER CORD BEFORE PROCEEDING.

NOTE: CLEAN SHAKER USING NONFLAMMABLE SOLVENTS. BUT NEVER USE ANY FLAMMABLE SOLVENTS.

2. Open door assembly, using a #2 pencil, small nail, or credit card (depending on Shaker door latch) which you can slide through the door latch on the right side to open the door.
3. Remove container, or cans from Shaker's can shelf.
4. Using a damp rag soaked in soapy lukewarm water, wipe off can shelf/tray and top pressure plate, also any other surfaces.
5. Remove door assembly (See 6.5 page 13) wash with soapy lukewarm water.
6. Replace door assembly(See 6.5 page 13) .
7. Plug power cord back into wall outlet.

5.8 PRESSURE PLATE TANG SLEEVE REPLACEMENT (PART # HL1101-3032)

1. WARNING: UNPLUG POWER CORD BEFORE PROCEEDING.

2. Open door assembly, using a #2 pencil, small nail, or credit card, slide through door latch on the right side to open door.
3. Having door assembly open, swing completely to the left (180 degrees). Do not force door beyond this point.
4. Apply an upward pressure with your hand under bottom of door. Door should slide up hinged pins and disconnect from Shaker frame. Place door aside,
5. Using a 5/16" hexagonal bar wrench, remove the one 3/8 - 16 x 1" hex cap screw that secures the pressure plate to the linear actuator. Be careful when removing pressure plate, hold firmly when loosening.
6. Place pressure plate on a flat work surface. Be sure pressure plate is facing up, rubbing pad facing towards you.
7. Remove the two screws that secure the old -U" shaped clips on both sides of the tangs, or -ears" of pressure plate. Do not discard screws.
8. Place one end of six inch tubing into hot water, or use heat gun/blow dryer.
 - a) If you using hot water - let sit for five minutes.
 - b) If you are using heat gun/blow dryer - be sure not to burn, or overheat.
9. Once heated, push heated end of tubing onto one tang, or -ear" of pressure plate. Be sure that tubing is flush against the shoulder of pressure plate. Cut off excess tubing.
10. Repeat step nine for the other tang, or -ear" of pressure plate.
11. Using a small knife or drill bit, make a hole, for placement of screw that was removed from step seven. Be sure that both screw holes on the pressure plate tang, or -ear" are clean to receive screw.
12. Install screws into each side pressure plate tang, or -ear". Be sure not to over tighten.
13. Place one 1-1/4" piece of shrink tubing over tubing, and screw.
Holding in place with screwdriver, heat shrink tubing with heat gun/blow dryer. Be sure not to burn or over heat.
14. Repeat this step for other tang, or -ear" of pressure plate.

5.8.1 TO REPLACE TOP PRESSURE PLATE

15. Verify that dried paint or obstructions are removed from the can shelf frame rails.
16. Place pressure plate tangs between can shelf frame rails. Be sure that HERO Products Group logo is facing towards you.
17. Holding pressure plate against linear actuator, replace the one 5/16" hex cap screw (with lock washer).
18. Hold door assembly in hands with door hinge pins facing away from body.
19. Locate upper and lower door hinge pin blocks (left front side of Shaker) and insert hinge pins into pin blocks. Door should move freely with no binding when installed properly.
20. Close door assembly. Plug power cord back into wall outlet. Shaker is now ready for operation.

5. REPAIR INSTRUCTIONS

5.9 INSTALLING TRANSFORMER/RELAY BOX

5.9.1 TO REMOVE TRANSFORMER/RELAY BOX:

1. **WARNING: UNPLUG POWER CORD BEFORE PROCEEDING.**
2. Remove top cover.
3. Facing front of Shaker, remove the three (4) wire connectors located underneath right side of transformer/relay box.
NOTE: THESE CONNECTORS HAVE A POSITIVE LOCK COUPLING RING, TURN COUNTERCLOCKWISE UNTIL POSITIVE LOCK DISENGAGES. THE SAFETY LOCK MECHANISM IS RATHER HARD TO RELEASE.
4. Using a #2 Phillips screwdriver, remove ground strap from Shaker frame.
5. Using a 1/4" slotted screwdriver, remove the two (2) screws securing the hooded cover to the transformer/relay box.
6. Depending on style, using either a 11/32" socket or a slotted screwdriver, remove either the four (4) hex head locknuts or slotted screws that secure the transformer/relay box to the Shaker frame.

5.9.2 TO INSTALL TRANSFORMER/RELAY BOX:

1. Facing rear of Shaker, mount the transformer/relay box to the Shaker frame. Secure by using the four (4) 11/32" hex head locknuts or slotted screws. Be sure to have connector receptacles towards your left when facing rear of Shaker when installing.
2. Facing front of Shaker, plug in the three (4) wire connectors located underneath right side of relay box.
NOTE: THESE CONNECTORS HAVE A POSITIVE LOCK COUPLING RING, TURN CLOCKWISE UNTIL POSITIVE LOCK ENGAGES. THE SAFETY LOCK MECHANISM IS RATHER HARD TO ENGAGE.
3. Using a #2 Phillips screwdriver, connect ground strap to Shaker frame.
4. Replace top cover(See 5.2 page 12).
5. Plug power cord back into wall outlet.

5.10 FLANGE BEARING REPLACEMENT

5.10.1 TO REMOVE FLANGE BEARING:

1. **WARNING: UNPLUG POWER CORD BEFORE PROCEEDING.**
2. Remove side panel*.
3. Using a 9/16" socket wrench, remove the four (4) hex head lock nuts and lock washers securing the flange bearing housing from Shaker frame rails.
4. Using a 1/8" hexagonal or Torx bar wrench, loosen the two (2) 1/8" set screws. (Some bearings may have only one (1) set screw).
5. Holding the flange bearing housing at right angles to the shaft, slide the bore of bearing off the shaft.
NOTE: DO NOT STRIKE BORE OR BEARING AND DO NOT SUBJECT THE UNIT TO ANY SHOCK.

5.10.2 TO INSTALL FLANGE BEARING:

1. Check shaft - shaft should be clean, and free of nicks and burrs.
2. Lubricate bearing bore/shaft O.D., (outer diameter).
3. Mount the flange bearing housing by holding at right angles to the shaft, slide the bore of bearing on the shaft. Be sure not to twist the bearing in its' housing.
NOTE: WHEN INSTALLING FLANGE BEARING, BE SURE THAT GREASE FITTING IS FACING DOWN OR AT THE SIX O'CLOCK POSITION.
4. Using a 9/16" socket wrench, install the four (4) hex head lock nuts (with lock washers) securing the flange bearing housing to the Shaker frame rails.
5. Fit the eccentric collar on the inner-ring shoulder bore of bearing and then insert the hexagonal bar wrench securely into the hexagonal hole of the set screw, and tighten the two (2) screws uniformly. (Some bearings may have only one (1) set screw).

5. REPAIR INSTRUCTIONS

Note: Recommended torque on set screw is 5.5 - 5.8 foot/pounds. Also, be sure that eccentric collar is square and tight against the inner-ring shoulder bore of bearing.

6. Install side panel.
7. Plug power cord back into wall outlet.

5.11 ACTUATOR REPLACEMENT

5.11.1 TO REMOVE ACTUATOR:

1. **WARNING: UNPLUG POWER CORD BEFORE PROCEEDING.**
2. Remove top cover.
3. Remove top pressure plate and block (See ref A) .
4. Using a #1 Phillips screwdriver, remove the three (3) screws securing the plastic access cover to actuator motor body.(See ref 1 in Figure 5.9)
5. Disconnect the two (2) wires with quick disconnect terminals from motor. (See ref 2 in figure 5.9)
6. Disconnect the white terminal housing from actuator cable to terminal housing of can limit switch cable. (See ref 3 in Figure 5.9)
7. Using a 3/16" flathead screwdriver, remove the two (2) screws securing the wire clamp to actuator motor body. (See ref 4 in Figure 5.9)
8. Using a 3/16" flathead screwdriver, remove the screw securing the ground clamp to actuator tube body. Ground clamp is located above the pressure plate and just below cross member of the can shelf assembly. (See ref 5 in Figure 5.9)
9. Using a 3/16" Allen wrench, loosen the two (2) 3/16" hexagonal cap screws from can shelf assembly collar supporting the actuator. (See ref 6 in Figure 5.9)
10. Remove actuator by sliding upwards through the can shelf assembly collar

5.11.2 TO INSTALL ACTUATOR:

1. With actuator motor facing upwards and pointing towards the right, slide actuator downwards through the can shelf assembly collar.
2. Align the bottom of the actuator tube body 7/8 below the can shelf assembly collar. Holding in place, tighten the two 3/16 hexagonal cap screws with a 3/16" Allen wrench. These screws are located on the frame assembly collar.
Note: Actuator collar screws should be torqued to 16 foot/pounds.
3. Having ground clamp tang facing downwards, install ground clamp to actuator tube body located just below cross member of can shelf assembly. (See ref 5 in Figure 5.9)
4. Holding ground clamp in place, tighten the 3/16" screw securely using a 3/16" flathead screwdriver.

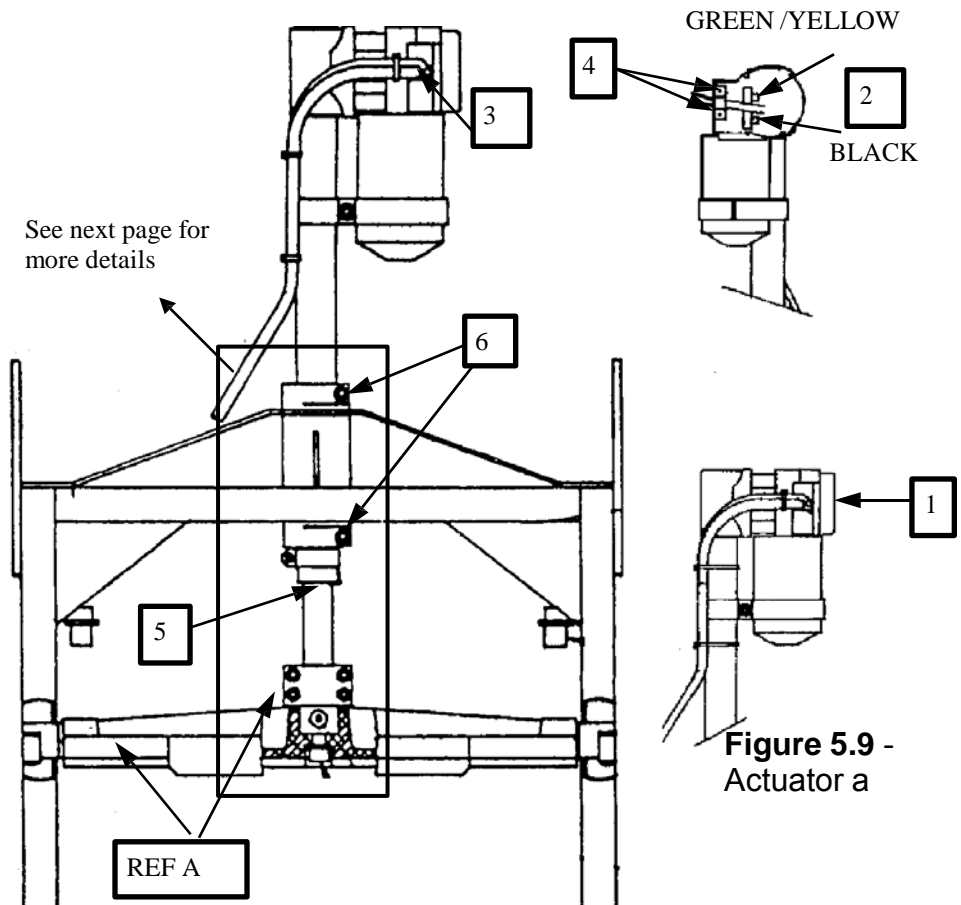
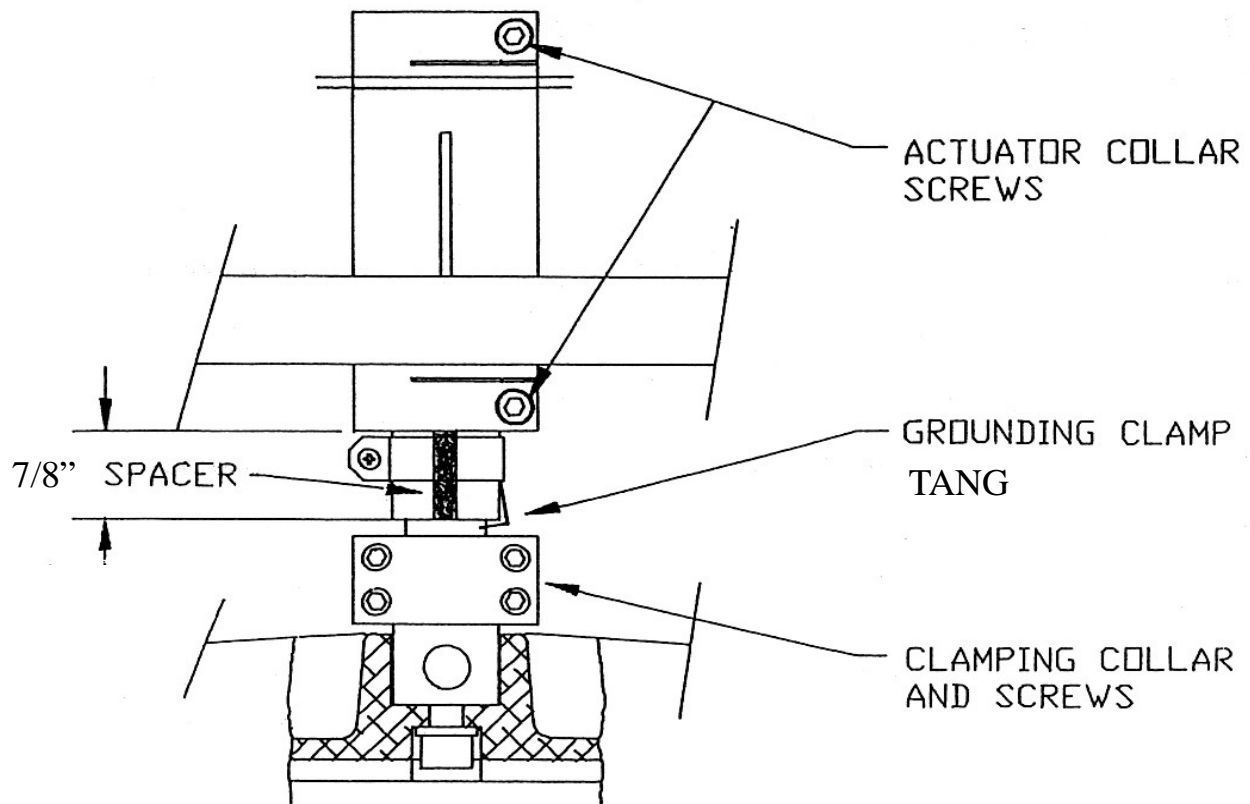

Figure 5.9 -
Actuator a

5. REPAIR INSTRUCTIONS

5. Connect the two (2) quick disconnect terminals from actuator cable to actuator motor body as follows: (See ref 2 in Figure 5.9)
 - a. Yellow with green strip wire to top labeled 53a
 - b. #3 wire to bottom tab labeled 53e
6. Connect the white terminal housing from actuator cable to terminal housing of can limit switch cable. Be sure to hear the inter-lock "click" ensuring a positive connection.
7. Using a flathead screwdriver, install the two (2) screws securing actuator cable to wire clamp to actuator motor body. (See ref 4 in Figure 5.9)
8. Using a #1 Phillips screwdriver, install the three (3) screws securing the plastic access cover to actuator motor body. (See ref 1 in Figure 5.9)
9. Install top pressure plate and block. (See ref A in Figure 5.9)
10. Install top cover (See 5.2 page 12).
11. Plug power cord back into wall outlet.



BEFORE

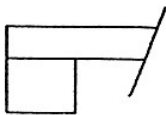

AFTER

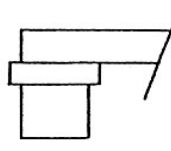

1/8' WASHER

BUMPER

Figure 5.10 - Actuator b

5. REPAIR INSTRUCTIONS

5.12 ACTUATOR CABLE REPLACEMENT

5.12.1 TO REMOVE ACTUATOR CABLE:

1. **WARNING: UNPLUG POWER CORD BEFORE PROCEEDING.**
2. Remove top cover (See 5.2 page 12).
3. Using a #1 Phillips screwdriver, remove the three (3) screws securing the plastic access cover to actuator motor body. (See ref 1)
4. Cut the cable tie, attaching the actuator cable and the can limit switch cable (thin gray cable) together. (See view B, #1)
5. Disconnect the white terminal housing from actuator cable to terminal housing of can limit switch cable.
6. Using a 3/16" flathead screwdriver, remove the two (2) screws securing the cable clamp to actuator motor body.
7. Cut the cable ties attaching the cable to the actuator shaft. (See view B #2 and #3)
Mark the location of the cable ties #2 & #3 holding the actuator cable to the actuator. These need to be reattached later in the same position.
8. Remove the strain relief on the frame. See View C. pinch backside of the strain relief to remove.
9. Disconnect the white connector. See view C. You will have to remove the left side panel and disconnect the two safety switch wires.

5.12.2 TO REPLACE ACTUATOR CABLE:

1. Place actuator cable through the hole on the frame and adjust it so when the cable is bent correctly , its arc lines up with the center of the suspension spring. See view C.
2. Place the strain relief on the cable and assemble into frame. Maintain adjustment of the cable and the center of the spring. See view C. reconnect the safety switch wires. (black = NO ; red =COM)
3. Position the replacement cable through the clamp on the motor head. (See view A).
4. The end of the cable should be even to the end of the male terminals (about 2 inches from the clamp). (See view A).
5. Tighten down the clamp so that the cable is snug.
DO NOT OVERTIGHTEN!
6. Connect the cable wires to the male terminals: (Green / yellow = top terminal) (black = bottom terminal) see view A.
7. Connect the white terminal.
8. Bring the actuator cable across the front of the actuator and form a 90 degree angle. Run it down the actuator shaft with the can limit switch cable. See view B.
9. Install cable ties at three locations : (See view B .) # 1= tie to can limit switch cable. # 2 = tie to actuator shaft 1 inch above the actuator motor clamp. # 3 = tie to actuator shaft 1 inch below the actuator motor clamp.
10. Install the three screws in the motor cap.
6. Install the hood.
7. Connect the power.
8. Resume operation.

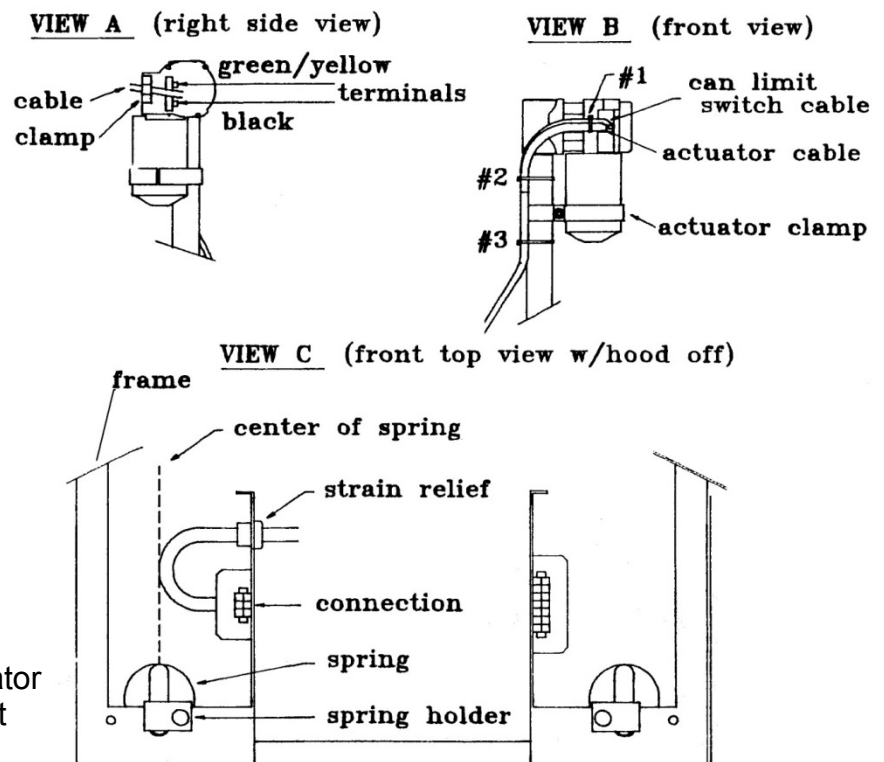

Figure 5.11 - Actuator Cable Replacement

5. REPAIR INSTRUCTIONS

5.13 CAN SHELF REPLACEMENT

5.13.1 TO REMOVE CAN SHELF:

1. **WARNING: UNPLUG POWER CORD BEFORE PROCEEDING.**
2. Remove top cover (See 5.2 page 12).
3. Remove side panels (See 5.1 page 12).
4. Remove rear panel (See 5.1 page 12).
5. Remove flange bearings (See 5.10 page 16).
6. If necessary, remove transformer/relay box (See 5.9 page 16).
7. Using a 3/16" hexagonal bar wrench, remove the two (2) 3/16" hexagonal cap screws securing the front cross bar to cradle assembly frame.
8. Using a 1/4" hexagonal bar wrench and a 9/16" socket wrench, disassemble front portion of control arms from can shelf assembly only.
9. You will now require two (2) people (including yourself) to safely remove the can shelf from Shaker.
10. Carefully lift the can shelf straight up. Place can shelf to one side.
11. Remove top pressure plate (See 5.5 page 14).
12. Remove actuator (See 5.11 page 17).

5.13.2 TO INSTALL CAN SHELF:

1. You will require two (2) people (including yourself) to safely install the can shelf into the Shaker.
Gently place the can shelf on the counterweight stub shafts.
2. Center the can shelf on the counterweight shaft.
3. Install flange bearings (See 5.10 page 16).
4. Using a 1/4" hexagonal bar wrench and a 9/16" socket wrench, assemble front portion of control arms to the can shelf. Grease fittings when finished.
NOTE: RECOMMENDED TORQUE ON HEXAGONAL CAP SCREWS IS 16 FOOT/POUNDS.
5. Install actuator (See 5.11 page 17).
6. Install top pressure plate (See 5.5 page 14).
7. If removed, replace transformer/relay box (See 5.9 page 16).
8. Using a 3/16" hexagonal bar wrench, install the front cross bar to cradle assembly frame using (2) 3/16" hexagonal cap screws.
NOTE: RECOMMENDED TORQUE ON HEXAGONAL CAP SCREW IS 20 FOOT/POUNDS.
9. Install rear panel (See 5.1 page 12).
10. Install side panels (See 5.1 page 12).
11. Install top cover (See 5.2 page 12).
12. Plug power cord into wall outlet.

5. REPAIR INSTRUCTIONS

5.14 COUNTERWEIGHT REPLACEMENT

5.14.1 TO REMOVE COUNTERWEIGHT :

1. **WARNING: UNPLUG POWER CORD BEFORE PROCEEDING.**

2. Remove top cover (See 5.2 page 12).

3. Remove side panels (See 5.1 page 12).

4. Remove rear panel (See 5.1 page 12).

5. Remove can shelf (See 5.13 page 20).

6. Using a 5/16" hexagonal bar wrench, loosen the two (2) 5/16" hexagonal cap screws (items 3 and 5 shown on Motor/Idler assembly drawing). Slide the V-belts off idler and flywheel pulleys, leave to one side. You may have to loosen the 9/16" locknut on item 4.

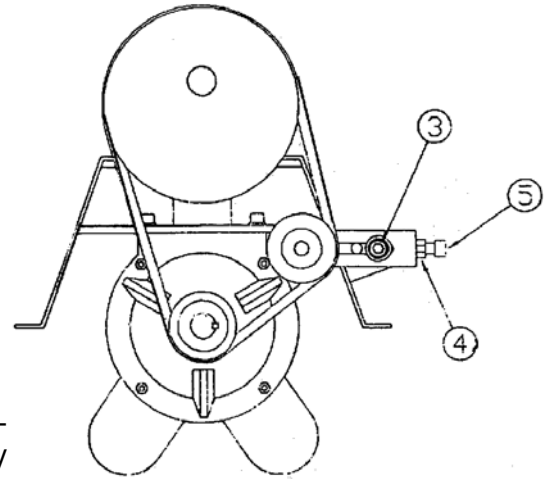

Figure 5.8 -Crank shaft assembly

7. Using a 3/8" hexagonal bar wrench, remove the four (4) 3/8" hexagonal cap screws (with lock washers and flat washers) that secure the counterweight assembly to the motor bridge assembly.

8. Lift up and remove the counterweight assembly, being careful not to drop assembly. Place counterweight to one side at this time.

NOTE:THE COUNTERWEIGHT ASSEMBLY IS VERY HEAVY. KEEP FINGERS CLEAR FROM PINCH POINTS, AS THE COUNTERWEIGHT CAN ROTATE WITHOUT WARNING.

5.14.2 TO INSTALL COUNTERWEIGHT:

1. Place counterweight assembly on top of motor bridge assembly. Center counterweight assembly by lining up pilot holes of pillar block bearings to stud holes on the motor bridge assembly.

NOTE:THE COUNTERWEIGHT ASSEMBLY IS VERY HEAVY. KEEP FINGERS CLEAR FROM PINCH POINTS, AS THE COUNTERWEIGHT CAN ROTATE WITHOUT WARNING.

2. Using a 3/8" hexagonal bar wrench, install the four (4) 3/8" hexagonal cap screws (with lock washers and flat washers) securing the counterweight assembly to the motor bridge assembly.

NOTE: RECOMMENDED TORQUE ON HEXAGONAL CAP SCREWS IS 75 FOOT/POUNDS.

3. Install V-belts on idler and flywheel pulleys.

4. Adjust V-belt (See 5.6 page 14).

5. Install can shelf (See 5.13 page 20).

6. Install rear panel (See 5.1 page 12).

7. Install side panels (See 5.1 page 12).

8. Install top cover (See 5.2 page 12).

9. Plug power cord back into wall outlet.

5. REPAIR INSTRUCTIONS

5.15 MAIN MOTOR REPLACEMENT:

5.15.1 TO REMOVE MAIN MOTOR:

1. **WARNING: UNPLUG POWER CORD BEFORE PROCEEDING**

2. Remove electronics panel (See 1.3 page 4)
3. Remove top cover (See 5.2 page 12)
4. Remove side panels (See 5.3 page 13)
5. Remove rear panel (See 5.6 page 13)
6. Remove can shelf (See 5.13 page 20)
7. Remove counterweight (See 5.14 page 21)
8. Facing right side of Shaker, remove the main motor wire connector and the two (2) strain relief Fasteners located at Shaker's base.

NOTE: THIS CONNECTOR HAS A POSITIVE LOCK COUPLING RING. TURN COUNTERCLOCK WISE UNTIL POSITIVE LOCK DISENGAGES. THE SAFETY LOCK MECHANISM IS RATHER HARD TO RELEASE.

9. Using a 5/16" Allen wrench, remove the six (6) cap screws that secures the motor bridge assembly to the intermediate frame assembly.
10. Lift up and remove the motor bridge assembly, being careful not to drop assembly.
NOTE: THE MOTOR BRIDGE ASSEMBLY IS VERY HEAVY. KEEP FINGERS CLEAR FROM PINCH POINTS.
11. Using a 1/4" hexagonal bar wrench, remove the four (4) cap screws that secures the main motor to the motor bridge. Place both items to one side at this time.

5.15.2 TO INSTALL MAIN MOTOR:

1. Place motor bridge on the main motor. Be sure that the two (2) 3/8" tapped holes on the motor bridge are facing towards the main motor's output shaft.
2. Using a 1/4" Allen wrench, install the four (4) cap screws (with lock washers) securing the bridge to the main motor.
3. Place motor bridge assembly on top of intermediate frame assembly, being careful not to drop assembly.

NOTE: THE MOTOR BRIDGE ASSEMBLY IS VERY HEAVY. KEEP FINGERS CLEAR FROM PINCH POINTS.

4. Using a 5/16" Allen wrench, install the six (6) cap screws securing the motor bridge assembly to the Intermediate frame assembly.
5. Facing right side of Shaker, install the main motor wire connector and the two (2) strain relief's located at shaker's base.

NOTE: THIS CONNECTOR HAS A POSITIVE LOCK COUPLING RING. TURN CLOCKWISE UNTIL POSITIVE LOCK ENGAGES. THE SAFETY LOCK MECHANISM IS RATHER HARD TO ENGAGE.

6. Install counterweight (See 5.14 page 21).
7. Install can shelf (See 5.13 page 20).
8. Install rear panel (See 5.1 page 12).
9. Install side panels (See 5.1 page 12).
10. Install top cover (See 5.2 page 12)
11. Install electronics' panel (See 5.3 page 13)
12. Plug power cord into wall outlet.

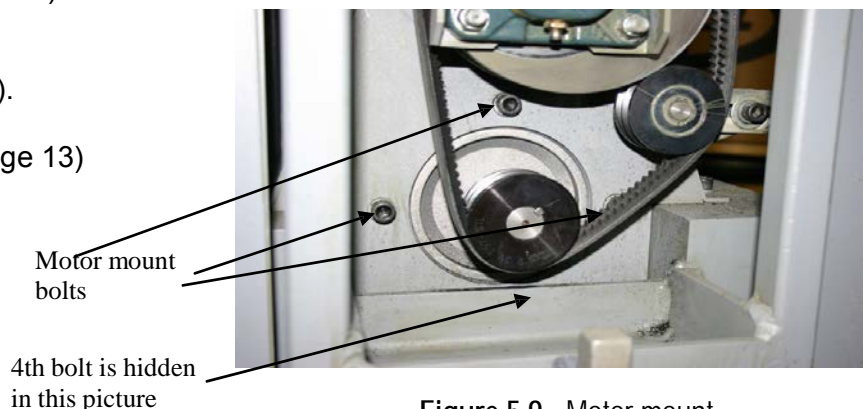

Figure 5.9 - Motor mount

6. PARTS DETAIL

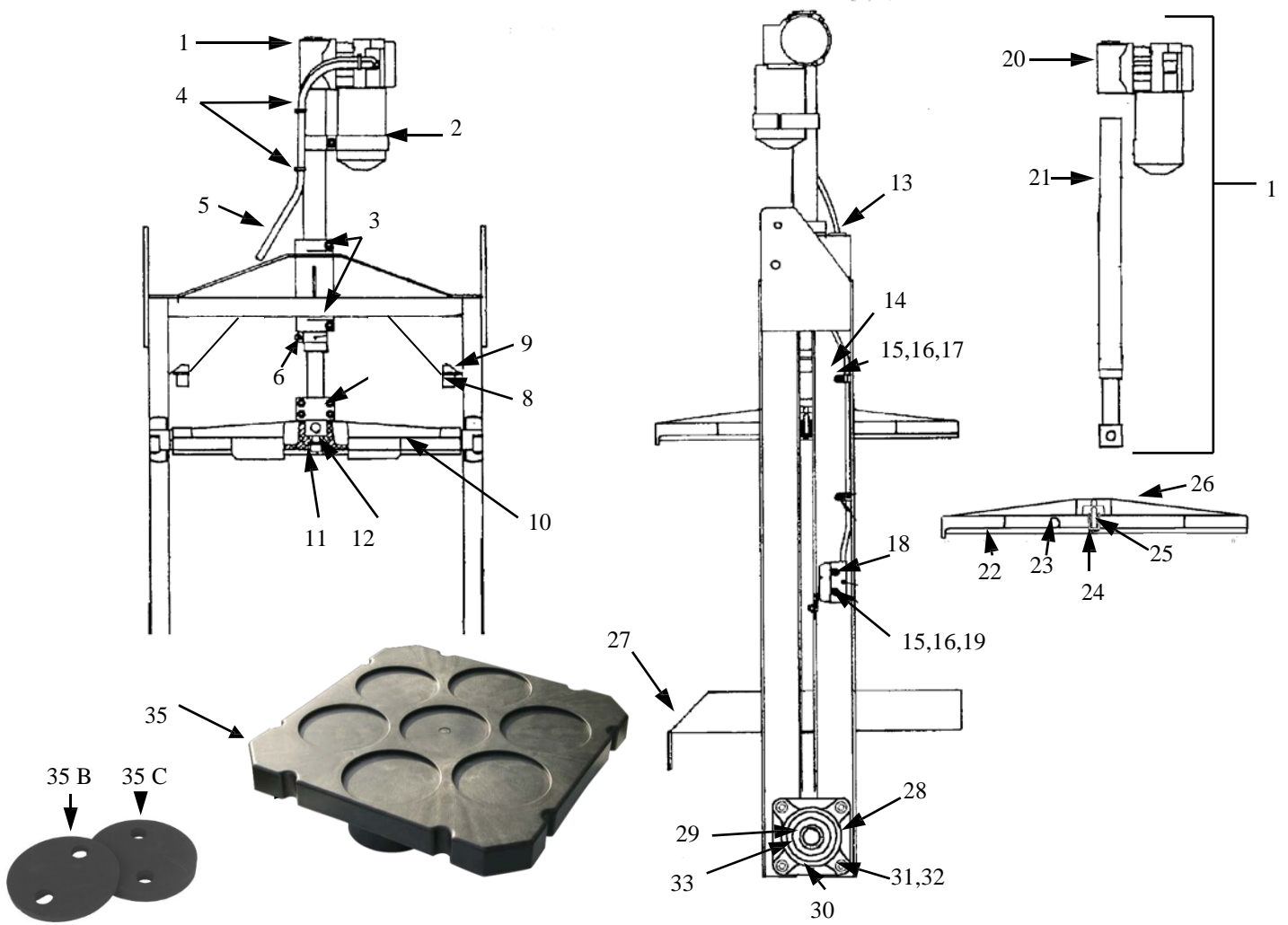

Figure 6.12 - Can Shelf Assembly

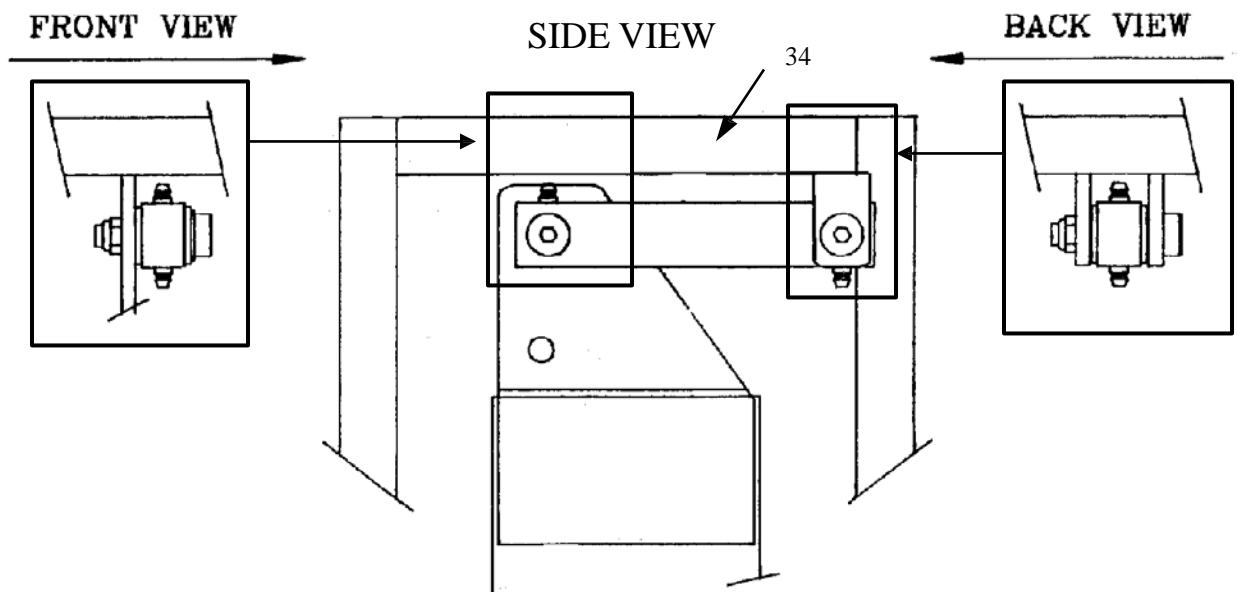

Figure 6.13 - Control Arm Assembly

Table 6.4 - Can Shelf Assembly Description

REF #	PART #	DESCRIPTION	QTY
1	HL1101-A14L	ACTUATOR COMPLETE	1
2	HL1101-A45	ACTUATOR MOTOR CLAMP ASSEMBLY	1
3	HL1101-282	SCREW	2
4	HL1101-138	CABLE TIE	1
5	HL1101-A55UL	ACTUATOR CABLE ASSEMBLY	1
6	HL1101-A10	ACTUATOR GROUND CLAMP	1
7	HL1101-A44	ACTUATOR TUBE CLAMP ASSEMBLY	1
8	HL1101-237	PRESSURE PLATE BUMPER SPACER	2
9	HL1101-232	PRESSURE PLATE BUMPER	2
10	HL1101-A28	PRESSURE PLATE ASSEMBLY COMPLETE	1
11	HL1101-213	SCREW SOCKET HEAD 3/8 X 1"	1
12	HL1101-272	WASHER 3/8"	1
13	HL1101-126	GROMMET	1
14	HL1101-223	CLAMP 1/4"	2
15	HL1101-136	WASHER	4
16	HL1101-256	WASHER LOCK #6	5
17	HL1101-266	SCREW 6-32 X 5/16	2
18	HL1101-A63	CAN LIMIT SWITCH ASSEMBLY	1
19	HL1101-265	SCREW	2
20	HL1101-A81	ACTUATOR MOTOR ASSEMBLY	1
21	HL1101-A79	ACTUATOR TUBE ASSEMBLY, BEFORE S/N 2177	
	HL1101-A79L	ACTUATOR TUBE ASSEMBLY, AFTER S/N 2177	1
22	HL1101-118	RUBBER PAD (PRESSURE PLATE)	1
23	HL1101-3035	PRESSURE PLATE SIDE GUIDES	2
24	HL1101-144	SCREW 10-32 X 3/8", (NOT AVAILABLE) SEE REF # 25A	2
25	HL1101-3034	PRESSURE PLATE TANG SPRINGS, (NOT AVAILABLE) SEE REF # 25A	2
25A	HL1101-3032	PRESSURE PLATE SLEEVE KIT (REPLACES REF # 24 & 25)	KIT
26	HL1101-3033	PRESSURE PLATE (METAL ONLY)	1
27	HL1101-A29	CAN SHELF (METAL ONLY)	1
28	HL1101-102	FLANGE BEARING CW HL1101-109	2
29	HL1101-109	COLLAR FLANGE BEARING	1
30	HL1101-281	GREASE NIPPLE	1
31	HL1101-246	WASHER	4
32	HL1101-248	NUT (NYLOCK) 3/8-16	4
33	HL1101-110	TORX CAP SREW 8-32 X 5/8	2
34	HL1101-A8	CONTROL ARM COMPLETE	2
35	HL1101-A50	QUART ADAPTOR	1
35B	HL1101-234	CAN PAD, 1/2"	ACCESSORY
35C	HL1101-235	CAN PAD, 3/4"	ACCESSORY

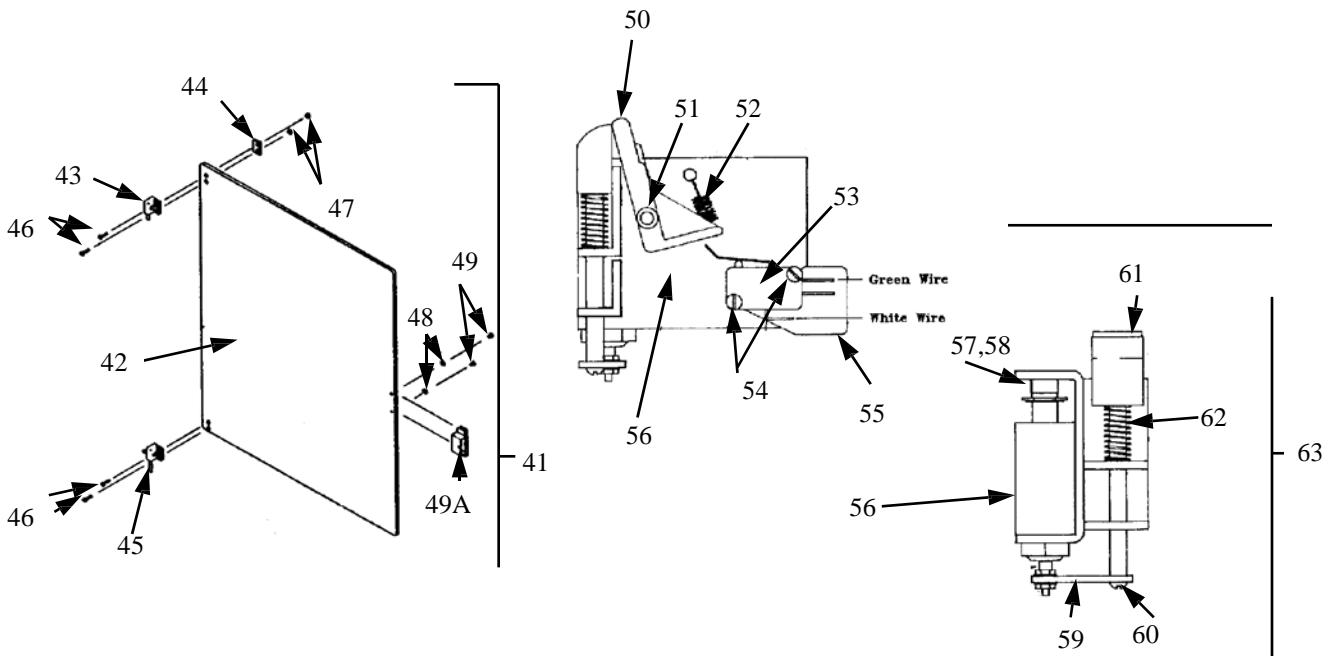

Figure 6.14 - Door & Door Lock Assembly

REF #	PART #	DESCRIPTION	QTY
41	HL1101-A15	DOOR COMPLETE	1
42	HL1101-3008	DOOR PLEXIGLSS ONLY	1
43	HL1101-A20	UPPER DOOR HINGE	2
44	HL1101-4009	PLATE	1
45	HL1101-A21	LOWER DOOR HINGE	1
46	HL1101-276	SCREW	1
47	HL1101-259	NUT	2
48	HL1101-269	WASHER	2
49	HL1101-254	SCREW	2
49A	HL1101-4014	DOOR LOCK SHIELD	1
50	HL1101-3053	LEVER	1
51	HL1101-141	E-RING	1
52	HL1101-4051	SPRING	1
53	HL1101-268	DOOR LOCK SWITCH	1
54	HL1101-151	SCREW 4-40-X-1/2	2
55	HL1101-329	INSULATING PAPER	4
56	HL1101-112	SOLENOID	5
57	HL1101-300	SOLENOID BUMPER	2
58	HL1101-301	SCREW 4-40 X 3/16	1
59	HL1101-4063	DOOR LOCK LINK	2
60	HL1101-150	SCREW 6-32 X 3/8	1
61	HL1101-A33	PLUNGER ASSEMBLY	1
62	HL1101-111	SPRING	1
63	HL1101-A26	DOOR LOCK ASSEMBLY COMPLETE	1

Table -6.5- Door & Door Lock Assembly Description

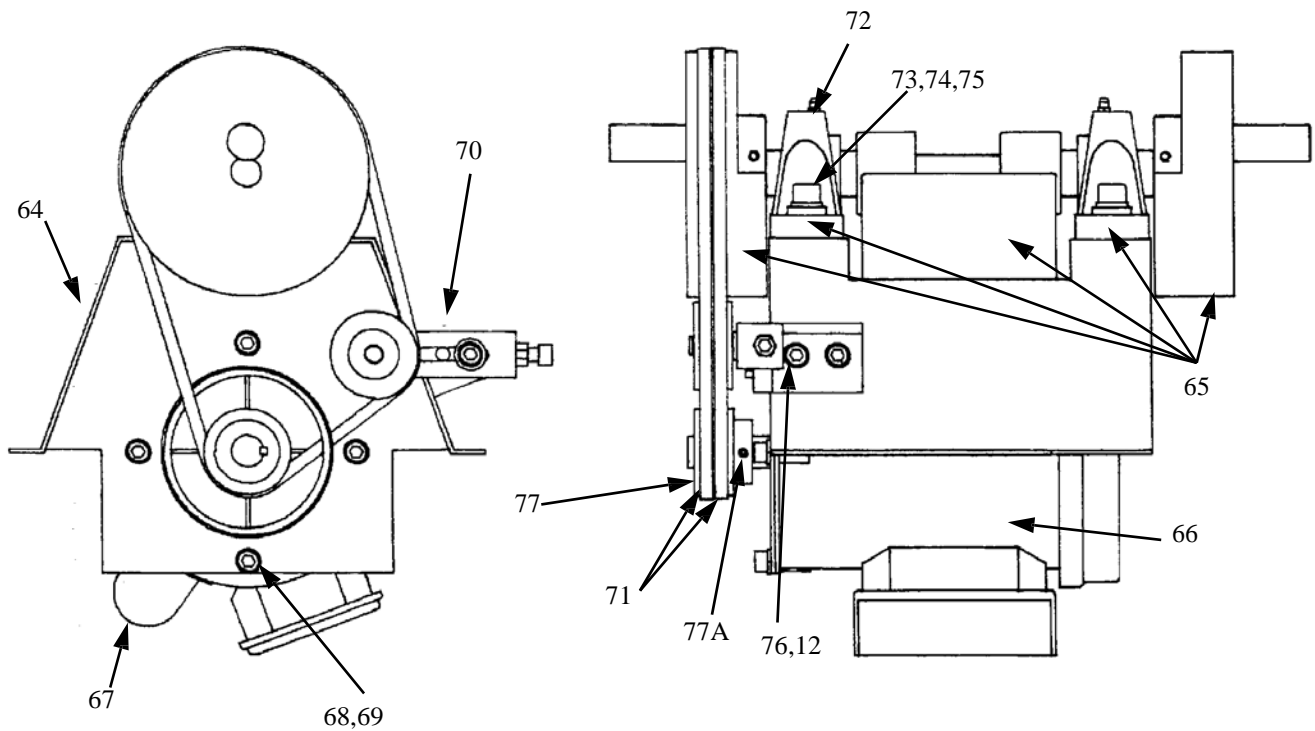

Figure 6.15 - Crank shaft Assembly

REF #	PART #	DESCRIPTION	QTY
	HL1101-A40	MOTOR BRIGE ASSEMBLY C-FACE & COUNTER WEIGHT ASSEMBLY, 110V MOTOR	ASSEMBLY
64	HL1101-A82	MOTOR BRIGE ASSEMBLY C-FACE , AFTER # 2177	1
	HL1101-A5	MOTOR BRIDGE ASSEMBLY, BEFORE SERIAL # 2177	1
65	HL1101-A61	CRANKSHAFT /COUNTERWEIGHT ASSEMBLY	1
66	HL1101-159	MOTOR, 3/4 HP, 110V (SERIAL # 2177 AND HIGHER)	2
	HL1101-101	MOTOR, 110V, (SERIAL # 2176 AND LOWER)	1
67	HL1101-309	MOTOR CAPACITOR	1
68	HL1101-272	WASHER SPLIT 3/8	6
69	HL1101-212	SCREW SOCKET HD 3/8-16 X 3/4	1
70	HL1101-A41	IDLER BRAKET ASSEMBLY	1
71	HL1101-104	V BELT (EACH)	2
72	HL1101-103	BEARING	2
73	HL1101-249	SCREW SOCKET HD 3/8-16 X 1. 1/2	4
74	HL1101-250	WASHER FLAT 1/2	4
75	HL1101-251	WASHER SPLIT 1/2	1
76	HL1101-213	SCREW SOCKET HD 3/8-16 X 1	1
77	HL1101-4040	MOTOR PULLEY, 110 V	1
	HL1101-135	MOTOR PULLEY, 220 V	1
77A	HL1101-310	MOTOR PULLEY SET SCREW, 1/4-20 X 1/4'	1

Table –6.6- Crankshaft Assembly Description

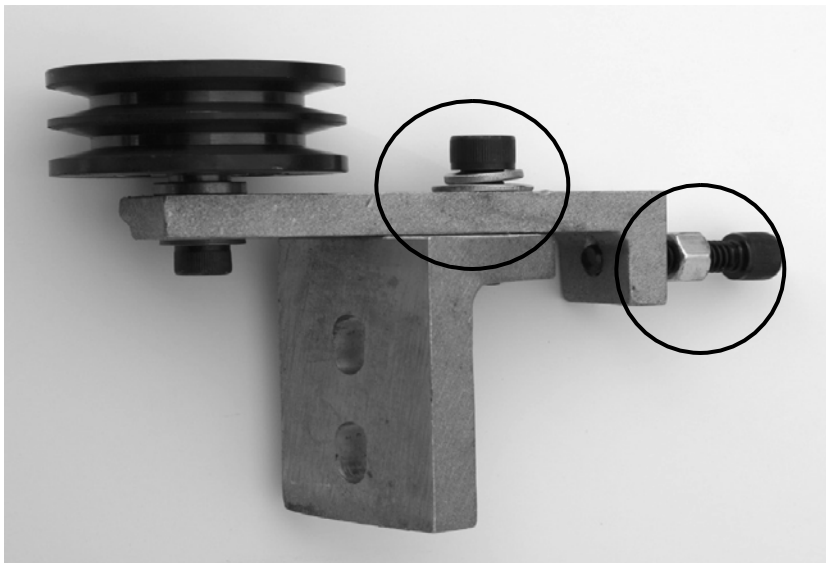
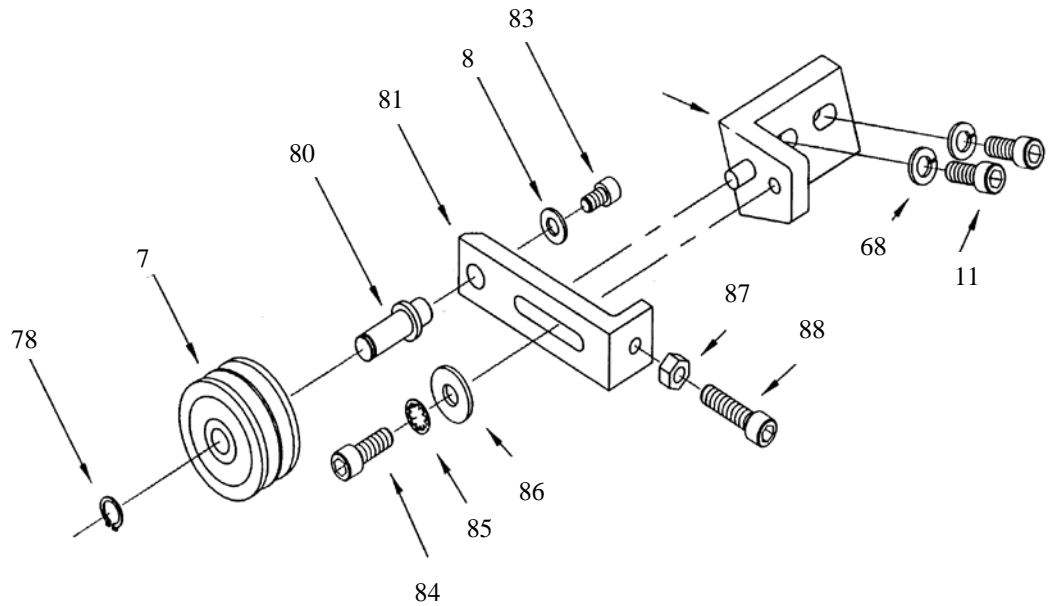

Figure 6.16 - Idler Pulley Assembly

REF #	PART #	DESCRIPTION	QTY
	HL1101-A41	IDLER PULLEY ASSEMBLY, INCLUDES REF # 78 - 88	ASSEMBLY
78	HL1101-264	LOCK RING	1
79	HL1101-4033	IDLER PULLEY	1
80	HL1101-4036	IDLER PULLEY SHAFT	2
81	HL1101-4039	IDLER PULLEY ARM	1
82	HL1101-147	WASHER FLAT 5/16	6
83	HL1101-145	SCREW SOCKET HD 5/16 -18 X 1/2	1
84	HL1101-214	SCREW SOCKET HD 3/8-16 X 11/4	1
85	HL1101-246	WASHER	2
86	HL1101-298	WASHER FLAT 3/8	2
87	HL1101-247	NUT 3/8-16	4
88	HL1101-228	SCREW SOCKET HD 3/8-16 X 1. 1/2	4

Table-6.7-Idler Pulley Assembly Description

Table 6.8 - Control Cabinet Assembly Description

REF #	PART #	DESCRIPTION	QTY
89	HL1101-A16	TRANSFORMER CABINET ASSEMBLY COMPLETE	1
90	HL1101-A65	FUSE HOLDER COMPLETE	1
91	HL1101-A71	GROUND CABLE ASSEMBLY	1
92	HL1101-126	GROMMET	1
93	HL1101-20	POWER TRANSFORMER	1
94	HL1101-44	POWER CONTACTOR RELAY	1
95	HL1101-45	FUSE 3AG TYPE 3A, 250 V	1
96	HL1101-2929STD	PLUG 9 PIN	1
97	HL1101-2929REV	PLUG 4 PIN	1
98	HL1101-2930REV	POWER PLUG 3 SOCKET	1
99	HL1101-2930STD	POWER PLUG 3 PIN	1
100	HL1101-3039	CABINET COVER	1
101	HL1101-3037	CABINET	1
102	HL1101-150	SCREW	2
103	HL1101-241	WASHER	2
104	HL1101-259	NUT	15

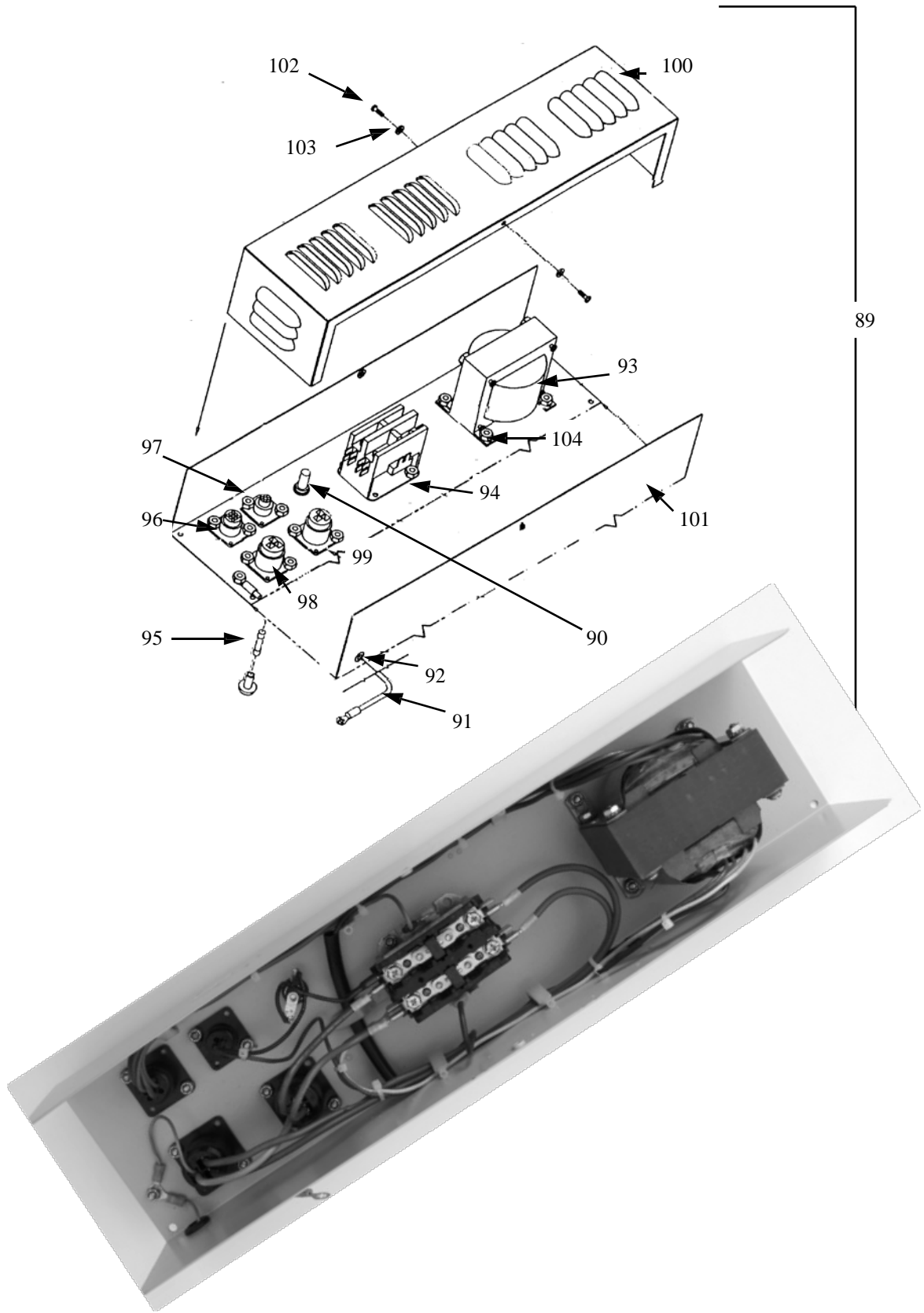

Figure 6.17 - Control Cabinet Assembly

Figure 6.18 - Main Frame Assembly

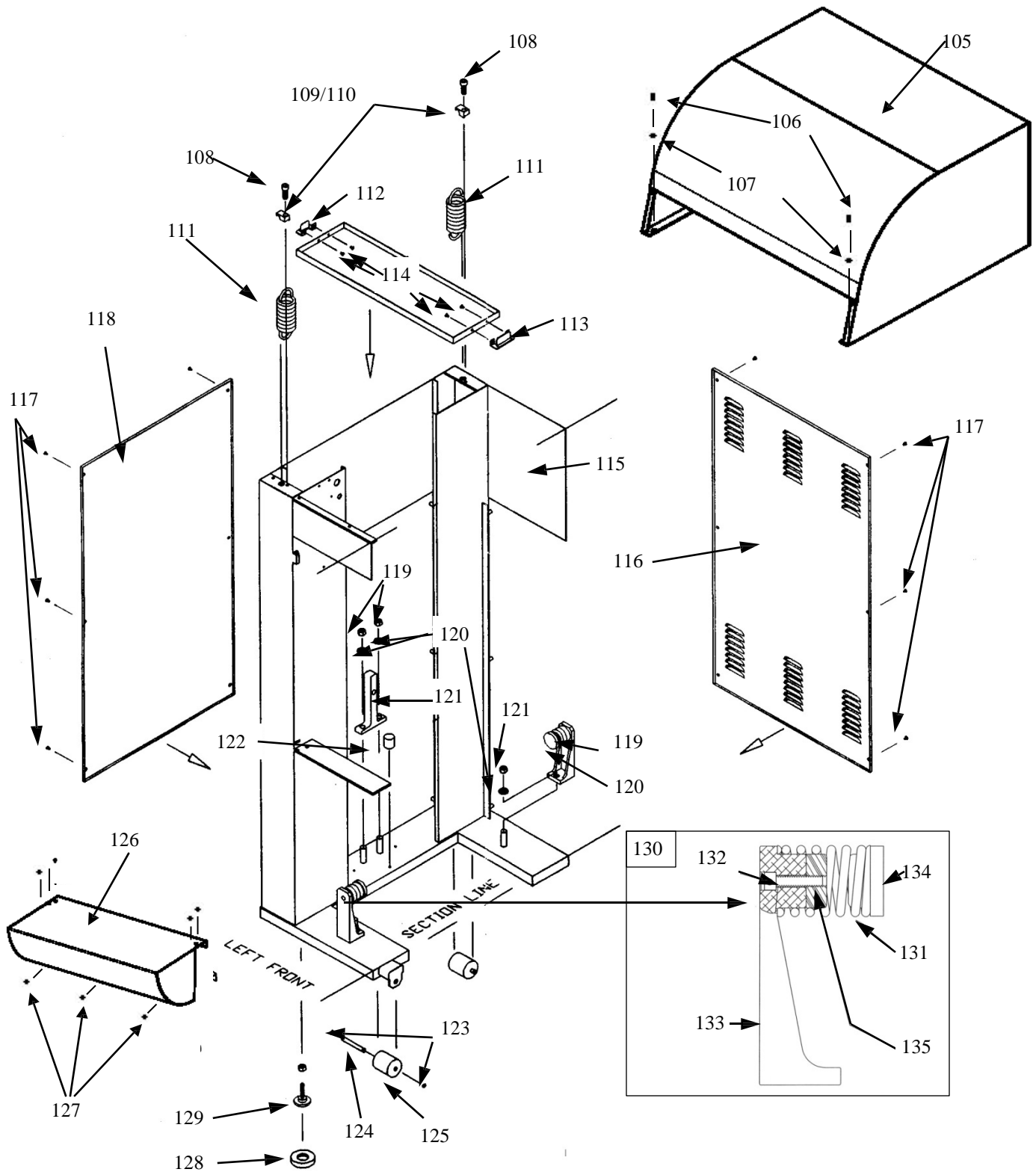

Table 6.9 - Main Frame Assembly Description

REF #	PART #	DESCRIPTION	QTY
105	HL1101-A7	HOOD	1
106	HL1101-239	BOLT 1/4-20 X 1/2	2
107	HL1101-241	WASHER	2
108	HL1101-282	SCREW SOCKET HEAD 1/4-20 X 3/4	1
109	HL1101-209	SPRING HOLD DOWN RIGHT	1
110	HL1101-210	SPRING HOLD DOWN LEFT	1
111	HL1101-4046	SUSPENTION SPRING	4
112	HL1101-A24	PLUG BRACKET 6	1
113	HL1101-A23	PLUG BRACKET 14	1
114	HL1101-150	SCREW	4
115	HL1101-A4	MAIN FRAME	1
116	HL1101-A36	REAR PANEL	1
117	HL1101-252	SCREW 10-32 X1/4	24
118	HL1101-A31	SIDE PANEL	2
119	HL1101-216	NUT 3/8	4
120	HL1101-246	WASHER 3/8	4
121	HL1101-4031	BRACKET SHIPPING	2
122	HL1101-232	VIBRATION MOUNT	2
123	HL1101-304	E RING 5/16	6
124	HL1101-1011	PIN	3
125	HL1101-1014	WHEEL	3
126	HL1101-A27	CAN SHELF ASSEMBLY OUTSIDE	1
127	HL1101-252	SCREW 10-32 X 1/4	5
128	HL1101-1013	FOOT PAD	2
129	HL1101-A30	ADJUSTABLE FOOT	4
130	HL1101-A9	DAMPENING SPRING BRACKET ASSEMBLY	4
131	HL1101-238	COMPRESSION SPRING	4
132	HL1101-299	CAPSCREW ,SOCKET HEX HEAD, 1/4-20 X 1	4
133	HL1101-2020	DAMPENING BRACKET	4
134	HL1101-3015	DAMPENING SPRING PAD	4
135	HL1101-3016	DAMPENING BRACKET SPRING GUIDE	4

Figure 6.19 - Front Panel And Wiring

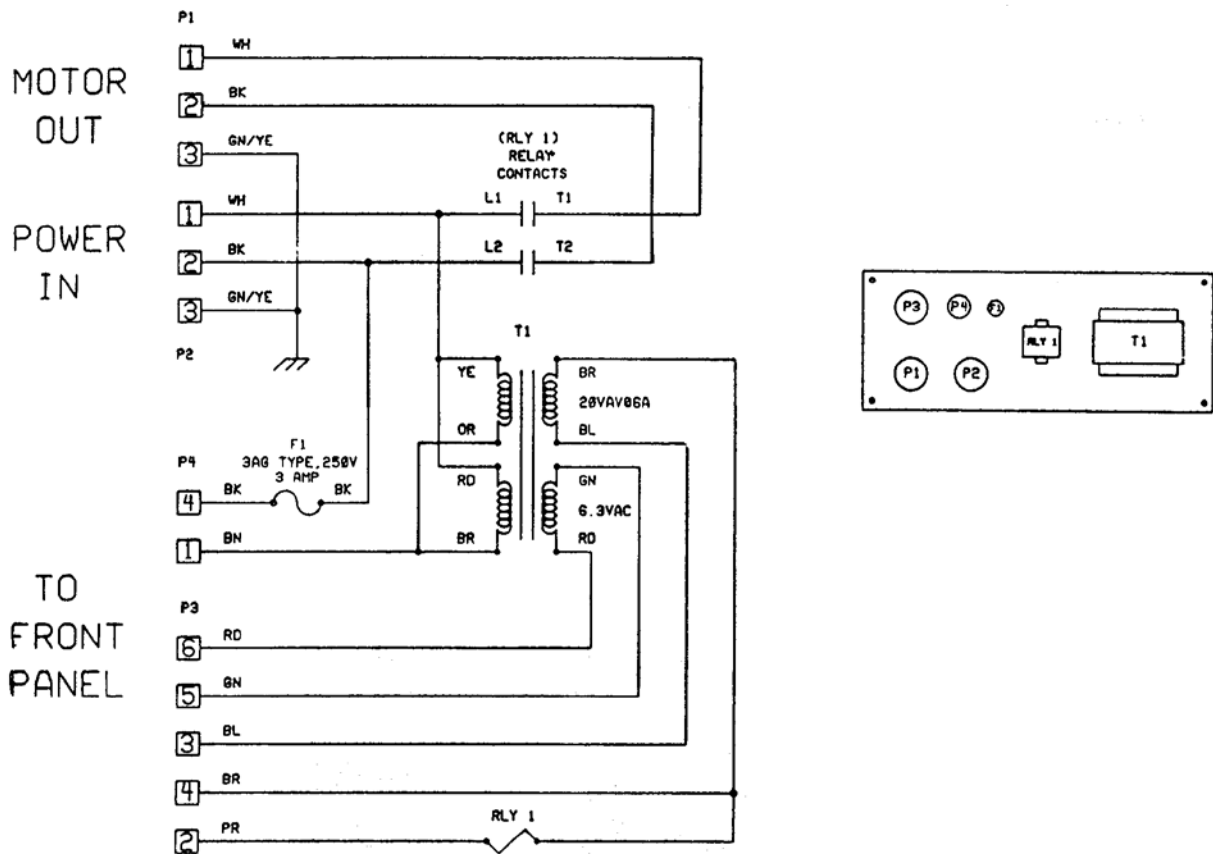
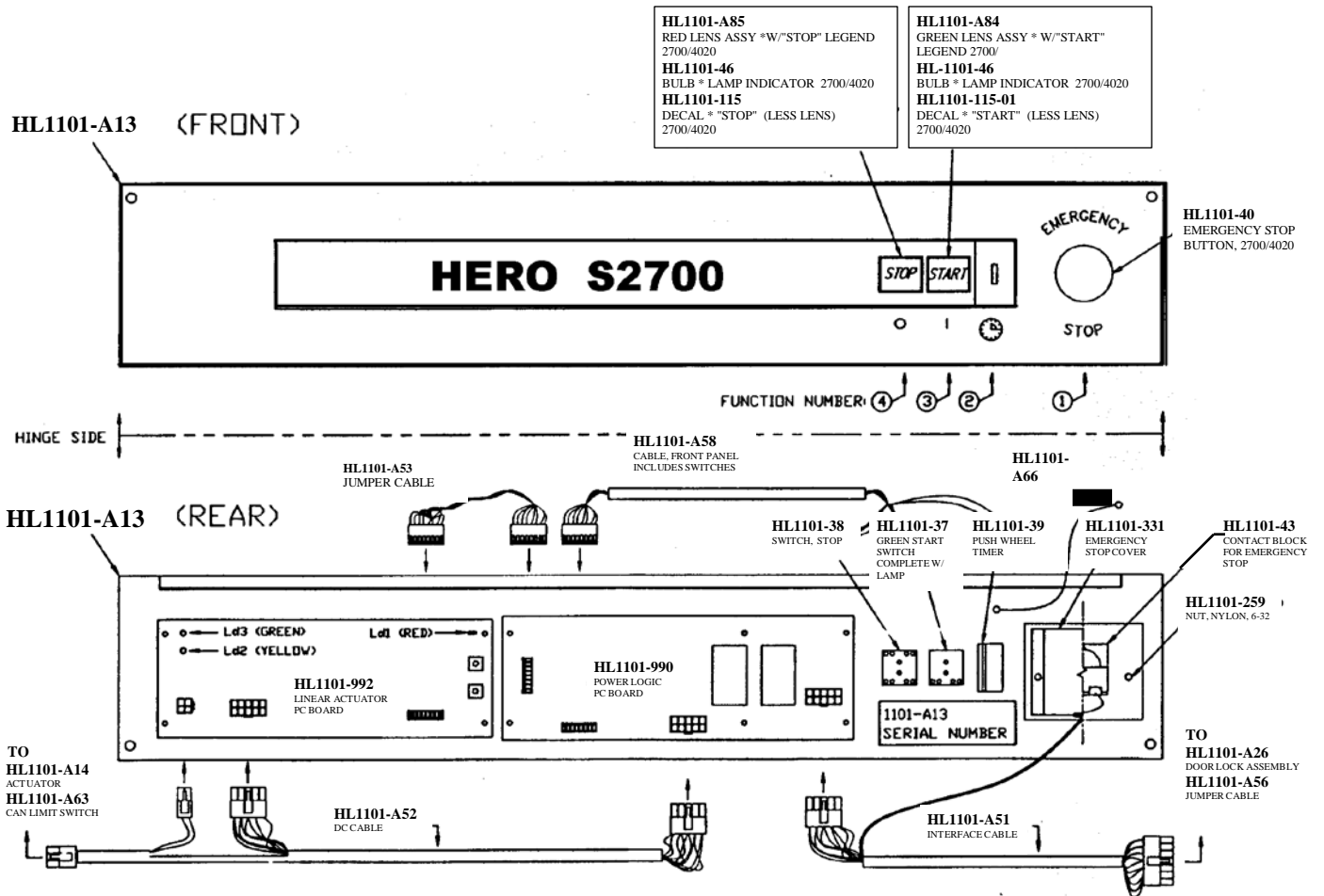
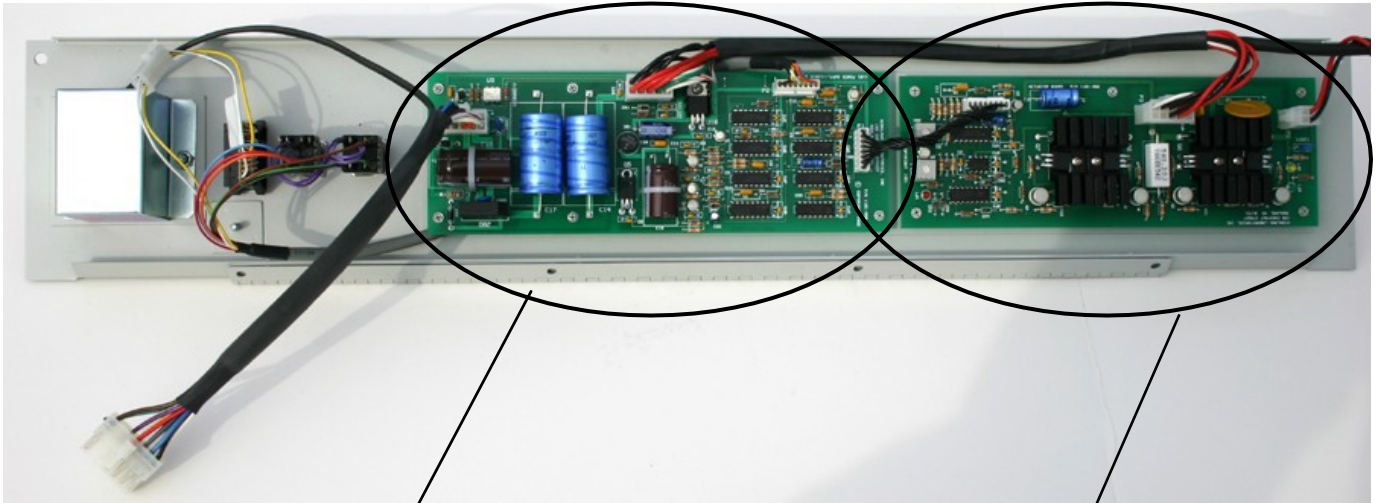
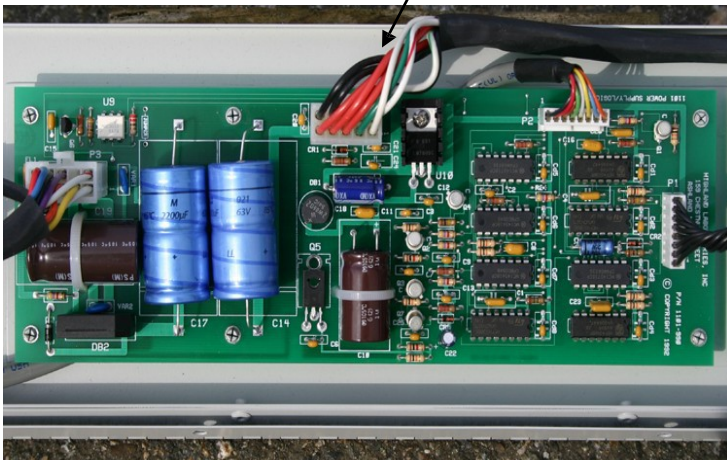

Figure 6.20 - Control Board



Control Board Close-ups



POWER LOGIC PCB

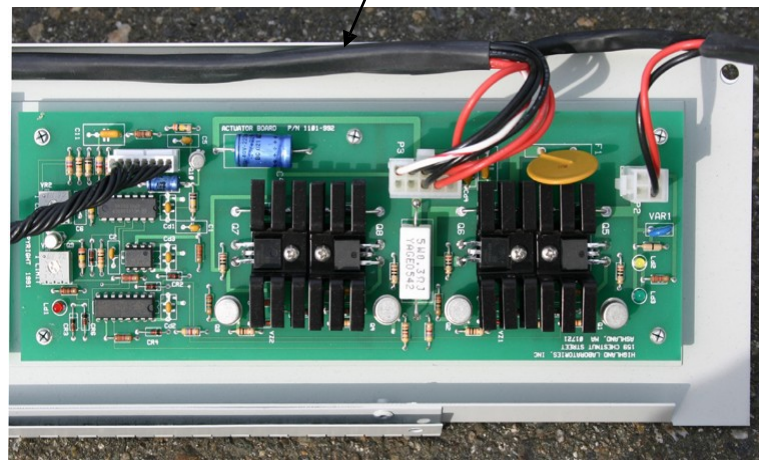

LINEAR ACTUATOR PCB



Figure 6.21 - Wiring Diagram

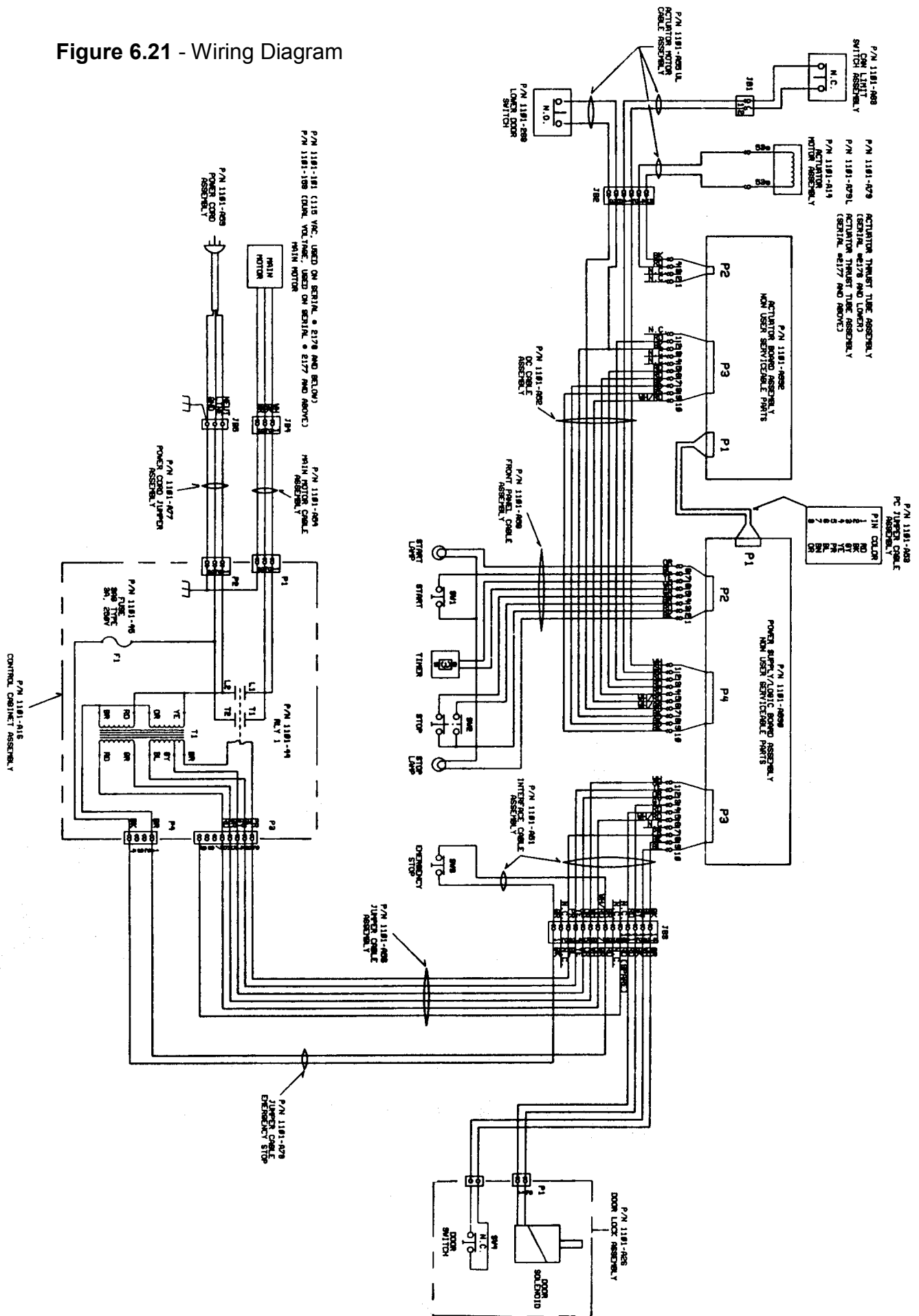

7. COMPLETE PARTS LIST

REF #	PART #	DESCRIPTION	QTY
1	HL1101-A14L	ACTUATOR COMPLETE	1
2	HL1101-A45	ACTUATOR MOTOR CLAMP ASSEMBLY	1
3	HL1101-282	SCREW	2
4	HL1101-138	CABLE TIE	1
5	HL1101-A55UL	ACTUATOR CABLE ASSEMBLY	1
6	HL1101-A10	ACTUATOR GROUND CLAMP	1
7	HL1101-A44	ACTUATOR TUBE CLAMP ASSEMBLY	1
8	HL1101-237	PRESSURE PLATE BUMPER SPACER	2
9	HL1101-232	PRESSURE PLATE BUMPER	2
10	HL1101-A28	PRESSURE PLATE ASSEMBLY COMPLETE	1
11	HL1101-213	SCREW SOCKET HEAD 3/8 X 1"	1
12	HL1101-272	WASHER 3/8"	1
13	HL1101-126	GROMMET	1
14	HL1101-223	CLAMP 1/4"	2
15	HL1101-136	WASHER	4
16	HL1101-256	WASHER LOCK #6	5
17	HL1101-266	SCREW 6-32 X 5/16	2
18	HL1101-A63	CAN LIMIT SWITCH ASSEMBLY	1
19	HL1101-265	SCREW	2
20	HL1101-A81	ACTUATOR MOTOR ASSEMBLY	1
21	HL1101-A79	ACTUATOR TUBE ASSEMBLY, BEFORE S/N 2177	
	HL1101-A79L	ACTUATOR TUBE ASSEMBLY, AFTER S/N 2177	1
22	HL1101-118	RUBBER PAD (PRESSURE PLATE)	1
23	HL1101-3025	PRESSURE PLATE SIDE GUIDES	2
24	HL1101-144	SCREW 10-32 X 3/8", (NOT AVAILABLE) SEE REF # 25A	2
25	HL1101-3034	PRESSURE PLATE TANG SPRINGS, (NOT AVAILABLE) SEE REF # 25A	2
25A	HL1101-3032	PRESSURE PLATE SLEEVE KIT (REPLACES REF # 24 & 25)	KIT
26	HL1101-3033	PRESSURE PLATE (METAL ONLY)	1
27	HL1101-A29	CAN SHELF (METAL ONLY)	1
28	HL1101-102	FLANGE BEARING C/W HL1101-109	2
29	HL1101-109	COLLAR FLANGE BEARING	1
30	HL1101-281	GREASE NIPPLE	1
31	HL1101-246	WASHER	4
32	HL1101-248	NUT (NYLOCK) 3/8-16	4
33	HL1101-110	TORX CAP SREW 8-32 X 5/8	2
34	HL1101-A8	CONTROL ARM COMPLETE	2
35	HL1101-A50	QUART ADAPTOR	1
35B	HL1101-234	CAN PAD, 1/2"	ACCESSORY
35C	HL1101-235	CAN PAD, 3/4"	ACCESSORY

Table 7.10 - Can Shelf Assembly Description

REF #	PART #	DESCRIPTION	QTY
41	HL1101-A15	DOOR COMPLETE	1
42	HL1101-3008	DOOR PLEXIGLSS ONLY	1
43	HL1101-A20	UPPER DOOR HINGE	2
44	HL1101-4009	PLATE	1
45	HL1101-A21	LOWER DOOR HINGE	1
46	HL1101-276	SCREW	1
47	HL1101-259	NUT	2
48	HL1101-269	WASHER	2
49	HL1101-254	SCREW	2
49A	HL1101-4014	DOOR LOCK SHIELD	1
50	HL1101-3053	LEVER	1
51	HL1101-141	E-RING	1
52	HL1101-4051	SPRING	1
53	HL1101-268	DOOR LOCK SWITCH	1
54	HL1101-151	SCREW 4-40-X-1/2	2
55	HL1101-329	INSULATING PAPER	4
56	HL1101-112	SOLENOID	5
57	HL1101-300	SOLENOID BUMPER	2
58	HL1101-301	SCREW 4-40 X 3/16	1
59	HL1101-4063	DOOR LOCK LINK	2
60	HL1101-150	SCREW 6-32 X 3/8	1
61	HL1101-A33	PLUNGER ASSEMBLY	1
62	HL1101-111	SPRING	1
63	HL1101-A26	DOOR LOCK ASSEMBLY COMPLETE	1

Table 7.11 - Door & Door Lock Assembly

REF #	PART #	DESCRIPTION	QTY
	HL1101-A41	IDLER PULLEY ASSEMBLY, INCLUDES REF # 78 - 88	ASSEMBLY
78	HL1101-264	LOCK RING	1
79	HL1101-4033	IDLER PULLEY	1
80	HL1101-4036	IDLER PULLEY SHAFT	2
81	HL1101-4039	IDLER PULLEY ARM	1
82	HL1101-147	WASHER FLAT 5/16	6
83	HL1101-145	SCREW SOCKET HD 5/16 -18 X 1/2	1
84	HL1101-214	SCREW SOCKET HD 3/8-16 X 11/4	1
85	HL1101-246	WASHER	2
86	HL1101-298	WASHER FLAT 3/8	2
87	HL1101-247	NUT 3/8-16	4
88	HL1101-228	SCREW SOCKET HD 3/8-16 X 1. 1/2	4

Table 7.12 - Idler Pulley Assembly

REF #	PART #	DESCRIPTION	QTY
	HL1101-A40	MOTOR BRIGE ASSEMBLY C-FACE & COUNTER WEIGHT ASSEMBLY, 110V	ASSEMBLY
64	HL1101-A82	MOTOR BRIGE ASSEMBLY C-FACE , AFTER # 2177	1
	HL1101-A5	MOTOR BRIDGE ASSEMBLY, BEFORE SERIAL # 2177	1
65	HL1101-A61	CRANKSHAFT /COUNTERWEIGHT ASSEMBLY	1
66	HL1101-159	MOTOR, 3/4 HP, 110V (SERIAL # 2177 AND HIGHER)	2
	HL1101-101	MOTOR, 110V, (SERIAL # 2176 AND LOWER)	1
67	HL1101-309	MOTOR CAPACITOR	1
68	HL1101-272	WASHER SPLIT 3/8	6
69	HL1101-212	SCREW SOCKET HD 3/8-16 X 3/4	1
70	HL1101-A41	IDLER BRAKET ASSEMBLY	1
71	HL1101-104	V BELT (EACH)	2
72	HL1101-103	BEARING	2
73	HL1101-249	SCREW SOCKET HD 3/8-16 X 1. 1/2	4
74	HL1101-250	WASHER FLAT 1/2	4
75	HL1101-251	WASHER SPLIT 1/2	1
76	HL1101-213	SCREW SOCKET HD 3/8-16 X 1	1
77	HL1101-4040	MOTOR PULLEY, 110 V	1
	HL1101-135	MOTOR PULLEY, 220 V	1
77A	HL1101-310	MOTOR PULLEY SET SCREW, 1/4-20 X 1/4'	1

Table 7.13 - Crankshaft Assembly Description

REF #	PART #	DESCRIPTION	QTY
89	HL1101-A16	TRANSFORMER CABINET ASSEMBLY COMPLETE	1
90	HL1101-A65	FUSE HOLDER COMPLETE	1
91	HL1101-A71	GROUND CABLE ASSEMBLY	1
92	HL1101-126	GROMMET	1
93	HL1101-20	POWER TRANSFORMER	1
94	HL1101-44	POWER CONTACTOR RELAY	1
95	HL1101-45	FUSE 3AG TYPE 3A, 250 V	1
96	HL1101-2929STD	PLUG 9 PIN	1
97	HL1101-2929REV	PLUG 4 PIN	1
98	HL1101-2930REV	POWER PLUG 3 SOCKET	1
99	HL1101-2930STD	POWER PLUG 3 PIN	1
100	HL1101-3039	CABINET COVER	1
101	HL1101-3037	CABINET	1
102	HL1101-150	SCREW	2
103	HL1101-241	WASHER	2
104	HL1101-259	NUT	15

Table 7.14 - Control Cabinet Assembly Description

Table 7.15 - Main Frame Assembly Description

REF #	PART #	DESCRIPTION	QTY
105	HL1101-A7	HOOD	1
106	HL1101-239	BOLT 1/4-20 X 1/2	2
107	HL1101-241	WASHER	2
108	HL1101-282	SCREW SOCKET HEAD 1/4-20 X 3/4	1
109	HL1101-209	SPRING HOLD DOWN RIGHT	1
110	HL1101-210	SPRING HOLD DOWN LEFT	1
111	HL1101-4046	SUSPENTION SPRING	1
112	HL1101-A24	PLUG BRACKET 6	1
113	HL1101-A23	PLUG BRACKET 14	1
114	HL1101-150	SCREW	4
115	HL1101-A4	MAIN FRAME	1
116	HL1101-A36	REAR PANEL	1
117	HL1101-252	SCREW 10-32 X1/4	24
118	HL1101-A31	SIDE PANEL	2
119	HL1101-216	NUT 3/8	4
120	HL1101-246	WASHER 3/8	4
121	HL1101-4031	BRACKET SHIPPING	2
122	HL1101-232	VIBRATION MOUNT	2
123	HL1101-304	E RING 5/16	6
124	HL1101-1011	PIN	3
125	HL1101-1014	WHEEL	3
126	HL1101-A27	CAN SHELF ASSEMBLY OUTSIDE	1
127	HL1101-252	SCREW 10-32 X 1/4	5
128	HL1101-1013	FOOT PAD	2
129	HL1101-A30	ADJUSTABLE FOOT	4
130	HL1101-A9	DAMPENING SPRING BRACKET ASSEMBLY	4
131	HL1101-238	COMPRESSION SPRING	4
132	HL1101-299	CAPSCREW , SOCKET HEX HEAD, 1/4-20 X 1	4
133	HL1101-2020	DAMPENING BRACKET	4
134	HL1101-3015	DAMPENING SPRING PAD	4
135	HL1101-3016	DAMPENING BRACKET SPRING GUIDE	4

8. PREPARING SHAKER FOR SHIPPING

1. Remove side panels (See 5.1 page 12).
2. Secure the shake frame to the outer frame: Using a 9/16" socket wrench, bolt the two hex head cap screws, one on each side of the shake frame located at the bottom center of the shaker. These cap screws secure the shake frame to the outer frame base. These cap screws were provided with the original shipment and were to be kept in case the unit was to be moved to another location. They were identified by red paint markings. (See Figure 8.1 for installation locations.)

Shake frame securing cap screw
HW10847P - 3/8NC 1.5" Hex bolt
HW5063P - 3/8" Lock Washer
HW50545P - 3/8" Flat washer

Figure 8.1
Bottom shipping
bracket and frame
securing hex bolt

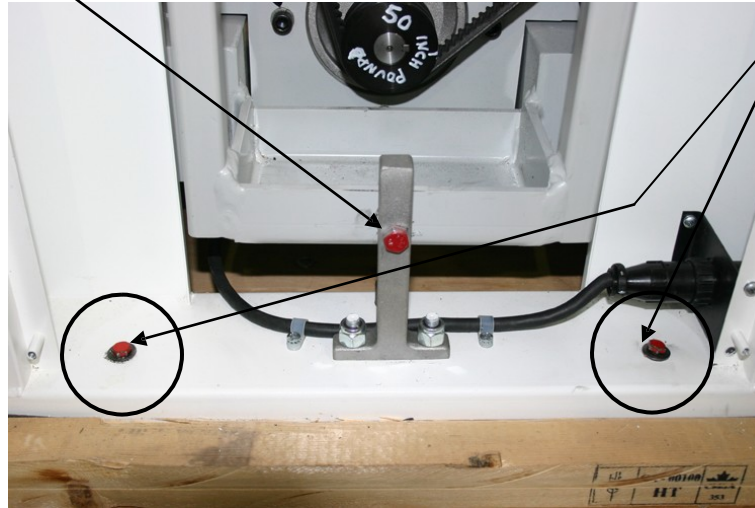

Four 1/4" x 4" Lag bolts
and washers can be
used to secure bottom of
shaker to skid
HW30696P - 4" Lag bolts
HW5050P - flat washers 5/16"

3. If shipping on a standard wooden skid. Secure the bottom of the shaker to the skid with four 1/4" x 4" lag bolts (HW30696P).

4. Re- Install Upper shipping brackets: Use the four 3/4" cap screws and lock washers to secure the red metal shipping brackets in place.

HL1101-4054 - Set of 2 Red metal shipping brackets
HW10832P - 3/8NC x 3/4" Hex bolt
HW5063P - 3/8" Washers

Location of shipping braces are on top side-to-side of
can shelf assembly. (See Figure 8.2)

**Note: ALWAYS save these hex head cap screws,
washers and brackets in case the shaker is
shipped to another location or returned for ser-
vice.**

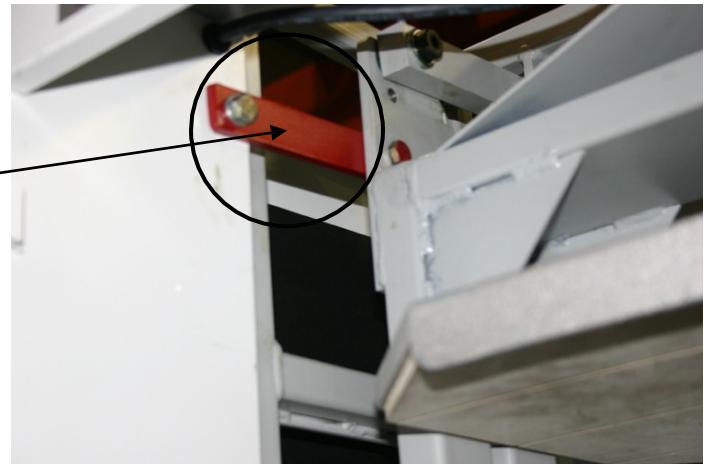

Figure 8.2 - Upper Shipping Bracket

NOTE: If you can not locate shipping bolts and braces please contact HERO Customer service at TOLL FREE 800-494-4376 to order these. If your shaker is not shipped with these brackets and bolts in place, damage may occur.

8. PREPARING SHAKER FOR SHIPPING

Unplug the Control Boards: It is recommended to unplug the control board before shipping so that the unit is not operable at the new location with shipping bolts and braces still installed.

1. Using a Phillips screwdriver, remove the two screws that secure the electronic panel to the top cover. Swing the electronic panel forward. (Figure 8.3)



Figure 8.3—Electronic panel

Control Board Plug

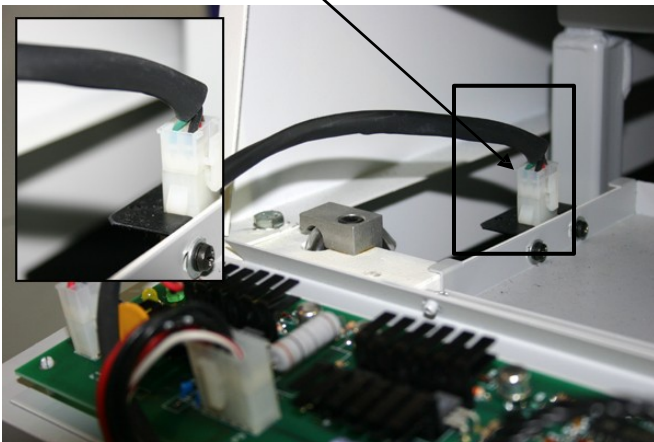

Control Board Plug

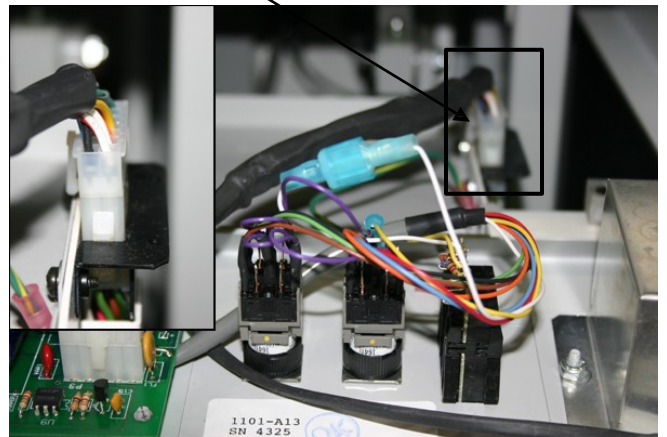

Figure 8.4—Control board plugs

2. With printed circuit boards facing up, un-plug the two control board plugs from their respective housings. See figure 8.4
3. Swing the electronic panel back toward the top cover.
4. Holding the electronic panel in place, replace the two (2) screws (with lock washers).

MODEL: **S2700 Mega-Mix™**

Serial number: _____

INSTALLATION DATE: _____

DATE	MAINTENANCE DESCRIPTION

Model: S2700 Mega Mix™ Paint Mixer Warranty & Claim Procedures

I.C.T.C. Holdings is proud to offer an industry leading "Two Year Parts Warranty" and -One Year Labor Warrantyll on all of its H.E.R.O. Shakers and Mixers

I.C.T.C. warrants it's paint mixer to be free of materials defects, to the original user, for a period of Two (2) Years. This warranty entitles the owner to parts replacement at no charge. The parts warranty is valid for any necessary replacement, whether caused by material, workmanship defect or simple wear, except as noted below.

Electric motors, timers and pneumatic motors warranted for twelve (12) months only.

The warranty is applicable to the original owner only and is non-transferable. The equipment must be , operated and maintained in accordance with all instructions, precautions and warnings contained in the owner's manual. For the purpose of this warranty, damage caused by accident, abuse, improper cleaning or lack thereof, or improper operation, is not covered. Cleaning and general maintenance is the responsibility of the owner / operator and is not covered by the warranty.

I.C.T.C.'s liability is limited to the replacement of parts found to be defective or worn and does not include damage or other expenses of any kind incurred in connection with the purchase and use of the dispenser.

All parts required for warranty service are invoiced to the client, with credit provided upon submission of a valid warranty claim. A valid claim lists model number, serial number, date of installation, lists all parts used and provides provisions for parts installation labor charges.

Major parts replacement may require the return of defective parts. If uncertain, call for further instructions. All returns must be authorized and no return will be accepted without a Return Goods Authorization (RGA) number.

I.C.T.C. Holdings Corporation
HERO Products Group

720 Eaton Way

Delta, B.C. Canada V3M 6J9

USA Correspondence:

P.O. Box 75 Custer, WA

98240-0075

Phone Toll Free: 1-800-494-4376 or

Phone: 604-522-6543 Fax: 604-522-8735

Website: www.hero.ca

Emails: sales@hero.ca or customercare@hero.ca

HERO
INNOVATIVE COLOR TECHNOLOGY