

HERO

INNOVATIVE COLOR TECHNOLOGY

One Gallon Multi Mix™ Paint Mixer

S2425
COUNTERTOP

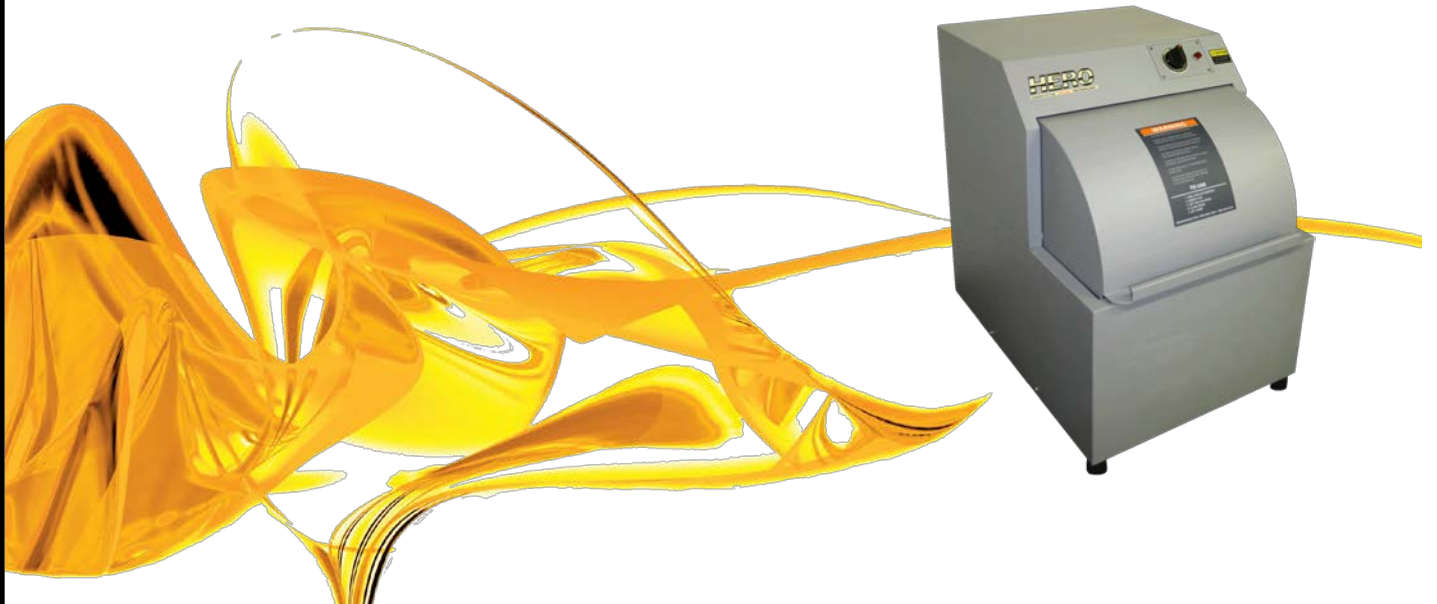

MANUAL

PARTS LIST



**WARNING: DO NOT OPERATE THIS EQUIPMENT WITHOUT READING
AND UNDERSTANDING ALL SAFETY AND OPERATING INSTRUCTIONS**

Table of Contents

Receiving	3
Precautions and General Information	3
Preparation for Operation	4
Electrical Connection	5
Operation	6
Maintenance	7
Gear Drive Assembly - Main Drive	8
Gear Drive Assembly - Canister Drive	9
Cradle Assembly	10-11
Timer	12-13
S2425 Series Shaker Stands	14
Parts Diagram	15
Parts List	16

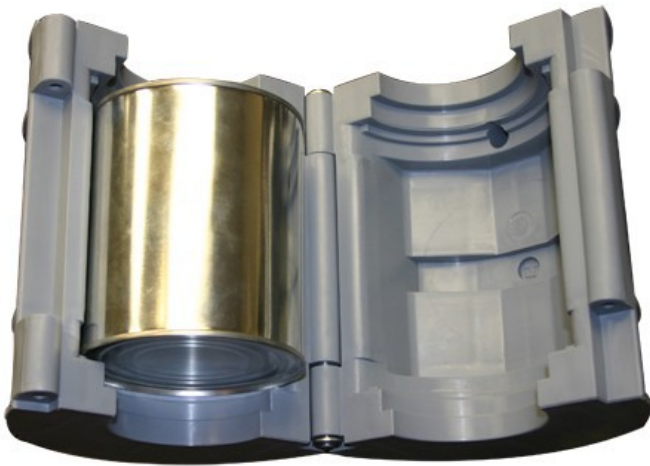

Quart/ Liter Adapter:
included with each mixer
Part# HL350-A11

Also Available:

Optional Pint / 1/2 Pint adapter to fit
inside above Quart/Liter adapter
Part # HL350-A26

Or complete kit with above HL350-A11
Qt/Lt adapter as well as HL350-A26 Pint
1/2 pint adapter
Part# HL350-A27

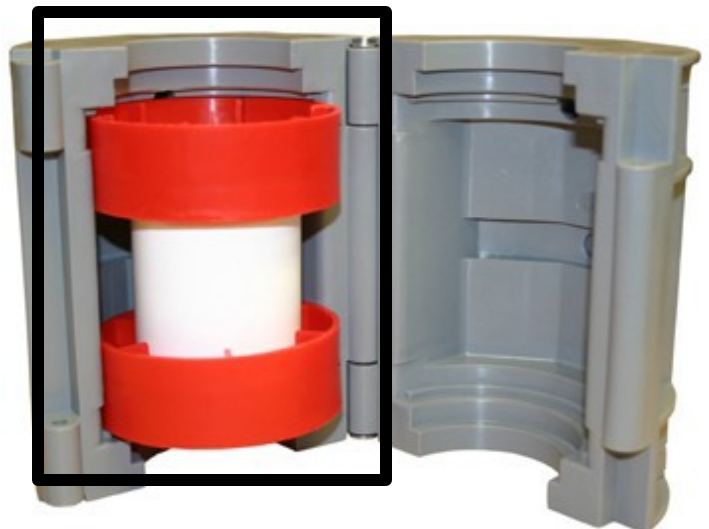

RECEIVING

VISUALLY INSPECT your new S2425 Dual Axis™ Multi-Mix™ for damage that may have been caused by shipping. If there is any visible damage to the carton, have carrier acknowledge by signing and noting the damage on the Bill of Lading. Proceed to file a claim with the delivering carrier.

UNPACK MIXER by cutting the metal strapping and lifting the box straight up from the wooden shipping tray. Remove mixer from tray. The crate is custom fitted for the mixer so there are no bolts to remove.

INSPECT MIXER for concealed damage. Should any damage be noted, a Hidden Damage Report must be filed by the consignee with the delivery carrier. Do not delay in filing the report form.

PRECAUTIONS AND INFORMATION



THIS MACHINE IS NOT EXPLOSION PROOF.

MIXING OR CLEANING WITH A FLAMMABLE SUBSTANCE COULD CAUSE AN EXPLOSION.

IN THE EVENT OF SPILLAGE CONSULT PAINT CAN SPILL CLEAN UP SECTION.

ALWAYS make sure the LID to any cans being mixed are on TIGHT before putting them into the MIXER.

The Mixer is designed to operate only if the cover is closed. DO NOT attempt to alter the electrical interlock of the timer and cover.

REPAIR IMMEDIATELY a failure of the cover interlock system to avoid injury from improper operation. Contact HERO Products Group or a local licensed electrician.

The electric motor is equipped with an AUTOMATIC THERMAL OVERLOAD device. Should the motor stop running due to an overload, it will automatically reset itself when the motor returns to normal operating temperature.

THE TIMER turns the Mixer ON and OFF. The paint container can be removed before completion of the timer cycle by slowly opening the mixer door. The mixer shuts off after opening the door 1 to 2 inches. It is then safe to open the door fully and remove the can. DO NOT open the door if the Mixer does not stop.

Forcing the timer back to the zero position will cause premature failure of the mechanical timer.

When not in use for extended periods of time, ensure that the machine, including its power cord, is stored in a way that it is protected from damage.

PREPARATION FOR OPERATION

Loading:

The four mixer leveling feet have been adjusted at the factory to level the mixer and distribute the weight of the machine equally on all four feet. This procedure will need to be done again once the mixer is setup in its final operating location as all floors vary.



Proper loading is achieved by screwing any one of the four feet until there is no clearance between the foot and floor. Then, while applying light hand pressure to the other three feet, screw the fourth foot against the floor and re-tighten locknut. Be careful not to raise the other Mixer feet off the floor when tightening the fourth foot against the floor. With the mixer feet properly loaded, a single sheet of paper will NOT easily slide between the foot and the floor.

Leveling:

The level of a mixer can be checked by putting a level on top of the cabinet and adjusting any of the four feet to center the level bubble. Leveling the mixer is not usually required, but should be checked during the above loading procedure.

If your mixer is properly Loaded and Leveled, it should not “walk” or vibrate during operation. If the mixer does vibrate or “walk”, check and readjust mixer level and foot loading.

Lift the cover and remove the quart/Liter adapter from the can holder.

INSERT the drip/spillage tray underneath the mixer once the feet are properly adjusted and the machine runs smoothly.

Note: These mixers are designed to handle up to a eighteen pound can. General operation and vibration levels are checked up to these limits.

Optional Kit available to convert a Countertop mixer to Floorstand unit

In order to convert your Countertop mixer to a Floorstand the first step is to lay the mixer over on its side. Then remove the four feet on the bottom of the mixer. Attach the floorstand riser with the 4 bolts and lock washers that come with the Floorstand conversion kit into the same locations that the four feet were mounted. DO NOT remove the 3 nuts in the center of the bottom of the mixer that fasten the shake frame to the base. Re-Install the 4 feet along with the lock washers in the bolts holes at the bottom of the floorstand riser. The lock washers should be installed between the mixer and the foot lock nut. Set the mixer feet so there is a clearance of 1 3/4 inches between the mixer and the floor. Note the clearance at the bottom of the mixer will allow for the paint containment tray to slide underneath the mixer.

Upright the Mixer. Level and load the Mixer as described above. The reverse of this procedure can be done to change a Floorstand unit to a Countertop unit.

ELECTRICAL CONNECTION

Plug the mixer into a properly grounded outlet. Ensure the power cord is routed in a way that it is protected from damage.

Grounding Instructions:

- This product should be grounded. In the event of an electrical short circuit, grounding reduces the risk of electric shock by providing an escape wire for the electric current. This product is equipped with a cord having a grounding wire with an appropriate grounding plug. The plug must be plugged into an outlet that is properly installed and grounded in accordance with all local codes and ordinances.
- **WARNING** – Improper installation of the grounding plug can result in a risk of electric shock. When repair or replacement of the cord or plug is necessary, do not connect the grounding wire to either flat blade terminal. The wire with insulation having an outer surface that is green with or without yellow stripes is the grounding wire.
- Check with a qualified electrician or serviceman if the grounding instructions are not completely understood, or if in doubt as to whether the product is properly grounded. Do not modify the plug provided; if it will not fit into the outlet, have the proper outlet installed by a qualified electrician.
- This product is for use on a nominal 120-volt circuit, and has a grounding plug similar to the plug illustrated. Only connect the product to an outlet having the same configuration as the plug. Do not use an adapter with this product.

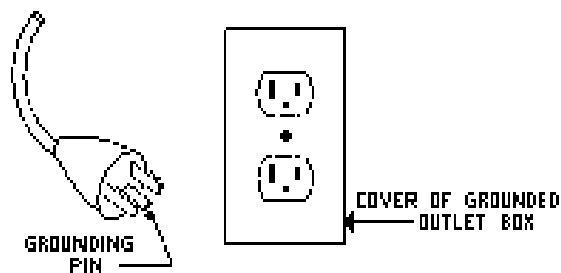

OPERATION

Steps to load and mix a can of paint:

1. Lift door of mixer up to access the can holder.
2. Rotate can holder towards the front of the mixer for ease of can insertion.
3. **Lid locks are an option on the model S2425** and are not required. If your unit is equipped with these rotate so they don't interfere with the insertion of the paint can or adapter. (See Open picture below) Note: Check paint can lid is secure before inserting into can holder.
4. Insert can into can holder with bail ears (if so equipped) slide into anti-rotation slots. This will also hold the bail handle into place straight up.
5. Rotate lid locks over can lid assuring they "lock" lid in place. Note: lid locks can be turned two ways see diagram below for correct locked position.
6. Close door of mixer and set timer to desired mixing time.

With the Mixer door closed, the timer will automatically start the mixer and shut off the mixer when the timed cycle is finished. Refer to precautions and Information on page 3 of the manual about opening the door during operation.

Use the included quart adapter to mix quarts, square quarts or colorant cans. Place the can into the adapter and operate the Mixer the same as with gallons (3.8 liter) cans.

NOTE: Should the Mixer vibrate excessively or "walk", re-check load and leveling as described on

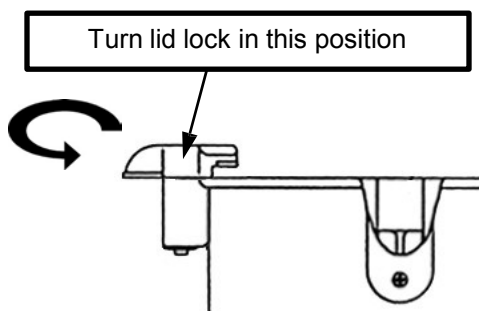

OPTIONAL LID LOCKS

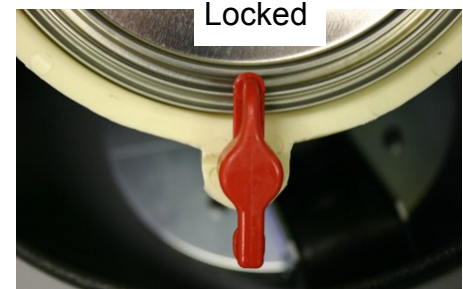
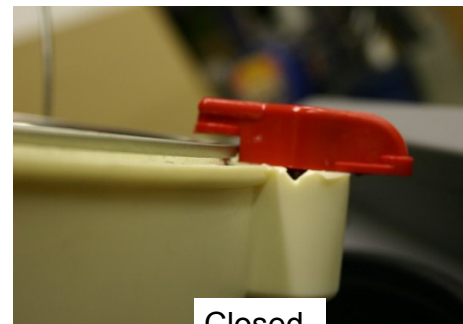
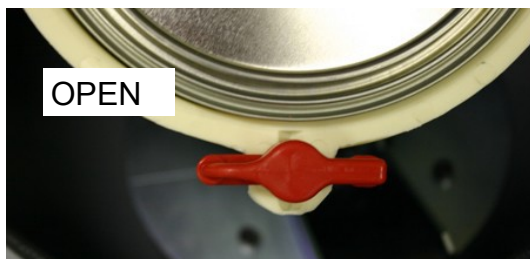

MAINTENANCE

UNPLUG the mixer before attempting to clean or service the machine.

CLEANING the mixer must only be done with nonflammable solvents such as soap and water. Never use flammable liquids such as gasoline to clean the mixer.

CAUTION: The use of solvents may cause damage to components of your mixer. For example the V-belt, bearings and motor. Please keep this in mind when considering any type of cleaning solution.

CHECK V-BELT drive tension every 6 months. Adjust the belt by loosening motor mount bolts and sliding the motor to achieve desired belt tension. Re-tighten motor mounting bolts. For new HERO V-belt order part# HL35021.

INSURE UNIT IS UNPLUGGED FROM POWER BEFORE PROCEEDING

ACCESS to the motor or belt for adjustment is gained by loosening the 7 screws located on the back of the unit. It is not necessary to completely remove the screws to separate the back from the main machine cabinet. Take care while lifting the panel so as not to pinch your fingers. The drive mechanism and motor are now accessible.

VISUALLY INSPECT wiring for signs of chaffing, rubbing or insulation breakdown anytime the mixer cabinet is removed. Correct any problems immediately.

ENSURE POWER CORD is routed in a way that it is protected from damage.

GEAR DRIVE ASSEMBLY— MAIN DRIVE

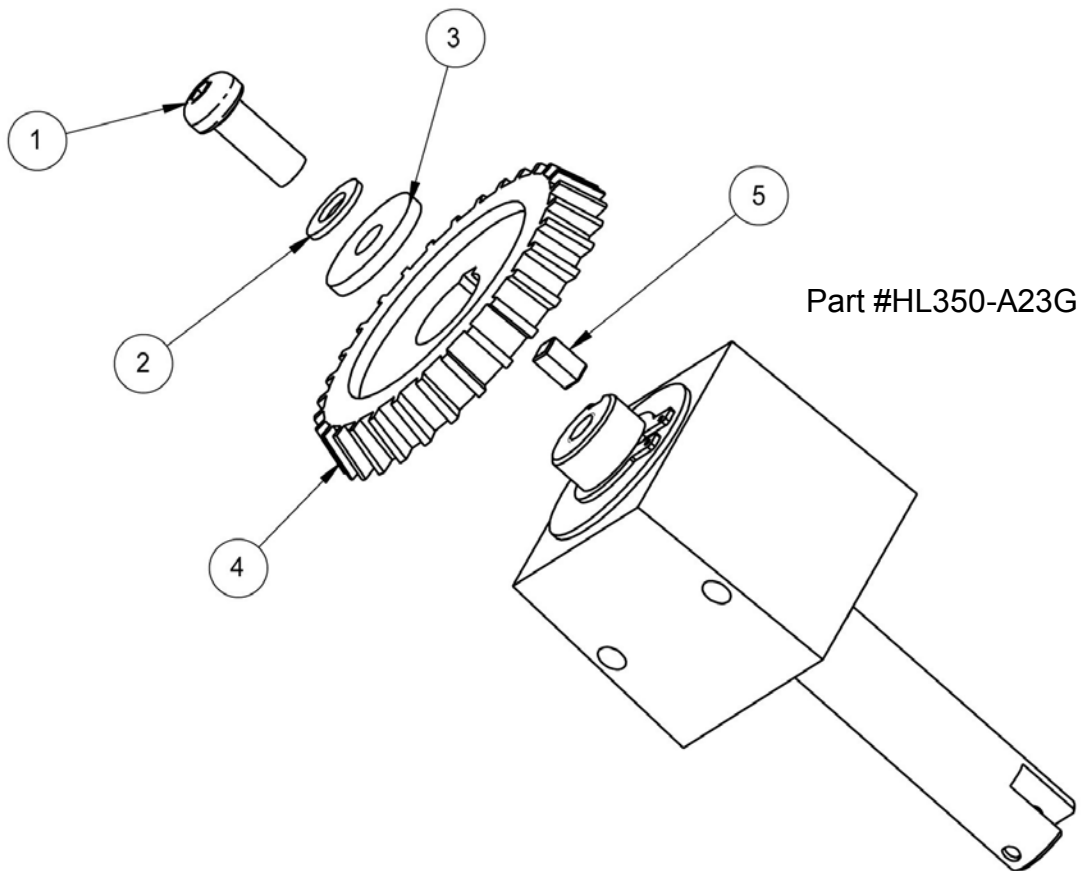

Part # HL350-A23G Gear Drive assembly Complete (Main Drive)

Includes the following:

Ref #	Part #	Qty	Description
1	HW3170P	1	SCREW * BUTTONHEAD 5/16NC X3/4 PLTD
2	HW50505P	1	WASHER * INTERNAL LOCK 5/16 PLTD
3	HW50535P	1	WASHER * FENDER 5/16 X 1 EXTRA HEAVY DUTY PLTD
4	HL350-228	1	GEAR * BEVEL MAIN 30T ALL S2450 SERIES MODELS/HS1000
5	HL350-245	1	KEY * 3/16 SQ MAIN GEAR ALL S2450 SERIES MODELS/HS1000

GEAR DRIVE ASSEMBLY— CANISTER DRIVE

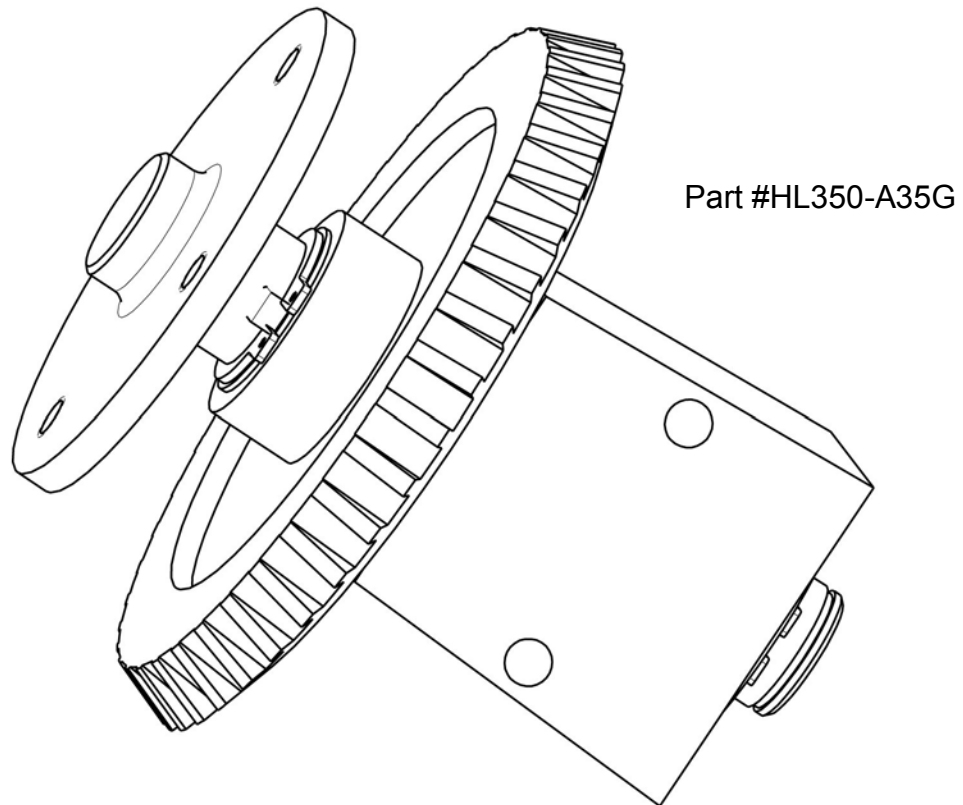

Part # HL350-A35G Gear Drive Assembly - Canister Drive

CRADLE ASSEMBLY



**Cradle Assembly
Complete
Part #HL350-A24G**

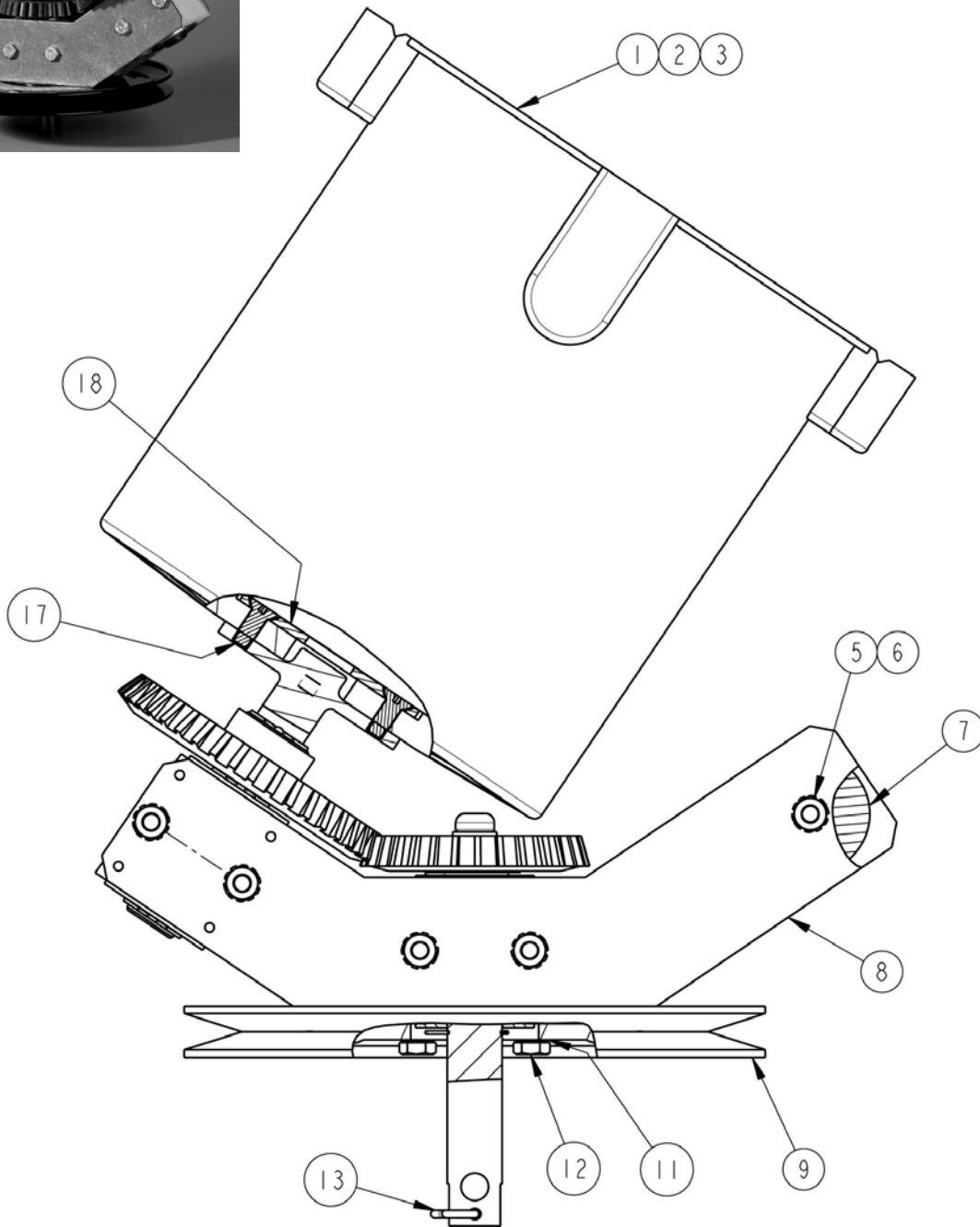

CRADLE ASSEMBLY

Part # HL350-A24G Cradle Assembly Complete (Gear Drive)

Includes the following:

Ref #	Part #	Qty	Description
1	HL3501	1	CANISTER ONLY * MACHINED P-PROPYLENE 12 MELT A.C. ALL S2400
2	HL350A20G	1	CANISTER ASSY & BEAR'G BLOCK AND DRV ASSY * ALL S2400/HS1000
3	HL350A23G	1	GEAR DRIVE ASSY * MAIN DRIVE 1045 AFT 02-01-08 S2450/HS1000
5	HW1047P	5	CAPSCREW * HEX HD 1/4NC X2-1/2 GR5 PLTD(WAS 442-650, 473-54)
6	HW4021P	5	NUT * KEP 1/4NC PLTD
7	HL350-26	1	COUNTERWEIGHT *1-5/8OD X2 (350-A28 ONLY) S2400 SERIES/HS1000
8	HL35024	2	CRADLE PLATE * (1 OF 2) ALL S2400 SERIES MODELS/HS1000
9	HL350A66	1	PULLEY ASSY * LARGE 8 IN ALL S2400 SERIES MODELS/HS1000
10	HL350A67	1	PULLEY & FLYWHEEL ASSY * ALL S2400 SERIES MODELS/HS1000
12	HW1020P	4	CAPSCREW * HEX HD 1/4NC X 3/4 GR5 PLTD (WAS 473-43)
13	HL350128	1	HAIRPIN * COTTER 1-15/16 IN LONG ALL S2400 MODELS/HS1000
17	HW10165	4	CAPSCREW * FLAT SKT HD 1/4NC X 5/8 (WAS 473-100)
18	HL350-30	1	DISC * CANISTER MOUNTING PLATE CNTRSUNK UPPER ALL S2400/HS1000

TIMER

6 MINUTE MECHANICAL TIMER

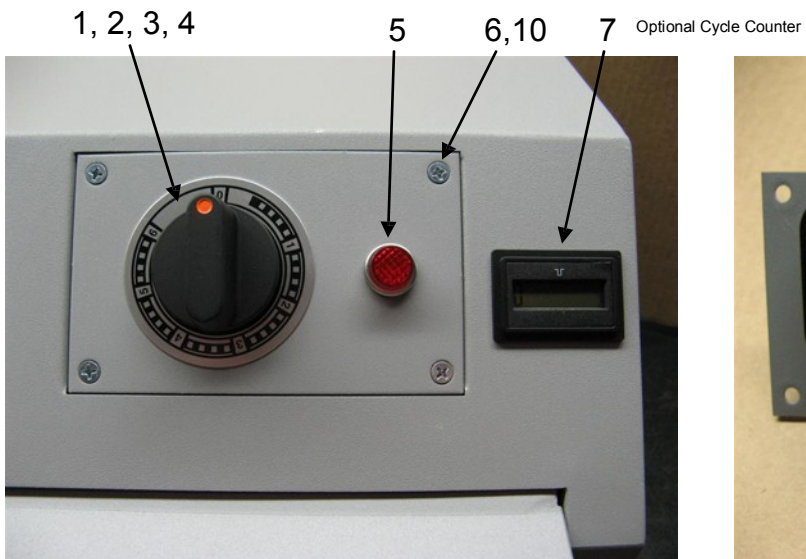

Mechanical Timer

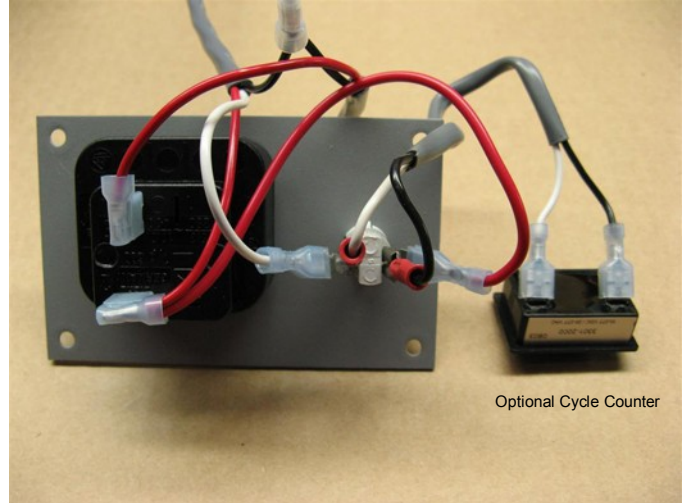

Back view of mechanical timer
110 Volt 60 hz wiring

TIMER

Ref #	Part #	Qty	Description
1	HL350A406M	1	MECHANICAL TIMER ASSY*6 MIN 110V KNOB/DIAL/LT S2450/2451/VT
2	HL350-15-6M	1	TIMER ONLY*6 MIN NO KNOB&DIAL PLT S2450-01/VT/T AFT 11-17-06
3	HL3501216M	1	KNOB * FOR 6 MIN TIMER S2450/S2451/2400VT/2400T AFT 11-17-06
4	HL350396M	1	DIAL PLATE *FOR 6 MIN TIMER S2400/2401/VT/2400T AFT 11-17-06
5	HL44276	1	LIGHT * RED 110V 442/S2400/2401/VT/2400T AFT 11-17-06
6	HW300562P	4	SCREW * 6-32 x 3/8, PHILIPS OVAL HEAD, CSK,SS
10	HW50052P	4	LOCK WASHER, No. 6, EXTERNAL TOOTH, COUNTERSUNK
OPTIONAL ITEMS			
7	HL350-31	1	CYCLE COUNTER * S2450 SERIES AFT07-01-08
8	HL350A93	1	ELECTRONIC TIMER ASSY *3 PUSH BUTTONS NO TEXT S2400 P MODELS
9	HL350A939	1	ELECTRONIC TIMER PC BOARD ONLY * NO P/B FOR 350-A93 S2400 P

S2425 SERIES SHAKER STANDS



Part# HL350-A8D
Dual position stand
Will hold models S2425 or
S2450
(Shown holding S2450)



Part# HL350-A8Q
Four position stand
Will hold models S2425 or
S2450
(Shown holding S2450)

S2425 PARTS DIAGRAM

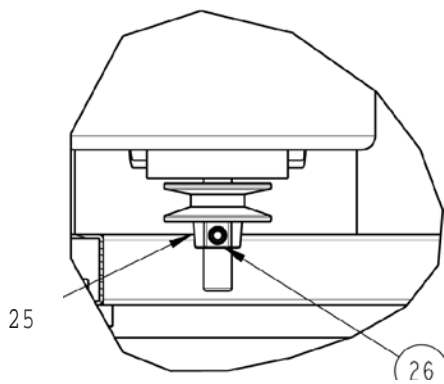
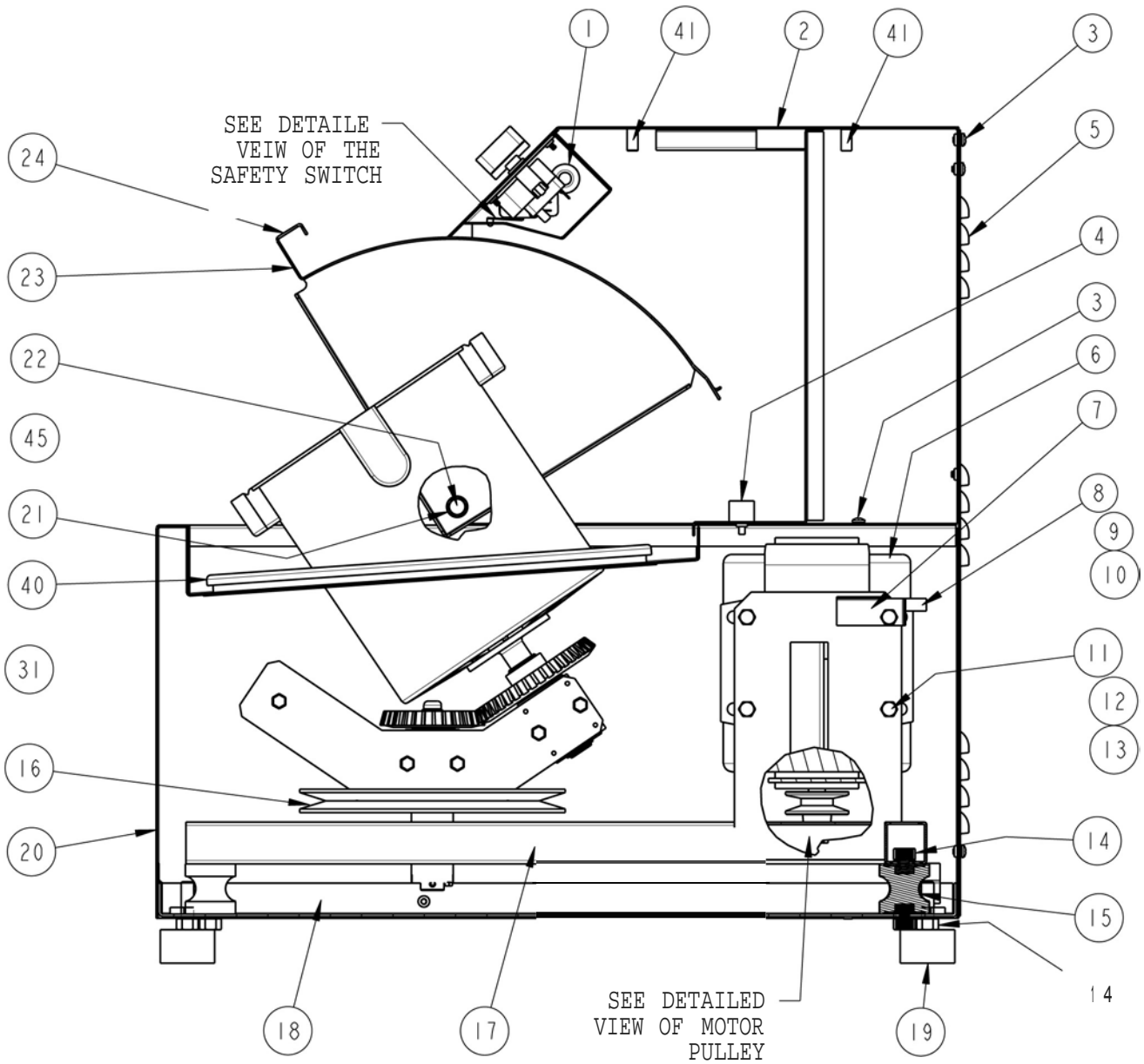

Fig 1: Detailed view of Motor Pulley

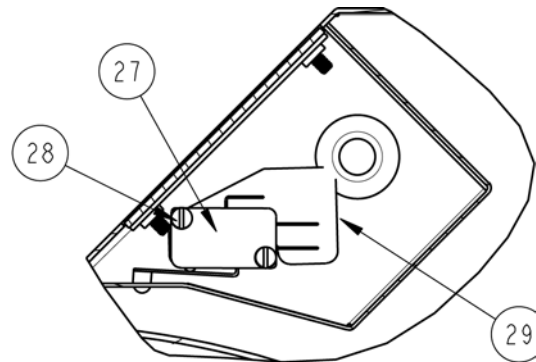

Fig 2: Detailed view of Safety Switch

Model 52425- Countertop One Gallon Dual Axis™ Mixer:
Part# HL350-A8- For floor stand base upgrade kit order part #HL350-A8

Model S2425 One Gallon Multi Mix™ Paint Mixer Part List

Ref #	Part #	Qty	Description
1	HL35011	1	CORD GROMMET * S2425 SERIES TIMER BOX
2	HI350A76	1	UPPER MACHINE SHELL ASSY * S2425 SERIES(04-29-08) MODELS
3	HW30382P	1	SCREW * MACHINE 10-32 X 1/4 TRUSS W/INTSEM WASHER PHIL PLTD
4	HL35097	1	S24XX DOOR BUMPER ASSEMBLY
5	HL3504	1	BACK PANEL ASSY * S2425 SW SERIES MODELS
6	HL35020	1	MOTOR * 110V 1/4 HP ALL S2400 SERIES MODELS EXCEPT 2400T
7	HL350201	1	BRACKET * HARNESS PLUG S2400/2400VT/2401/2400T AFT 11-17-06
8	HW5006P	1	WASHER * FLAT #6 SAE PLTD (WAS 473-130, 1101-136)
9	HL350137	1	CLAMP * CABLE NYLON 1/2 IN ALL S2400 SERIES MODELS
10	HW30056P	1	SCREW * MACHINE 6-32 X 3/8 PAN HD SL PLTD (WAS 473-48)
11	HW1020P	4	CAPSCREW * HEX HD 1/4NC X 3/4 GR5 PLTD (WAS 473-43)
12	HW5030P	4	WASHER * FLAT 1/4 SAE PLTD (WAS 473-50, 442-199)
13	HW4021P	4	NUT * KEP 1/4NC PLTD
14	HW4051P	10	NUT * HEX 3/8NC K-LOCK PLTD
15	HL350A15	3	SHOCK ASSY * C/W 2 K-NUTS ALL S2400 MODELS/HS1000
16	HL350-265	1	V BELT * S2425 AX37
17	HL350A5	1	T BAR ASSY * W/SET SCREWS AFT020808 ALL S2400 EXCEPT S2400T
18	HL350A14	1	MOTOR TRAY ASSY * ALL S2400 EXC S2400VT LOWER MODULE/HS1000
19	HL350A16	4	FOOT STUD ASSY * W/ K-NUT ALL S2400 MODELS/S2500/HS1000
20	HL350A74	1	LOWER MACHINE SHELL ASSEMBLY * S2425 SERIES MODELS
21	HL35013	2	BEARING * BRONZE SLEEVE S2425 SERIES DO
22	HW1050P	2	CAPSCREW * HEX HD 5/16NC X 1/2 GR5 PLTD
23	HL35010	1	FOAM RUBBER STRIP * S2425 SERIES DOOR
24	HL350A82	1	DOOR ASSY * W LABEL/RUBBER STRIP/BUSHINGS S2450 MODELS
25	HL350-264	1	PULLEY * MOTOR 1 1/2 IN
26	HW2011	1	SETSCREW * SKT HD 5/16NCX3/8 KNURLED PT(WAS 473-60,321-157)
27	HL35068	1	SWITCH * SAFTEY W/ ROLLER ALL S2425 SERIES AFT 4-2-08
28	HW3005P	2	SCREW * MACHINE 4-40 X 5/8 PAN HD PHIL PLTD (WAS 473-47,
29	HL44260	1	PAPER * INSULATING SAFETY & PGM SWITCHES 442/ALL S2400/1101
30	HL350A37	1	Optional * PAINT CONTAINMENT TRAY - Standard on S2450 SERIES MODELS

Model: S2425/S2450/S2451 Multi Mix™ Paint Mixer Warranty & Claim Procedures

I.C.T.C. Holdings is proud to offer an industry leading "Two Year Parts Warranty" and "One Year Labor Warranty" on all of its H.E.R.O. Shakers and Mixers

I.C.T.C. warrants it's paint mixer to be free of materials defects, to the original user, for a period of Two (2) Years. This warranty entitles the owner to parts replacement at no charge. The parts warranty is valid for any necessary replacement, whether caused by material, workmanship defect or simple wear, except as noted below.

Electric motors, timers and pneumatic motors warranted for twelve (12) months only.

The warranty is applicable to the original owner only and is non-transferable. The equipment must be , operated and maintained in accordance with all instructions, precautions and warnings contained in the owner's manual. For the purpose of this warranty, damage caused by accident, abuse, improper cleaning or lack thereof, or improper operation, is not covered. Cleaning and general maintenance is the responsibility of the owner / operator and is not covered by the warranty.

I.C.T.C.'s liability is limited to the replacement of parts found to be defective or worn and does not include damage or other expenses of any kind incurred in connection with the purchase and use of the dispenser.

