



The WAGNER TOPFINISH DD10 is the first air-operated double diaphragm pump which guarantees high-quality surfaces without the use of a material pressure regulator. This pump saves up to 70% solvent in clean-up.

- Typical savings can be around \$9,500 per year for reduced solvent usage and lower maintenance costs
- Change of diaphragm takes less than 15 minutes
- Perfectly suited for supplying material to manual or automatic airspray guns and 2-component systems
- Revolutionary concept for pulsation-free material flow without a material pressure regulator

Up to 70% savings in rinsing agent and waste with the WAGNER TOPFINISH DD10 - the first material feeding pump for airspray applications without material pressure regulator

- **Easy to use & time-saving** - Two precisely adjustable rotary regulators with pressure gauge for the pump pressure and atomization air
- **Rapid service** - You only need four standard tools to meet all of the pump's service requirements – quick and easy
- **Homogeneous spray pattern** - The revolutionary pump concept guarantees absolutely pulsation-free working, thus ensuring best surfaces
- **Built to last** - All parts coming into contact with liquid are made from stainless steel. This means all materials can be processed with one pump
- **Reliable operation** - The pump can be installed in any conceivable position without restricting its function
- **Simple integration** - The regulator unit can be installed either sideways or length-ways

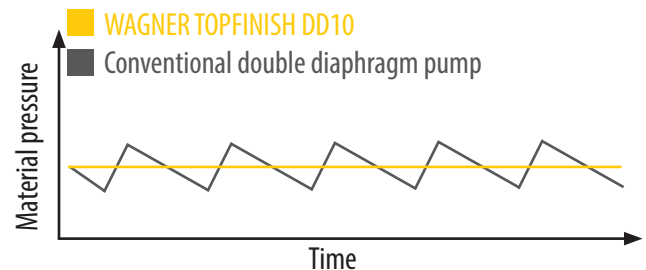
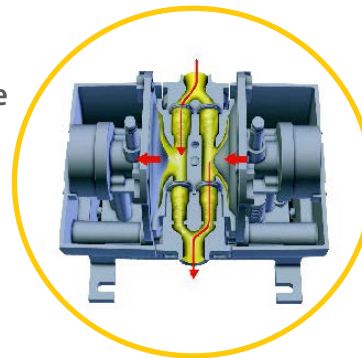

Two coupled diaphragms are moving from the left to the right and back by help of pressurized air. The steering valve guides the air to the side where the diaphragm is moved to contract the fluid chamber. Material is transported by contraction and expansion of the fluid chamber volume through the inlet and outlet valves.



TOPFINISH DD10

Double Diaphragm Pumps



DD10 Configurations

Mount Style	Part Number	Description
Bare Pump With Regulators	2414299	Bare DD10 pump with regulator set
Cart Mount	DD10-C5	Cart mounted DD10 with 5 gallon siphon
Wall Mount	DD10-W5	Wall mounted DD10 with 5 gallon siphon
5 Gallon Pail Mount	DD10-P5	5 Gallon pail mounted DD10
55 Gallon Drum Mount	DD10-DR55	55 Gallon drum mounted DD10



Cart Mount



Wall Mount



5 Gallon Pail Mount



55 Gallon Drum Mount



Cart and Wall Mount

Description	Part Number
Cart for DD10	2368424
Wall Mount Bracket	70-171



Circulation Fittings

Description	Part Number
Circulation with Filter	2368434
Circulation Fitting	2368428



Siphon Hoses

Description	Part Number
1/2" 5 Gal Siphon Hose	74-520
1/2" 55 Gal Siph. Hose	74-524
3/8" 5 Gal Siphon Hose	74-538



Wagner Industrial Solutions

Powder Division

1770 Fernbrook Lane
Plymouth, MN 55447
T 800.473.2524
F 630.503.2377

Liquid Division

337 South Arthur Ave
Louisville, CO 80027
T 888.820.4498
F 303.438.5708

www.wagnersystemsinc.com

