

BINKS[®]

Instruction Manual

Back Pressure Regulator (Low Shear ¾")

- 107757 - 15.0 Bar
- 107758 - Pilot Control



**BINKS****Product Description**BPR - 107757, 107758, 107748, 107749,
107750, 107754, 107755, PRV22**This Product is designed for use with:** Solvent and Water based Materials**Suitable for use in hazardous area:** Zone 1 & 2**Protection Level:** II 2 G X T4**Manufacturer:** Binks,
Justus-von-Liebig - Strasse,
63128 Dietzenbach. DE

EU Declaration of Conformity

We: Binks declare that the above product conforms with the Provisions of:

Machinery Directive 2006/42/EC

ATEX Directive 94/9/EC

by complying with the following statutory documents and harmonized standards:

EN ISO 12100: Safety of Machinery - General Principles for Design

EN ISO 4413: Hydraulic Fluid Power - General Rules and safety requirements

EN ISO 4414: Pneumatic Fluid Power - General Rules and safety requirements

EN1127-1: Explosive atmospheres - Explosion prevention - Basic concepts

EN 13463-1: Non electrical equipment for use in potentially explosive atmospheres - Basic methods and requirements

EN 13463-5: Non electrical equipment for use in potentially explosive atmospheres - Protection by constructional safety

Providing all conditions of safe use stated within the product manuals have been complied with and that the final equipment into which this product is installed has been re-assessed as required, in accordance with essential health and safety requirements of the above standards, directives and statutory instruments and also installed in accordance with any applicable local codes of practice.

D Smith (General Manager)

01 November 2012

Model Selection

(Manual Control) 107757
 (Pilot Control) 107758 R-S-T etc

107757 - X - X

BASIC PART NUMBER

INLET FITTING

OUTLET FITTING

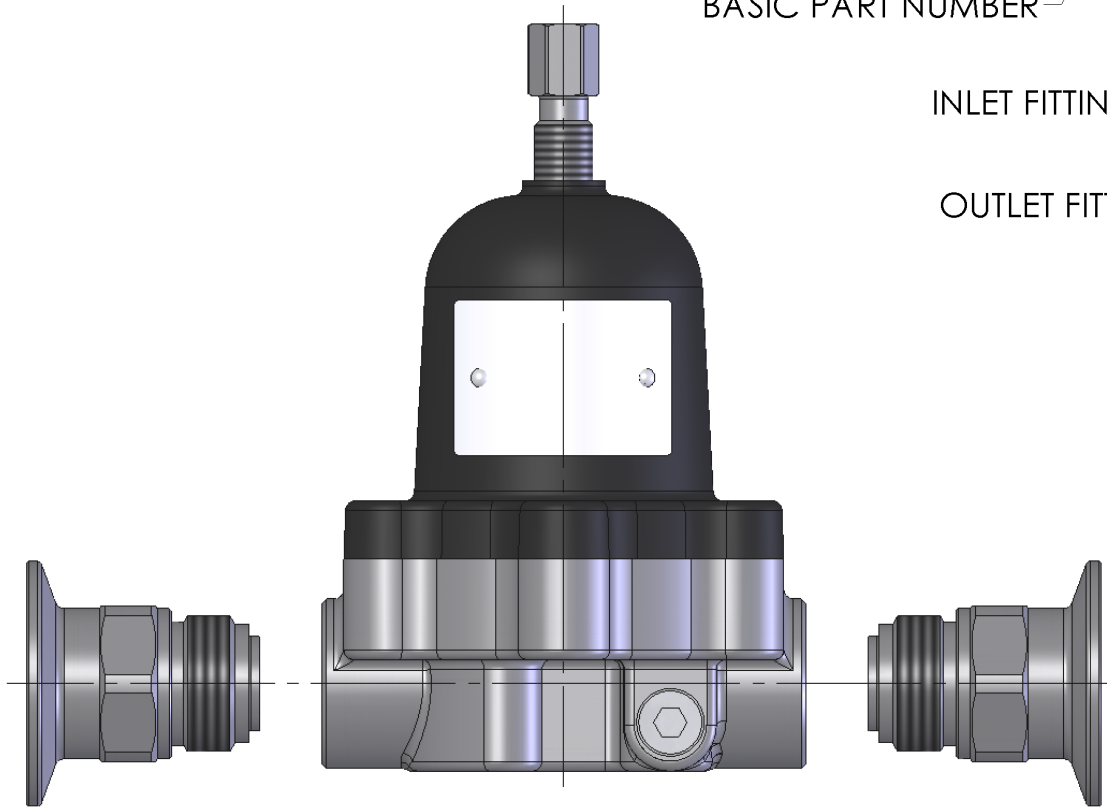

OUTLET FITTING

INLET FITTING

INLET / OUTLET FITTING SELECTION TABLE

| SUFFIX | PART No | DESCRIPTION | REMARKS |
|--------|---------|---|----------|
| R | 192722 | FITTING - M28 x 3/4" SANITARY | |
| S | 192723 | FITTING - M28 x 1" SANITARY | STANDARD |
| T | 192724 | FITTING - M28 x 3/4" NPT (FEMALE) | STANDARD |
| U | 192725 | FITTING - M28 x 3/4" BSPT (FEMALE) | STANDARD |
| V | 192726 | FITTING - M28 x 28MM COMPRESSION COUPLING | |
| W | 192727 | FITTING - M28 x 3/4" BSP (H) | |
| Y | 194283 | FITTING - M28 x 1/2" BSPT (FEMALE) | |

Installation - Mounting

1. Connect the unit into the paint system pipework in the direction indicated by the arrow on the valve body.

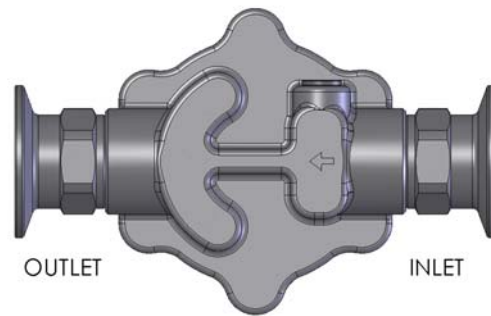

2. Always connect the unit using the correct fittings /gaskets and if a threaded fitting is used a suitable thread compatible sealant.
3. A pressure gauge should be mounted directly into the pipework on the inlet side of the unit to allow precise adjustment for the regulated back pressure. Alternatively 1 off gauge connection port provided in the valve body can be used.

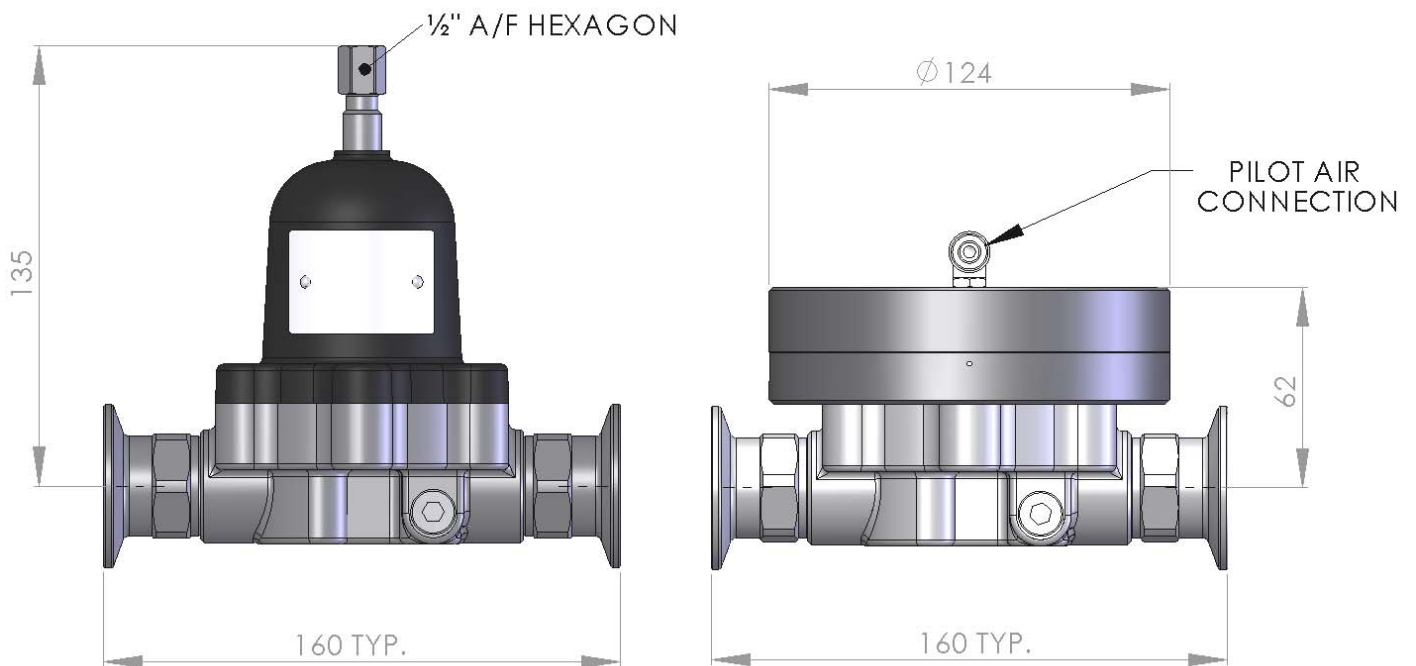

Installation – Setting to work

The Back pressure regulator is tested with demineralised water, therefore the fluid chamber should be flushed with suitable material prior to use.

Note: Before attempting any maintenance ensure that all relevant directions for working safety are followed.

1. If circulating system pressure testing is carried out with the back pressure regulator in circuit, the fluid test pressure must not exceed 25 Bar and the back pressure valve **must** 'be unloaded' have no spring pressure (or air pressure) acting on the diaphragm.
2. When the paint pipework is to be flushed with the back pressure regulator installed, the back pressure regulator **must not** have any spring pressure (or air pressure) acting on the diaphragm. This status must remain until the paint system has been accepted as clean and contaminant free.
3. Following pressure testing and flushing procedures the diaphragms should be examined and replaced if necessary to ensure the integrity of the unit prior to use in production.
4. Turning the main adjusting screw clockwise will increase the spring pressure on the unit and therefore the fluid back pressure on the paint system. Turning the screw anti-clockwise will decrease back pressure. The Pilot controlled unit operates in the same way, an increase in pilot air pressure increases the system back pressure.
5. Adjust the spring (or pilot air pressure) until the desired system fluid back pressure is achieved on the pressure gauge in the BPR inlet pipework.

| Model | Ideal Working Range | | Max Static Pressure | Wetted Materials |
|--------|---------------------|--------------|---------------------|-----------------------------|
| 107757 | 3-15 Bar | 2 – 30 L/min | 25 Bar | 300 Series ST ST and F.E.P. |
| 107758 | 3-15 Bar | 2 – 30 L/min | 25 Bar | |

Parts Lists

| Parts List - 107758 (Pilot Control) | | | | |
|-------------------------------------|-------------|----------------------|-----|---------|
| Item | Part No. | Description | Qty | Remarks |
| 1 | 0115-010600 | 1/4" NPT PLUG | 1 | |
| 2 | 161982 | O-RING - PTFE | 2 | |
| 3 | 165542 | M6 x 12 CAP HD SCREW | 6 | 12 Nm |
| 4 | 163921 | M6 x 25 CAP HD SCREW | 10 | 12 Nm |
| 5 | 164838 | RIVET | 2 | |
| 6 | 192147 | NAMEPLATE | 1 | |
| 7 | 192577 | DIAPHRAGM - PILOT | 1 | # |
| 8 | 192661 | PUSH IN ELBOW | 1 | |
| 9 | 193139 | BPR BASE | 1 | |
| 10 | 193141 | CAP - PILOT | 1 | |
| 11 | 193142 | BASE - PILOT | 1 | |
| 12 | 193143 | DIAPHRAGM PLATE | 1 | |
| 13 | 193233 | COMPOSITE DIAPHRAGM | 1 | # |
| # Included in 250675 Spares Kit | | | | |

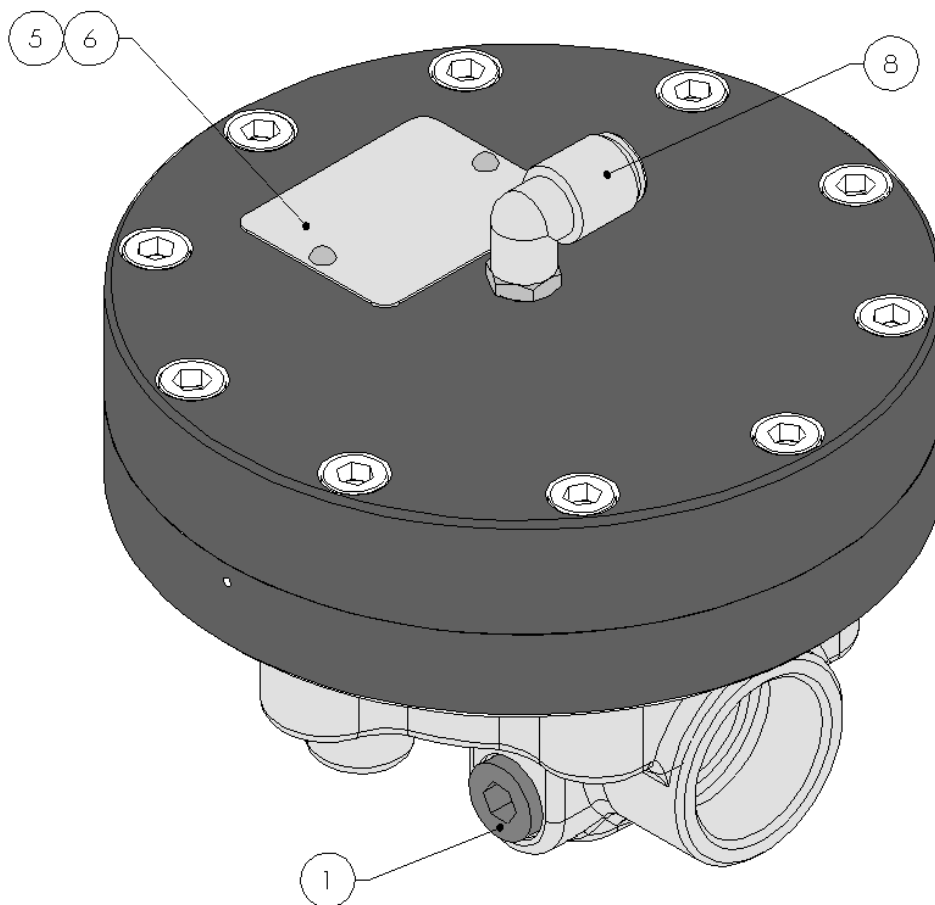

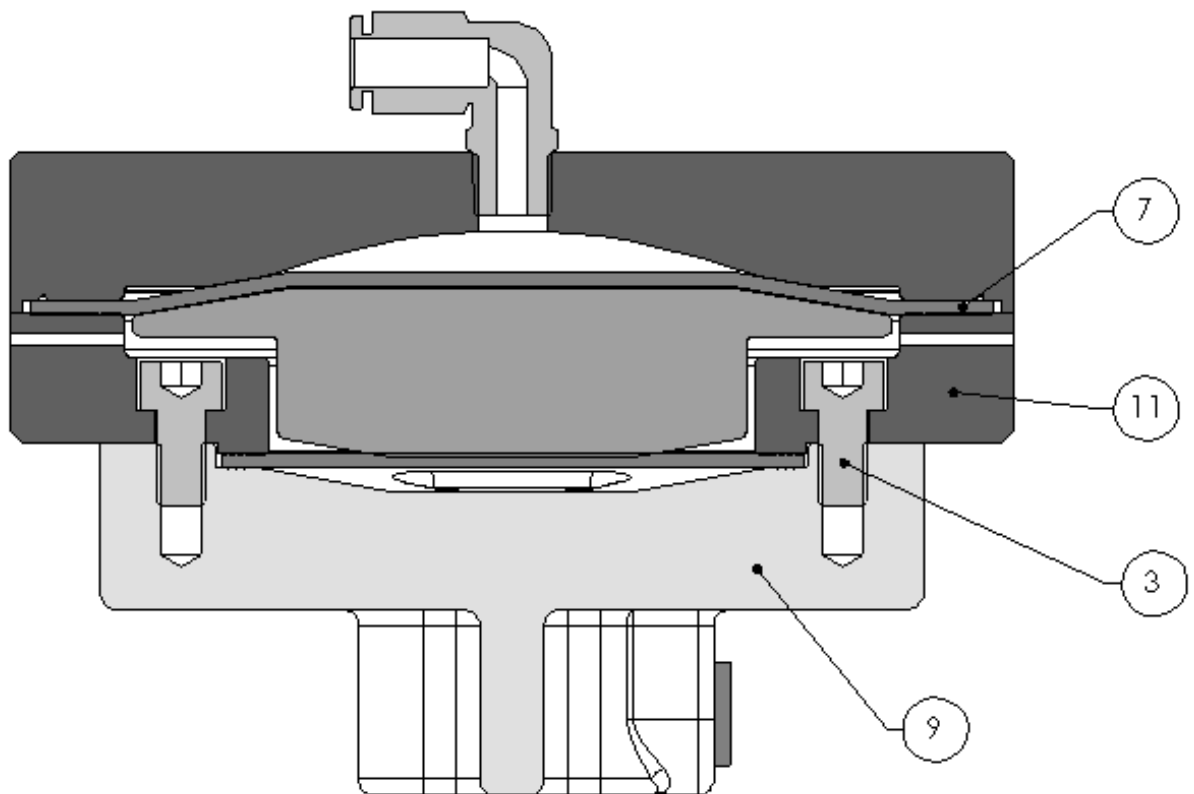
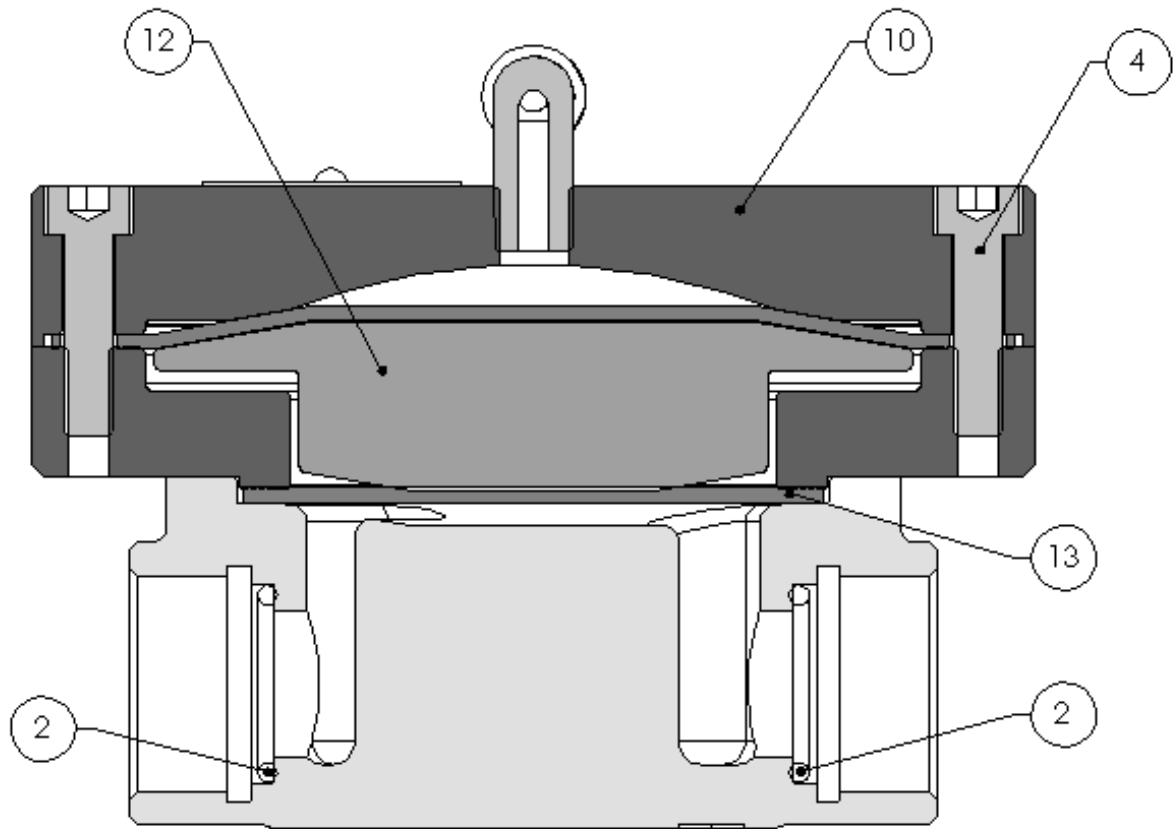

Parts Lists

| Parts List - 107757 (15.0 Bar) | | | | |
|--------------------------------|-------------|---------------------|-----|---------|
| Item | Part No. | Description | Qty | Remarks |
| 1 | 0115-010600 | 1/4" NPT PLUG | 1 | |
| 2 | 160186 | SPRING | 1 | |
| 3 | 161982 | O-RING - PTFE | 2 | |
| 4 | 163951 | M6 x 16 CAP SCREW | 6 | 12 Nm |
| 5 | 164838 | RIVET | 2 | |
| 6 | 185010 | SPRING BUTTON | 1 | |
| 7 | 192147 | NAMEPLATE | 1 | |
| 8 | 192469 | SPRING DISC | 1 | |
| 9 | 193139 | BPR BASE | 1 | |
| 10 | 193140 | BONNET | 1 | |
| 11 | 193144 | ADJUSTING SCREW | 1 | |
| 12 | 193233 | COMPOSITE DIAPHRAGM | 1 | |

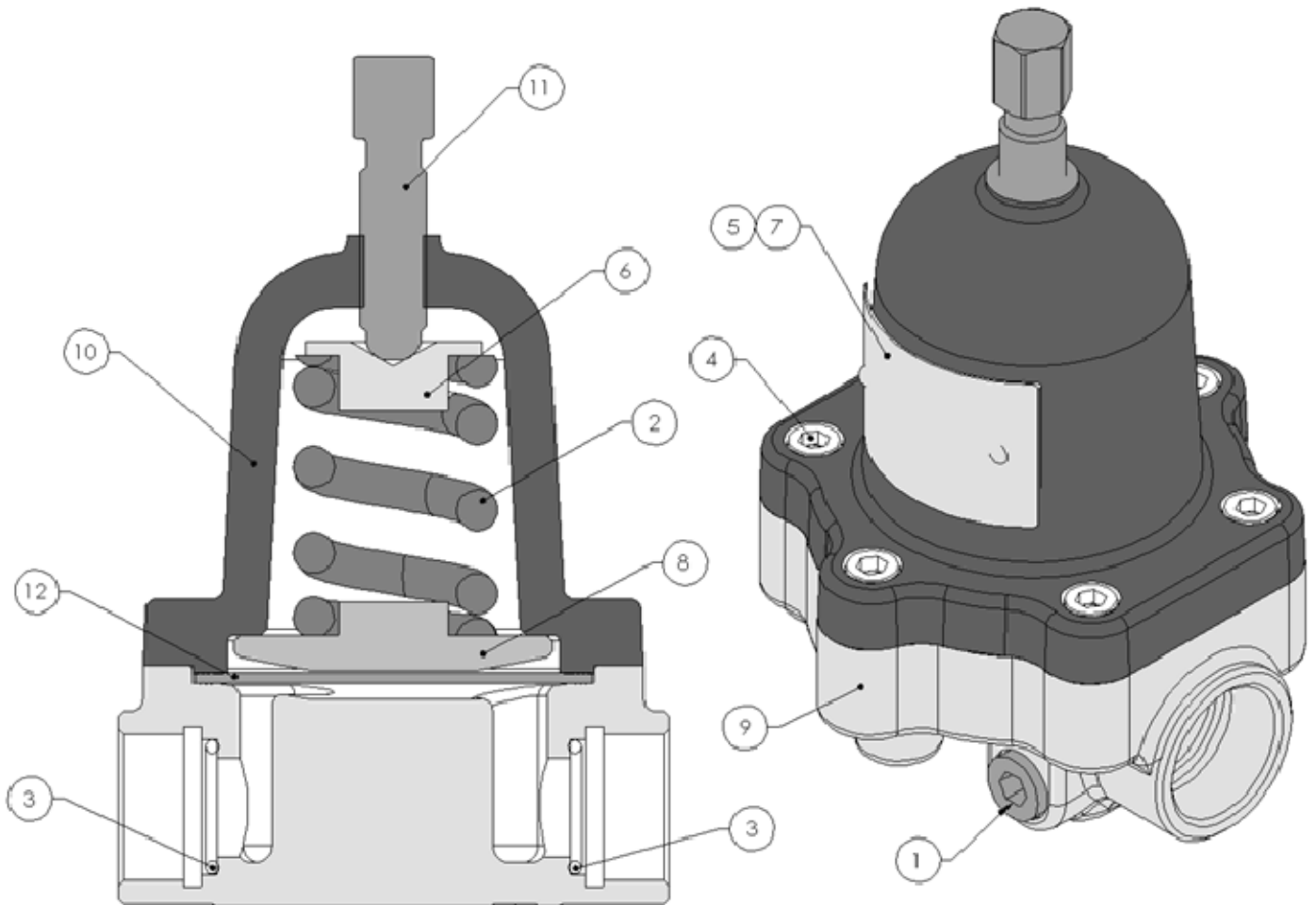

Assembly Procedure

The Back pressure regulator can be serviced and maintained without removing the unit from the paint pipework.

1. Fully unscrew the adjusting screw to remove all paint line pressure. (or exhaust the compressed air pilot supply)
2. Isolate the unit from the paint system pipework (and compressed air supply if applicable)
3. Position a 'drip tray' underneath the unit to minimise any paint spillage.
4. Unscrew the 6 off bonnet screws by 2 turns and pull the bonnet away from the unit; this should then release any residual paint within the unit. Fully remove the 6 off bonnet screws.

For the air pilot controlled version firstly remove the 10 off screws retaining the air pilot cap and remove with the diaphragm.

5. Remove the bonnet and diaphragms. Clean all parts as required
6. Reassemble the unit with new diaphragms.
Tighten the 6 off Bonnet screw to 12 N-M (9 foot-pound) Tighten opposed screws in stages to maintain an even clamping force.
7. Pressure test with 6 bar compressed air and check for leaks.
8. Reintroduce the paint system pressure and adjust the back pressure regulator to the required setting.

Spare Parts List

| 107758 Spare Parts Kit - 250675 | | | | |
|--|-----------------|-----------------------|------------|----------------|
| Item | Part No. | Description | Qty | Remarks |
| 1 | 193233 | Diaphragm (Composite) | 1 | Fluid |
| 2 | 192577 | Diaphragm | 1 | Air |
| | | | | |
| | | | | |

 **WARNING**

Directions for Working Safety







This Product has been constructed according to advanced technological standards and is operationally reliable. Damage may, however, result if it is used incorrectly by untrained persons or used for purposes other than those for which it was constructed.

The locally current regulations for safety and prevention of accidents are valid for the operation of this product under all circumstances.

International, national and company safety regulations are to be observed for the installation and operation of this product, as well as the procedures involved in maintenance, repairs and cleaning.

These instructions are intended to be read, understood and observed in all points by those responsible for this product. These operating and maintenance instructions are intended to ensure trouble free operation. Therefore, it is recommended to read these instructions carefully before start-up. Binks PCE cannot be held responsible for damage or malfunctions resulting from the non-observance of the operating instructions. These instructions including regulations and technical drawings may not be copied, distributed, used for commercial purposes or given to others either in full or in part without the consent of Binks PCE.

We reserve the right to alter drawings and specifications necessary for the technical improvement of this product without notice.

| | |
|---|--|
|    | <p>Equipment Misuse Hazard</p> <p>Equipment misuse can cause the equipment to rupture or malfunction and result in serious injury.</p> <ul style="list-style-type: none"> • This equipment is for professional use only. • Read all instruction manuals, tags, and labels before operating the equipment. • Use the equipment only for its intended purpose. • Do not alter or modify this equipment. Use only genuine Binks PCE parts and accessories. • Check equipment daily. Repair or replace worn or damaged parts immediately. • Do not exceed the maximum working pressure stated on the equipment or in the Technical Data for your equipment. Do not exceed the maximum working pressure of the lowest rated component in your system. • Use fluids and solvents which are compatible with the equipment wetted parts. Refer to the Technical Data section of all equipment manuals. Read the fluid and solvent manufacturer's warnings. • Route hoses away from traffic areas, sharp edges, moving parts, and hot surfaces. Do not expose hoses to temperatures above 82°C (180°F) or below -40°C (-40°F). • Do not lift pressurized equipment. • Comply with all applicable local, state, and national fire, electrical, and safety regulations. |
|    | <p>Fire, Explosion and Electric Shock Hazard</p> <p>Improper grounding, poor ventilation, open flames or sparks can cause a hazardous condition and result in a fire, explosion, or electric shock.</p> <p>When installed and operated in accordance with its instructions, the pump is approved for operation in Zone 1 (Europe) & Division 1 (North America), hazardous locations. (ATEX Cat 2)</p> <ul style="list-style-type: none"> • Electrical equipment must be installed, operated, and serviced only by trained, qualified personnel who fully understand the requirements stated in this instruction manual. • Ground the equipment and all other electrically conductive objects in the spray area. After grounding test with ohmmeter to ensure earth continuity is 1 ohm or less. • Keep all covers tight while the motor is energized. • If there is any static sparking or you feel an electric shock while using this equipment, stop spraying/dispersing immediately. Do not use the equipment until you identify and correct the problem. • Provide fresh air ventilation to avoid the build up of flammable fumes from solvents or the fluid being pumped. • Keep the pumping area free of debris, including solvent, rags, and gasoline. • Electrically disconnect all equipment in the pumping area. • Extinguish all open flames or pilot lights in the spray/dispense area. • Do not smoke in the spray/dispense area. • Do not turn on or off any light switch in the spray/dispense area while operating or if fumes are present. |



WARNING



READ THE MANUAL

Before operating equipment, read and understand all safety, operation and maintenance information provided in the operation manual.



DE-ENERGIZE, DEPRESSURIZE, DISCONNECT AND LOCK OUT ALL POWER SOURCES DURING MAINTENANCE

Failure to De-energize, disconnect and lock out all power supplies before performing equipment maintenance could cause serious injury or death.



OPERATOR TRAINING

All personnel must be trained before operating equipment.



KEEP EQUIPMENT GUARDS IN PLACE

Do not operate the equipment if the safety devices have been removed.

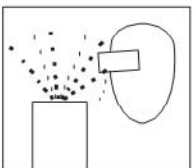

PROJECTILE HAZARD

You may be injured by venting liquids or gases that are released under pressure, or flying debris.



PINCH POINT HAZARD

Moving parts can crush and cut. Pinch points are basically any areas where there are moving parts.

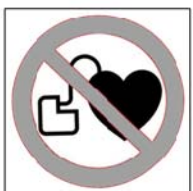

MAGNETIC FIELD PRESENT

You may be subjected to magnetic fields which may interfere with the operation of certain pacemakers.



WEAR SAFETY GLASSES

Failure to wear safety glasses with side shields could result in serious eye injury or blindness.



NOISE HAZARD

You may be injured by loud noise. Hearing protection may be required when using this equipment.



KNOW WHERE AND HOW TO SHUT OFF THE EQUIPMENT IN CASE OF AN EMERGENCY



HIGH PRESSURE CONSIDERATION

High pressure can cause serious injury. Relieve all pressure before servicing. Hose leaks, or ruptured components can inject fluid into your body and cause extremely serious injury.



AUTOMATIC EQUIPMENT

Automatic equipment may start suddenly without warning.

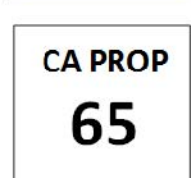

PROP 65 WARNING

WARNING: This product contains chemicals known to the State of California to cause cancer and birth defects or other reproductive harm.



MAGNET HAZARD

Take care when handling magnets. Avoid getting magnets in close proximity of each other. Injury or damage to magnets may result.



Justus-von-Liebig-Straße 31, 63128 Dietzenbach. DE
Tel. +49 (0) 6074 403 1 Fax. +49 (0) 607 403 300
General e-mail: info@finishingbrands.eu

Ringwood Road, Bournemouth, Dorset BH11 9LH. UK
Tel. +44 (0)1202 571 111 Fax. +44 (0)1202 573 488
General e-mail: info@finishingbrands.eu

163-171, Av. des Auréats, 26014 Valence cedex. FR
Téléphone : +33 (0) 4 75 75 27 53 Télécopie: +33 (0) 4 75 75 27 79
General e-mail: info@finishingbrands.eu

USA Canada Customer Service

195 Internationale Blvd.
Glendale Height,IL 60139
630-237-5000

Toll Free Customer Service and
Technical Support 800-992-4657
Toll Free Facsimile 800-246-5732