

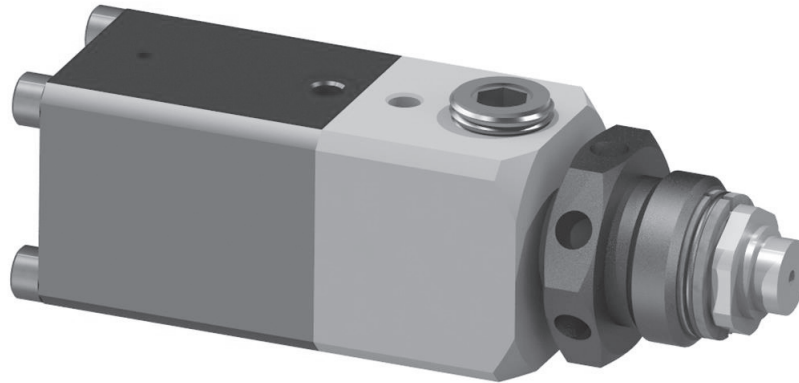

## 240-2012 HIGH PRESSURE CCV VALVE



### SPECIFICATIONS

Maximum air inlet pressure (both models):	7 bar [105 psi]
Air requirements (operating pressure):	4.8-6.9 bar [70-100 psi]
Air inlet connection port:	M5 x 0.8 (f)
Maximum fluid pressure:	207 bar [3000 psi]
Fluid connection ports (2x):	1/4" NPT (f)
Valve actuation speed (ON/OFF cycles):	55 cycles/min

Pressure Drop w/ 70 cP Test Fluid: (Varies w/ material press. and viscosity)	1 PSI press. drop @ 500 PSI and 200 cc/min
	7 PSI press. drop @ 500 PSI and 1000 cc/min
	43 PSI press. drop @ 500 PSI and 3800 cc/min

### **WARNING**

**Some materials and catalysts are extremely dangerous. Wear proper PPE during installation and maintenance. Consult the material SDS sheet for specific PPE requirements.**

### **WARNING**

**Know your operating pressures! Use only Binks hoses and fittings rated for the required operating pressures for use with this product. See maximum air and fluid pressure for each model listed in the specifications.**

<b>Product Description / Object of Declaration:</b>	<b>CCV Valves - CCV-403-SS, CCV-403-SS-E,CCV-503-SS, 240-2012, 240-2012-AC</b>	<b>EN</b>
<b>This Product is designed for use with:</b>	<b>Solvent and Water based materials</b>	
<b>Suitable for use in hazardous area:</b>	<b>Zone 1 / Zone 2</b>	
<b>Protection Level:</b>	<b>II 2 G X / Ex h II Gb</b>	
<b>Notified body details and role:</b>	<b>Element Materials Technology (2812)</b>	
	<b>Lodging of Technical file</b>	
<b>This Declaration of conformity / incorporation is issued under the sole responsibility of the manufacturer:</b>	<b>Carlisle Fluid Technologies UK Ltd,</b>	
<b>Representative authorised to compile the technical file</b>	<b>Ringwood Road,</b>	
	<b>Bournemouth, BH11 9LH. UK</b>	
	<b>Sales and Marketing Director. CFT UK Ltd</b>	
	<b>1 Avenue de Lattre de Tassigny</b>	
	<b>94736 Nogent, Cedex. France</b>	

**EU Declaration of Conformity**



**This Declaration of conformity / incorporation is issued under the sole responsibility of the manufacturer:**



Machinery Directive 2006/42/EC  
 ATEX Directive 2014/34/EU  
 by complying with the following statutory documents and harmonized standards:  
 EN ISO 12100:2010 Safety of Machinery - General Principles for Design  
 EN 1127-1:2019 Explosive atmospheres - Explosion prevention - Basic concepts  
 EN ISO 80079-36:2016 Explosive Atmospheres- Part 36: Non Electrical equipment for explosive atmospheres- Basic methods and requirements.  
 EN ISO 80079-37:2016 Explosive Atmospheres- Part 37: Non Electrical equipment for explosive atmospheres - protection by methods "c", "b" and "k".

Providing all conditions of safe use / installation stated within the product manuals have been complied with and also installed in accordance with any applicable local codes of practice.

Signed for and on behalf of  
 Carlisle Fluid Technologies  
 UK Ltd:

F. A. Sutter Executive President: Engineering  
 and Operations, Scottsdale, AZ,  
 85254. USA

12/9/22

<b>Product Description / Object of Declaration:</b>	<b>CCV Valves - CCV-403-SS, CCV-403-SS-E,CCV-503-SS, 240-2012, 240-2012-AC</b>	<b>EN</b>
<b>This Product is designed for use with:</b>	<b>Solvent and Water based materials</b>	
<b>Suitable for use in hazardous area:</b>	<b>Zone 1 / Zone 2</b>	
<b>Protection Level:</b>	<b>II 2 G X / Ex h II Gb</b>	
<b>Notified body details and role:</b>	<b>Element Materials Technology (0891)</b>	
	<b>Lodging of Technical file</b>	
<b>This Declaration of conformity/incorporation is issued under the sole responsibility of the manufacturer:</b>	<b>Carlisle Fluid Technologies UK Ltd, Ringwood Road, Bournemouth, BH11 9LH. UK</b>	
<b>UKCA Declaration of Conformity</b>		<b>UK CA</b> 
<b>This Declaration of conformity/incorporation is issued under the sole responsibility of the manufacturer:</b>		
<p>Supply of Machinery (Safety) Regulations 2008  Equipment and Protective Systems Intended for use in Potentially Explosive Atmospheres Regulations 2016  by complying with the following statutory documents and harmonised standards:  BS EN ISO 12100:2010 Safety of Machinery - General Principles for Design  BS EN 1127-1:2019 Explosive atmospheres - Explosion prevention - Basic concepts  BS EN ISO 80079-36:2016 Explosive Atmospheres- Part 36: Non Electrical equipment for explosive atmospheres-Basic methods and requirements.  BS EN ISO 80079-37:2016 Explosive Atmospheres- Part 37: Non Electrical equipment for explosive atmospheres - protection by methods "c", "b" and "k".</p>		
Providing all conditions of safe use/installation stated within the product manuals have been complied with and also installed in accordance with any applicable local codes of practice.		
Signed for and on behalf of Carlisle Fluid Technologies UK Ltd:		<b>F. A. Sutter</b> Executive President: Engineering and Operations, Scottsdale, AZ, 85254. USA  12/9/22

In this part sheet, the words **WARNING**, **CAUTION** and **NOTE** are used to emphasize important safety information as follows:

## **WARNING**

Hazards or unsafe practices which could result in severe personal injury, death or substantial property damage.

## **CAUTION**

Hazards or unsafe practices which could result in minor personal injury, product or property damage.

## **NOTE**

Important installation, operation or maintenance information.

## **WARNING**

### Read the following warnings before using this equipment.



#### **READ THE MANUAL**

Before operating finishing equipment, read and understand all safety, operation and maintenance information provided in the operation manual.



#### **WEAR SAFETY GLASSES**

Failure to wear safety glasses with side shields could result in serious eye injury or blindness.



#### **DE-ENERGIZE, DEPRESSURIZE, DISCONNECT AND LOCK OUT ALL POWER SOURCES DURING MAINTENANCE**

Failure to De-energize, disconnect and lock out all power supplies before performing equipment maintenance could cause serious injury or death.



#### **OPERATOR TRAINING**

All personnel must be trained before operating finishing equipment.



#### **EQUIPMENT MISUSE HAZARD**

Equipment misuse can cause the equipment to rupture, malfunction, or start unexpectedly and result in serious injury.

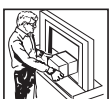

#### **KEEP EQUIPMENT GUARDS IN PLACE**

Do not operate the equipment if the safety devices have been removed.

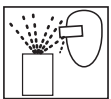

#### **PROJECTILE HAZARD**

You may be injured by venting liquids or gases that are released under pressure, or flying debris.



#### **PINCH POINT HAZARD**

Moving parts can crush and cut. Pinch points are basically any areas where there are moving parts.



#### **PACEMAKER WARNING**

You are in the presence of magnetic fields which may interfere with the operation of certain pacemakers.



#### **AUTOMATIC EQUIPMENT**

Automatic equipment may start suddenly without warning.



#### **INSPECT THE EQUIPMENT DAILY**

Inspect the equipment for worn or broken parts on a daily basis. Do not operate the equipment if you are uncertain about its condition.



#### **NEVER MODIFY THE EQUIPMENT**

Do not modify the equipment unless the manufacturer provides written approval.



#### **KNOW WHERE AND HOW TO SHUT OFF THE EQUIPMENT IN CASE OF AN EMERGENCY**



#### **PRESSURE RELIEF PROCEDURE**

Always follow the pressure relief procedure in the equipment instruction manual.



#### **NOISE HAZARD**

You may be injured by loud noise. Hearing protection may be required when using this equipment.



#### **HIGH PRESSURE CONSIDERATION**

High pressure can cause serious injury. Relieve all pressure before servicing. Spray from the spray gun, hose leaks, or ruptured components can inject fluid into your body and cause extremely serious injury.



#### **STATIC CHARGE**

Fluid may develop a static charge that must be dissipated through proper grounding of the equipment, objects to be sprayed and all other electrically conductive objects in the dispensing area. Improper grounding or sparks can cause a hazardous condition and result in fire, explosion or electric shock and other serious injury.

**IT IS THE RESPONSIBILITY OF THE EMPLOYER TO PROVIDE THIS INFORMATION TO THE OPERATOR OF THE EQUIPMENT. FOR FURTHER SAFETY INFORMATION REGARDING THIS EQUIPMENT, SEE THE GENERAL EQUIPMENT SAFETY BOOKLET (77-5300).**

## 240-2012 HIGH PRESSURE CCV VALVES

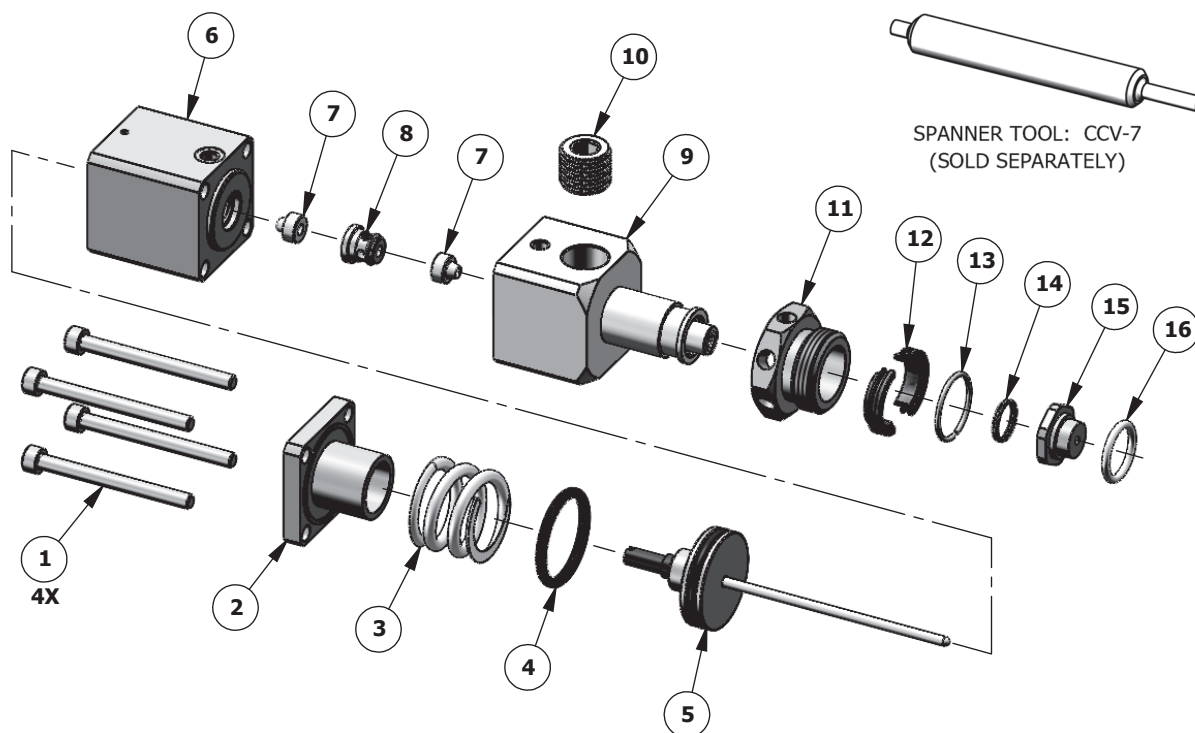

### PARTS LIST

Item No.	Part No.	Description	Qty.
1	240-2026	M4 x .7 x 45 SHCS SS, 4-PACK	4
2	240-2017	END CAP	1
3	240-2037	RETURN SPRING	1
4	SPA-122X	•◆ O-RING	1
5	240-2013-K	• FLUID NEEDLE ASSEMBLY	1
6	240-2016	BODY	1
7	240-2025-K2	◆ NEEDLE SEAL, 2-PACK	1
8	240-2035	SEAL SPACER	1
9	240-2022-1	VALVE HEAD	1

Item No.	Part No.	Description	Qty.
10	SSP-1421	PIPE PLUG, 1/4"	1
11	CCV-13	SPANNER NUT	1
12	240-2030	SPLIT COLLAR	1
13	240-2032	SPRING CLIP	1
14	240-2047	○ HOUSING SEAL	1
15	240-2044-1	○ SEAT ASSEMBLY	1
16	240-2057	○ SEAL	1

**The following quantity packs are also available:**

240-2057-K5 Seal 5-Pack  
240-2032-K5 Spring Clip 5-Pack

**Also Available:** 240-2056 Seal Tool Kit. See page 5.

**Parts are included within the following service kits:**

- ◆ 240-2048 Seal Kit
- 240-2049 Seat Kit for 240-2012
- Included in 240-2013-K

## 240-2012 MAINTENANCE

DISASSEMBLY ORDER SHOWN. REVERSE FOR REASSEMBLY.

### MAINTENANCE SYMBOLS:

- # = ITEM NUMBER (see page 1)
- 243 = THREAD LOCKER  
LOCTITE # or equivalent
- PG = PETROLEUM GREASE/JELLY  
Part number = AGMD-010
- # = TORQUE VALUE  
Nm [in-lb or ft-lb]

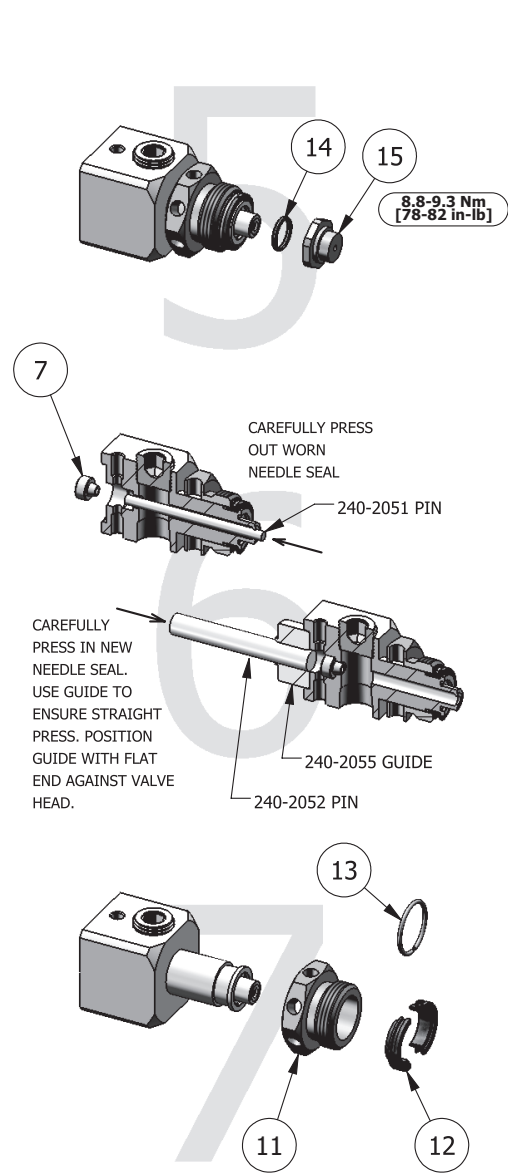
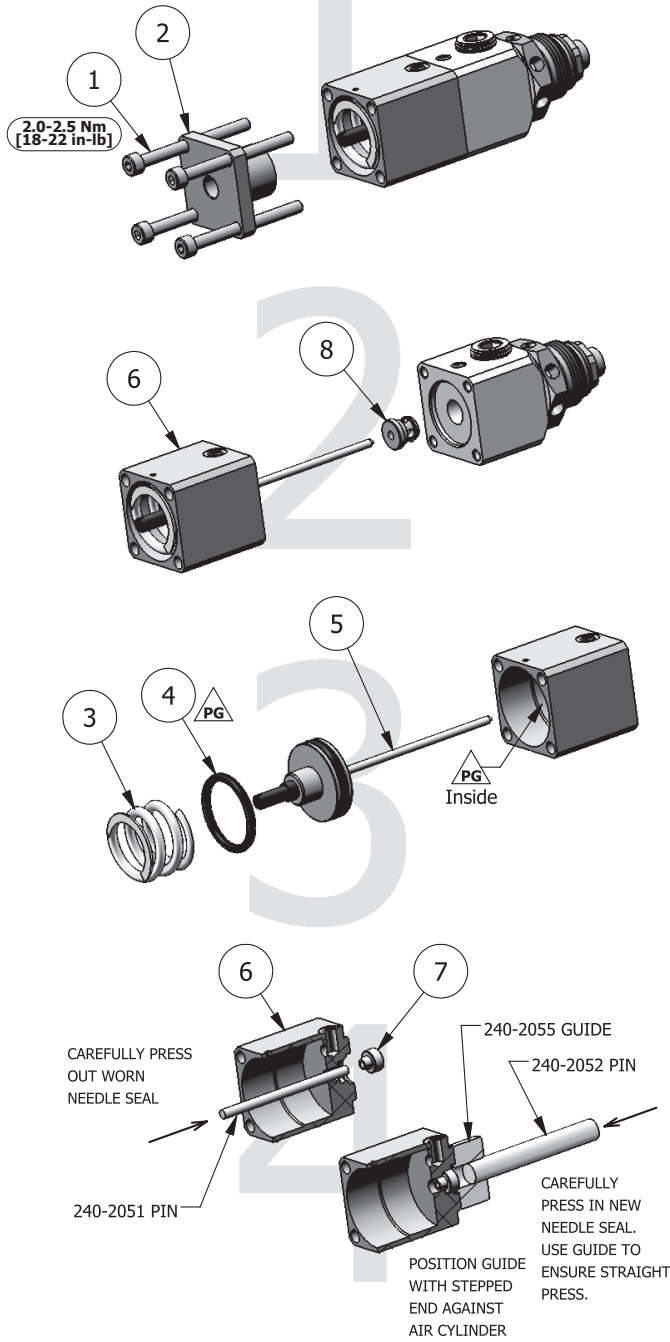

### 240-2056 SEAL TOOL KIT (See steps 4 & 6)

PART NO	DESCRIPTION	QTY.
240-2051	PIN, REMOVAL	1
240-2052	PIN, INSERTION	1
240-2055	GUIDE	1

## CCV-7 VALVE TOOL

### How to install Color Change Valve (CCV) using the CCV-7 Valve Tool

**Tighten securely. Test for leaks.**

#### NOTE

A 1-1/16 Wrench may be used to tighten the CCV to the block instead of the CCV-7 Tool.

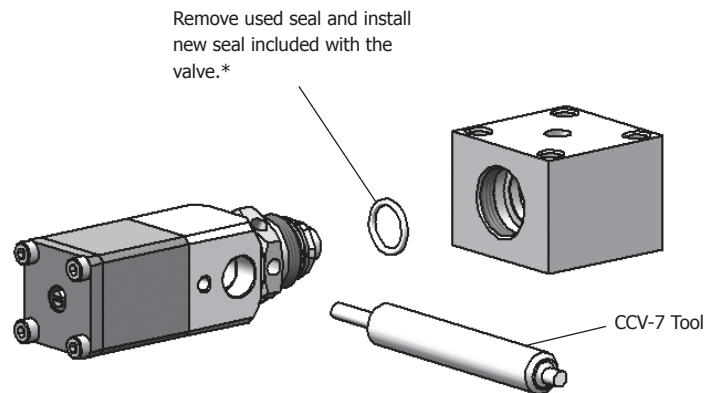

\*Seal also available in 240-2057-K5 quantity pack.

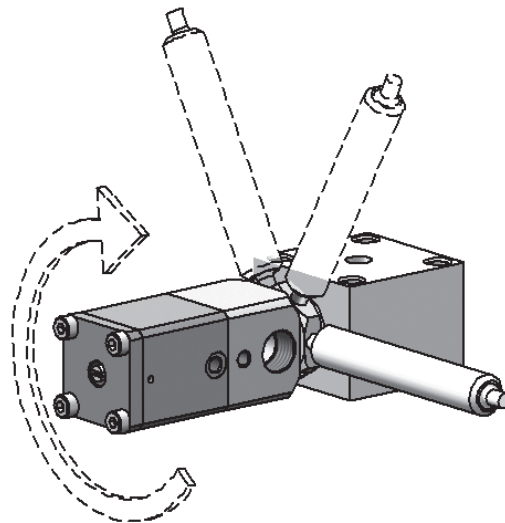

#### CAUTION

When installing the CCV valve assembly into a manifold block, DO NOT use pipe sealant or PTFE tape.

The CCV must be supported while tightening fittings into the 1/4 NPT ports. Or, the fittings may be installed prior to assembling the valve to a block or valve stack.

---

## WARRANTY POLICY

This product is covered by Carlisle Fluid Technologies' materials and workmanship limited warranty. The use of any parts or accessories, from a source other than Carlisle Fluid Technologies, will void all warranties. Failure to reasonably follow any maintenance guidance provided may invalidate any warranty.

For specific warranty information please contact Carlisle Fluid Technologies.

---

For technical assistance or to locate an authorized distributor, contact one of our international sales and customer support locations.

<b>Region</b>	<b>Industrial / Automotive</b>	<b>Automotive Refinishing</b>
Americas	Tel: 1-800-992-4657 Fax: 1-888-246-5732	Tel: 1-800-445-3988 Fax: 1-800-445-6643
Europe, Africa, Middle East, India	Tel: +44 (0)1202 571 111 Fax: +44 (0)1202 573 488	
China	Tel: +8621-3373 0108 Fax: +8621-3373 0308	
Japan	Tel: +81 45 785 6421 Fax: +81 45 785 6517	
Australia	Tel: +61 (0) 2 8525 7555 Fax: +61 (0) 2 8525 7575	

For the latest information about our products, visit [www.carlisleleft.com](http://www.carlisleleft.com)

---

Carlisle Fluid Technologies is a global leader in innovative finishing technologies. Carlisle Fluid Technologies reserves the right to modify equipment specifications without prior notice.

BGK™, Binks®, DeVilbiss®, Hosco®, MS®, and Ransburg® are all registered trademarks of Carlisle Fluid Technologies, LLC.

©2022 Carlisle Fluid Technologies, LLC.  
All rights reserved.



16430 North Scottsdale Rd., Suite 450 Scottsdale, AZ 85254 USA SOLUTIONS FOR YOUR WORLD