

BINKS® AIR VALVE SERVICE KIT NO. 54-6131-K

NOT INCLUDED
NO INCLUIDO
NON INCLU
NICHT IM LIEFERUMFANG ENTHALTEN
NON INCLUSO
不包括

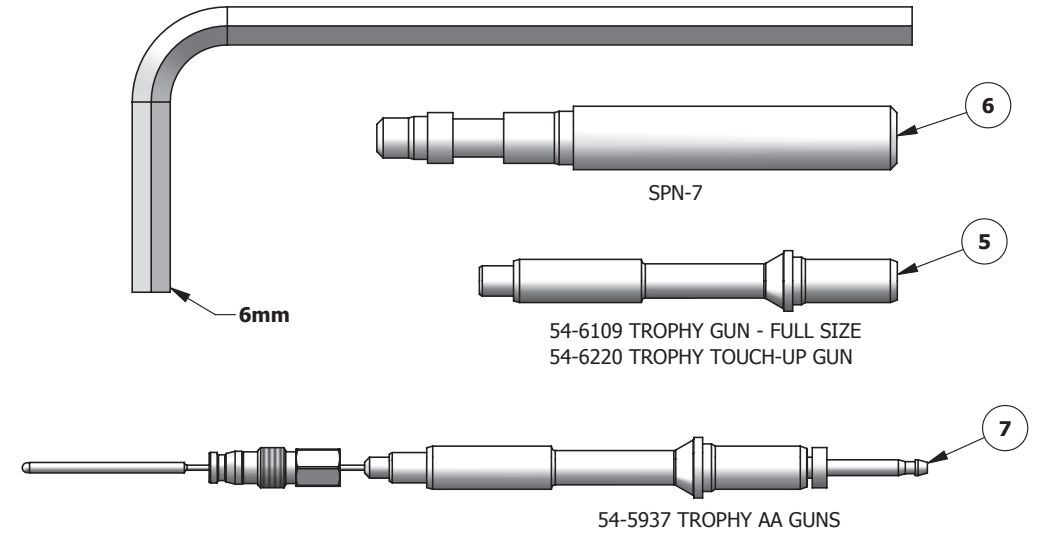
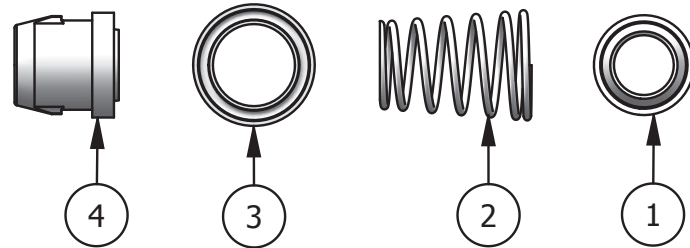

E CAUTION

Before dismantling the spray gun, turn off air and coating supply and relieve pressure in the supply line, or if using QD system, disconnect from air line and fluid line.
All parts on spray gun should be screwed in hand tight at first; this will avoid the possibility of cross-threading the parts. If the parts cannot be turned by hand easily, make sure you have the correct parts, unscrew, realign, and try again. NEVER use undue force in mating parts.
Never use 1,1,1-trichloroethane, methylene chloride, other halogenated hydrocarbon solvents or fluids containing such solvents in equipment with aluminum wetted parts. Such use could result in a serious chemical reaction, with the possibility of explosion. Consult your fluid suppliers to ensure that the fluids being used are compatible with aluminum parts.

ES PRECAUCIÓN

Antes de desmontar la pistola pulverizadora, interrumpa el suministro de aire y del material de recubrimiento y reduzca la presión en las líneas de suministro o, si está usando el sistema de desconexión rápida, desconéctela de la línea de aire y de la línea de fluido.
Todas las partes de una pistola pulverizadora se deben enrosacar primero a mano para evitar roscar las partes equivocadas. Si las partes no se pueden enrosacar a mano con facilidad, asegúrese de tener las partes correctas, desenrosque, realínee y trate de nuevo. NUNCA use fuerza excesiva al acoplar las piezas.
Nunca use 1, 1,1-tricloroetano, cloruro de metileno, otros disolventes con hidrocarburos halogenados o fluidos que contengan dichos disolventes en equipos con piezas de aluminio humedecidas. Tales usos pueden producir una reacción química peligrosa con posibilidades de explosión. Consulte con sus proveedores de fluidos para asegurarse de que los fluidos que se vayan a usar sean compatibles con las piezas de aluminio.

F ATTENTION

Avant de démonter le pistolet pulvérisateur, éteindre les alimentations d'air et de revêtement, puis relâcher la pression dans la conduite d'alimentation, ou si vous utilisez un système QD, déconnectez les lignes d'air et de liquide.
Toutes les parties du pistolet pulvérisateur doivent d'abord être vissées à la main et bien serrées ; ceci évitera la possibilité de fausser le filetage des parties. Si les parties ne peuvent être tournées aisément à la main, assurez-vous que vous avez les bonnes parties, dévissez, réalignez et essayez à nouveau. Ne JAMAIS utiliser de force excessive pour forcer les parties à s'emboîter.
Ne jamais utiliser de 1,1,1-trichloréthylène, chlore de méthylène, ou tout autre solvant d'hydrocarbure hydrogéné ou liquide contenant de tels solvants sur les parties en aluminium mouillées. Une telle utilisation peut entraîner une grave réaction chimique, avec la possibilité d'explosion. Consulter votre revendeur de liquides pour vous assurer que les produits utilisés sont compatibles avec les parties en aluminium.

D VORSICHT

Vor dem Zerlegen der Sprühpistole die Luft- und Lackzufuhr ausschalten und den Druck in der Versorgungsleitung ablassen, oder wenn Sie ein QD-System verwenden, die Luft- und Flüssigkeitsleitung abziehen.
Alle Teile der Sprühpistole sollten zunächst handfest angezogen werden; dadurch wird ein Verkanten der Teile vermieden. Wenn die Teile nicht einfach per Hand zu drehen sind, müssen Sie zunächst sichergehen, dass Sie die richtigen Teile haben. Schrauben Sie die Teile wieder ab und versuchen Sie es erneut. NIEMALS Gewalt auf die Kontaktflächen anwenden.
Verwenden Sie kein 1,1,1-Trichlormethan oder andere Lösungsmittel auf Kohlenwasserstoffbasis, oder Flüssigkeiten, die diese Lösungsmittel enthalten, für mit Aluminium beschichtete Teile. Die Folge könnte eine gefährliche chemische Reaktion oder sogar eine Explosion sein. Wenden Sie sich an Ihren Flüssigkeitslieferanten, um sicherzugehen, dass die verwendeten Flüssigkeiten mit Aluminiumteilen verwendet werden können.

IT ATTENZIONE

Prima di smontare la pistola a spruzzo, disattivare l'erogazione dell'aria e del sottostrato e ridurre la pressione nella linea di erogazione, o se si usa il sistema a disconnessione rapida, disconnettere dalla linea dell'aria e dalla linea del fluido.
Tutte le parti sulla pistola a spruzzo devono essere prima avvitate bene a mano; in questo modo si evita il rischio di avvitemento incrociato delle parti. Se le parti non possono essere girate a mano facilmente, verificare di avere le parti corrette, svitare, riallineare e riprovare. NON applicare MAI forza eccessiva nell'unire le parti.
Non usare mai 1,1,1-tricloroetano, cloruro di etilene, altri solventi a base di idrocarburo alogenato o fluidi che contengono simili solventi in utensili con parti di alluminio bagnate, per evitare il rischio di una seria reazione chimica con la possibilità di esplosione. Consultare il fornitore del fluido per verificare che i fluidi usati siano compatibili con le parti di alluminio.

中文 注意

拆卸喷枪前，阻隔空气与涂料的接触，并释放涂料管路中压力，如使用QD系统，请断开空气管路和流体管路的连接。
喷枪上的所有零件应先拧紧，避免螺纹错扣。如果零件不易用手转动，确保您使用的是正确的零件，拧开、调整并再试一次。不要在零配件上使用过度的力。
1,1,1-三氯乙烷，二氯甲烷，其他卤化烃溶剂或含有上述溶剂的液体不可用于含铝制漆液部件的设备。该操作可能会导致严重的化学反应，并可能引发爆炸。请咨询您的供应商以确保所用液体与铝制零件相兼容。

Carlisle Fluid Technologies is a global leader in innovative finishing technologies. Carlisle Fluid Technologies reserves the right to modify equipment specifications without prior notice.

DeVilbiss®, Ransburg®, ms®, BGK®, and Binks® are registered trademarks of Carlisle Fluid Technologies, Inc.

©2018 Carlisle Fluid Technologies, Inc. All rights reserved.

For technical assistance or to locate an authorized distributor, contact one of our international sales and customer support locations.

Region	Industrial / Automotive	Automotive Refinishing
Americas	Tel: 1-800-992-4657 Fax: 1-888-246-5732	Tel: 1-800-445-3988 Fax: 1-800-445-6643
Europe, Africa, Middle East, India	Tel: +44 (0)1202 571 111 Fax: +44 (0)1202 573 488	
China	Tel: +8621-3373 0108 Fax: +8621-3373 0308	
Japan	Tel: +81 45 785 6421 Fax: +81 45 785 6517	
Australia	Tel: +61 (0) 2 8525 7555 Fax: +61 (0) 2 8525 7575	

For the latest information about our products, visit www.carlisleleft.com

STANDARD TROPHY (FULL SIZE & TOUCHUP)

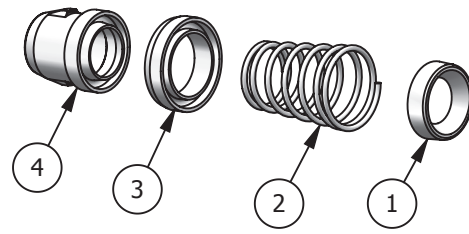
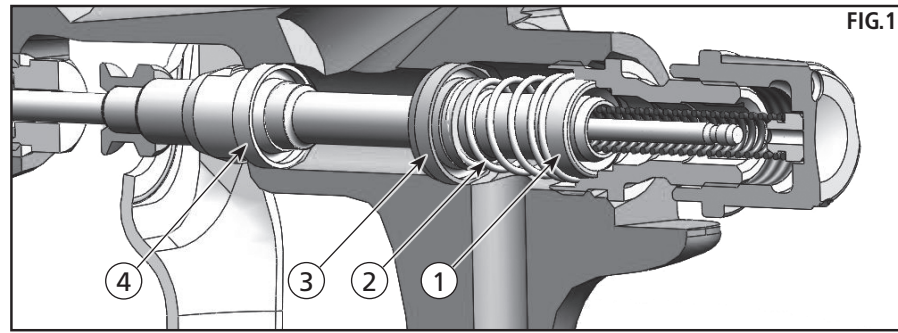

TROPHY AA (AIR ASSIST)

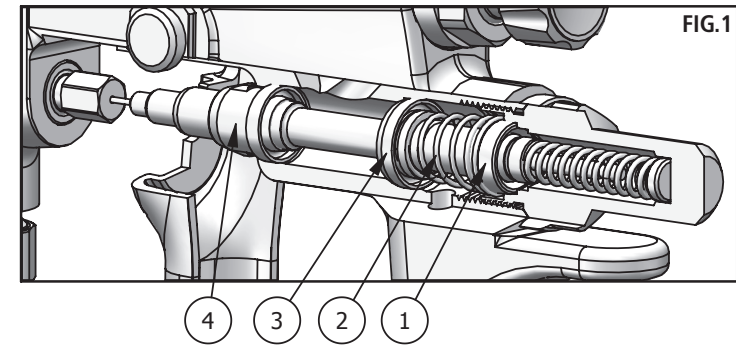

DISASSEMBLY DEENSAMBLAJE / DÉSAMBLAGE / ZERLEGEN / SMONTAGGIO 拆除

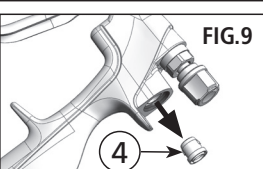
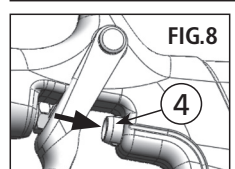
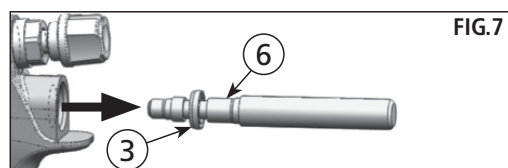
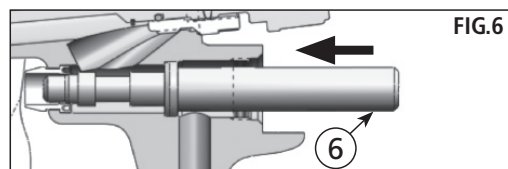
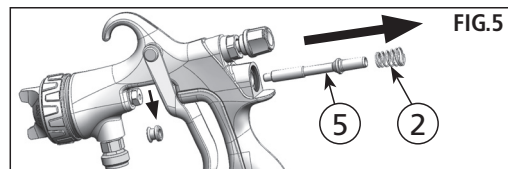
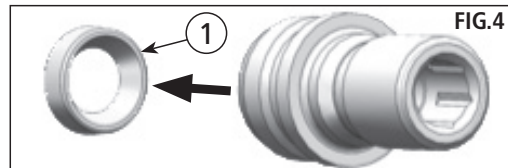
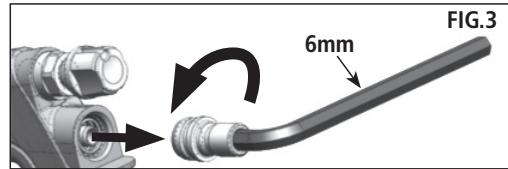
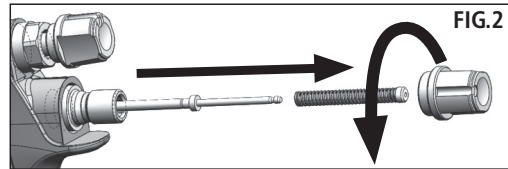

ASSEMBLY ENSAMBLAJE / ASSEMBLAGE / ZUSAMMENBAU / MONTAGGIO 安装

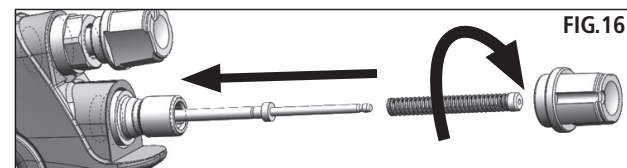
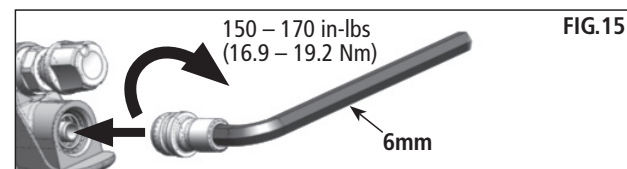
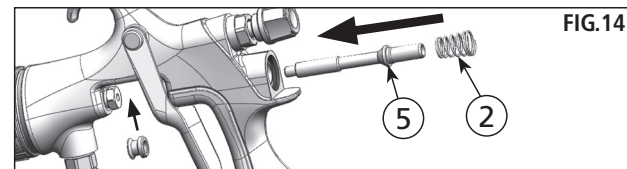
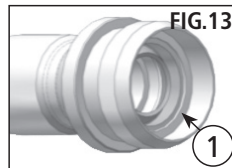
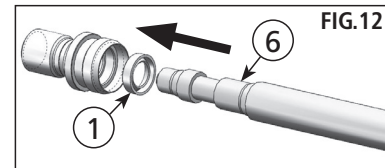
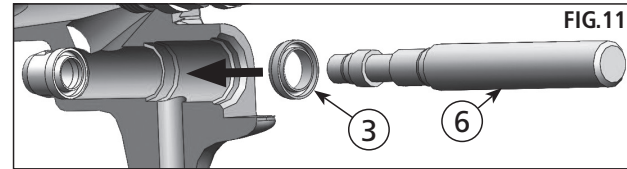
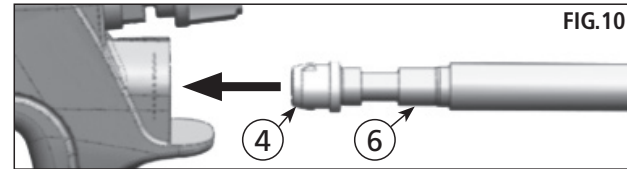

DISASSEMBLY DEENSAMBLAJE / DÉSAMBLAGE / ZERLEGEN / SMONTAGGIO 拆除

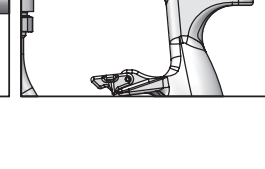
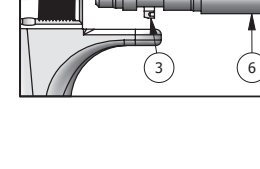
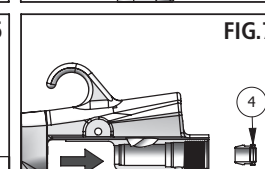
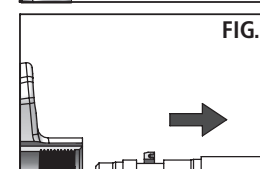
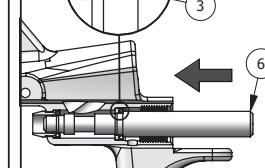
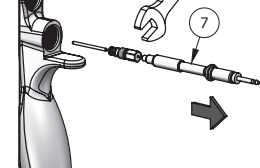
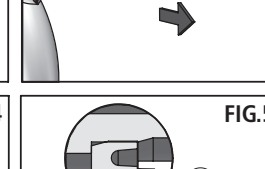
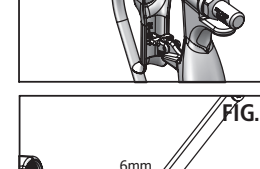
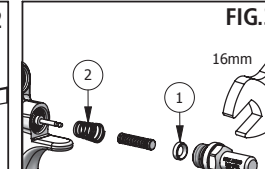
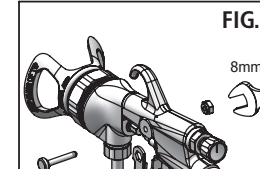

ASSEMBLY ENSAMBLAJE / ASSEMBLAGE / ZUSAMMENBAU / MONTAGGIO 安装

