



"TROPHY" SERIES MANUAL SPRAY GUNS

GRAVITY FEED HVLP, LVMP & CONVENTIONAL

(2466-XXXX-XXXX)



Binks Trophy Series Gravity Spray Gun is the premier spray gun for use in gravity feed spray applications and sets a new standard in durability, ergonomics, and atomization. The lightweight ergonomic design offers unsurpassed comfort and control. The latest advanced atomization technology has been incorporated for achieving consistent, fine finishes when spraying a wide range of industrial coating applications.

Binks Trophy Series Gravity Spray Guns are offered in three different atomization technologies: HVLP, LVMP and Conventional.



SPECIFICATIONS

Maximum Air Pressure	140 psi / 9.6 bar (P-1)
Gun Body	Anodized Aluminum
Fluid Path	Stainless Steel
Fluid Inlet Size	3/8" – 19 NPS / BSP(f)
Air Inlet Size	1/4" NPS / BSP(m)
Gun Weight	13.8 oz. / 394 grams (less cup)
Wetted Parts	Stainless Steel & PTFE

The Trophy HVLP Series of Spray Guns can be used to operate at high transfer efficiencies in compliance with "California South Coast Air Quality Management District" regulations as a High Volume, Low Pressure spray gun.

IMPORTANT! DO NOT DESTROY

It is the Customer's responsibility to have all operators and service personnel read and understand this manual.

READ ALL INSTRUCTIONS BEFORE OPERATING THIS PRODUCT.

In this part sheet, the words **WARNING**, **CAUTION** and **NOTE** are used to emphasize important safety information as follows:

WARNING

Hazards or unsafe practices which could result in severe personal injury, death or substantial property damage.

CAUTION

Hazards or unsafe practices which could result in minor personal injury, product or property damage.

NOTE

Important installation, operation or maintenance information.

WARNING

Read the following warnings before using this equipment.



READ THE MANUAL

Before operating finishing equipment, read and understand all safety, operation and maintenance information provided in the operation manual.



WEAR SAFETY GLASSES

Failure to wear safety glasses with side shields could result in serious eye injury or blindness.



DE-ENERGIZE, DEPRESSURIZE, DISCONNECT AND LOCK OUT ALL POWER SOURCES DURING MAINTENANCE

Failure to De-energize, disconnect and lock out all power supplies before performing equipment maintenance could cause serious injury or death.



OPERATOR TRAINING

All personnel must be trained before operating finishing equipment.



EQUIPMENT MISUSE HAZARD

Equipment misuse can cause the equipment to rupture, malfunction, or start unexpectedly and result in serious injury.



KEEP EQUIPMENT GUARDS IN PLACE

Do not operate the equipment if the safety devices have been removed.

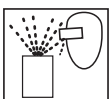

PROJECTILE HAZARD

You may be injured by venting liquids or gases that are released under pressure, or flying debris.



PINCH POINT HAZARD

Moving parts can crush and cut. Pinch points are basically any areas where there are moving parts.



PACEMAKER WARNING

You are in the presence of magnetic fields which may interfere with the operation of certain pacemakers.



AUTOMATIC EQUIPMENT

Automatic equipment may start suddenly without warning.



INSPECT THE EQUIPMENT DAILY

Inspect the equipment for worn or broken parts on a daily basis. Do not operate the equipment if you are uncertain about its condition.



NEVER MODIFY THE EQUIPMENT

Do not modify the equipment unless the manufacturer provides written approval.



KNOW WHERE AND HOW TO SHUT OFF THE EQUIPMENT IN CASE OF AN EMERGENCY



PRESSURE RELIEF PROCEDURE

Always follow the pressure relief procedure in the equipment instruction manual.



NOISE HAZARD

You may be injured by loud noise. Hearing protection may be required when using this equipment.



HIGH PRESSURE CONSIDERATION

High pressure can cause serious injury. Relieve all pressure before servicing. Spray from the spray gun, hose leaks, or ruptured components can inject fluid into your body and cause extremely serious injury.



STATIC CHARGE

Fluid may develop a static charge that must be dissipated through proper grounding of the equipment, objects to be sprayed and all other electrically conductive objects in the dispensing area. Improper grounding or sparks can cause a hazardous condition and result in fire, explosion or electric shock and other serious injury.

IT IS THE RESPONSIBILITY OF THE EMPLOYER TO PROVIDE THIS INFORMATION TO THE OPERATOR OF THE EQUIPMENT. FOR FURTHER SAFETY INFORMATION REGARDING THIS EQUIPMENT, SEE THE GENERAL EQUIPMENT SAFETY BOOKLET (77-5300).

BINKS "TROPHY" SERIES GRAVITY SPRAY GUN

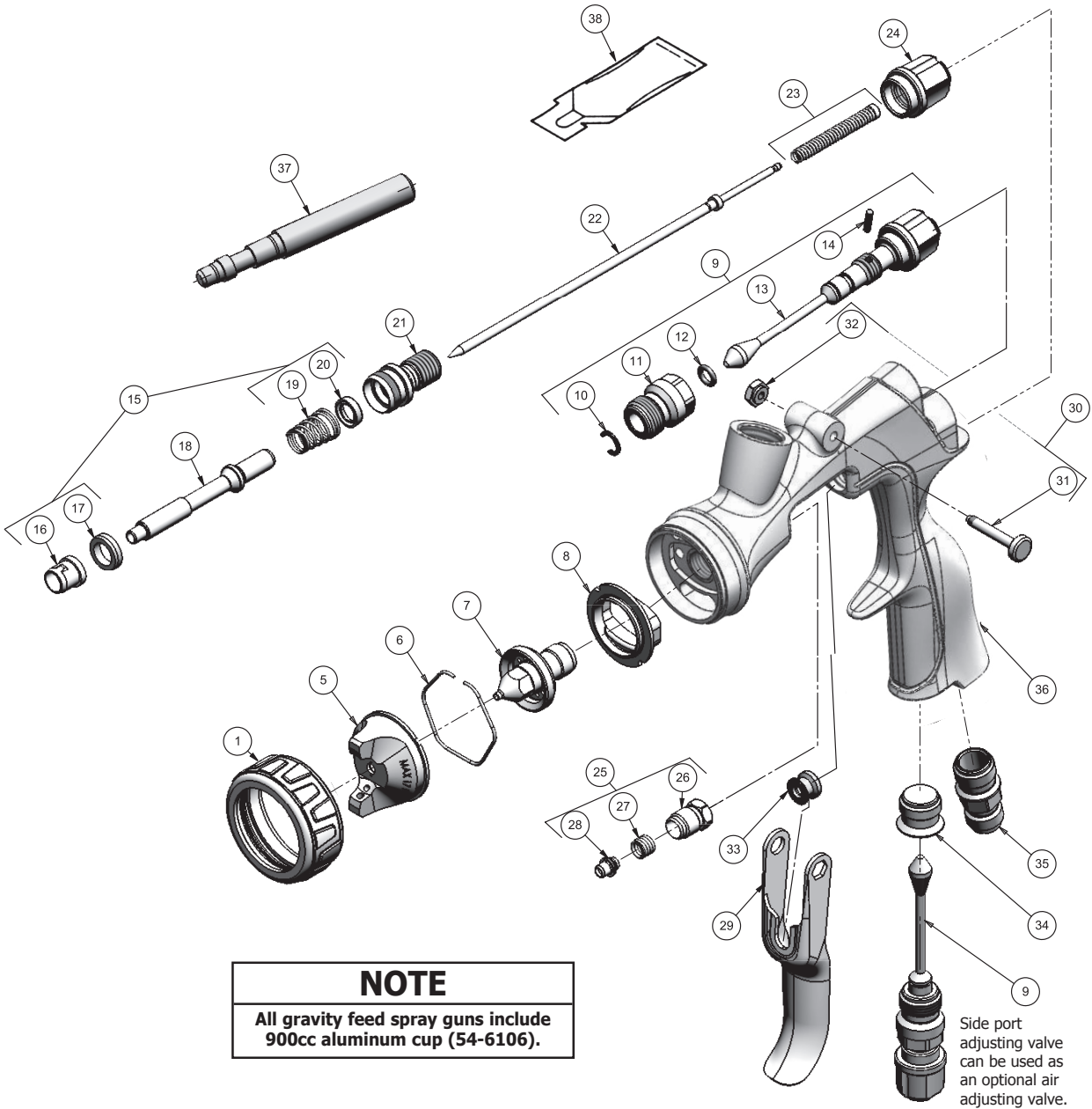

NOTE
 All gravity feed spray guns include 900cc aluminum cup (54-6106).

Side port adjusting valve can be used as an optional air adjusting valve.

NUMBERING SYSTEM FOR FULL SIZE BINKS "TROPHY" SERIES GRAVITY SPRAY GUNS

2466 – XXXX – XXXX

GRAVITY FEED GUN

ORIFICE SIZES

- 12 1.2 MM
- 14 1.4 MM
- 16 1.6 MM
- 18 1.8 MM

ATOMIZATION TECHNOLOGY

- CN CONVENTIONAL
- LV LVMP
- HV HVLP

CUP DESIGNATION

- 0 NO CUP
- G GRAVITY CUP

NEEDLE MATERIAL

- S STAINLESS (HARDENED)

AIR CAP DESIGNATION

- 10 Series CONVENTIONAL
- 20 Series LVMP
- 30 Series HVLP

See charts on page 7 for complete gun assemblies.

CHART 1: BINKS "TROPHY" SERIES GRAVITY SPRAY GUN PARTS LIST

ITEM NO.	PART NUMBER	DESCRIPTION	QTY.	ITEM NO.	PART NUMBER	DESCRIPTION	QTY.
1	54-6120	AIR CAP RETAINING RING ASSEMBLY	1	22	47-6825	NEEDLE – STAINLESS STEEL (STD.)	1
5	SEE CHARTS ON PAGE 7	AIR CAP	1	23	-----	☐ SPRING/PAD ASSEMBLY	1
6	JGA-156-K10	SPRING-CLIP (KIT OF 10)	1		54-6133-K3	SPRING/PAD ASSEMBLY (KIT OF 3)	1
7	SEE CHARTS BELOW	FLUID NOZZLE	1	24	54-6111	KNOB – NEEDLE ADJUSTING	1
8	54-6102-K3	BAFFLE/SEPARATOR (KIT OF 3)	1	25	54-6130-K	NEEDLE PACKING KIT (STANDARD)	1
9	54-6122	SIDE PORT VALVE ASSEMBLY	1	26	-----	■ NUT – PACKING	1
10	-----	+ Δ RETAINING CLIP	1	27	-----	■ SPRING FOR PACKING	1
11	-----	+ BODY BUSHING	1	28	-----	☐ NEEDLE PACKING (STANDARD)	1
12	-----	+ Δ O-RING	1		29	54-4360	TRIGGER
13	-----	+ SIDE PORT STEM	1	30	54-6132-K	TRIGGER SCREW NUT KIT	1
14	-----	+ Δ PIN	1	31	-----	* TRIGGER SCREW	1
15	54-6131-K	☐ AIR VALVE SERVICE KIT	1	32	-----	* TRIGGER NUT	1
16	-----	• FRONT SEAL – AIR VALVE	1	33	54-3513	SPINDLE CAP	1
17	-----	• FRONT AIR VALVE SEAL	1	34	SN-11	PLUG	1
18	54-6109	☐ AIR VALVE SPINDLE	1	35	54-6112	FITTING – AIR INLET	1
19	-----	• AIR VALVE SPRING	1	36	-----	GUN BODY WITH FLUID INLET	1
20	-----	• REAR SEAL – AIR VALVE	1	37	SPN-7	TOOL – SEAL INSERTION	1
21	SN-66	HOUSING	1	38	-----	GUNNER'S MATE (3 CC BAG)	1

+	PARTS INCLUDED IN 54-6122
■	PARTS INCLUDED IN 54-6130-K
▼	ALSO AVAILABLE IN KIT OF 3 SN-2-K3
•	PARTS INCLUDED IN 54-6131-K

*	PARTS INCLUDED IN 54-6132-K
Δ	GTI-428-K5 SIDE PORT REPAIR KIT
☐	PARTS INCLUDED IN 54-6135

**CHART 2:
STAINLESS STEEL (HARDENED)
FLUID NOZZLES – STD.**

STAINLESS FLUID NOZZLE ORIFICE SIZE		FLUID NOZZLE PART NUMBER
.039"	1.0 mm	45-11050-10
.047"	1.2 mm	45-11050-12
.055"	1.4 mm	45-11050-14
.063"	1.6 mm	45-11050-16
.071"	1.8 mm	45-11050-18

**CHART 3:
TEST AIR CAP KITS –
OPTIONAL**

CONVENTIONAL	
54-6141-K	12-C KIT
LVMP	
54-6147-K	23-L KIT
HVLP	
54-6152-K	32-H KIT – HVLP

BINKS "TROPHY" SERIES GRAVITY SPRAY GUN NEEDLE AND NOZZLE SELECTION GUIDE

CHART 4: CONVENTIONAL GUN SET-UPS

TYPE OF FLUID TO BE SPRAYED	COMPLETE GUN ASSEMBLY PART NUMBER	FLUID NOZZLE AND AIR CAP
THIN 5-25 CENTIPOISE 15-19 sec. Zahn 2 cup wash primers, dyes, stains, solvents, water, inks, sealers, laquers, lubricants, zinc chromates, acrylics	2466-14CN-12SG	1.4 mm (.055") X 12C
	2466-16CN-12SG	1.6 mm (.063") X 12C
MEDIUM 25-70 CENTIPOISE 20-30 sec. Zahn 2 cup synthetic enamels, varnishes, shellacs, fillers, primers, epoxies, urethanes, lubricants, wax emulsions, enamels	2466-16CN-12SG	1.6 mm (.063") X 12C
	2466-18CN-12SG	1.8 mm (.070") X 12C

CHART 5: LVMP GUN SET-UPS

TYPE OF FLUID TO BE SPRAYED	COMPLETE GUN ASSEMBLY PART NUMBER	FLUID NOZZLE AND AIR CAP
THIN 5-25 CENTIPOISE 15-19 sec. Zahn 2 cup wash primers, dyes, stains, solvents, water, inks, sealers, laquers, lubricants, zinc chromates, acrylics	2466-12LV-23SG	1.2 mm (.067") X 23L
	2466-14LV-23SG	1.4 mm (.055") X 23L
MEDIUM 25-70 CENTIPOISE 20-30 sec. Zahn 2 cup synthetic enamels, varnishes, shellacs, fillers, primers, epoxies, urethanes, lubricants, wax emulsions, enamels	2466-14LV-23SG	1.4 mm (.055") X 23L
	2466-18LV-23SG	1.8 mm (.070") X 23L

CHART 6: HVLP GUN SET-UPS

TYPE OF FLUID TO BE SPRAYED	COMPLETE GUN ASSEMBLY PART NUMBER	FLUID NOZZLE AND AIR CAP
THIN 5-25 CENTIPOISE 15-19 sec. Zahn 2 cup wash primers, dyes, stains, solvents, water, inks, sealers, laquers, lubricants, zinc chromates, acrylics	2466-12HV-32SG	1.2 mm (.047") X 32H
	2466-14HV-32SG	1.4 mm (.055") X 32H
MEDIUM 25-70 CENTIPOISE 20-30 sec. Zahn 2 cup synthetic enamels, varnishes, shellacs, fillers, primers, epoxies, urethanes, lubricants, wax emulsions, enamels	2466-14HV-32SG	1.4 mm (.055") X 32H
	2466-18HV-32SG	1.8 mm (.070") X 32H

BINKS "TROPHY" SERIES GRAVITY SPRAY GUN AIR CAP AND FLUID NOZZLE SELECTION CHARTS

CHART 7: CONVENTIONAL AIR CAP AND FLUID NOZZLE SELECTION CHART

Air Cap	Air Cap Part No.	Spray Pattern Range	CFM @ 30 PSI	CFM @ 50 PSI	CFM @ 70 PSI	Fluid Nozzle	Typical Coatings
12-C	46-6501	4 – 12"	8.3	12.1	14.2	45-11050 series, 1.2 mm – 1.8 mm	Lacquers, Enamels, Top Coats, Low Viscosity Adhesives

CHART 8: LVMP – LOW VOLUME MEDIUM PRESSURE AIR CAP AND FLUID NOZZLE SELECTION CHART

Air Cap	Air Cap Part No.	Spray Pattern Range	CFM @30 PSI Gun Inlet (Dynamic)	Fluid Nozzle	Typical Coatings
23-L	46-6511	4 – 12"	10.6	45-11050 series, 1.2 mm – 1.8 mm	Lacquers, Enamels, Top Coats, Low Viscosity Adhesives
24-L	46-6512	2 – 6"	14.3	45-11050 series, 1.0 mm – 1.8 mm	Small Pattern Applications of Stains, Lacquers, Enamels, Acrylics

CHART 9: HVLP – HIGH VOLUME LOW PRESSURE AIR CAP AND FLUID NOZZLE SELECTION CHART

Air Cap	Air Cap Part No.	Spray Pattern Range	SCFM @ 10 PSI Cap Pressure (Dynamic)	Gun Inlet PSI @ 10 PSI at Air Cap (Dynamic)	Fluid Nozzle	Typical Coatings
32-H	46-6518	8 – 14"	18.5	24	45-11050 series, 1.2 mm – 1.8 mm	Lacquers, Enamels, Multi-Colors, Multi-Spec, Nonstick Coatings, Cut-Latex

CHART 10: ROUND SPRAY AIR CAP AND FLUID NOZZLE SELECTION CHART (OPTIONAL)

Air Cap	Air Cap Part No.	Spray Pattern Range	CFM @ 30 PSI	CFM @ 50 PSI	CFM @ 70 PSI	Fluid Nozzle	Typical Coatings
16	46-6505	2 – 4"	5.6	7.8	10.5	45-11050 series, 1.2 mm – 1.8 mm	Lacquers, Enamels

TYPES OF INSTALLATION

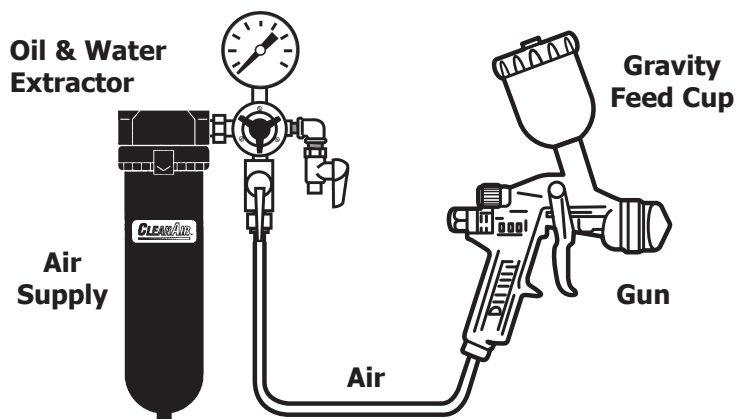

Air pressure for atomization is regulated at the extractor. The flow of the fluid is adjusted by the fluid valve control knob on gun, viscosity of paint and air pressure.

GRAVITY FEED HOOKUP

On gravity-feed spray guns the cup is located above the gun. The force of gravity pushes the fluid into the gun.

Advantages: this method offers quick color changes and convenience on small jobs or touch-up applications. Gravity spray guns are able to use all of the coating—reducing waste.

AIR PRESSURE

Atomizing pressure must be set properly to allow for the drop in air pressure between the regulator and the spray gun.

WITH 60 PSI APPLIED AT AIR SUPPLY

Cross section view showing comparison of inside hose diameters (actual size).
60 lbs. regulated pressure



5/16"

RECOMMENDED

48 PSI at gun inlet
25 feet of 5/16" I.D. hose causes a drop of 12 PSI between the air supply and the gun. For this reason Binks recommends the use of 5/16" hose.



1/4"

NOT RECOMMENDED

Only 34 PSI at gun inlet
25 feet of 1/4" I.D. hose causes a drop of 26 PSI between the air supply and the gun.

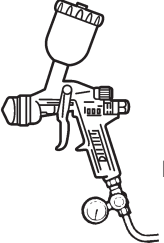

An oil and water extractor is important.

Achieving a fine spray finish without the use of a good oil and water extractor is virtually impossible.

A regulator/extractor serves a double purpose. It eliminates blistering and spotting by keeping air free of oil and water, and it gives precise air pressure control at the gun.

Use DeVilbiss oil and water extractors and regulators. See your local distributor for models.

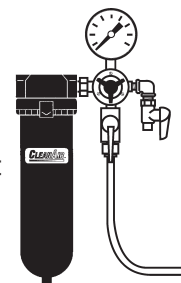

INSTALLATION INSTRUCTIONS

For maximum transfer efficiency, do not use more pressure than is necessary to atomize the material being applied.

NOTE

When using HVLP do not exceed inlet pressures listed on page 7.

1. Connect the gun to a clean, moisture and oil free air supply using a conductive hose of at least 5/16 in I.D.

NOTE

Depending on hose length, larger I.D. hose may be required. Install an air gauge at the gun handle. See page 7 for operating pressures. Do not use more pressure than is necessary to atomize the material being applied. Excess pressure will create additional overspray and reduce transfer efficiency.

NOTE

If quick connect couplings are required, use only high flow quick connects approved for HVLP use. Other types will not flow enough air for correct gun operation.

NOTE

If an air adjusting valve is used at the gun inlet, use HAV-501 adjusting valve.

NOTE

Before using the spray gun, flush it with solvent to ensure that the fluid passages are clean.

OPERATION

GRAVITY MODELS

1. Mix coating material to manufacturer's instructions and strain material.
2. Fill the cup to no more than 3/4 inch from the top of the cup. DO NOT OVERFILL.
3. Attach to cup lid.
4. Turn fluid adjusting knob (24) clockwise to prevent fluid needle movement.
5. Turn sideport control (9) counter clockwise to fully open.
6. Adjust inlet air pressure if required.
7. Turn fluid adjusting knob counter clockwise until first thread shows.

8. Test spray. If the finish is too dry, reduce airflow by reducing air inlet pressure.
9. If finish is too wet, reduce fluid flow by turning fluid adjusting knob (24) clockwise. If atomization is too coarse, increase inlet air pressure. If too fine, reduce inlet pressure.
10. The pattern size can be reduced by turning sideport control (9) clockwise.
11. Hold gun perpendicular to surface being sprayed. Arcing or tilting may result in uneven coating.
12. The recommended spray distance is 8 inches.
13. Spray edges first. Overlap each stroke a minimum of 75%. Move gun at a constant speed.
14. Always turn off air supply and relieve pressure when gun is not in use.

PREVENTIVE MAINTENANCE AND CLEANING

To clean air cap and fluid nozzle, brush exterior with a stiff bristle brush. If necessary to clean cap holes, use a broom straw or toothpick if possible. If a wire or hard instrument is used, extreme care must be used to prevent scratching or burring of the holes which will cause a distorted spray pattern.

To clean fluid passages, remove excess material from gun, then flush with gun wash solution. Wipe the gun exterior with a dampened cloth. Never completely immerse in any solvent or cleaning solutions as this is detrimental to the lubricants and life of the spray gun.

NOTE

When replacing the fluid nozzle (7) or fluid needle (22), replace both at the same time. Using worn parts can cause fluid leakage. See page 4. Also, replace the needle packing at this time. Torque the fluid nozzle to 230–240 inch-lbs. Do not over tighten.

CAUTION

To prevent damage to fluid nozzle (7) or fluid needle (22), be sure to either 1) pull the trigger and hold while tightening or loosening the fluid nozzle, or 2) remove fluid adjusting knob (24) to relieve spring pressure against needle collar.

GRAVITY CUP. Empty excess material and clean the cup. Make sure the vent hole in the lid is clear.

REMOVAL AND INSTALLATION PROCEDURES

NEEDLE AND VALVE DISASSEMBLY AND ASSEMBLY

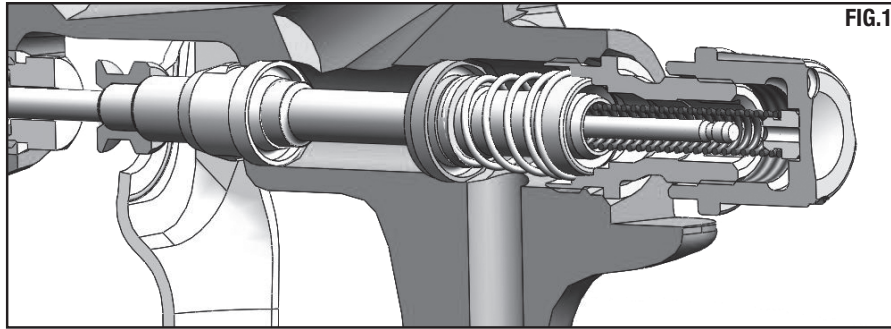

DISASSEMBLY

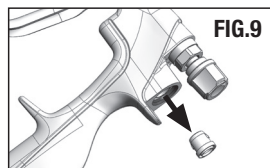
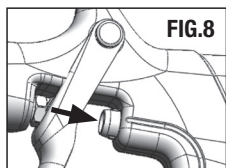
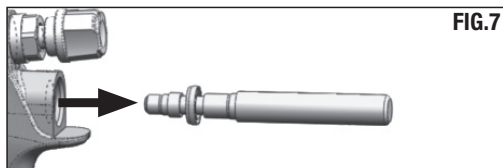
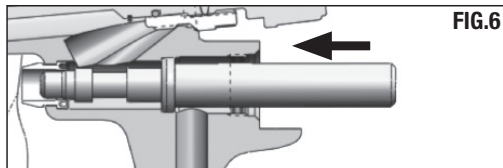
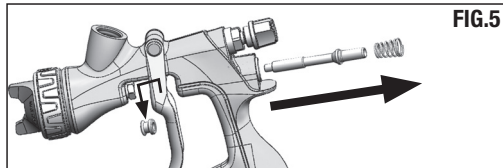
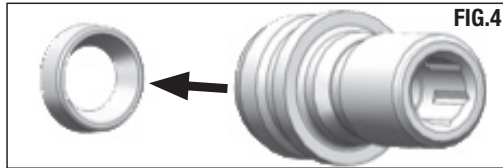
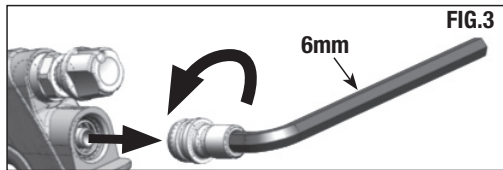
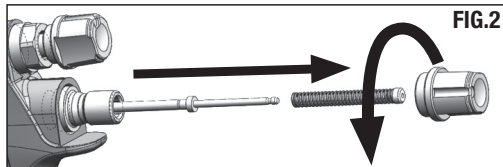

ASSEMBLY

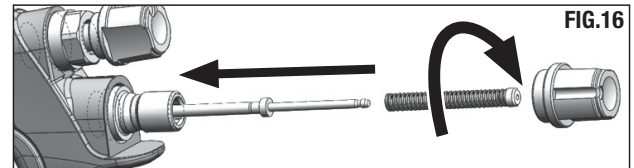
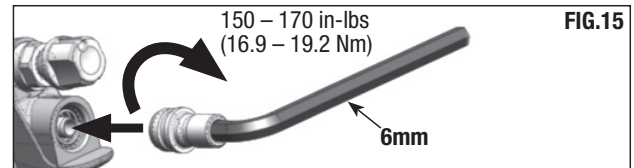
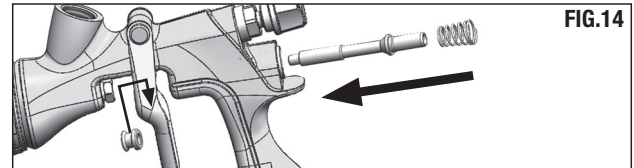
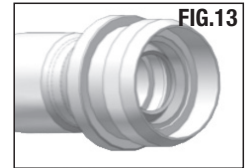
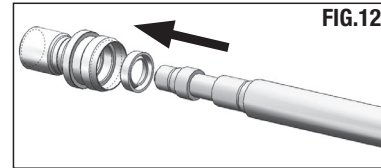
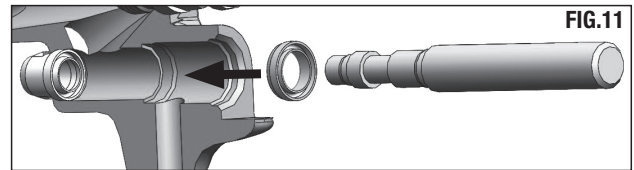
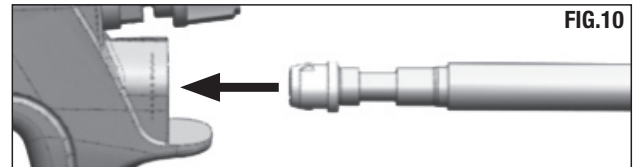

MAINTENANCE – FLUID NOZZLE AND BAFFLE REMOVAL AND INSTALLATION

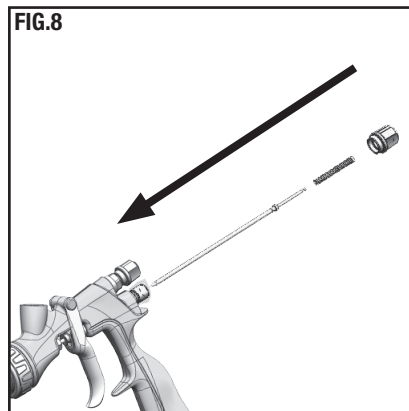
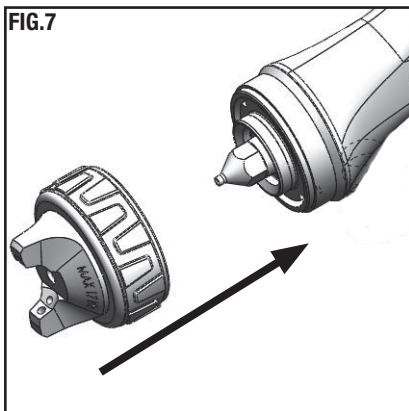
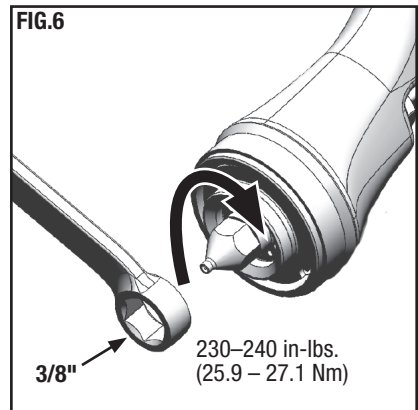
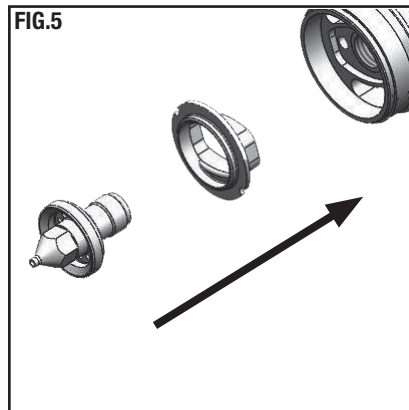
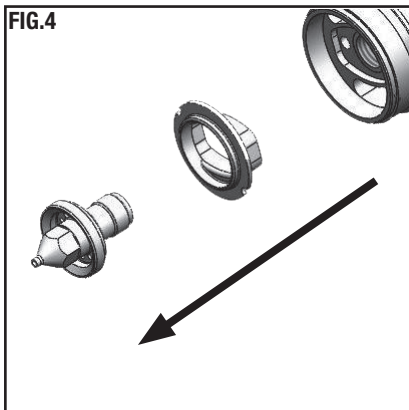
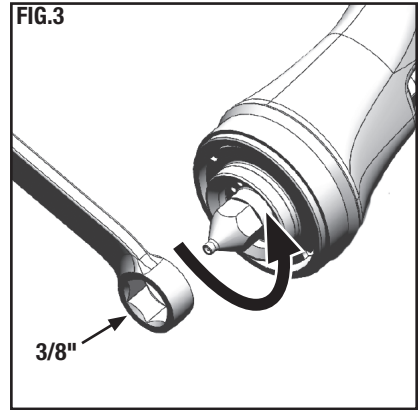
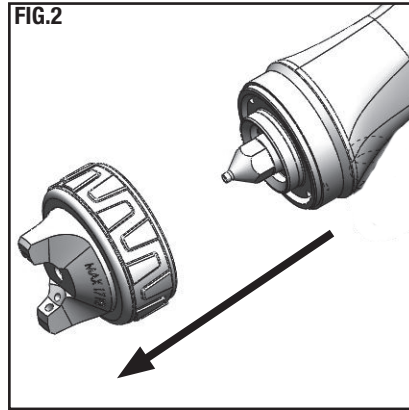
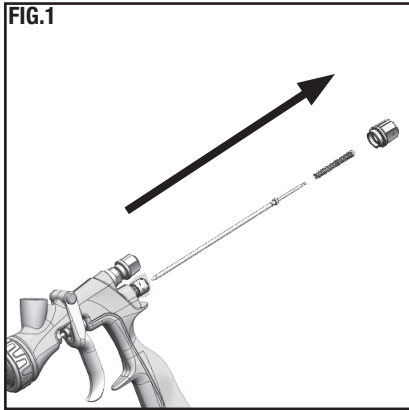

AIR CAP INDEX PIN (54-6184) INSTALLATION (OPTIONAL – 90° INCREMENTS INDEXING FEATURE)

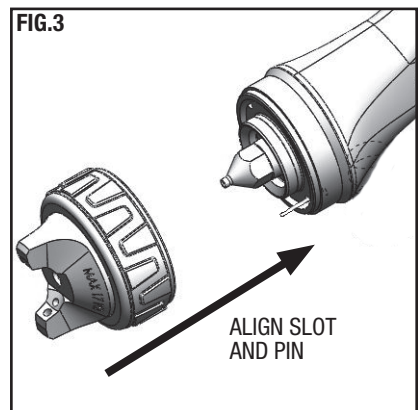
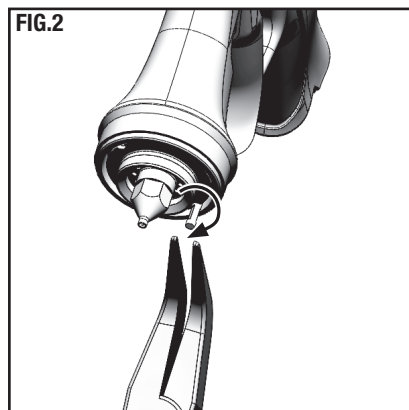
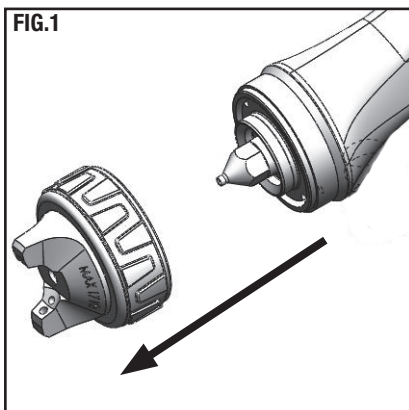



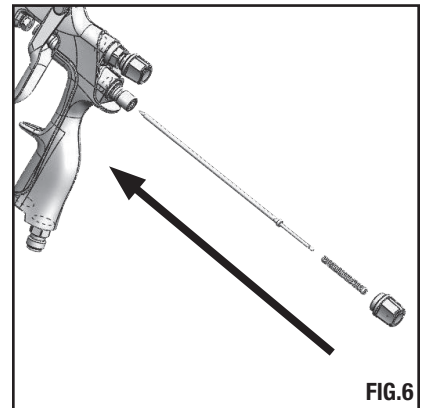
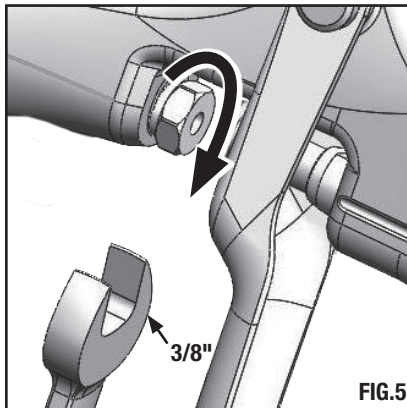
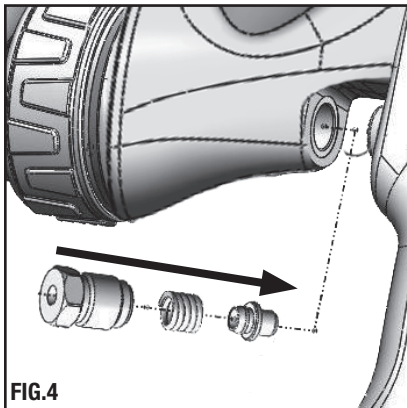
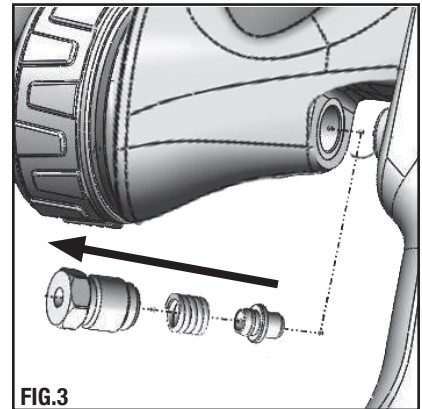
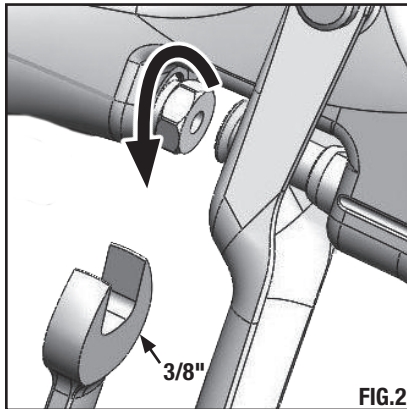
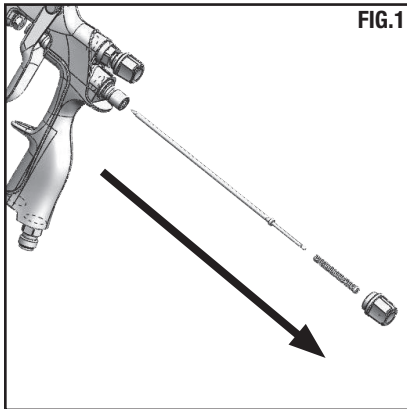

MAINTENANCE – NEEDLE PACKING REMOVAL AND INSTALLATION

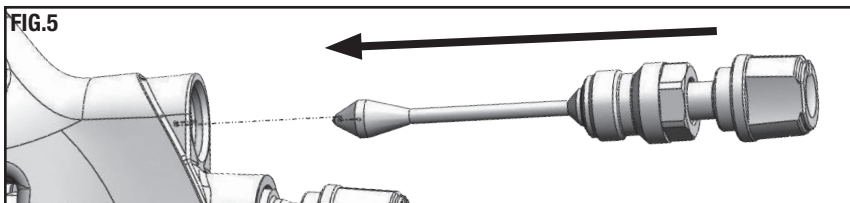
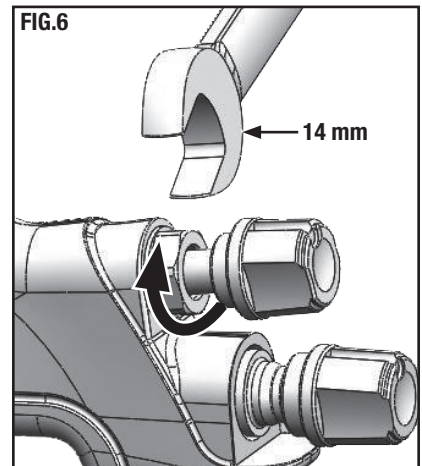
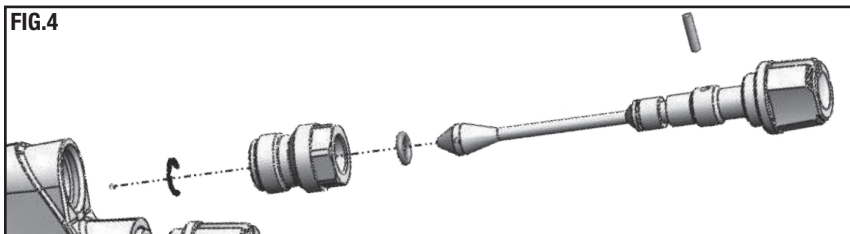
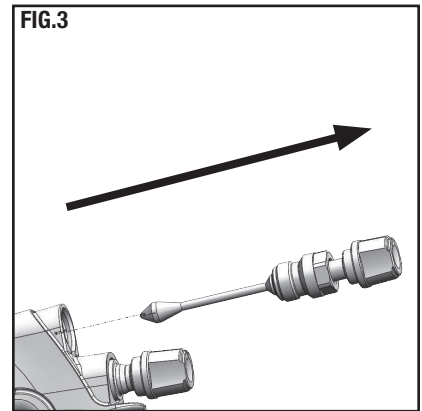
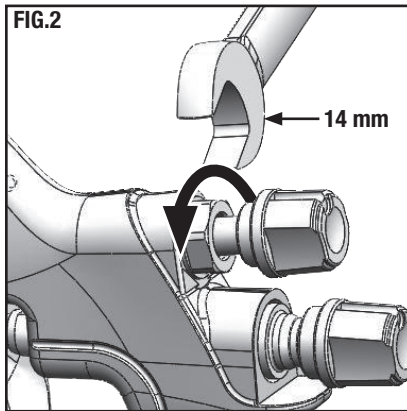
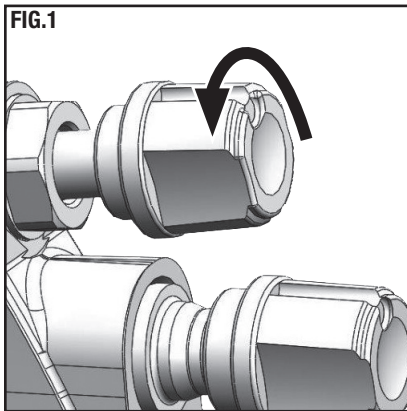

MAINTENANCE – SIDEPORT REMOVAL AND INSTALLATION



TROUBLESHOOTING

CONDITION	CAUSE	CORRECTION
Heavy top or bottom pattern 	Horn holes plugged. Obstruction on top or bottom of fluid tip. Cap and/or tip seat dirty.	Clean. Ream with non-metallic point. Clean. Clean.
Heavy right or left side pattern 	Left or right side horn holes plugged. Dirt on left or right side of fluid tip. Remedies for the top-heavy, bottom-heavy, right-heavy, and left-heavy patterns: 1. Determine if the obstruction is on the air cap or the fluid tip. Do this by making a test spray pattern. Then, rotate the cap one-half turn and spray another pattern. If the defect is inverted, obstruction is on the air cap. Clean the air cap as previously instructed. 2. If the defect is not inverted, it is on the fluid tip. Check for a fine burr on the edge of the fluid tip. Remove with #600 wet or dry sand paper. 3. Check for dried paint just inside the opening; remove by washing with solvent.	Clean. Ream with non-metallic point. Clean.
Heavy center pattern 	Fluid flow too high for atomization air. Material flow exceeds air cap's capacity. Spreader adjustment valve set too low. Atomizing pressure too low. Material too thick.	Balance air pressure and fluid flow. Increase spray pattern width with spreader adjustment valve. Thin or lower fluid flow. Adjust. Increase pressure. Thin to proper consistency.
Split spray pattern 	Atomization air pressure too high. Fluid flow too low. Spreader adjusting valve set too high.	Reduce at transformer or gun. Increase fluid flow (increases gun handling speed). Adjust.
Jerky or fluttering spray 	*Loose or damaged fluid tip/seat. Material level too low. Container tipped too far. Obstruction in fluid passage. Dry or loose fluid needle packing nut.	Tighten or replace. Refill. Hold more upright. Backflush with solvent. Lubricate or tighten.
Unable to get round spray	Spreader adjustment screw not seating properly. Air cap retaining ring loose.	Clean or replace. Tighten.
Will not spray	No air pressure at gun. Fluid needle adjusting screw not open enough. Fluid too heavy for gravity feed.	Check air supply and air lines, blow out gun air passages. Open fluid needle adjusting screw. Thin material and/or change to larger tip size.
Paint bubbles in cup	Fluid tip not tight.	Tighten tip.
Fluid leaking or dripping from cup lid	Cup lid loose. Dirty threads on cup or lid. Cracked cup or lid.	Tighten lid. Clean. Replace cup and lid.

*Most common problem.

TROUBLESHOOTING

CONDITION	CAUSE	CORRECTION
Starved spray pattern	Inadequate material flow. Low atomization air pressure.	Back fluid adjusting screw out to first thread, or change to larger tip size. Increase air pressure and rebalance gun.
Excessive overspray	Too much atomization air pressure. Gun too far from work surface. Improper stroking (arcing, gun motion too fast).	Reduce pressure. Adjust to proper distance. Move at moderate pace, parallel to work surface.
Excessive fog	Too much or too fast-drying thinner. Too much atomization (air pressure.)	Remix properly. Reduce air pressure.
Dry spray	Air pressure too high. Gun tip too far from work surface. Gun motion too fast. Gun out of adjustment.	Reduce air pressure. Adjust to proper distance. Slow down. Adjust.
Fluid leaking from packing nut	Packing nut loose. Packing worn or dry.	Tighten, do not bind needle. Replace or lubricate.
Fluid leaking or dripping from front of gun	Packing nut too tight. Dry packing. Fluid tip or needle worn or damaged. Foreign matter in tip. Fluid needle spring broken. Wrong size needle or tip.	Adjust. Lubricate. Replace tip and needle. Clean. Replace. Replace.
Fluid dripping or leaking from bottom of cup	Cup loose on gun. Cup gasket worn or missing below cup. Cup threads dirty.	Tighten. Replace cup gasket. Clean.
Runs and sags	Too much material flow. Material too thin. Gun tilted on an angle, or gun motion too slow.	Adjust gun or reduce fluid flow. Mix properly or apply light coats. Hold gun at right angle to work and adapt to proper gun technique.
Thin, sandy coarse finish drying before it flows out	Gun too far from surface. Too much air pressure. Improper thinner being used.	Check distance. Normally approximately 8". Reduce air pressure and check spray pattern. Follow paint manufacturer's mixing instructions.
Thick, dimpled finish "orange peel"	Gun too close to surface. Too much material coarsely atomized. Air pressure too low. Improper thinner being used. Material not properly mixed. Surface rough, oily, dirty.	Check distance. Normally approximately 8". Follow paint manufacturer's mixing instructions. Increase air pressure or reduce fluid flow. Follow paint manufacturer's mixing instructions. Follow paint manufacturer's mixing instructions. Follow paint manufacturer's mixing instructions. Properly clean and prepare.

ACCESSORIES

For additional accessory components including other suction cups options, disposable cup options, inlet quick disconnects, and cleaning kits please visit Carlisleleft.com.

NOTES

WARRANTY POLICY

This product is covered by Carlisle Fluid Technologies' materials and workmanship limited warranty. The use of any parts or accessories, from a source other than Carlisle Fluid Technologies, will void all warranties. Failure to reasonably follow any maintenance guidance provided may invalidate any warranty.

For specific warranty information please contact Carlisle Fluid Technologies.

For technical assistance or to locate an authorized distributor, contact one of our international sales and customer support locations.

Region	Industrial / Automotive	Automotive Refinishing
Americas	Tel: 1-800-992-4657 Fax: 1-888-246-5732	Tel: 1-800-445-3988 Fax: 1-800-445-6643
Europe, Africa, Middle East, India	Tel: +44 (0)1202 571 111 Fax: +44 (0)1202 573 488	
China	Tel: +8621-3373 0108 Fax: +8621-3373 0308	
Japan	Tel: +81 45 785 6421 Fax: +81 45 785 6517	
Australia	Tel: +61 (0) 2 8525 7555 Fax: +61 (0) 2 8525 7575	

For the latest information about our products, visit www.carlisleleft.com

Carlisle Fluid Technologies is a global leader in innovative finishing technologies. Carlisle Fluid Technologies reserves the right to modify equipment specifications without prior notice.

BGK™, Binks®, DeVilbiss®, Hosco®, MS®, and Ransburg® are all registered trademarks of Carlisle Fluid Technologies, LLC.

©2023 Carlisle Fluid Technologies, LLC.
All rights reserved.



16430 North Scottsdale Rd., Suite 450 Scottsdale, AZ 85254 USA