



MODEL 21, 21V, & 21M AUTOMATIC SPRAY GUN (6220-XXXX-X) (6235-XXXX-X) (6219-XXXX-X) BRASS BODY



The following instructions provide the necessary information for the proper operation and preventive maintenance of the Binks Model 21 Automatic Spray Gun. Please read and understand all information in this document in order to get the maximum performance from your new Model 21 spray gun.

All Model 21 spray guns feature nickel plated brass air caps and bodies that will withstand years of use under the toughest conditions. The Model 21V spray guns contain tungsten carbide fluid nozzles and needles for use with abrasive fluids. The Model 21M spray guns are internal mix spray guns used in line striping.

The Model 21 Series of spray guns are heavy duty, pneumatically operated, automatic spray guns with forged brass bodies.

SPECIFICATIONS:

Maximum Fluid Pressure:	100 psi/6.9 bar
Maximum Air Pressure:	100 psi/6.9 bar
Gun Body:	Plated Brass
Fluid Path:	Brass/Electroless Nickel Plated
Fluid Inlet Size:	3/8" NPS(m) Thread
Air Inlet Size:	1/4" NPS(m) Thread
Gun Weight:	41 oz./1213 g
Mounting Hole:	1/2"
Mounting Bracket:	54-380 (1/2" Bar)

IMPORTANT! DO NOT DESTROY

It is the Customer's responsibility to have all operators and service personnel read and understand this manual.

READ ALL INSTRUCTIONS BEFORE OPERATING THIS PRODUCT.

In this part sheet, the words **WARNING**, **CAUTION** and **NOTE** are used to emphasize important safety information as follows:

⚠ WARNING
 Hazards or unsafe practices which could result in severe personal injury, death or substantial property damage.

⚠ CAUTION
 Hazards or unsafe practices which could result in minor personal injury, product or property damage.

NOTE
 Important installation, operation or maintenance information.

⚠ WARNING

Read the following warnings before using this equipment.



READ THE MANUAL
 Before operating finishing equipment, read and understand all safety, operation and maintenance information provided in the operation manual.



WEAR SAFETY GLASSES
 Failure to wear safety glasses with side shields could result in serious eye injury or blindness.



DE-ENERGIZE, DEPRESSURIZE, DISCONNECT AND LOCK OUT ALL POWER SOURCES DURING MAINTENANCE
 Failure to De-energize, disconnect and lock out all power supplies before performing equipment maintenance could cause serious injury or death.



OPERATOR TRAINING
 All personnel must be trained before operating finishing equipment.



EQUIPMENT MISUSE HAZARD
 Equipment misuse can cause the equipment to rupture, malfunction, or start unexpectedly and result in serious injury.

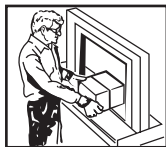

KEEP EQUIPMENT GUARDS IN PLACE
 Do not operate the equipment if the safety devices have been removed.

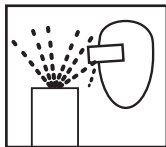

PROJECTILE HAZARD
 You may be injured by venting liquids or gases that are released under pressure, or flying debris.



PINCH POINT HAZARD
 Moving parts can crush and cut. Pinch points are basically any areas where there are moving parts.



AUTOMATIC EQUIPMENT
 Automatic equipment may start suddenly without warning.



INSPECT THE EQUIPMENT DAILY
 Inspect the equipment for worn or broken parts on a daily basis. Do not operate the equipment if you are uncertain about its condition.



NEVER MODIFY THE EQUIPMENT
 Do not modify the equipment unless the manufacturer provides written approval.



KNOW WHERE AND HOW TO SHUT OFF THE EQUIPMENT IN CASE OF AN EMERGENCY



PRESSURE RELIEF PROCEDURE
 Always follow the pressure relief procedure in the equipment instruction manual.



NOISE HAZARD
 You may be injured by loud noise. Hearing protection may be required when using this equipment.



HIGH PRESSURE CONSIDERATION
 High pressure can cause serious injury. Relieve all pressure before servicing. Spray from the spray gun, hose leaks, or ruptured components can inject fluid into your body and cause extremely serious injury.



STATIC CHARGE
 Fluid may develop a static charge that must be dissipated through proper grounding of the equipment, objects to be sprayed and all other electrically conductive objects in the dispensing area. Improper grounding or sparks can cause a hazardous condition and result in fire, explosion or electric shock and other serious injury.

IT IS THE RESPONSIBILITY OF THE EMPLOYER TO PROVIDE THIS INFORMATION TO THE OPERATOR OF THE EQUIPMENT.

FOR FURTHER SAFETY INFORMATION REGARDING BINKS AND DEVILBISS EQUIPMENT,
 SEE THE GENERAL EQUIPMENT SAFETY BOOKLET (77-5300).

BINKS MODEL 21 & 21V SERIES AUTOMATIC SPRAY GUN

HOOK-UP

1. Air pressure of 35-50 PSI minimum required for cylinder operation.
2. For rapid operation, the air line between three-way valve and the cylinder operating air connection should be as short as possible.
3. All air supplied to the gun should be dirt and moisture-free. A DeVilbiss centrifugal air filter mounted in the air supply line is recommended.
4. If the gun is to stand idle for any length of time, shut off. This will prevent small leaks throughout the system from turning on the gun.

FAN SPRAY ADJUSTMENTS

The fan spray is easily controlled by means of the side port control. Turning this control to the right, or clockwise, will give a round spray pattern. Turning it to the left, or counter-clockwise, will widen the spray into a fan shape of any desired width. Orientation of the fan spray either horizontally or vertically (or to any position in between) is obtained by loosening the retainer ring, rotating the air nozzle to the desired position, and then tightening the retainer ring.

FLUID FLOW ADJUSTMENTS

For best results, the fluid control screw (16) should be set at the open position and the flow of the fluid controlled by regulating the fluid pressure in the pressure tank. If the conditions under which the gun is being used require the fluid to be controlled at the gun, it may be accomplished by loosening locknut (17) and turning screw (16) to the right (clockwise) to decrease the flow of fluid or the left (counter-clockwise) to increase the flow of fluid.

LUBRICATION

The points that require lubrication on this gun are the plunger (7), the air valve packing (11), and the fluid packing (29). These parts should be kept soft and pliable at all times. SSL-10 gun lube is recommended for this.

⚠ CAUTION

Never submerge the gun in solvent. Solvent will wash the oil off the lubricated parts and cause subsequent malfunctioning of the gun.

CLEANING

Shut off the air supply to the tank and release its pressure. Hold a piece of wadded cloth over the gun nozzle and turn on the air to the cylinder. The air will back up through the fluid nozzle and force fluid out of the hose and into the tank.

Replace the paint in the pressure tank with clean solvent and flush through the material hose and spray gun until clean. Blow air through the fluid hose to eliminate residual solvent. Always follow EPA and NFPA regulations when spraying or cleaning spray equipment.

FAULTY SPRAY

Faulty spray is caused by dry coating material residue around the fluid nozzle tip or inside the air nozzle. Soak these parts in a solvent that will soften the dried residue until it can be removed with a brush or a cloth.

⚠ CAUTION

Never use metal probes to clean the air or fluid nozzles because scratches and burns on their precision machined surfaces can cause faulty spray. If either the air or fluid nozzle is damaged so as to give faulty spray, it must be replaced.

COMPLETE SPRAY GUN MODELS – ORDERING GUIDE

MODEL 21 SETUPS AVAILABLE		Application										Fluid Orifice			Pattern Size		
		Thin	Medium	Heavy	Very Heavy	Adhesives	Mold Release	Ceramics	Non-Stick Coating	Hammers	Zinc	Size (Inches)	Size (mm)	Max at 6"	CFM at 30 PSI	CFM at 50 PSI	CFM at 70 PSI
6220-2800-7	63BSS-63PB	■	■									0.046	1.2	14	9.0	14.3	20.0
6220-4307-9	66SS-66SD	■	■									0.070	1.8	10.5	7.9	12.1	15.5
6220-8118-5	59BSS-252			■								0.218	5.5	6	7.8	11.5	15.2
6220-2821-1	63BSS-21MD-1	■	■	■	■	■	■	■	■	■	■	0.046	1.2	14	8.5	12.3	15.9
6220-2821-3	63BSS-21MD-3	■	■	■	■	■	■	■	■	■	■	0.046	1.2	15	8.4	12.2	15.7
6220-4308-2	66SS-66SD-3	■	■	■	■	■	■	■	■	■	■	0.070	1.8	10	7.9	12.1	16.2
6220-5123-7	68SS-709SS	■	■	■	■	■	■	■	■	■	■	0.110	2.8	6	4.3	6.9	8.9
6220-8219-1	59CSS-262	■	■	■	■	■	■	■	■	■	■	0.281	7.1	6	7.3	11.0	14.7
6235-4921-2	67VT-21MD-2	■	■	■	■	■	■	■	■	■	■	0.086	2.2	17	9.6	14.0	18.1
6235-3206-3	63CVT-66PH	■	■	■	■	■	■	■	■	■	■	0.052	1.3	11	8.0	11.8	15.2
6235-4909-5	67VT-67PB	■	■	■	■	■	■	■	■	■	■	0.086	2.2	12	9.5	14.1	19.1
6219-8219-1	59CSS-262	Internal mix spray gun for line striping applications															

Model 21
 Model 21V
 Model 21M

New Setups
 Use for Line Striping

Note: 21 and 21V Gun spray patterns can be adjusted from round spray to maximum pattern size by the means of the side port adjustment.

BINKS MODEL 21 & 21V SERIES AUTOMATIC SPRAY GUN

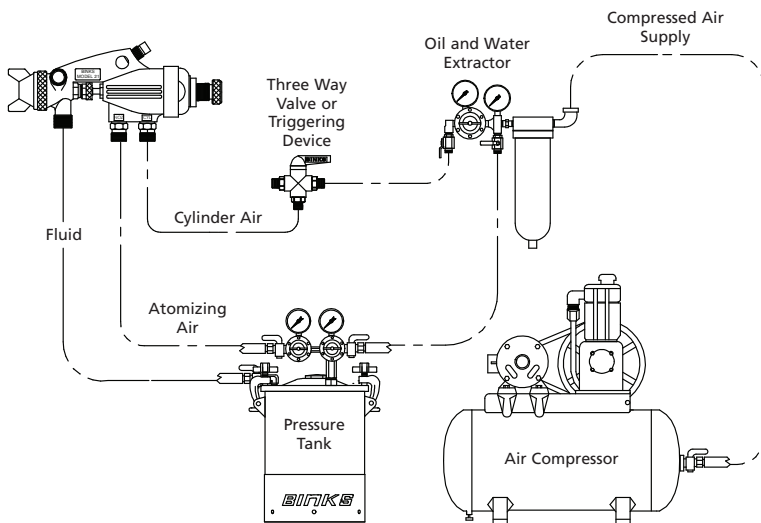
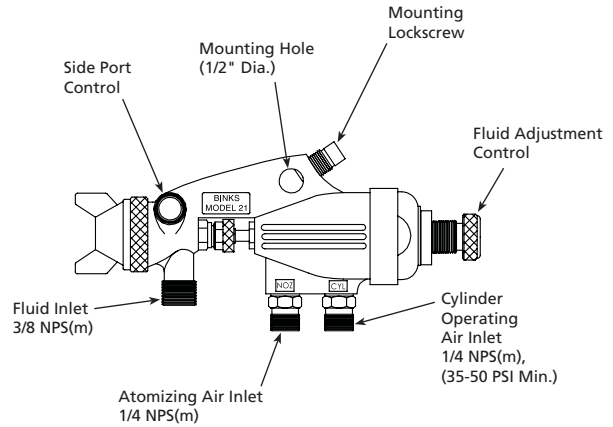
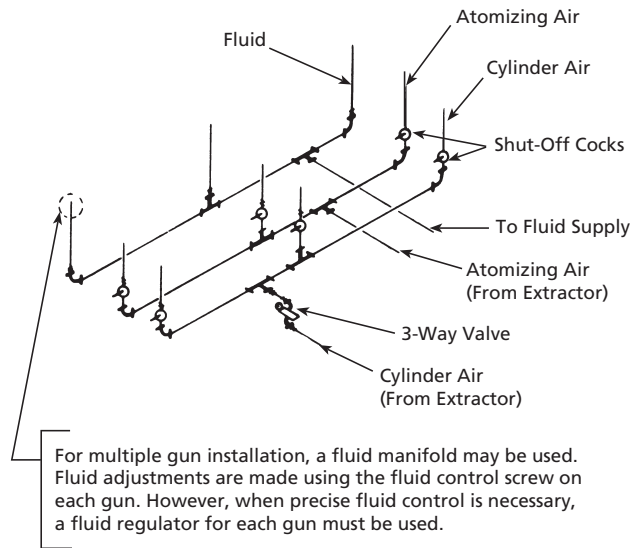

BINKS SPRAY GUN MODEL	CONNECTION THREADS SIZE	
	FLUID	AIR
21 SERIES	3/8 NPS	1/4 NPS

GENERAL NOTES

1. Have at least 35 PSI air pressure for cylinder operating air.
2. The air line from spray gun to 3-way valve should be as short as possible for rapid operation.
3. All air used in the spray gun should be dirt and moisture free. (This is accomplished by using a clean air filter.)
4. Shut off all fluid and air lines to spray gun if spray gun is to stand idle for any length of time. (This is to prevent "build-up" or accumulation of minute leaks in the system.)
5. Generally fluid hoses are 3/8" and air hoses are 1/4".

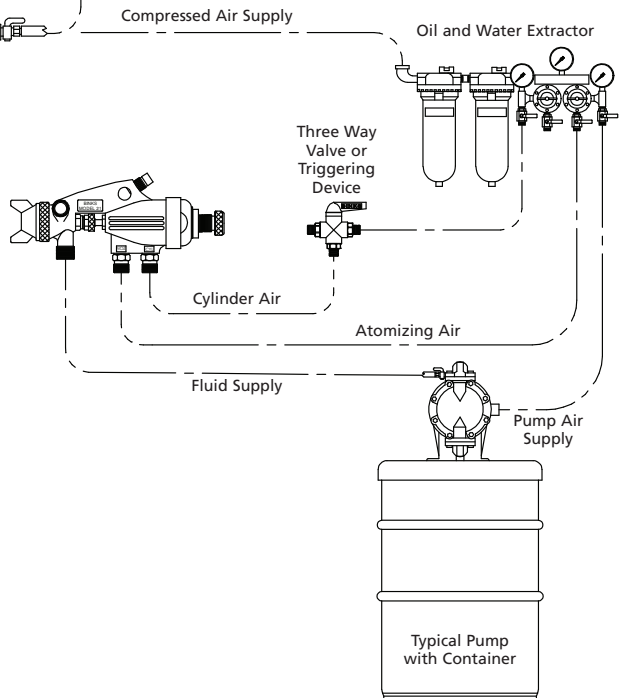

BINKS MODEL 21 & 21V SERIES AUTOMATIC SPRAY GUN

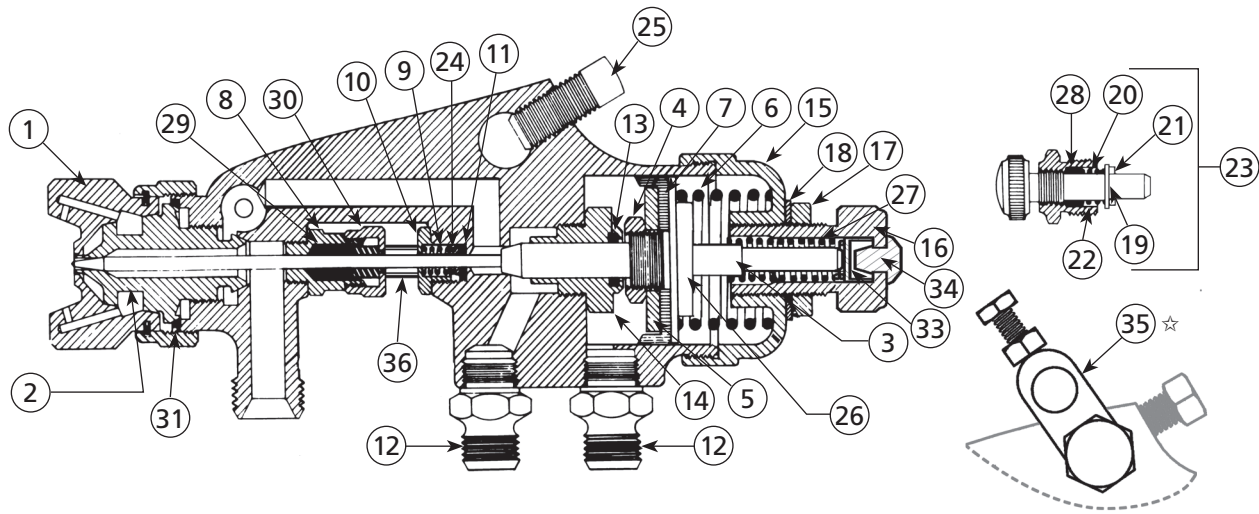

PARTS LIST

When ordering, please specify Part No.

ITEM NO.	PART NO.	DESCRIPTION	QTY.	ITEM NO.	PART NO.	DESCRIPTION	QTY.
1	○	NOZZLE Air	1	21	54-331•	PIN Side Port Control	1
2	○	NOZZLE Fluid.....	1	22	54-332•	FOLLOWER Side Port Control	1
3	■	FLUID NEEDLE.....	1	23	54-333	SIDE PORT CONTROL Complete....	1
4	54-232	LOCKNUT Plunger.....	1	24	▲ 54-334-5 * 54-446	FOLLOWER Packing	1 (Kit of 5) (Single Piece)
5	54-233	WASHER Plunger	1	25	54-335	SCREW Set	1
6	54-236	SPRING Plunger	1	26	▲ 54-337 * 54-444	VALVE Air.....	1
7	54-261•	PLUNGER Leather.....	1	27	54-728-5	SPRING Needle Valve	1
8	▲ 54-302 * 54-440	GLAND Packing	1	28	54-738-5•	PACKING Side Port Control.....	1
9	54-304-5•	SPRING Packing Follower.....	1 (Kit of 5)	29	▲ 2-28-5• * 54-1339	PACKING Needle Valve	1 (Kit of 5) (Single Piece)
10	54-306	NUT Air Packing	1	30	▲ 54-765 * 54-1353	NUT Packing	1
11	54-307-5•	PACKING Air	1 (Kit of 5)	31	54-918-5•	GASKET Fluid Nozzle (Kit of 5)	1
12	54-308	CONNECTION Air.....	2	32	OMX-88	BRUSH Cleaning (Not Shown)	1
13	54-310-5•	PACKING Air Valve	1 (Kit of 5)	33	54-6001	SPACER SPRING	1
14	54-312	GUIDE Air Valve.....	1	34	54-5522	VALVE UMBRELLA	1
15	54-321	BONNET	1	35	☆ 54-6004	(OPTIONAL) MOUNTING BRACKET ASSEMBLY	1
16	● 54-6003	SCREW Fluid Control	1	36	54-4270	NEEDLE COVER.....	1
17	54-323	LOCKNUT FLUID CONTROL.....	1				
18	54-324	WASHER Fluid Control Locknut	1				
19	54-329•	WASHER Side Port Control	1				
20	54-330•	SPRING Side Port Control.....	1				

○ When ordering, please specify number stamped on nozzle.

■ When ordering, please specify gun model and number stamped on needle.

• Parts also available in Repair Kit 6-191.

Gun wrench, 5-476 is recommended for removing fluid nozzle. Please order separately.

● Includes Item 34.

▲ 21 spray gun only.

* 21V spray gun only.

☆ Allows for easy gun change while maintaining gun alignment.

BINKS MODEL 21 & 21V SERIES AUTOMATIC SPRAY GUN

AIR CAP ORDERING GUIDE

AIR CAP MARKING	ORDER PART NUMBER	AIR CAP MARKING	ORDER PART NUMBER
200	46-2200	66PH	46-6016
252	46-2252	66SD	46-6020
262	46-2262	66SD-3	46-6092
21MD-1	46-21MD-1	66SK	46-6082
21MD-2	46-21MD-2	67PB	46-6026
21MD-3	46-21MD-3	68PB	46-6032
63PB	46-6002	709SS	46-2020

FLUID NOZZLE AND NEEDLE ORDERING GUIDE

FLUID NOZZLE MARKING	ORDER PART NUMBER	NEEDLE MARKING	ORDER NEEDLE NUMBER	ORIFICE SIZE INCHES (MM)	MATERIAL
59ASS	45-5911	259	47-25900	.171 (4.3)	Stainless Steel
59BSS	45-5912	259	47-25900	.218 (5.5)	Stainless Steel
59CSS	45-5913	259	47-25900	.281 (7.7)	Stainless Steel
63BSS	45-6321	263A	47-26310	.046 (1.2)	Stainless Steel
66SS	45-6601	265	47-26500	.070 (1.8)	Stainless Steel
68SS	45-6801	268	47-26800	.110 (2.8)	Stainless Steel
63CVT	45-6332	263CVT	47-26332	.052 (1.3)	Tungsten Carbide
67VT	45-6702	267VT	47-26702	.086 (2.2)	Tungsten Carbide
68VT	45-6802	268VT	47-26802	.110 (2.8)	Tungsten Carbide

INTERNAL MIX HEAVY MATERIAL NOZZLES (OPTIONAL)

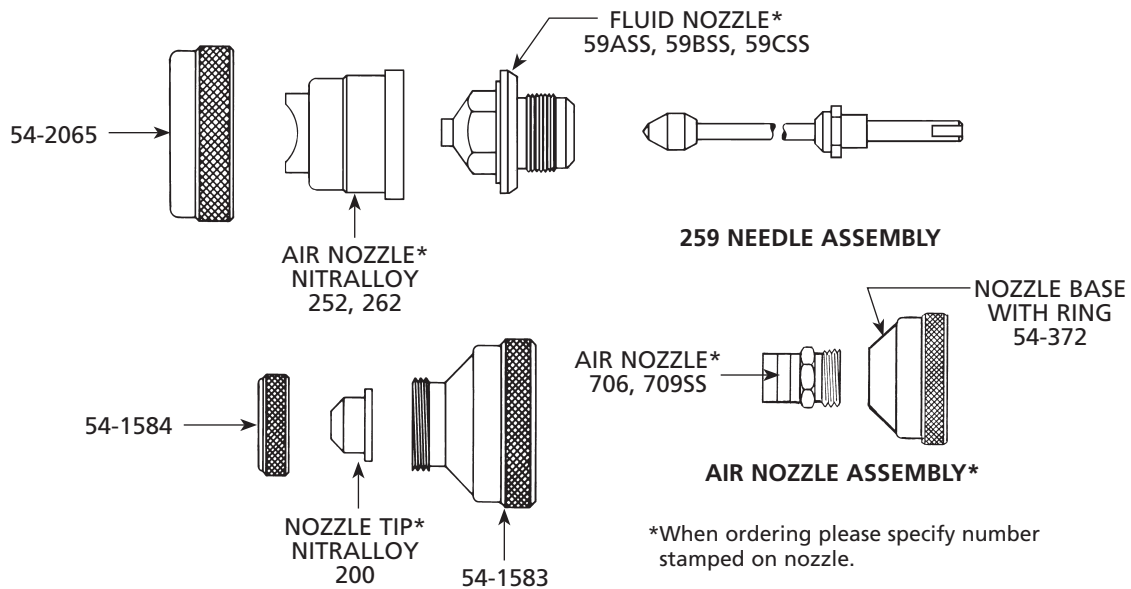

MODEL 21 NOZZLE AND NEEDLE SELECTION CHARTS

TYPE OF FLUID TO BE SPRAYED	FLUID X AIR NOZZLES	FLUID NEEDLE	GUN PART NUMBER	CFM @ 30 PSI	CFM @ 50 PSI	CFM @ 70 PSI	MAX PATTERN @ 8"
THIN, 5-25 CENTIPOISE wash primers, dyes, stains, solvents, water, inks, sealers, laquers, lubricants, zinc chromates, acrylics	63BSS X 63PB	263A	6220-2800-7	9.0	14.3	20.0	14
	66SS X 66SD	265	6220-4307-9	7.9	12.1	15.5	10.5
	63BSS X 21MD-1	263A	6220-2821-1	8.5	12.2	15.9	14
	63CVT X 66PH	263CVT	6235-3206-3	8.0	11.8	15.2	11
	66SS X 66SK	265	*	11.0	15.2	19.5	13
	63BSS X 200	263A	*	3.1	5.2	6.4	12
MEDIUM, 25-70 CENTIPOISE synthetic enamels, varnishes, shellacs, fillers, primers, epoxies, urethanes, lubricants, wax emulsions, enamels	63BSS X 63PB	263A	6220-2800-7	9.0	14.3	20.0	14
	66SS X 66SD	265	6220-4307-9	7.9	12.1	15.5	10.5
	63BSS X 21MD-1	263A	6220-2821-1	8.5	12.3	15.9	14
	63BSS X 21MD-3	263A	6220-2821-3	8.4	12.2	15.7	15
	67VT X 21MD-2	267VT	6235-4921-2	9.6	14.0	18.1	17
	63CVT X 66PH	263CVT	6235-3206-3	8.0	11.8	15.2	11
	67VT X 67PB	267VT	6235-4909-5	9.5	14.1	19.1	12
66SS X 66SK	265	*	11.0	15.2	19.5	13	
HEAVY, 70-115 CENTIPOISE	63BSS X 21MD-1	263A	6220-2821-1	8.5	12.3	15.9	14
	63BSS X 21MD-3	263A	6220-2821-3	8.4	12.2	15.7	15
	68SS X 709SS	268	6220-5123-7	4.3	6.9	8.9	6
	67VT X 21MD-2	267VT	6235-4921-2	9.6	14.0	18.1	17
	67VT X 67PB	267VT	6235-4909-5	9.5	14.1	19.1	12
	68SS X 68PB	268	*	9.5	14.1	19.1	12
VERY HEAVY, >115 CENTIPOISE texture coating, road marking paint	59BSS X 252	259	6220-8118-5	7.8	11.5	15.2	6
	59CSS X 262	259	6220-8219-1	7.3	11.0	14.7	6
	68SS X 68PB	268	*	9.5	14.1	19.1	12
ADHESIVES waterbase vinyl glues, solvent base, neoprenes, contact cement	66SS X 66SD-3	265	6220-4308-2	7.9	12.1	16.2	10
	63BSS X 66SD-3	263	*	7.9	12.1	16.2	4
MOLD RELEASE	63BSS X 63PB	263A	6220-2800-7	9.0	14.3	20.0	14
CERAMICS similar abrasive materials, glazes, engobes, porcelain enamel	67VT x 21MD-2	267VT	6235-4921-2	9.6	14.0	18.1	17
	67VT X 67PB	267VT	6235-4909-5	9.5	14.1	19.1	12
	68VT X 68PB	268VT	*	9.5	14.1	19.1	12
CONCRETE CURING COMPOUNDS	66SS X 200	265	*	3.1	5.2	6.4	15
MULTICOLOR PAINTS	66SS X 200	265	*	3.1	5.2	6.4	15
NON-STICK COATINGS	63BSS X63PB	263A	6220-2800-7	9.0	14.3	20.0	14
	66SS X 66SD	265	6220-4307-9	7.9	12.1	15.5	10.5
	63BSS X 21MD-1	263A	6220-2821-1	8.5	12.3	15.9	14
	63CVT X 66PH	263CVT	6235-3206-3	8.0	11.8	15.2	11
HAMMERS	66SS X 66SD	265	6220-4307-9	7.9	12.1	15.5	10.5
	66SS X 63PB	265	*	9.0	14.3	-	9.0
WRINKLE ENAMELS	66SS X 63PB	265	*	9.0	14.3	20.0	10.0
ZINC RICH COATINGS	67VT x 21MD-2	267VT	6235-4921-2	9.6	14.0	18.1	17
	67VT X 67PB	267VT	6235-4909-5	9.5	14.1	19.1	12

Set ups for vitreous/abrasive materials (Tungsten Carbide needles and fluid nozzles.)

*Set ups available as spares only.

200, 709SS, 252, & 262 are internal mix air caps.

BINKS MODEL 21M AUTOMATIC SPRAY GUN (6219-8219-1)

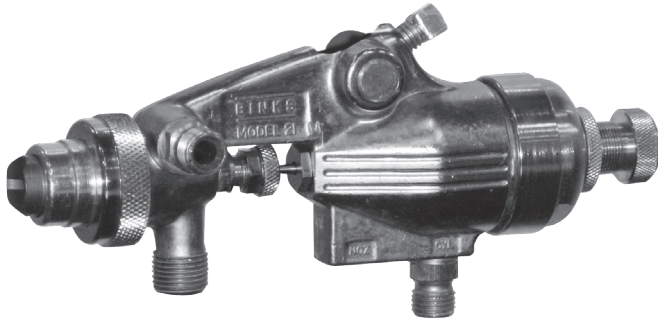

The Binks Model 21M is designed to deal with rough environments both inside and outside the spray gun. The Binks 21M spray gun will stand up to any line stripping process. The internal mix air cap keeps the spray pattern precise while the quick actuating air valve ensures material is only sprayed where and when you want it. The standard model includes a 0.281" orifice for heavy viscosity materials and an air cap that sprays up to a 7" pattern.

The Model 21M has the capability to quick flush the air and fluid nozzles, making it perfect for line stripping trucks. The diagram below shows the setup required for a quick flush.

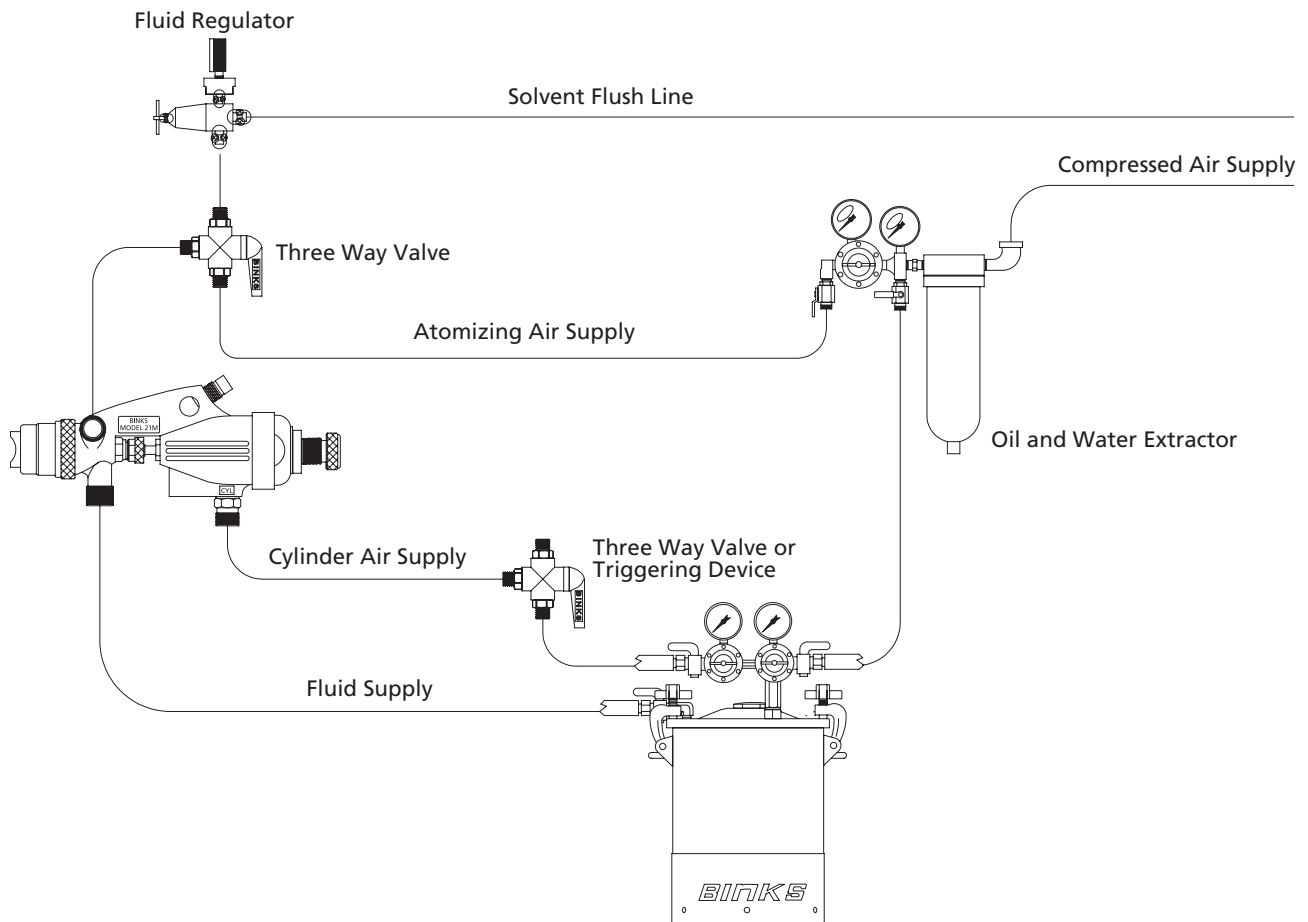

BINKS MODEL 21M (BRASS BODY) AUTOMATIC ROADMARKING SPRAY GUN

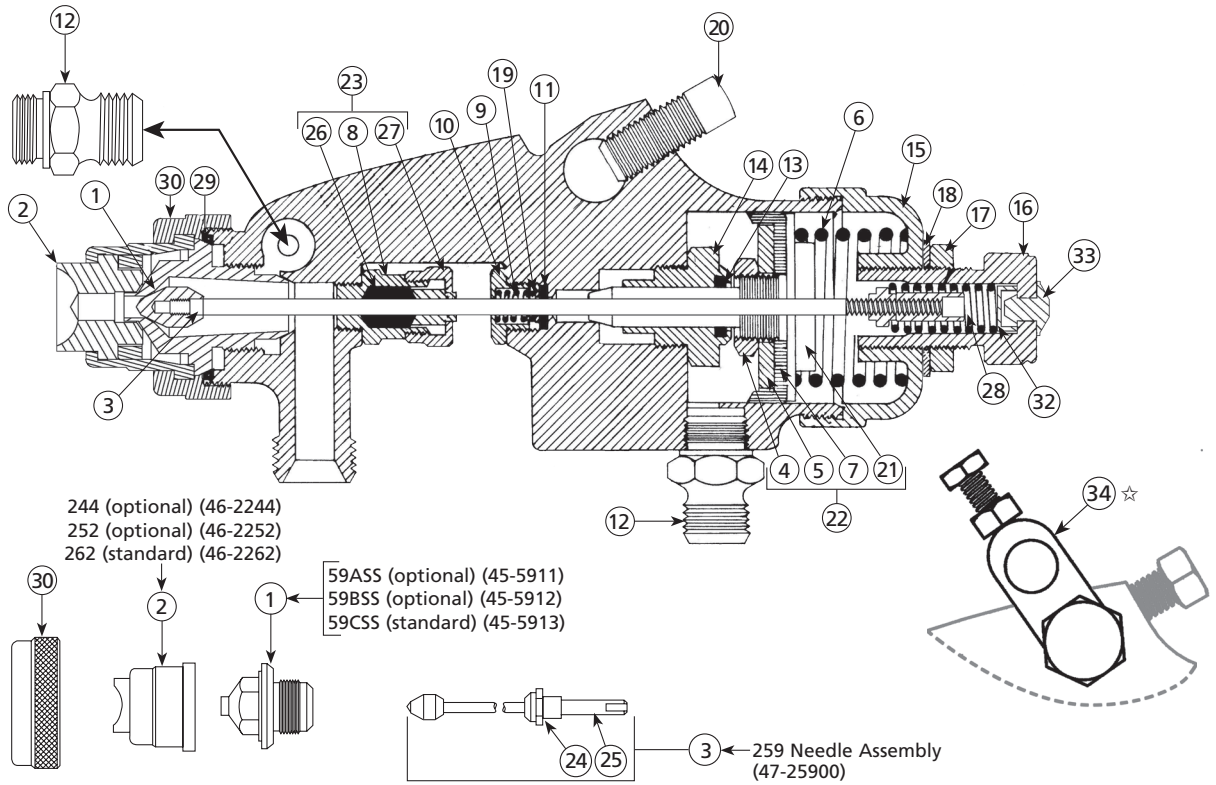

PARTS LIST

When ordering, please specify Part No.

ITEM NO.	PART NO.	DESCRIPTION	QTY.	ITEM NO.	PART NO.	DESCRIPTION	QTY.
1	45-5913	FLUID NOZZLE 59CSS (Standard)	1	19	54-334-5	PACKING FOLLOWER.....(Kit of 5)	1
2	46-2262	AIR NOZZLE 262 (Standard)	1	20	54-335	SET SCREW	1
3	47-25900	NEEDLE VALVE ASSEMBLY 259 ...	1	21	54-337▲	VALVE	1
4	54-232▲	NUT.....	1	22	54-495	PLUNGER ASSEMBLY	1
5	54-233▲	WASHER	1	23	54-496	PACKING BOX ASSEMBLY	1
6	54-236	PISTON SPRING	1	24	54-542	LOCKNUT (Part of Item No. 3).....	1
7	54-261▲	PLUNGER	1	25	54-763	LOCKNUT (Part of Item No. 3).....	1
8	54-302●	GLAND.....	1	26	2-28-5●	PACKING.....(Kit of 5)	1
9	54-304-5	SPRING.....(Kit of 5)	1	27	54-765●	NUT.....	1
10	54-306	PACKING NUT	1	28	54-839	NEEDLE VALVE SPRING.....	1
11	54-307-5	PACKING.....(Kit of 5)	1	29	54-918-5	AIR NOZZLE GASKET(Kit of 5)	1
12	54-308	AIR CONNECTION	2	30	54-2065	RETAINER RING.....	1
13	54-310-5	PACKING.....(Kit of 5)	1	31	OMX-88	BRUSH (NOT SHOWN)	1
14	54-312	GUIDE	1	32	54-6001	SPACER SPRING.....	1
15	54-321	BONNET.....	1	33	54-5522	VALVE UMBRELLA.....	1
16	54-6003■	CONTROL SCREW.....	1	34	☆ 54-6004	(OPTIONAL) MOUNTING	
17	54-323	CONTROL SCREW LOCKNUT	1			BRACKET ASSEMBLY	1
18	54-324	WASHER	1	35	54-4270	(OPTIONAL) NEEDLE COVER	1

- ▲ Part of 54-495 plunger assembly.
- Part of 54-496 packing box assembly.
- Includes Item 33.
- ☆ Allows for easy gun change while maintaining gun alignment.

Gun Wrench 5-476 is recommended for removing fluid nozzle. Please order separately.

No repair kit available. Please order parts separately.

NOTES

NOTES

WARRANTY POLICY

This product is covered by Carlisle Fluid Technologies' materials and workmanship limited warranty. The use of any parts or accessories, from a source other than Carlisle Fluid Technologies, will void all warranties. Failure to reasonably follow any maintenance guidance provided may invalidate any warranty.

For specific warranty information please contact Carlisle Fluid Technologies.

For technical assistance or to locate an authorized distributor, contact one of our international sales and customer support locations.

Region	Industrial / Automotive	Automotive Refinishing
Americas	Tel: 1-800-992-4657 Fax: 1-888-246-5732	Tel: 1-800-445-3988 Fax: 1-800-445-6643
Europe, Africa, Middle East, India	Tel: +44 (0)1202 571 111 Fax: +44 (0)1202 573 488	
China	Tel: +8621-3373 0108 Fax: +8621-3373 0308	
Japan	Tel: +81 45 785 6421 Fax: +81 45 785 6517	
Australia	Tel: +61 (0) 2 8525 7555 Fax: +61 (0) 2 8525 7575	

For the latest information about our products, visit www.carlisleleft.com

Carlisle Fluid Technologies is a global leader in innovative finishing technologies. Carlisle Fluid Technologies reserves the right to modify equipment specifications without prior notice.

BGK™, Binks®, DeVilbiss®, Hosco®, MS®, and Ransburg® are all registered trademarks of Carlisle Fluid Technologies, Inc.

©2020 Carlisle Fluid Technologies, Inc.
All rights reserved.

