

BINKS® FILTER ASSEMBLIES
MODEL 207-12259-1 (60 MESH)
MODEL 207-12259-2 (100 MESH)

⚠ CAUTION

Maximum working pressure of this assembly is 1800 psi (124 bar).

⚠ CAUTION

Before performing any maintenance on this assembly:
Make sure to relieve all pressure from system.

ITEM	PART NO.	DESCRIPTION	QTY.	
			207-12259-1	207-12259-2
1	237-847	PULSATION CHAMBER	1	1
2	207-12282	ADAPTER WITH O-RING	1	1
2a	237-848	O-RING	REF	REF
3	72-999	DM NIPPLE	1	1
4	20-4283	SWIVEL ADAPTER	1	1
5	237-280	STREET TEE	1	1
6	20-2097	PIPE PLUG	1	1
7	20-2605-1	PIPE PLUG	2	2
8	207-11689	FILTER HEAD	1	1
9	237-696	O-RING	1	1
10	207-11691	FILTER SUPPORT	1	1
11	207-11693	SCREEN - 60 MESH	1	-
11	207-11694	SCREEN - 100 MESH	-	1
12	207-11697	SPRING	1	1
13	207-11688	FILTER BOWL	1	1
14	72-13030	HP BALL VALVE	1	1

NOTE

Pulsation chamber to be used in a vertical position as shown. Be sure to check the pulsation chamber regularly for material build up.

REPLACEMENT PARTS

This filter assembly is designed to use authorized parts only. When using this filter assembly with parts that do not comply with the minimum specifications and safety devices of Binks, the user assumes all risks and liabilities.

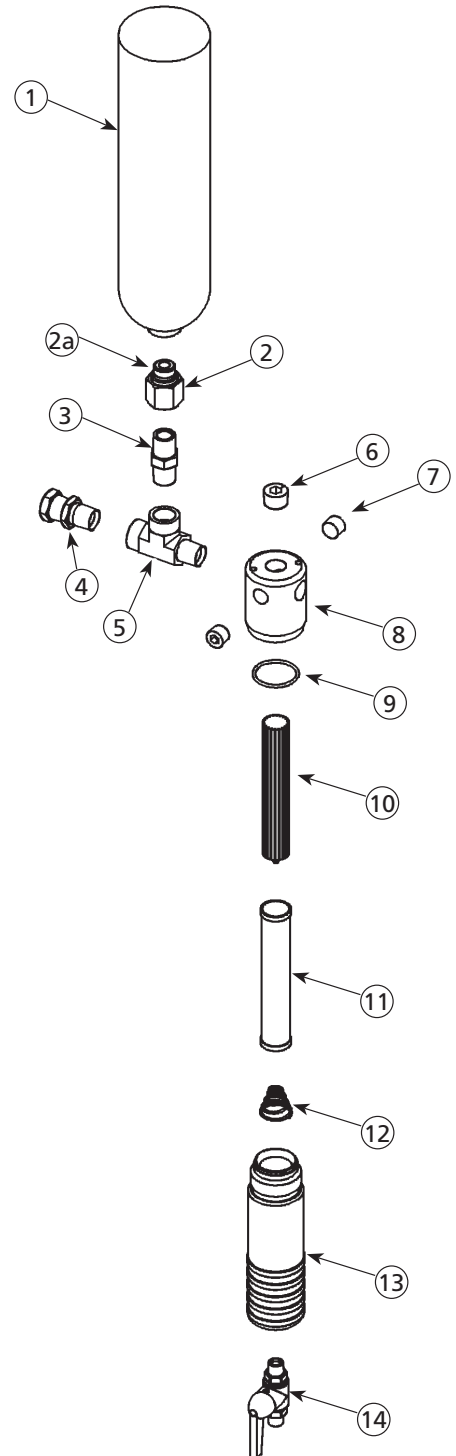

WARRANTY POLICY

This product is covered by Carlisle Fluid Technologies' materials and workmanship limited warranty. The use of any parts or accessories, from a source other than Carlisle Fluid Technologies, will void all warranties. Failure to reasonably follow any maintenance guidance provided may invalidate any warranty.

For specific warranty information please contact Carlisle Fluid Technologies.

Carlisle Fluid Technologies is a global leader in innovative finishing technologies. Carlisle Fluid Technologies reserves the right to modify equipment specifications without prior notice.

DeVilbiss®, Ransburg®, ms®, BGK®, and Binks®
are registered trademarks of Carlisle Fluid Technologies, Inc.

©2018 Carlisle Fluid Technologies, Inc.
All rights reserved.

For technical assistance or to locate an authorized distributor,
contact one of our international sales and customer support locations.

Region	Industrial / Automotive	Automotive Refinishing
Americas	Tel: 1-800-992-4657 Fax: 1-888-246-5732	Tel: 1-800-445-3988 Fax: 1-800-445-6643
Europe, Africa, Middle East, India	Tel: +44 (0)1202 571 111 Fax: +44 (0)1202 573 488	
China	Tel: +8621-3373 0108 Fax: +8621-3373 0308	
Japan	Tel: +81 45 785 6421 Fax: +81 45 785 6517	
Australia	Tel: +61 (0) 2 8525 7555 Fax: +61 (0) 2 8525 7575	

For the latest information about our products, visit www.carlisleleft.com