

VIPER®

Mix-Tech Spray Gun



WARNING!!! Read all instructions carefully before assembling components and operating sprayer. Incorrect procedure could result in damage to the unit, severe personal injury and/or property damage. When spraying flammable materials, sprayer must be placed at least 20 feet from target in a well-ventilated area. Vapours can be ignited by static discharge or electrical sparks and result in severe personal injury. Airless sprayers generate high fluid pressure. Improper use could result in an injection injury.

INDEX

1.	Description of symbols.....	3
2.	General Cautions	4
3.	Introduction.....	6
4.	Description of the equipment	6
4.1	Technical Data	6
4.2	Assembly details	7
5.	Set-up	8
5.1	Grounding	8
5.2	Assembling the spray nozzle	8
5.3	Spray Gun Filter	8
5.4	Air Hose Connection	9
5.5	Material Hose Connection	9
6.	Hints for Airless & Mix-Tech Sprayer	10
6.1	Painting and Tip Selection.....	10
6.2	Spray Painting Method	10
7.	How to select tip and proper filter	11
8.	Proper system setting	12
8.1	Spring Tension Adjustment	12
9.	Cleaning.....	13
10.	Maintenance	13
10.1	Nozzle changing	13
10.2	Gun Filter changing.....	14
10.3	Needle changing	14
11.	Troubleshooting.....	15
12.	Parts Breakdown.....	16

1. Description of symbols

The signs and symbols used in this manual have the following meaning:

NOTE

marks a section of text which is especially relevant to safety. Special attention should be paid to this section and its contents strictly observed.



WARNING

marks a situation which could be dangerous. If not observed, death or very serious injury could result. Warning concerning electrostatic charging when spraying in metal containers. Take care to ground the spray gun through contact with the container in order to prevent a major static discharge.



INJECTION HAZARD

marks a situation, where pressure is in the system. Do not point the gun at anyone or any part of the body



DANGER OF EXPLOSION

marks a situation, where there is danger of explosion. Observation of this information is absolutely essential.



USE BREATHING PROTECTION

For health reasons, it is very important to pay attention to this warning.



WEAR PROTECTIVE GLOVES

To prevent burns, wear protective gloves with lower arm protection. Observation of this information is essential.

2. General Cautions

- Always follow safety precautions and warnings printed on paint container.
- Only use accessories supplied by the manufacturer. User assumes all risk and liability when using spray guns, hoses or other parts not complying with minimum specification and safety devices
- Inspect hoses before each use. Never use a damaged hose. High pressure in hoses with wear, leaks or splits may cause the hose to rupture and cause serious personal injury. Never try to stop or deflect leaks with any part of your body.
- Use extreme caution when cleaning spray tip guard. DO NOT try to wipe off build up around the spray tip before following shut down procedure. Follow the Shutdown Procedure, then follow the spray tip manufacturer's instructions for removing and cleaning the spray tip.
- Never attempt to change spray tip or leave the unit unattended without first shutting off pump, releasing fluid pressure, and locking the trigger safety lock.
- Use extreme caution when changing spray tip. Follow the Shutdown Procedure, then follow the spray tip manufacturer's instructions for changing the spray tip.
- Do not pull on hoses to move equipment, DO NOT kink or bend the hose sharply.
- Keep children or anyone not familiar with airless spray systems away from equipment and work area.
- Conductive metal containers must be used when flushing flammable fluids through the system. Always flush at low pressure with spray tip removed. A metal part of the spray gun must be held firmly against the grounded metal pail when flushing or relieving pressure from the gun.
- It is forbidden the use of the spray gun for dispensing flammable or highly toxic like gasoline, herbicides, pesticides..
- This spray gun was designed and built in accordance with all safety aspects and CE regulations
- During spraying, due to the speed of flow paint, in particular situations may accumulate on the equipment electrostatic charges that in discharging phase may generate sparks or flame. Due to this particular condition, ensure the proper grounding through a fluid feed flexible and the pump properly grounded.



Injection Hazard



High Pressure Painting can cause serious injury if the spray penetrates the skin. Do not point the gun at anyone or any part of the body. The tip guard provides some protection against accidental injection injuries, but is mostly a warning device. Never put your hand, fingers or body over the spray tip. Gloves and clothing do not necessarily offer any protection either. Keep the gun trigger safety lever in locked position when not spraying. Always have the tip guard in place while spraying. In case of penetration seek medical aid immediately!

Note to physician: Injection into skin is a serious traumatic injury. It is important to treat the injury surgically as soon as possible. Do not delay treatment to research toxicity. Toxicity is a concern with some exotic coatings injected into the blood stream. Consultation with a plastic surgeon or reconstructive hand surgeon may be advisable. Be prepared to tell the doctor what fluid was injected.

High Pressure Hazard

This system is capable of producing 200 Bar (2900 PSI). To avoid rupture and injury, do not operate this pump with components rated less than 200 bar (2900 PSI) working pressure (including but not limited to spray guns, hose and hose connections).

Do not spray paints or other inflammable fluids indoors which have a flash point below 21 degree C, 70 degree F. Keep spray area well ventilated. Before spraying, turn off all pilot lights and open flames.



Warnings for operator



Wear a respirator which is approved for the product being sprayed. Operator must wear appropriate protective equipment when operating, servicing or when is in the operating site in order to prevent serious injury, including eye injury, inhalation of toxic fumes, burns and hearing loss. We recommend to wear Protective eyewear, Clothing and respirator as recommended by the fluid manufacturer, Protective Gloves, Hearing protection.



Explosion Hazard

Do not use halogenated hydrocarbon solvents in this system; it contains aluminum parts and may explode. Cleaning agents, coatings, paints, and adhesives may contain halogenated hydrocarbon solvents. Don't take chances, consult your material supplier to be sure. (ex: methylene chloride and 1,1,1 - Trichlorethane)

Caution: When a flammable liquid is sprayed there maybe danger of fire or explosion especially in a closed area.

Caution: Arcing parts. Keep the pump at least 5 mt away from explosive vapors.

Warning: Static electricity can be developed by airless spraying. Ground unit and object to be sprayed. On electric units, unit power cord must be connected to a grounded outlet. Use only three wire extension cords. Static explosion can occur with ungrounded unit.

3. Introduction

We appreciate your decision to purchase a high quality professional paint spraying system and believe you will find it to be the best sprayer you ever owned. Your Mix-Tech Spray Gun is capable of spraying a wide variety of latex, oil-based and alkyd paints, as well as stains, preservatives, fire-proofing, water-proofing, and other many industrial coatings. The material you are spraying will have a direct effect on the amount of pressure required for the optimum pattern and coverage to be obtained. We recommend that before actually beginning your job, you carefully read this manual and practice with the sprayer until you feel comfortable using it.

4. Description of the equipment

VIPER® gun is a pneumatic operated spray gun used to atomize coatings at high pressure (up to 200 bar). VIPER® is operated by hand by operator and can handle coatings like varnishes, enamels, primers, polyurethane, solvent based coatings, water based paints. For other coatings we recommend to ask to the manufacturer. VIPER® spray gun is supplied in a cardboard box together with operating instructions and parts.



ATTENTION: Materials sprayed are varnishes and enamels synthetic, varnishes polyurethane, nitro, primers, dyed, water born paints.

For the use of the gun with special products must be obtained approval of manufacturer which is not liable for injuries resulting from the equipment by unauthorized personnel, unqualified or use it for purposes different as mentioned above.

It is prohibited from using a spray gun for dispensing flammable or highly toxic like gasoline, herbicides, pesticides.

4.1 Technical data:

Max. Working Fluid Pressure	120 bar (1740 psi)
Max. Working Air Pressure	8 bar (110 psi)
Max. Working Fluid Temperature	43 °C
Fluid Inlet	1/4"
Air Inlet	1/4"
Gun Weight (bare)	400 gr.
Gun Body	Forged Aluminum
Wetted Parts	Stainless Steel, Carbide, PTFE, Cu

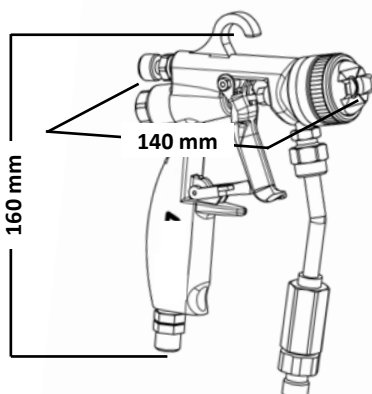

4.2 Assembly details

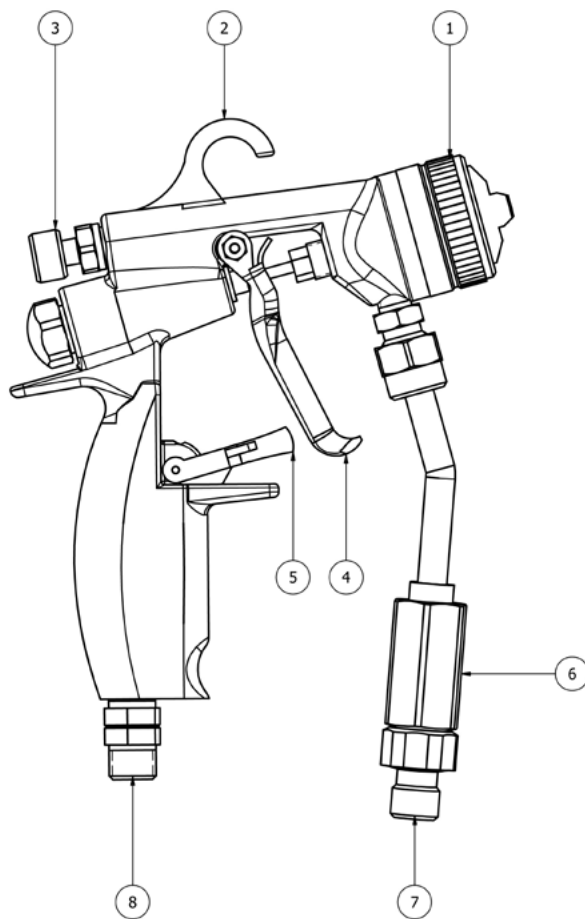

Pos. Description

- 1 AirCap complete
- 2 Hook
- 3 Fan regulator set
- 4 Trigger
- 5 Trigger lock
- 6 Filter Holder
- 7 Fluid connection
- 8 Air connection

5. Set-up

The spray gun is designed specifically for Mix-Tech spraying, i.e. the Spray gun can be used in Airless mode as well as in Mixed Air mode. The atomization is accomplished by the pressure (adjustable from 0 up to 200 Bar) through a pump. The air is used to improve the atomization quality and to increase or decrease the fan size by adjusting the proper fan regulator placed on the spray gun



WARNING: INJECTION HAZARD POSSIBLE. DO NOT SPRAY WITHOUT TIP IN PLACE. ALWAYS ENGAGE TRIGGER LOCK BEFORE REMOVING, REPLACING OR CLEANING TIP. NEVER TRY TO CLEAN THE TIP WITH YOUR FINGERS.



To prevent hazardous concentration of toxic and/or flammable vapors, spray only in a properly ventilated spray booth. Do not operate the spray gun unless ventilation fans are operating. Check and follow all of the Local and National Codes/Standards regarding exhaust velocity requirements. Check and follow all local safety and fire codes.

5.1. Grounding

Check your local code and pump manual for detailed grounding instructions. Use only electrically conductive fluid hoses. Ground the spray gun through connection to a properly grounded fluid supply hose and pump.

5.2. Assembling the spray nozzle

Warning: the proper nozzle size is essential for a good atomization on which depends the final result. The nozzle size is determined by the coatings used and the type of application. Ask to the coatings' manufacturer for the proper tip size.

1. Place the trigger lock in horizontal position in order to prevent accidental injection

WARNING: Before each nozzle change, assure to release the pressure in the spray gun and disconnect air supply.

2. Unscrew the nut
3. Remove the air cap
4. Remove the nozzle into the air cap
5. Place the nozzle into the air cap
6. Place the air cap complete with the nozzle into the spray gun
7. Screw the nut onto the spray gun

5.3 Spray Gun Filter

We suggest always to use a Gun Filter, unless the coatings used do not require it. The mesh size of the gun filter is determined by the nozzle size. See the table at page 10 for the suggested filter size.

5.4 Air hose connection

Attention: It is suggested to install an air filter on the gun air line to ensure a dry, clean air supply to the gun. Dirt and moisture can ruin the appearance of your finished worked piece. Install an air pressure regulator on the gun air line to control air pressure to the gun. Install an air shutoff valve on the gun air line and on the pump air line, to shut off air to the gun. Use a 3/16" (5mm) or even larger air hose to minimize excessive pressure drop in the hose.

1. Connect the air hose the air inlet placed on the gun.
2. Connect the other end of the air hose to the air pressure regulator placed on the pump

5.5 Material hose connection

Note: Before connecting the fluid line, blow it out with air and flush it with solvent. Use solvent which is compatible with the fluid to be sprayed. If better control of fluid pressure is needed, install a fluid regulator on the fluid line to better control fluid pressure to the gun.

3. Connect the material hose to material inlet placed on the gun.
4. Connect the other end of the material hose the material outlet placed on the pump.

Note: Only use hoses supplied or approved by the manufacturer

WARNING: Inspect hoses before each use. Never use a damaged hose. High pressure in hoses with wear, leaks or splits may cause the hose to rupture and cause serious personal injury. Never try to stop or deflect leaks with any part of your body.

6. Hints for Airless & Mix-Tech Sprayer

WARNING: DO NOT BEGIN SPRAYING BEFORE READING THIS SECTION AND ALL PREVIOUS SAFETY INFORMATION.

To disengage your trigger lock: Your spray gun is shipped from the factory with the trigger lock in the engaged position (horizontal). To disengage, turn the trigger lock down until it is in a vertical position. To engage the trigger lock, turn it back to a horizontal position.

6.1 Painting and Tip Selection

Correct adjustment of pressure and proper tip selection are crucial to the best spray pattern....

1. In any situation, the lowest pressure that gives an adequate spray pattern is the best pressure to use. It will give maximum pump and tip life and produce minimum overspray.
2. Typically, thicker materials require larger tips and higher pressures than thinner paints do. Some very thick paints may require slight thinning (5-10%) depending upon pump and tip size and application. Generally, thinning is performed when a good spray pattern cannot be obtained with an appropriate tip size at maximum pressure.

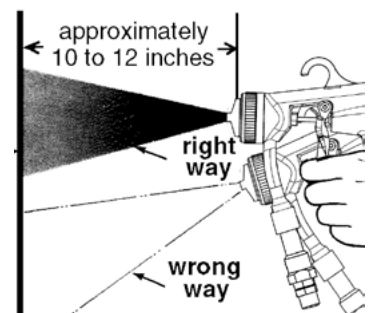

6.2 Spray Painting Method

1. Keep the gun perpendicular to the surface. Always hold the gun perpendicular to the surface with the tip approximately 12" from the surface. If held at an angle (up and down or side to side) paint will build up unevenly and leave the work splotchy.
2. Move with a smooth arm stroke. Move the gun at a steady even pace while keeping the gun perpendicular to the surface. Do not move the gun by flexing your wrist. Fanning the gun will cause excessive overspray and uneven coverage

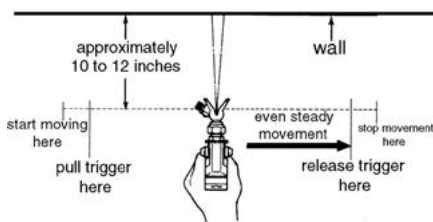

Proper way to trigger spray gun

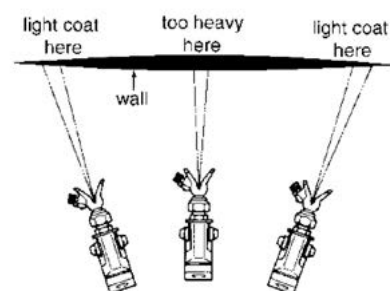

Result of flexing wrist while spraying

3. Start moving the gun before triggering. To get smooth overlap and prevent initial paint buildup, start our stroke movement before pulling the trigger. At the end of the stroke release the trigger before stopping. **NOTE:** To assure uniform paint coverage, overlap each stroke by 40% - 50%.
4. Intermittent use. If you are spraying and decide to stop for several minutes, lock the spray gun trigger and submerge the tip in a container of the appropriate solvent. This will prevent paint from hardening in the tiny spray opening and clogging the tip. Be sure to release the pressure by opening dump valve and turn off pump.

7. How to select tip and proper filter

Tip and filter table with specifications concerning capacity at different pressures (lt. minute) with water.
 Notice: For each tip size please choose between the following fan corners:

NOZZLE		CAPACITY MEASURED IN LT/MIN. AT FOLLOWING PRESSURES:				SUGGESTED FILTER	
Inches (mm)	Spray corner	35 Bar	70 Bar	105 Bar	140 Bar		
0,007 (0,18)	20 °	0,10	0,14	0,17	0,19	200 Mesh	
0,007 (0,18)	40 °	0,10	0,14	0,17	0,19		
0,007 (0,18)	60 °	0,10	0,14	0,17	0,19		
0,009 (0,23)	20 °	0,14	0,20	0,25	0,29		
0,009 (0,23)	40 °	0,14	0,20	0,25	0,29		
0,009 (0,23)	60 °	0,14	0,20	0,25	0,29		
0,011 (0,28)	20 °	0,22	0,3	0,38	0,45		150 Mesh
0,011 (0,28)	40 °	0,22	0,3	0,38	0,45		
0,011 (0,28)	60 °	0,22	0,3	0,38	0,45		
0,013 (0,33)	20 °	0,34	0,45	0,56	0,64		
0,013 (0,33)	40 °	0,34	0,45	0,56	0,64		
0,013 (0,33)	60 °	0,34	0,45	0,56	0,64		
0,015 (0,38)	20 °	0,45	0,60	0,75	0,85		
0,015 (0,38)	40 °	0,45	0,60	0,75	0,85		
0,015 (0,38)	60 °	0,45	0,60	0,75	0,85		
0,018 (0,44)	20 °	0,65	0,88	1,10	1,26	100 Mesh	
0,018 (0,44)	40 °	0,65	0,88	1,10	1,26		
0,018 (0,44)	60 °	0,65	0,88	1,10	1,26		
0,021 (0,53)	20 °	0,90	1,25	1,55	1,75	50 Mesh	
0,021 (0,53)	40 °	0,90	1,25	1,55	1,75		
0,021 (0,53)	60 °	0,90	1,25	1,55	1,75		
0,023 (0,58)	20 °	1,05	1,52	1,85	2,15		
0,023 (0,58)	40 °	1,05	1,52	1,85	2,15		
0,023 (0,58)	60 °	1,05	1,52	1,85	2,15		
0,026 (0,66)	20 °	1,30	1,98	2,30	2,73		
0,026 (0,66)	40 °	1,30	1,98	2,30	2,73		
0,026 (0,66)	60 °	1,30	1,98	2,30	2,73		
0,031 (0,79)	20 °	2,00	2,80	3,45	4,15		
0,031 (0,79)	40 °	2,00	2,80	3,45	4,15		
0,031 (0,79)	60 °	2,00	2,80	3,45	4,15		
0,036 (0,91)	20 °	2,65	3,50	3,82	4,55		not recommended
0,036 (0,91)	40 °	2,65	3,50	3,82	4,55		
0,036 (0,91)	60 °	2,65	3,50	3,82	4,55		

8. Proper system setting

In order to obtain a proper atomization and a good finishing, below are the suggested set-up to apply on the equipment's settings and on the Mix-Tech Spray Gun's settings.

1. Set the fluid pressure on the pump according to the product's viscosity (from 0 up to 200 bar)
2. Set the gun air pressure on the pump according the fluid to spray
3. Adjust the Fan Regulator Set on the Mix-Tech gun if it is necessary to increase or decrease the fan width

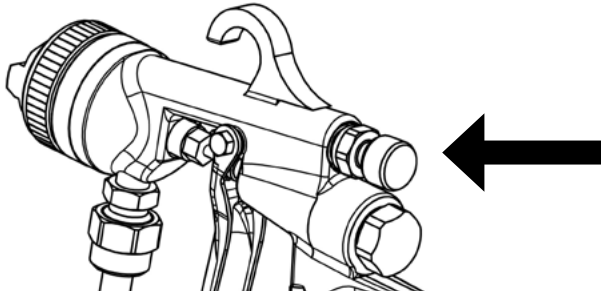

8.1 Spring Tension Adjustment - Only for "A" Versions

Your Mix-Tech Spray Gun "A" Version is supplied with spring tension closed in order to meet standards for safety. For a proper spraying it is necessary to set the Spring Tension Adjuster according to the pump pressure (Max. 200 Bar)

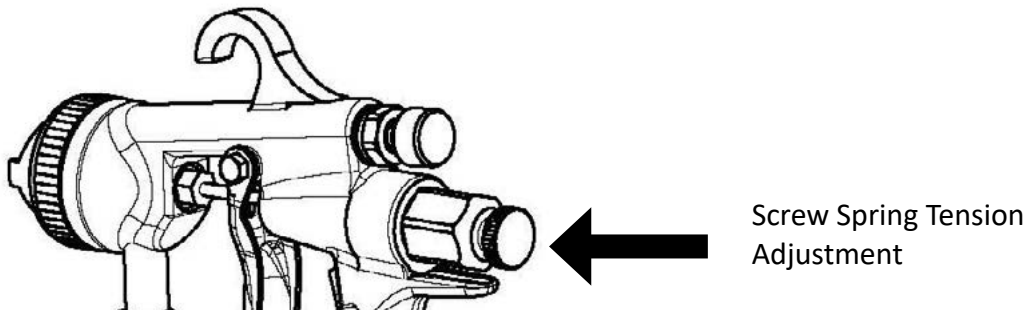

By reducing the pressure at the pump allows to open the adjustment screw of trigger tension accordingly.

Lower working pressure at the pump = Turn CCW the screw accordingly

9. Cleaning

Your Mix-Tech Spray Gun must be cleaned properly or it will not operate properly. Clogged nozzle and filters are the most common causes of problems. If followed, these guidelines will insure trouble free performance from your sprayer.



WARNING: Flush vigorously immediately after use or longer work interruptions with solvent corresponding to the spraying material. Ask to the material's manufacturer for the proper cleaning fluid.

10. Maintenance

Here below are indicated the procedures to replace the common wear parts.



Warning: Before to intervene on the spray gun, assure to release all the remaining pressure and disconnect air supply.

Warning: Assure to lock the trigger before to intervene on the spray gun.

10.1 Nozzle changing

The nozzle is one of the most important element in producing a quality spray job. It requires periodic replacement to maintain performance and to prevent overworking of the gun components.

1. Disassemble the AirCap (pos. 1)
2. Remove from the AirCap the Nozzle (pos. 2)
3. Clean well all parts and holes with a brush, using the proper cleaner.
4. Replace the worn parts if necessary

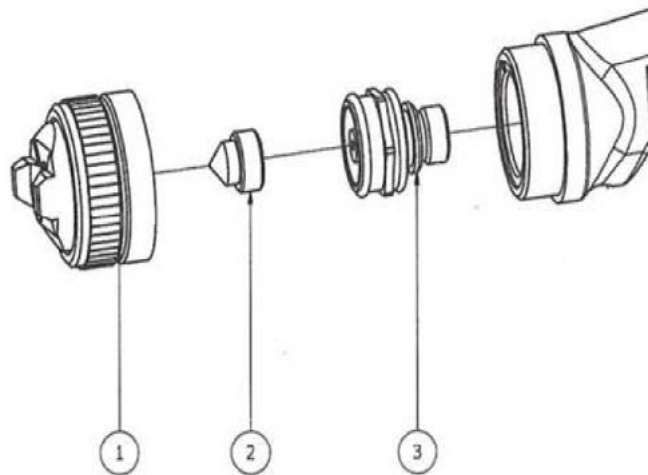

10.2 Gun Filter changing

NOTE: It is important to clean the gun filter regularly in order to minimize tip clogging problems. Use the proper solvent according to the paint used.

1. Unscrew the Filter holder (pos. 6) with the proper wrench
2. Remove the gun filter, clean it or replace if necessary.

10.3 Needle changing

The components which enter in contact with the material sprayed can require in time to be replaced.

1. Disassemble the AirCap (pos. 1)
2. Remove the Nozzle (pos. 2)
3. Remove the Diffuser (pos. 3) with a wrench nr. 22
4. Remove the Rear Cap (pos. 22) with a wrench nr. 17
5. Remove the springs (pos. 21 and 19)
6. By using a pincers remove the needle (pos. 20), clean it or replace if necessary

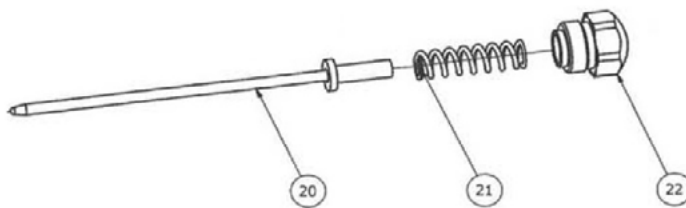

10.4 Packing Adjustment

In case of fluid leakage from the seal screw nut it is enough to screw the Seal screw adjusting nut with a wrench nr. 7. if leakage persists we suggest to replace the seal and the pressure washer.



Warning: Before to intervene on the spray gun, assure to release all the remaining pressure and disconnect air supply.

Warning: Assure to lock the trigger before to intervene on the spray gun.

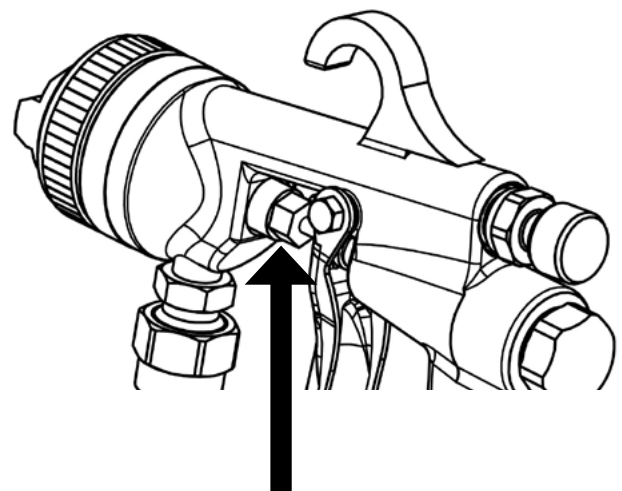

11. Troubleshooting

Our products are carefully tested and their quality is excellent, thus the gun-life and its good performance principally depends on careful cleaning and maintenance.

PROBLEMS	CAUSES	REMEDIES
Low flush of materials	<ul style="list-style-type: none"> a. Gun butt filter is clogged b. Viscosity is too high c. The nozzle is too big or clogged d. Working pressure is too low 	<ul style="list-style-type: none"> a. Clean it or replace it if necessary b. Thin the product c. Replace it with a smaller one d. Increase the pressure
The spraying is not even	<ul style="list-style-type: none"> a. Nozzle is clogged b. Gun butt filter is clogged c. The nozzle is too big or clogged b. Viscosity is too high e. Atomisation air is too low f. Material passages are clogged g. Compressed air is too high 	<ul style="list-style-type: none"> a. Clean it or replace it if necessary b. Clean it or replace it if necessary c. Replace it with a smaller one d. Thin the product e. Alncrease the pressure f. Clean the material passages with a plastic brush (not in metal) g. Reduce the pressure from the pump
Gun leaks	<ul style="list-style-type: none"> a. Seal screw is worn or too loose b. Diffuser is worn c. Needle is worn 	<ul style="list-style-type: none"> a. Screw the seal screw adjusting nut with a wrench nr. 7 b. Clean it or replace if necessary c. Clean it or replace if necessary
Gun leaks air	<ul style="list-style-type: none"> a. Air valve set (pos. 18) is worn 	<ul style="list-style-type: none"> a. Replace it
Gun do not spray	<ul style="list-style-type: none"> a. Filter clogged b. Material hose clogged 	<ul style="list-style-type: none"> a. Replace it b. Replace it
Spraying not uniform	<ul style="list-style-type: none"> a. Nozzle partially clogged b. Nozzle worn 	<ul style="list-style-type: none"> a. Clean with proper tools b. Replace it

VIPER® Mix-Tech Spray Gun

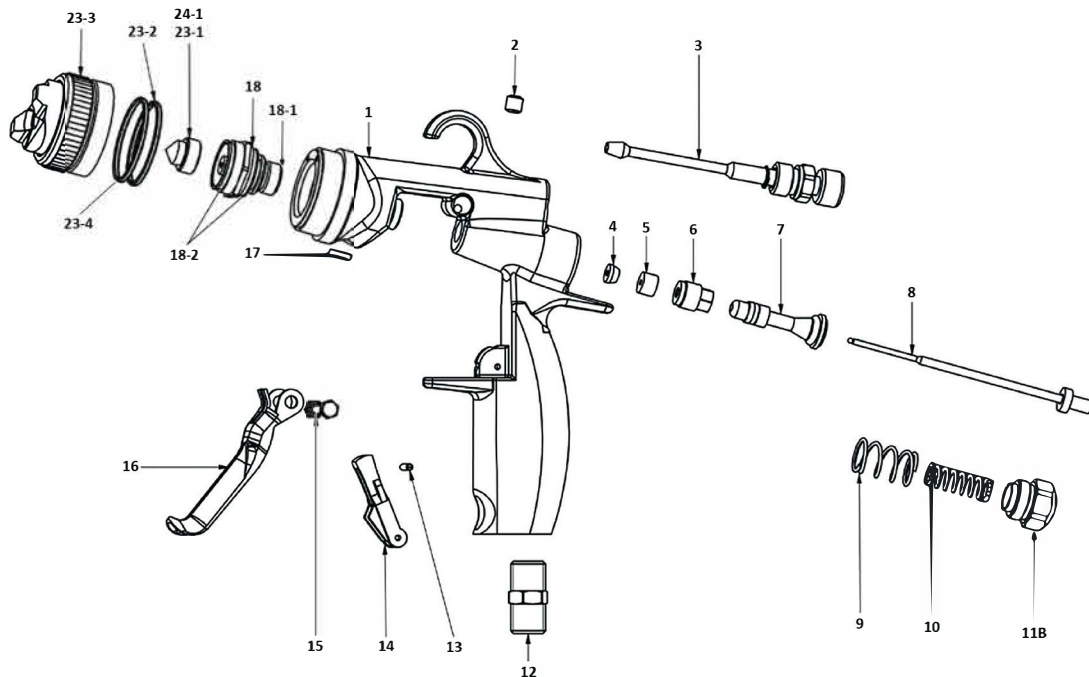

Ref. No.	Part No.	Description
2	TFS41-V002	Wedge
3	TFS41-V003	Fan Regulation Set
4	TFS41-V004	Pressure Wedge
5	TFS41-V005	Fluid Needle Gasket
6	TFS41-V006	Fluid Needle Screw
7	TFS41-V007	Air Valve Complete
8*	TFS41-V008	Needle Set
9	TFS41-V009	Air Valve Spring
10	VPR-60BAR	Needle Spring 60 Bar
	TFS41-V010	Needle Spring 120 Bar
	TFS23-V0010	Needle Spring 200 Bar
11B	TFS41-V11B	Back Cap
12	TFS41-V012	Air Inlet ¼"
13	TFS41-V013	Pin
14	TFS41-V014	Safety Lock
15	TFS41-V015	Trigger Pin
16	TFS41-V016	Trigger
17	TFS41-V017	Sealing Gasket
18	TFS41-V018	Gun Head / Diffuser Set
18-1	389189739	Rear Gasket Seal
18-2	450120987	Diffuser O-Ring
23-1	4035XXXX12	Mix Nozzle Standard
23-2	450120990	Air Cap Gasket
23-3	398160060	Air Cap Type VX24 Comparable Non-OEM
23-4	389010225	Air Cap Flat Gasket
24-1	12105XX18	Pre-Atomized Nozzle (Ultra Tip)
	388589709	Tip Seal
	389160450	Complete Needle Kit 120 Bar

* Included in Complete Needle Kit 120 Bar



TOTAL
FINISHING™

Call: (844) 898-1082

Email: sales@totalfinishingsupplies.com

Website: TotalFinishingSupplies.com

Technical data subject to change

