

Pro-MAX™ Ultraviolet Sterilizer

Setup and Instructions



Lifeguard Aquatics introduces the Pro-MAX™ UV Sterilizer, featuring a patent-pending, flow-through design with less restrictive angled inlet and outlet ports requiring less plumbing. This unique design enables easy installation of new or replacement systems as it can be positioned in multiple ways to fit any tight space. Available with 3" housing in 25, 40, 55, 90 and 120 Watt models and 5" housing in 55, 90 and 120 Watt sizes. Each Pro-MAX™ features a High Output UV Bulb, Internal Protective Sleeve, and UL Listed Ballast which counts down the number of days until you need to replace the bulb. Maximum Operating Pressure 30 PSI.

3" Amalgam High Output UV 55W, 90W and 120W	5" Amalgam High Output UV 55W, 90W and 120W	3" Standard High Output UV 25W and 40W

Part No.	Description	Lamp Watts	Lamp Current	UV Output Micro Watts	UVC $\mu\text{W}/\text{cm}$	Lamp Life (Hours)	UV-C Output (Watts)	Max Flow Rate	Max Water Flow Algae & Bacteria	Max Aquarium Size	Max Pond Size
R450105	3" Standard High Output UV 25W	25	1.2A	0.05	50	9000	7.5	1000 GPH	550 GPH	130 Gallons	2400 Gallons
R450106	3" Standard High Output UV 40W	40	1.2A	0.125	125	9000	12	2500 GPH	1200 GPH	250 Gallons	4700 Gallons
R450107	3" Amalgam High Output UV 55W	55	1.2A	0.15	150	9000	16.5	3600 GPH	2100 GPH	350 Gallons	6000 Gallons
R450108	3" Amalgam High Output UV 90W	90	1.2A	0.27	270	9000	28	4600 GPH	2800 GPH	650 Gallons	11000 Gallons
R450109	3" Amalgam High Output UV 120W	120	1.2A	0.32	320	9000	37	6000 GPH	4000 GPH	900 Gallons	14500 Gallons
R450110	5" Amalgam High Output UV 55W	55	1.2A	0.15	150	9000	16.5	4000 GPH	2100 GPH	350 Gallons	6000 Gallons
R450111	5" Amalgam High Output UV 90W	90	1.2A	0.27	270	9000	28	5500 GPH	2800 GPH	650 Gallons	11000 Gallons
R450112	5" Amalgam High Output UV 120W	120	1.2A	0.32	320	9000	37	7000 GPH	4000 GPH	900 Gallons	14500 Gallons

When you receive your Pro Max UV Sterilizer open the box and familiarize yourself with the parts breakdown in line drawing at the end of the instruction booklet.

Setup Instruction:



The UV comes semi-assembled. You need to install the quartz sleeve (#14), the gaskets (#16 and #19), the bulb (#17) and connect the ballast.

Remove to 2" nuts (#1) holding the inlet/outlet elbows (#23), on the UV clear individual 2" nuts on the UV). Once the parts are removed you will see the O-rings (#3). Make sure they're installed properly as seen in the **Figure 1**.

Once a year these O-rings (#3, 8, 16, 19) need year servicing by applying aquatic friendly silicone lubricant to make sure they don't get brittle or crack.



Look at the UV clear cap (#15). It has a tapered hole on the inside of the threads. The other end of the sterilizer is the UV end cap (#2). It has a hold on that holds the Quartz sleeve (#14) and acts as the quartz sleeve guide. When you are installing the quartz sleeve it will sit inside the UV end cap. It makes sure that the quartz sleeve is perfectly aligned and in the center of the sterilizer.



When you look inside the 2" openings you will notice there is a white protective sleeve (#7, 13) on the inside of the UV. This is the replaceable sleeve that you need to service once a year to make sure that the UV light damaged does not extend to the black UV housing. We will cover this again in the service section at the end.



Now put the clear fittings back and hand tighten the nuts and make sure they close and seal properly.



When you open the UV box you will notice two additional boxes. The smaller box contains the UV ballast and the larger box contains the UV bulb (#17) and quartz sleeve (#14). Please note that the 3" Size UV in 25 watt and 40 watt have a standard UV bulb and a standard UV ballast. The 3" and 5" Size UV's in 55 watt, 90 watt and 120 watt have an amalgam UV bulb and a amalgam UV ballast with a day counter.

Remove the ballast from the box you will see the parts in [Figure 2](#).

The small bag in the UV box containing one O-ring (#19) and a larger tapered/flat Gasket (#16).

Familiarize yourself with all the parts that come with the Pro Max UV to connect the Quartz Sleeve, Quartz Bulb and Ballast to achieve proper seal.

NOTE: The ballast shown in these photos is an Amalgam UV ballast used in 55, 90, 120 Watt UV.



Figure 2

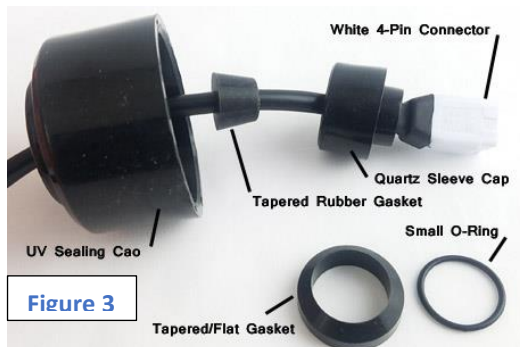

Familiarize yourself to the part and note where the White 4-pin connector of the UV ballast is located.

From right to left you will see the white 4-pin connector followed by the plastic quartz sleeve cap (#20) followed by the tapered rubber gasket 'seal' (#21) to seal the cable and finally the UV sealing cap (#22). [Figure 3](#)

Install the small O-ring (#19) inside the quartz sleeve cap as shown in the image below. Make

sure the O-ring fits properly in the round gap. You can use the quartz sleeve to gently push it in or just use your fingers to make sure it's flashed all the way. This is where the Quartz Sleeve will slide in to make a moisture resistant seal.



Open the do box for the quartz sleeve. You have to be very careful and gentle when working with the quartz sleeve and UV bulb as it can break or crack with force and can result in injury. Take Extreme Caution and don't use force when installing the quartz sleeve and UV bulb.

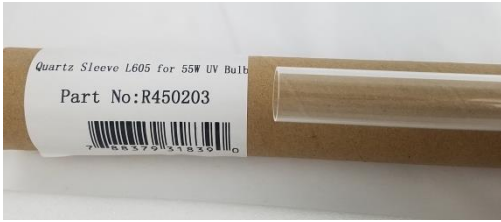

Install the tapered/flat quartz sleeve rubber gasket (#16) as shown below with the tapered end going on to the quartz sleeve first and the flat end close to the quartz sleeve opening.

In 2021 Lifeguard introduced the new add-on parts kit to your Pro Max will allow you to seal the quartz sleeve internally so when you plan to service the UV and change the UV bulb the water will not drain from the Pro Max. In addition it is a secondary seal to protect the UV bulb. Part Number: R450230

	<p>The add-on parts kit consists of a:</p> <ul style="list-style-type: none"> A - Dual Threaded view Port B - Quartz Sleeve Flat Locking Gasket C - Quartz Sleeve Locking Nut <p>NOTE: The Quartz Flat Sleeve Locking Gasket goes on to the part with the smaller groove.</p>	
	<p>NOTE: As precautions make sure to wipe off any fingerprints or oil residue from the quartz sleeve and the UV bulb if it comes in contact with your hand. Quartz sleeve and bulb need to be residue-free otherwise it can result in a burn mark which can reduce the effectiveness of the UV. Slide the Large Tapered Gasket on to the Quartz Sleeve Open end as shown below. NOTE: This end of the Quartz Sleeve slides in to the deeper end of the View Port</p>	



Before you install the bulb inside the quartz sleeve - note that the male end 4-pin connector of the bulb has to match the 4-pin connector of the ballast. They're not Square they more rectangular so you need to align them properly otherwise you can damage the bulb or the ballast end. Make sure the two 4-pin connector (bulb end and ballast end) are flushed all the way.



Gently slide the bulb inside the quartz sleeve. Followed by the thin wires (In order to properly place the wire of the UV bulb inside the quartz sleeve - you can ring the wire around your finger and gently slide it inside the quartz sleeve), followed by the two connected 4-pin connectors. [Figure 5](#)

Push the bulb into the quartz sleeve using the ballast 4-pin connector. Be careful and gentle – Applying force can damage the quartz sleeve. As shown in the image below press the quartz sleeve cap on to the quartz sleeve so it is flushed with the tapered/flat rubber gasket. Make sure the tapered/flat rubber gasket fits flat on top of the quartz sleeve cap and there is no

space. Press the tapered rubber gasket onto the quartz sleeve cap and press it in. This will make the seal on the cable and the sleeve so that moisture does not get in.

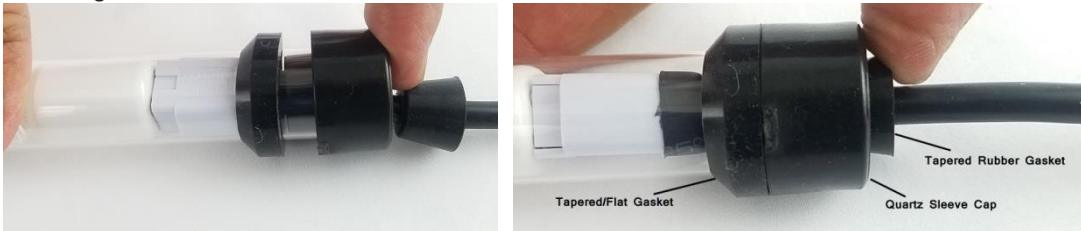

Gently slide in the quartz sleeve into the UV Housing as shown in the figure below and make sure it reaches the back and of the UV end cap and sits into the guide assembly as discussed earlier.

	<p>First time setup – It is easier if you stand the Pro Max UV on the Flat view port side and install the quartz sleeve. Let gravity hold it in place.</p> <p>Open the tube for the UV bulb (#17). Here just for reference and amalgam bulb has one or two mercury dots close to the middle of the bulb. This mercury dot is an indication of the amalgam bulb. The standard high-output UV bulb for 25 and 40 watt UV are not Amalgam so they don't have this dot. Figure 4</p>	
	<p>Hand-tighten the UV Cap Nut. Hold the UV Cap Nut and while keeping it straight 'GENTLY' twist the Quartz Sleeve. There should be no movement - otherwise hand-tighten a little more.</p> <p>Slide over Item B - Quartz Sleeve Flat Locking Gasket on to the Quartz Sleeve as shown below.</p>	
	<p>Slide over Item C - Quartz Sleeve Locking Nut on to the Quartz Sleeve as shown below.</p> <p>Hand-tighten the Quartz Sleeve Locking Nut on to Item A - Dual Threaded view Port Now you are ready to install the Quartz Bulb and Sleeve Assembly into the Pro Max UV Housing.</p>	



Connect the power cable into the ballast. Please note that for the amalgam style ballast have a day counter and the power cable is detachable from the ballast. While for the standard 25 watt and 40 watt UV ballast does not have a counter and the ballast has the cable permanently connected.

Connect the UV ballast power cable to a GFCI protected socket. Make sure to Loop the cable so moisture or water does not go near the power cables. Press the counter button, you will hear a beep and the day counter will begin with 365. The green LED light indicated that the UV bulb and UV ballast are working properly. In case something is wrong or the bulb goes out or there is moisture or water damage the red light will show.

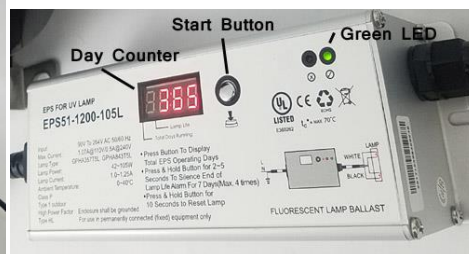

Your UV has to clear view ports on either end where you can see the blue UV light indication your Pro Max UV is working fine.

Service

UV requires annual servicing. You need to change the bulb once every 12 months. After 12 months of use the bulb light may be on but the UV output gets reduced beyond effectiveness. So it is recommended you change the bulb every 12 months even if it is working. Turning the UV on/off reduces the life of the UV bulb.

In addition you also need to service the O-rings and Gasket. You can use silicone lubricant to protect the gaskets. If you notice any gasket has cracks or is dry promptly change it to avoid any further damage.

But protective sleeve on the inside of the UV needs to be replaced once a year to make sure the UV does not damage the actual housing.



To service your UV unscrew the four stainless steel housing bolts or Housing Lock Nuts (#4, #6).

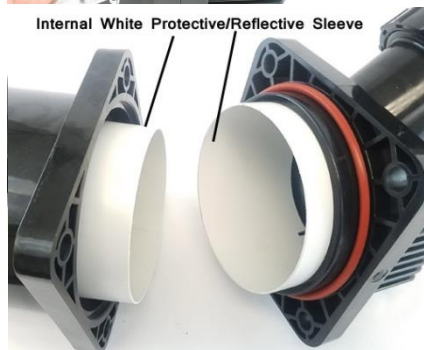

When you remove the inlet/outlet or end caps you will notice the large O-ring – the Housing O-ring (#8).

Once the sides are removed you will see the white protective / reflective sleeve (#7, #13). These sleeves have a reflective coating that increases the efficiency of the UV contact and output.

Every Pro Max UV has three sections of protective sleeves one large sleeve for the center housing pipe (#12) and two for the end caps (#5).

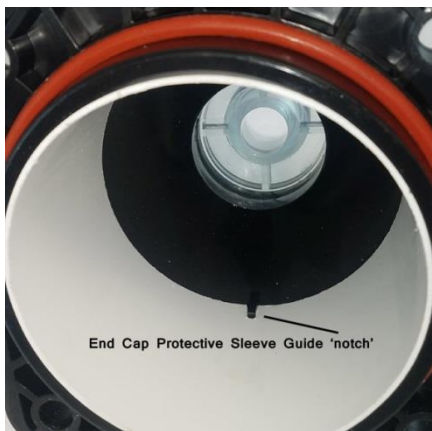

Note there is a notch on one end of the protective sleeve for the end caps. Aligning the notch with the guide makes you're your protective sleeve is installed properly and the inlet/outlet openings are not restricted.

Once you replace all the protective sleeves and have serviced all the O-rings you can close and seal the end caps by gently tightening the stainless steel nuts.

LIFEGARD
AQUATICS
Quality Pond & Aquaculture Products

www.lifegardaquatics.com
info@lifegardaquatics.com

CAUTION:

- Do not look directly at UV light. Exposure to UV light can cause eye, skin, and tissue damage.
- Use GFCI grounded plug to prevent electric shock.
- Do not cut any cable or wires. Cutting cable will Void Warranty.
- Only use Lifegard Aquatics specified UV Bulb, Quartz Sleeve, and Ballast with this unit. Third party replacement parts may cause leaking, electric shock, or other damage and will Void Warranty.
- Not for submersible use.
- 30 PSI Maximum Operating Pressure.
- Do not operate without water. Make sure UV housing is full of water before turning on UV bulb.
- All "O" Rings, Protective Sleeves, and Gaskets should be replaced every 12 months to avoid possible leaks and damage.
- Replace UV Bulb every 12 months or 9000 hours.
- Safe for Freshwater or Saltwater use.

CAUTION
High Intensity
ultraviolet light.
Avoid eye & skin
exposure.
www.lifegardaquatics.com



SCAN ME

Scan to Video Instructions link
<https://youtu.be/XbHxeGQmJWs>

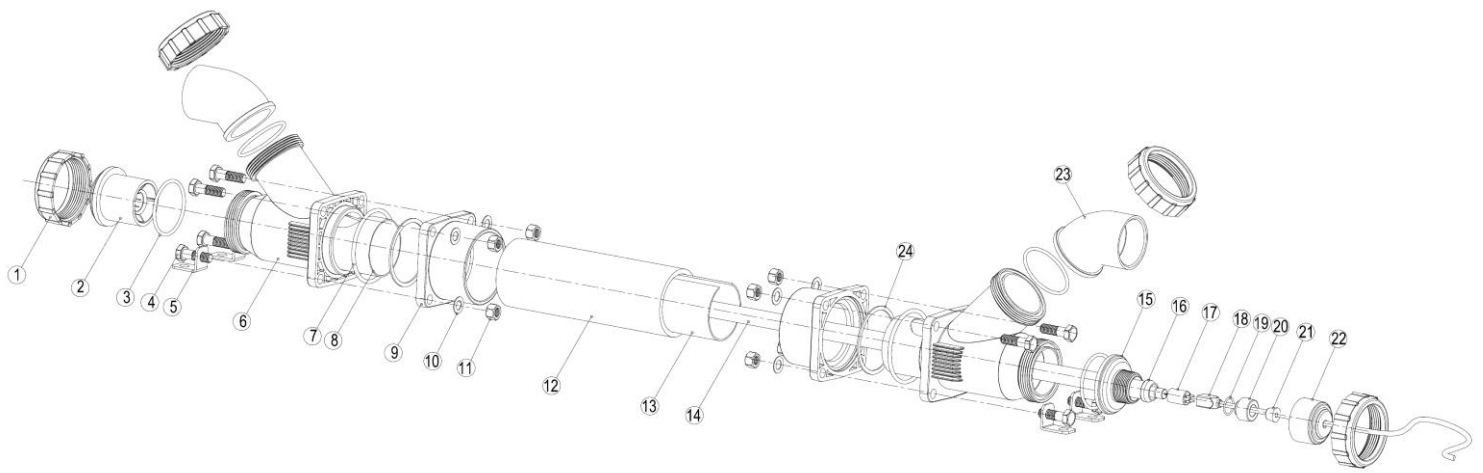

Replacement Parts – Match the parts to the diameter of your Pro Max UV 3” or 5”. Several parts are common

Part #	UPC 788379+	Drawing No.	Component Description List
R450208	318949	1	2" NUT PVC PLASTIC 3" or 5" Diameter
R450209	318956	2	UV END CAP PVC CLEAR PLASTIC 3" or 5" Diameter
R450210	318963	3	2" O-RING RUBBER 3" or 5" Diameter (Set of 4)
R450211	318970	4A	HOUSING BOLT STAINLESS STEEL (Set of 8) 5" Diameter
R450212	318987	4B	HOUSING BOLT STAINLESS STEEL (Set of 8) 3" Diameter
R450213	318994	5A	HOUSING CAP PVC PLASTIC 5" Diameter
R450214	319007	5B	HOUSING CAP PVC PLASTIC 3" Diameter
R450215	319014	6	HOUSING MOUNT STAINLESS STEEL (Set of 4) 3" or 5" Diameter
R450216	319021	7A	HOUSING CAP SLEEVE PVC PLASTIC 5" Diameter
R450217	319038	7B	HOUSING CAP SLEEVE PVC PLASTIC 3" Diameter
R450218	319045	8A	HOUSING O-RING RUBBER (Set of 2) 5" Diameter
R450219	319052	8B	HOUSING O-RING RUBBER (Set of 2) 3" Diameter
R450220	319069	9A	HOUSING FLANGE PVC PLASTIC 5" Diameter
R450221	319076	9B	HOUSING FLANGE PVC PLASTIC 3" Diameter
R450222	319083	10	HOUSING WASHER STAINLESS STEEL (Set of 16) 3" or 5" Diameter
R450223	319090	11	HOUSING LOCK NUT STAINLESS STEEL (Set of 8) 3" or 5" Diameter
R450224	319106	12A	HOUSING PVC PLASTIC 5" Diameter (NOT Replacable)
R450225	319113	12B	HOUSING PVC PLASTIC 3" Diameter (NOT Replacable)
R450226	319120	13A	HOUSING SLEEVE PVC PLASTIC 5" Diameter
R450227	319137	13B	HOUSING SLEEVE PVC PLASTIC 3" Diameter
R450228	319144	14A	UV QUARTZ SLEEVE 3" Diameter - Amalgam Germicidal UV Bulb-25 Watts
R450229	319151	14B	UV QUARTZ SLEEVE 3" Diameter - Amalgam Germicidal UV Bulb-40 Watts
R450203	318390	14C	UV QUARTZ SLEEVE 3" or 5" Diameter - Amalgam Germicidal UV Bulb-55 Watts
R450204	318406	14D	UV QUARTZ SLEEVE 3" or 5" Diameter - Amalgam Germicidal UV Bulb-90 Watts
R450205	318413	14E	UV QUARTZ SLEEVE 3" or 5" Diameter - Amalgam Germicidal UV Bulb-120 Watts
R450230	319199	15	UV CAP CLEAR BLUE PVC PLASTIC 3" or 5" Diameter
R450231	319205	16	UV BULB SLEEVE SEAL RUBBER 3" or 5" Diameter (1 Piece)
R175230DP	308346	17A	UV QUARTZ BULB 3" Diameter - Amalgam Germicidal UV Bulb-25 Watts
R175231DP	308353	17B	UV QUARTZ BULB 3" Diameter - Amalgam Germicidal UV Bulb-40 Watts
R450200	318369	17C	UV QUARTZ BULB 3" or 5" Diameter - Amalgam Germicidal UV Bulb-55 Watts
R450201	318376	17D	UV QUARTZ BULB 3" or 5" Diameter - Amalgam Germicidal UV Bulb-90 Watts
R450202	318383	17E	UV QUARTZ BULB 3" or 5" Diameter - Amalgam Germicidal UV Bulb-120 Watts
R450206	318420	18A	BALLAST FOR 3" Diameter - Amalgam Germicidal UV - 25, 40 Watts
R450207	318437	18B	BALLAST FOR 3" or 5" Diameter - Amalgam Germicidal UV - 55, 90, 120 Watts
R450232	319267	19	UV BULB SLEEVE O-RING RUBBER 3" or 5" Diameter
R450233	319274	20	UV BULB SLEEVE CAP PVC PLASTIC 3" or 5" Diameter
R450234	319281	21	RUBBER SEAL FOR BALLAST CABLE
R450235	319298	22	UV CAP NUT PVC PLASTIC 3" or 5" Diameter
R450236	319304	23	INLET/OUTLET PVC PLASTIC 3" or 5" Diameter
R450237	323493	24	Flat Gasket for 3" Pro-MAX UV Sterilizer (Added in 2019 and later production)
R450238	323509	24	Flat Gasket for 5" Pro-MAX UV Sterilizer (Added in 2019 and later production)