



**2020**

# **Powersports Battery**

## **Applications & Specifications**

# CONTENTS

## ABOUT YUASA BATTERY



01

## BATTERY TYPES



03

## HARDWARE / BATTERY TYPE NUMBERS



09

## UTV APPLICATIONS



28

18

## MOTORCYCLE APPLICATIONS



- 05 GYZ CUTAWAY DIAGRAM
- 06 YTZ CUTAWAY DIAGRAM
- 07 FEATURES AND BENEFITS
- 08 TERMINAL TYPES

- 10 AGM BATTERY SPECIFICATIONS
- 13 CONVENTIONAL BATTERY SPECIFICATIONS
- 15 TERMINALS & BATTERY LAYOUTS
- 17 JAPANESE TRACTOR SPECIFICATIONS  
BATTERY UPGRADE CROSS REFERENCE





**ATV APPLICATIONS**

**30**

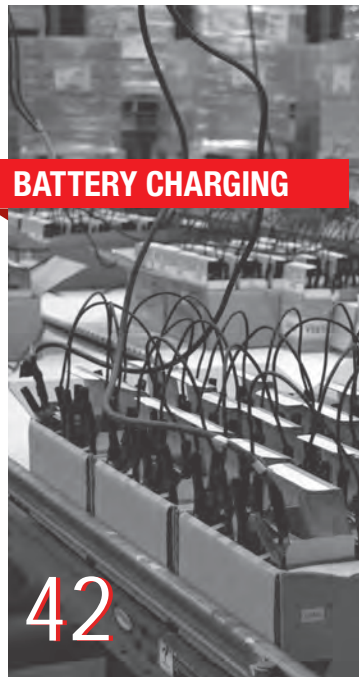

**BATTERY CHARGING**

**42**



**PWC APPLICATIONS**

**33**



**34**

**SNOW APPLICATIONS**



**BATTERY ACTIVATION**

**44**

- 29** SCOOTER APPLICATIONS
- 37** CONSUMER PRODUCTS
- 38** DIGITAL BATTERY TESTER
- 39** MERCHANDISING PRODUCTS

- 41** BATTERY SAFETY
- 47** BATTERY INSTALLATION / TESTING
- 48** DIGITAL PRINT TESTER INSTRUCTIONS
- 50** BATTERY MAINTENANCE / STORAGE

**DISCLAIMER**

The replacement battery information published in this book has been obtained from the equipment manufacturers listed, except as otherwise noted. Users are cautioned that the information contained in this book was the most current information provided to us at the time of publication. The information is subject to change upon notice from equipment manufacturers or field experience. Users should always use the most current edition of the Yuasa Battery Applications and Specifications. Yuasa expressly denies any responsibility for the accuracy of the information provided to us. While we have made every effort to accurately catalog the replacement battery information contained in this book, Yuasa denies any liability for damages as a consequence of using the information in this book. Users should also attempt to obtain replacement battery information from the equipment manufacturer's user manual or service department for their specific application.

# YUASA BATTERY

## THE PIONEER AND LEADER

### OF POWERSPORTS BATTERIES

# SINCE 1979

ADVANCED ENGINEERING, PREMIUM

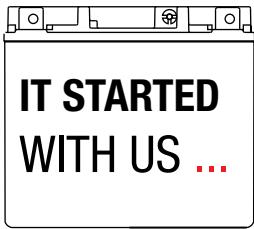

1981

• 1<sup>st</sup> OEM motorcycle battery YB14L-A2 to Honda



1985

• 1<sup>st</sup> OEM ATV battery YB14A-A2 to Polaris  
• 1<sup>st</sup> OEM snowmobile battery YB16L-B to Arctic Cat

1979

• 1<sup>st</sup> Conventional battery: 12N14-3A  
• 1<sup>st</sup> Yumicron battery: YB14L-A2



1983

• World's 1<sup>st</sup> maintenance-free AGM motorcycle battery: **YT series**



1987

• 1<sup>st</sup> OEM battery,



2008

• The most powerful, toughest AGM batteries for the American market: **GYZ series**  
• 1<sup>st</sup> OEM motorcycle battery GYZ20L for Honda GoldWing

2017

• 100<sup>th</sup> anniversary of Yuasa's parent, GS Yuasa  
"100 Years of History, 200 Years of Expertise"



2004

• 1<sup>st</sup> OEM motorcycle battery YTX20CH-BS to Suzuki



2011

• 1<sup>st</sup> OEM ATV battery GYZ16H to Honda



2019

• 40<sup>th</sup> anniversary of in the USA



## ⚡ Yuasa Battery Plant Facility

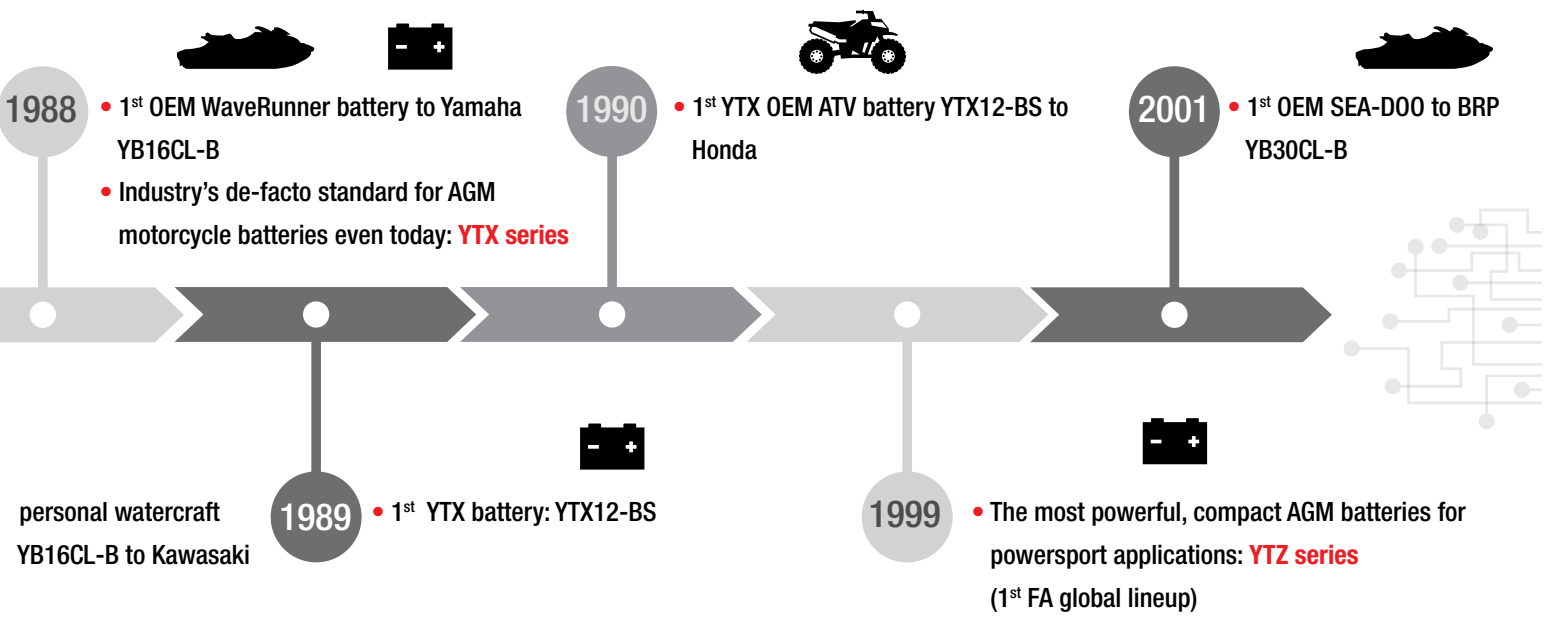
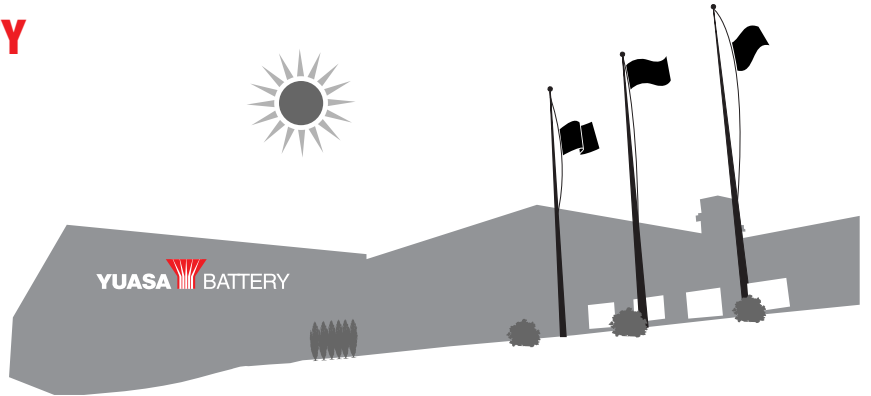

## 🔋 THE INDUSTRY STANDARD

Yuasa has set the standard by which all other powersports batteries are judged. It's why **more OEMs** and riders – in the US and worldwide – choose Yuasa.

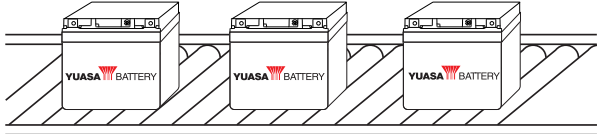

IT STILL STARTS WITH US ...



**40** INNOVATION  
manufacturing batteries

# BATTERY TYPES



## GYZ Series AGM

- AGM separators with superior grid designs for extreme vibration resistance
- More active material surface area for enhanced performance and power
- Supplied “Factory Activated” (nonspillable)
- Highest CCA motorcycle battery (500 CCA on GYZ32HL)
- Large heavy-duty flush terminals with multiple connections (GYZ32HL, GYZ20HL, GYZ20H, GYZ16HL)
- Built in brass nuts (GYZ32HL, GYZ20H, GYZ20HL, GYZ16HL)

## High Performance AGM

- All the features of a standard AGM battery plus increased power
- H Series: Increased power-up to 30% more cranking amps
- YTZ Series: Small size, lightweight, huge power













## AGM (Maintenance Free)

- Maintenance Free – no need to add water, but periodic charging required when not in use
- Absorbed Glass Mat (AGM) Separators – an advanced battery technology that eliminates the need to ever add water
- Advanced lead-calcium technology – holds its specific gravity more than 3 times longer than conventional lead antimony batteries

## Yumicron / Conventional

- Special thin separators – allow two extra plates per cell to be installed, for a 30% improvement in cranking performance
- Engineered to protect against corrosion, withstand vibration, and deliver high cranking power
- 6 volt and 12 volt varieties



GYZ	CAPACITY [AH]	CCA*	V-TWIN	ATV	UPGRADE FOR:	CAPACITY [AH]	CCA*
GYZ16H	16	240			YTX14	12	200
GYZ16HL**	16	240			YTX14L	12	200
GYZ20H	20	320			YTX20H	18	310
GYZ20HL	20	320			YTX20HL	18	310
GYZ32HL	32	500			YIX30L	30	400

\*CCA measured by BCI/SAE standard at 0° F.

\*\*Upgraded to built in brass nuts

## GYZ CUTAWAY DIAGRAM

**EZ Grip Cover:**  
simple installation  
(GYZ32HL)

**Large heavy-duty flush terminals:**  
constructed to allow multiple front and top connections, mounting position flexibility

**Built-in brass nuts:**  
up to 50% more conductive than stainless steel

**Enhanced active material:**  
compounded to withstand vibration, prolong battery life and dependability

**Absorbed Glass Mat (AGM) separators:**  
absorb electrolyte, making the battery nonspillable

**Protective separator material:**  
enhances vibration resistance

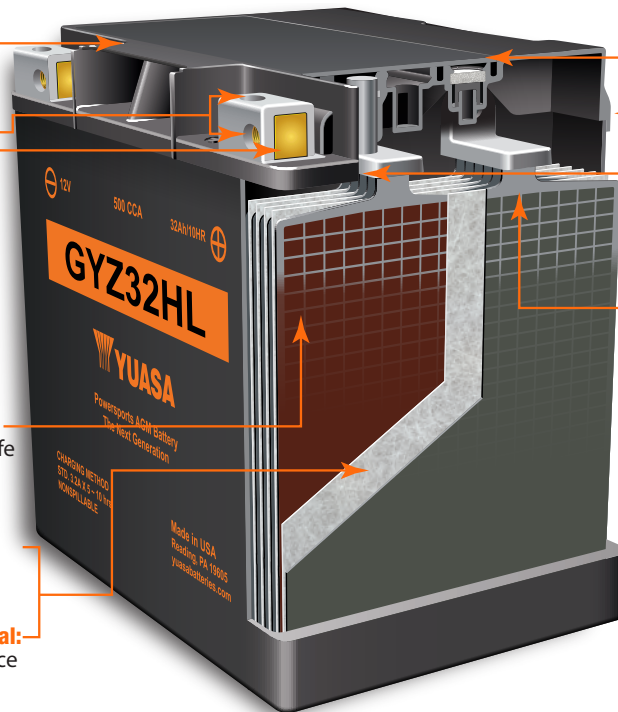





**Safety flame-arrestor:**  
leakproof valve relieves excess pressure

**Heat bonded cover:**  
eliminates leaks and corrosion

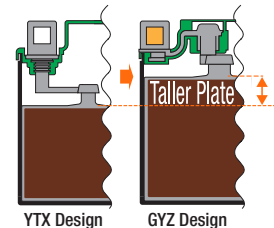
**Thru-partition construction:**  
provides shorter current path with less resistance than "over the partition" construction, resulting in more cranking power

**Taller plates:**  
extra surface area for more power: up to 500 CCA and 32 Ah to power more accessories



GYZ	CAPACITY [AH]	CCA*	METRIC	ATV	UPGRADE FOR:	CAPACITY [AH]	CCA*
GYZ16H	16	240			YTX14	12	200
GYZ20L	20	250			YTX20L	18	270

<b>YTZ</b>	<b>CAPACITY Ah (10HR)</b>	<b>CAPACITY Ah (20HR)</b>	<b>CCA*</b>	<b>Dimensions - Inches LxWxH (±1/16 in)</b>	<b>Dimensions - Millimeters LxWxH (±2 mm)</b>	<b>Approx. Weight with Acid (LBS)</b>	<b>Approx. Weight with Acid (KGS)</b>
<b>YTZ7S</b>	<b>6</b>	<b>6.3</b>	<b>130</b>	<b>4 7/16 x 2 3/4 x 4 1/8</b>	<b>113 x 70 x 105</b>	<b>4.6</b>	<b>2.1</b>
<b>YTZ10S</b>	<b>8.6</b>	<b>9.1</b>	<b>190</b>	<b>6 x 3 7/16 x 3 11/16</b>	<b>150 x 87 x 93</b>	<b>7.0</b>	<b>3.2</b>
<b>YTZ12S</b>	<b>11</b>	<b>11.6</b>	<b>210</b>	<b>6 x 3 7/16 x 4 3/8</b>	<b>150 x 87 x 110</b>	<b>8.2</b>	<b>3.7</b>
<b>YTZ14S</b>	<b>11.2</b>	<b>11.8</b>	<b>230</b>	<b>6 x 3 7/16 x 4 3/8</b>	<b>150 x 87 x 110</b>	<b>8.6</b>	<b>3.9</b>

\*CCA measured by BCI/SAE standard at 0° F.

## **YTZ CUTAWAY DIAGRAM**

### **HEAT SEALED CASE TO COVER**

Protects against leakage and corrosion and provides for extra strength and durability

### **SPECIAL ACTIVE MATERIAL**

Compounded to withstand vibration, it prolongs the battery life in storage and provides reliable starting power when needed

### **UNIQUE EXPANDED PLATE GRID DESIGN**

Increased number of plates for maximum starting power and to withstand severe vibration resistance

### **AGM SEPARATORS**

Absorbed Glass Matt separators absorb the electrolyte and make the battery spill-proof. The valve regulated design eliminates water loss and the need for refilling

### **POLYPROPYLENE (PP) COVER & CONTAINER**

Protects against fuel and oil and designed to withstand vibration and impact under extreme conditions

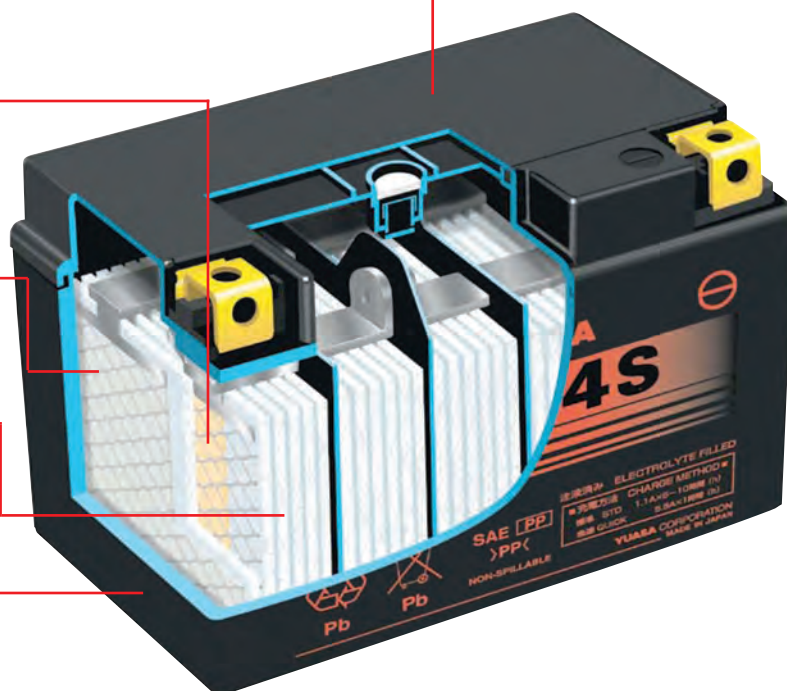

**LONGER BATTERY LIFE WITH  
MORE VOLUME EFFICIENCY**



# FEATURES AND BENEFITS

Components	Features	Benefits
<b>Cast grid</b>	Special grid design	Severe vibration resistance and improved conductivity
<b>Active material</b>	Proprietary formulation	Reduced shedding, maximum utilization and long service life
<b>Pasted plates</b>	Specified thickness and weight	Ensures vibration resistance through precise compression and proper service life through specified active material balance
<b>Dried-charged plates</b>	Tank formed and dried plates	Properly dried plates in a sealed battery have a virtually limitless shelf-life
<b>Top lead connections</b>	Through-partition construction, large straps	Shorter current path for increased electrical conductivity and higher starting currents, heavier parts for maximum durability
<b>Case-cover seal</b>	Thermal bonded plastic	Air tight seal to prevent air ingress and acid seepage
<b>Terminal-cover seal</b>	Patented poly-seal terminal	Eliminates acid seepage, reduces corrosion and extends battery life
<b>Case and cover</b>	Polypropylene	Superior resistance to gasoline and oil, impact resistant in extreme weather conditions
<b>Additive</b>	Sulfate stop (some models)	Sulfate stop added to reduce the solubility of lead into the acid, which then reduces battery sulfation potential
<b>Yumicron</b>		
<b>Separator</b>	Leaf or envelope separator	Polyethylene with glass mat sheet bonded for compression to withstand severe vibration conditions
<b>GYZ/YTX/High Performance AGM</b>		
<b>Separator</b>	AGM (absorbed glass mat)	High puncture resistant separator for increased service in high vibration applications
<b>Top lead alloy</b>	Calcium alloy	Increased weld strength and severe vibration resistance
<b>Vent system</b>	Valve and flame arrestor	Valve relieves excess pressure to prevent bursting, flame arrestor prevents internal combustion



Terminal shapes vary from one battery to another. By identifying the correct replacement battery from the listing in this book, you are assured of the proper terminal configuration. For custom applications, refer to the following chart to identify terminal shape and corresponding batteries.

Type	Terminal				Battery Type				
	Illustration	Front	Side	Top					
<b>1</b>					YB7C-A	YTX16-BS-1	YB14L-A1		
<b>2</b>					YB9L-A2	12N5.5-4A	YB16AL-A2		
<b>3</b>					12N24-3	12N24-3A	Y60-N24-A		
<b>4</b>					GYZ20L YB30L-B YTX15L-BS YTX20L-BS	Y50-N18L-A3 YIX30L-BS YTX16-BS YTX24HL-BS	YB12C-A YIX30L-BS-PW YTX20-BS YTX20HL-BS	YB16B-A YTX14AHL-B YTX20H-BS YIX20HL-BS	YB30CL-B YTX14AH-BS YTX20HL-BS-PW
<b>5</b>					GYZ16H GYZ16HL YB4L-B YTX14L-BS	YTX7L-BS KMX14-BS YT12A-BS YTX20CH-BS	YTX9-BS YB16C-B YTX12-BS YTX4L-BS	YTZ5S YTZ7S YB16CL-B YTX14-BS	YTX5L-BS YB4L-A YTX14H-BS YTX7A-BS
<b>6</b>					YB3L-A YB7L-B YB12A-A YB16-B 12N5-3B 12N7-4A 12N9-4B-1 6N6-3B	YB3L-B YB9A-A YB12AL-A YB-16-B-CX 12N5-4B 12N7-4B 12N10-3A 6N6-3B-1	YB5L-B YB9-B YB12AL-A2* YB16L-B 12N5.5-3B 12N7D-3B 6N11A-1B B54-6	YB7-A YB9L-B YB12A-B YB16HL-A-CX 12N5.5A-3B 12N12A-4A-1 6N11-2D B38-6A	YB7B-B YB10L-B YB14A-A1 SYB16L-B 12N7-3B 12N9-3B 6N12A-2D B39-6
<b>7</b>					HYB16A-AB Y50-N18A-A	YB16B-A1** Y50-N18L-A	YB18-A Y50-N18L-A-CX	YB18L-A SY50-N18L-AT	
<b>8</b>					YB10A-A2 YB14-A2 YB14-B2	YB10L-A2 YB14A-A2 YB14L-B2	YB10L-B2 YB14L-A2 12N14-3A	YB12B-B2 SYB14L-A2 12N11-3A-1	
<b>9</b>					YHD-12H				
<b>10</b>					51814	51913	53030	YT19BL-BS	
<b>11</b>					YT9B-BS YT7B-BS	YTZ10S YT12B-BS	YTZ12S	YTZ14S	YT14B-BS
					Note: Terminal is Brass Plated Steel				
<b>12</b>					YTR4A-BS				
<b>13</b>					YT4B-BS				
<b>14</b>					GYZ20H	GYZ32HL	GYZ20HL		
					Note: Encapsulated Brass Nut				

\* Includes terminal adapter for converting to top mount

\*\* Includes terminal adapter for converting to side mount

Part No.	Includes**	Fits				
<b>478030</b>	12mm lg. stainless steel hex bolt 20mm lg. stainless steel hex bolt 8mm stainless steel nut, lock washer and round brass spacer	YTX20-BS YTX20(H)L-BS-PW	YTX20L-BS	YTX20H-BS YB30CL-B	YTX20HL-BS YB30L-B	
<b>479100</b>	12mm lg. stainless steel hex bolt 5mm stainless steel rectangular nut	Y50-N18L-A3 YTX14H-BS	YTX9-BS YTX14AH-BS	YTX12-BS YTX14AHL-BS	YTX14-BS GYZ16H	YTX20CH YIX30L
<b>479862</b>	12mm lg. stainless steel hex bolt 8mm stainless steel rectangular nut	YTX15L-BS YTX24HL-BS	YTX20(H)-BS YIX20HL-BS	YIX30L-BS-PW YB30L-B	GYZ20L YB30CL-B	
<b>479102</b>	14mm lg. stainless steel hex bolt 5mm stainless steel square nut	YB16CL-B YTX14L	YB16C-B Y50-N18L-A-CX	Y50-N18L-A HYB16A-AB	YB18-A	
<b>479104</b>	12mm lg. stainless steel hex bolt 20mm lg. stainless steel hex bolt 5mm stainless steel nut, lock washer and round brass spacer	YTX14L-BS for Harley Davidson Sportster YTX14 <sup>FA</sup> for Harley Davidson V-ROD 02-07 YTX14H <sup>FA</sup> for Harley Davidson V-ROD 02-07 YTX12 YIX30L				
<b>479643</b>	12mm lg. stainless steel hex bolt 20mm lg. stainless steel hex bolt 8mm brass nut, lock washer and square brass spacer	YTX20H-BS	YTX20HL-BS	YTX24HL-BS	YIX30L-BS	
<b>479876</b>	12mm lg. stainless steel hex bolt 16mm lg. stainless steel hex bolt 5mm rectangular brass nut, lock washer and square brass spacer	GYZ16HL	YIX30L			
<b>479699</b>	12mm lg. stainless steel hex bolt and lock washer	GYZ20H	GYZ20HL	GYZ32HL		
<b>5BNBSSF6M</b>	11mm lg. stainless steel hex bolt 5mm stainless steel hex nut	YB14A-A1 YB14L-A2	YB14L-B2 YB14-A2	YB14A-A2 YB14-B2		
<b>5BNBSS14M</b>	14mm lg. stainless steel hex bolt 5mm stainless steel hex nut	12N74A YB18L-A	HYB16A-AB YHD-12H	YB16L-B Y50-N18L-A	YB18-A SY50-N18L-A	
<b>5BNBSS22M</b>	22mm lg. stainless steel hex bolt 5mm stainless steel hex nut and round brass spacer	YB16-B	YB16-B-CX	YB16HL-A-CX	YB16L-B	

\*\* All hardware listed above is M6 thread

<sup>FA</sup> Must use factory activated battery

## DESIGNATION OF BATTERY TYPE NUMBERS

### Conventional

**12 N 12A-4 A-1**

1 2 3 4 5 6

- 1 Nominal voltage
- 2 Conventional battery
- 3 Size of battery case
- 4 Polarity location
- 5 Exhaust location
- 6 Designates unique terminal

### High Performance Conventional

**YB 16A L-A2**

1 2 3 4

- 1 High Performance Conventional battery
- 2 Size of battery case
- 3 Polarity location
- 4 Terminal and Exhaust location

### AGM

**YTX 14 A H L-BS-1**

1 2 3 4 5 6 7

- 1 High Performance AGM (YTX, YIX, YTZ, YT, GYZ)
- 2 Performance classification
- 3 Designates unique battery case size
- 4 Higher CCA
- 5 Polarity location
- 6 Bottle supplied electrolyte
- 7 Designates unique terminal

## AGM, HIGH PERFORMANCE

FACTORY ACTIVATED (Non-Spillable)											12 VOLT		
Battery Type	Capacity Ah (10-HR)	Dimensions – Inches (± 1/16 in)			Dimensions – Millimeters (± 2 mm)			Assembly Figure (As Per Cover Polarity)	Approx Weight with Acid (lbs.)	Terminal Type (Refer to page 8)	Acid Volume (Liter)	Regular Charge Current (Amp)	C.C.A. @ 0 °F (-18 °C)
		L	W	H	L	W	H						
GYZ16H	16	6	3 7/16	5 3/4	150	87	145	⊕         ⊖	12.4	5	N/A	1.6	240
GYZ16HL	16	6	3 7/16	5 3/4	150	87	145	⊖         ⊕	12.4	5	N/A	1.6	240
GYZ20L	20	6 7/8	3 7/16	6 1/8	175	87	155	⊖         ⊕	15.2	4	N/A	2.0	250
GYZ20H	20	6 7/8	3 7/16	6 1/8	175	87	155	⊕         ⊖	15.7	14	N/A	2.0	320
GYZ20HL	20	6 7/8	3 7/16	6 1/8	175	87	155	⊖         ⊕	15.7	14	N/A	2.0	320
GYZ32HL	32	6 9/16	5	6 7/8	166	126	175	⊖         ⊕	24.7	14	N/A	3.2	500
YTX14AH *	12	5 5/16	3 1/2	6 9/16	134	89	166	⊕         ⊖	11.1	4	N/A	1.2	210
YTX14AHL	12	5 5/16	3 1/2	6 9/16	134	89	166	⊖         ⊕	11.1	4	N/A	1.2	210
YTX14H	12	6	3 7/16	5 3/4	150	87	145	⊕         ⊖	10.6	5	N/A	1.2	240
YTX20CH	18	6	3 7/16	6 3/8	150	87	161	⊕         ⊖	13.4	5	N/A	1.8	270
YTX20H	18	6 7/8	3 7/16	6 1/8	175	87	155	⊕         ⊖	15.1	4	N/A	1.8	310
YTX20HL	18	6 7/8	3 7/16	6 1/8	175	87	155	⊖         ⊕	15.1	4	N/A	1.8	310
YIX20HL	18	6 7/8	3 7/16	6 1/8	175	87	155	⊖         ⊕	15.1	4	N/A	1.8	320
YTX20HL-PW **	18	6 7/8	3 7/16	6 7/8 <sup>s</sup>	175	87	175 <sup>s</sup>	⊖         ⊕	15.1	4	N/A	1.8	310
YTX24HL	21	8 1/8	3 7/16	6 3/8	205	87	162	⊖         ⊕	17.5	4	N/A	2.1	350
YIX30L	30	6 9/16	5	6 7/8	166	126	175		22.0	4	N/A	3.0	400
YIX230L-PW	30	6 9/16	5	7 9/16 <sup>s</sup>	166	126	192 <sup>s</sup>		22.0	4	N/A	3.0	400
YTZ7S	6	4 7/16	2 3/4	4 1/8	113	70	105	⊖         ⊕	4.6	5	N/A	0.6	130
YTZ8V	7	4 7/16	2 3/4	5 1/8	113	70	130	⊖         ⊕	6.0	5	N/A	0.7	120
YTZ10S	8.6	6	3 7/16	3 11/16	150	87	93	⊕         ⊖	7.0	11	N/A	0.9	190
YTZ12S	11	6	3 7/16	4 3/8	150	87	110	⊕         ⊖	8.1	11	N/A	1.1	210
YTZ14S	11.2	6	3 7/16	4 3/8	150	87	110	⊕         ⊖	8.6	11	N/A	1.1	230

\* Includes 10mm height spacer for use in replacing YB14A-A1 and YB14A-A2  
 \*\* Includes 20mm height spacer (s) for use in replacing YB16CL-B  
 (s) Includes spacer



# BATTERY SPECIFICATIONS

## AGM, HIGH PERFORMANCE

### FRESH PACK (Battery Supplied Dry with an Acid Bottle)

### 12 VOLT

Battery Type	Capacity Ah (10-HR)	Dimensions – Inches (± 1/16 in)			Dimensions – Millimeters (± 2 mm)			Assembly Figure (As Per Cover Polarity)	Approx Weight with Acid (lbs.)	Terminal Type (Refer to page 8)	Acid Volume (Liter)	Regular Charge Current (Amp)	C.C.A. @ 0 °F (-18 °C)
		L	W	H	L	W	H						
YTZ5S-BS	3.5	4 7/16	2 3/4	3 3/8	113	70	86		3.5	5	0.20	0.4	65
YTX14AH-BS *	12	5 5/16	3 1/2	6 9/16	134	89	166		11.1	4	0.66	1.2	210
YTX14AHL-BS	12	5 5/16	3 1/2	6 9/16	134	89	166		11.1	4	0.66	1.2	210
YTX14H-BS	12	6	3 7/16	5 3/4	150	87	145		10.6	5	0.69	1.4	240
YTX20CH-BS	18	6	3 7/16	6 3/8	150	87	161		13.4	5	0.82	1.8	270
YTX20H-BS	18	6 7/8	3 7/16	6 1/8	175	87	155		15.1	4	0.93	1.8	310
YTX20HL-BS	18	6 7/8	3 7/16	6 1/8	175	87	155		15.1	4	0.93	1.8	310
YTX20HL-BS-PW **	18	6 7/8	3 7/16	6 7/8 <sup>§</sup>	175	87	175 <sup>§</sup>		15.1	4	0.93	1.8	310
YIX20HL-BS	18	6 7/8	3 7/16	6 1/8	175	87	175		15.1	4	0.93	1.8	320
YTX24HL-BS	21	8 1/8	3 7/16	6 3/8	205	87	162		17.5	4	1.08	2.1	350
YIX30L-BS	30	6 9/16	5	6 7/8	166	126	175		22.0	4	1.4	3.0	400
YIX30L-BS-PW**	30	6 9/16	5	6 3/8	166	126	192 <sup>§</sup>		22.0	4	1.4	3.0	400

- \* Includes 10mm height spacer for use in replacing YB14A-A1 and YB14A-A2
- \*\* Includes 20mm height spacer (°) for use in replacing YB16CL-B
- (°) Includes spacer

## AGM

### FACTORY ACTIVATED (Non-Spillable)

### 12 VOLT

Battery Type	Capacity Ah (10-HR)	Dimensions – Inches (± 1/16 in)			Dimensions – Millimeters (± 2 mm)			Assembly Figure (As Per Cover Polarity)	Approx Weight with Acid (lbs.)	Terminal Type (Refer to page 8)	Acid Volume (Liter)	Regular Charge Current (Amp)	C.C.A. @ 0 °F (-18 °C)
		L	W	H	L	W	H						
YTX9	8	6	3 7/16	4 3/16	150	87	105		6.6	5	N/A	0.9	135
YTX12	10	6	3 7/16	5 1/8	150	87	130		9.2	5	N/A	1.2	180
YT12B	10	6	2 3/4	5 1/8	150	69	130		9.2	5	N/A	1.2	210
YTX14	12	6	3 7/16	5 3/4	150	87	145		10.1	5	N/A	1.4	200
YTX14L	12	6	3 7/16	5 3/4	150	87	145		10.1	5	N/A	1.4	200
YTX15L	13	6 7/8	3 7/16	5 1/8	175	87	130		11.0	4	N/A	1.3	230
YTX20	18	6 7/8	3 7/16	6 1/8	175	87	155		13.9	4	N/A	1.8	270
YTX20L	18	6 7/8	3 7/16	6 1/8	175	87	155		13.9	4	N/A	1.8	270
YIX30L	30	6 9/16	5	6 7/8	166	126	175		22.0	4	N/A	3	400
YIX30L-PW Δ	30	6 9/16	5	7 9/16 <sup>§</sup>	166	126	192 <sup>§</sup>		22.0	4	N/A	3.0	400

- K Available at Kawasaki dealers only
- Δ Includes 17mm height spacer (°) for replacing YB30CL-B
- (°) Includes spacer

### FRESH PACK (Battery Supplied Dry with an Acid Bottle)

### 12 VOLT

Battery Type	Capacity Ah (10-HR)	Dimensions – Inches (± 1/16 in)			Dimensions – Millimeters (± 2 mm)			Assembly Figure (As Per Cover Polarity)	Approx Weight with Acid (lbs.)	Terminal Type (Refer to page 8)	Acid Volume (Liter)	Regular Charge Current (Amp)	C.C.A. @ 0 °F (-18 °C)
		L	W	H	L	W	H						
YTR4A-BS	2.3	4 1/2	1 15/16	3 3/8	114	49	86		2.4	12	0.14	0.3	45
YT4B-BS	2.3	4 1/2	1 9/16	3 7/16	114	39	86.5		2.4	13	0.12	0.3	40
YTX4L-BS	3	4 1/2	2 13/16	3 3/8	114	71	86		3.4	5	0.18	0.4	50
YTX5L-BS	4	4 1/2	2 13/16	4 3/16	114	71	106		4.2	5	0.24	0.5	80
YT7B-BS	6.5	6	2 9/16	3 11/16	150	65	93		5.9	11	0.33	0.7	120
YTX7A-BS	6	6	3 7/16	3 3/4	150	87	94		6.3	5	0.33	0.7	105
YTX7L-BS	6	4 1/2	2 13/16	5 3/16	114	71	131		6.1	5	0.33	0.6	100
YT9B-BS	8	6	2 3/4	4 1/8	150	70	105		8.7	11	0.40	0.8	120
YTX9-BS	8	6	3 7/16	4 3/16	150	87	105		6.6	5	0.40	0.9	135
YT12A-BS	10	6	3 7/16	4 3/16	150	87	105		7.7	5	0.47	1.0	175
YT12B-BS	10	6	2 3/4	5 1/8	150	69	130		9.0	11	0.52	1.0	210
YTX12-BS	10	6	3 7/16	5 1/8	150	87	130		9.2	5	0.60	1.2	180
KMX14-BS <sup>K</sup>	12	6	3 7/16	5 3/4	150	87	145		10.1	5	0.69	1.4	200
YT14B-BS	12	6 1/8	2 3/4	5 3/4	150	70	145		11.8	11	0.60	1.2	210
YTX14-BS	12	6	3 7/16	5 3/4	150	87	145		10.1	5	0.69	1.4	200
YTX14L-BS	12	6	3 7/16	5 3/4	150	87	145		10.1	5	0.69	1.4	200
YTX15L-BS	13	6 7/8	3 7/16	5 1/8	175	87	130		11.0	4	0.69	1.3	230
YTX16-BS	14	6	3 7/16	6 3/8	150	87	161		12.6	4	0.78	1.4	230
YTX16-BS-1	14	6	3 7/16	6 3/8	150	87	161		12.6	1	0.78	1.4	230
YT19BL-BS	17.7	7 1/4	3 3/16	6 11/16	184	81	170		12.5	10	0.95	1.8	170
YTX20-BS	18	6 7/8	3 7/16	6 1/8	175	87	155		13.9	4	0.93	1.8	270
YTX20L-BS	18	6 7/8	3 7/16	6 1/8	175	87	155		13.9	4	0.93	1.8	270
YIX30L-BS	30	6 9/16	5	6 7/8	166	126	175		22.0	4	1.40	3.0	400
YIX30L-BS-PW <sup>Δ</sup>	30	6 9/16	5	7 9/16 <sup>§</sup>	166	126	192 <sup>§</sup>		22.0	4	1.40	3.0	400

<sup>K</sup> Available at Kawasaki dealers only  
<sup>Δ</sup> Includes 17mm height spacer (<sup>§</sup>) for replacing YB30CL-B  
<sup>§</sup> Includes spacer

# BATTERY SPECIFICATIONS

## HIGH PERFORMANCE, CONVENTIONAL (Yumicron)

## 12 VOLT

Battery Type	Capacity Ah (10-HR)	Dimensions – Inches (± 1/16 in)			Dimensions – Millimeters (± 2 mm)			Assembly Figure (As Per Cover Polarity)	Approx Weight w/out Acid (lbs.)	Terminal Type (Refer to page 8)	Acid Volume (oz.)	Regular Charge Current (Amp)
		L	W	H	L	W	H					
YB2.5L-C	2.5	3 3/16	2 3/4	4 1/8	80	70	105		1.7	-	8.1	0.3
YB2.5L-C-1	2.5	3 3/16	2 3/4	4 1/8	80	70	105		1.7	-	8.1	0.3
YB3L-A	3	3 7/8	2 1/4	4 3/8	98	56	110		2.5	6	8.1	0.3
YB3L-B	3	3 7/8	2 1/4	4 3/8	98	56	110		2.5	6	8.1	0.3
YB4L-A	4	4 3/4	2 3/4	3 5/8	120	70	92		2.8	5	10.1	0.4
YB4L-B	4	4 3/4	2 3/4	3 5/8	120	70	92		2.8	5	10.1	0.4
YB5L-B	5	4 3/4	2 3/8	5 1/8	120	60	130		3.5	6	12.2	0.5
YB6L-B <sup>D4</sup>	6	5 1/2	2 7/8	3 17/18	138	72.5	100		3.5	6	12.2	0.5
YB7-A	8	5 5/16	3	5 1/4	135	75	133		5.1	6	20.3	0.8
YB7B-B	7	6	2 3/8	5 1/8	150	60	130		4.0	6	16.9	0.7
YB7C-A	8	5 1/8	3 9/16	4 1/2	130	90	114		5.1	1	20.3	0.8
YB7L-B	8	5 5/16	3	5 1/4	135	75	133		5.1	6	20.3	0.8
YB9A-A	9	5 5/16	3	6 1/8	135	75	155		5.3	6	20.3	0.9
YB9L-A2	9	5 5/16	3	5 1/2	135	75	139		5.3	2	20.3	0.9
YB9-B	9	5 5/16	3	5 1/2	135	75	139		5.3	6	20.3	0.9
YB9L-B	9	5 5/16	3	5 1/2	135	75	139		5.3	6	20.3	0.9
YB10A-A2	11	5 5/16	3 9/16	6 1/8	135	90	155		7.0	8	27.0	1.1
YB10L-A2	11	5 5/16	3 9/16	5 3/4	135	90	145		7.0	8	27.0	1.1
YB10L-B	11	5 5/16	3 9/16	5 3/4	135	90	145		7.0	6	27.0	1.1
YB10L-B2	11	5 5/16	3 9/16	5 3/4	135	90	145		7.0	8	27.0	1.1
YB12A-A	12	5 5/16	3 3/16	6 5/16	134	80	160		6.8	6	27.0	1.2
YB12A-A <sup>▲</sup>	12	5 5/16	3 3/16	6 5/16	134	80	160		6.8	6	27.0	1.2
YB12A-A <sup>**</sup>	12	5 5/16	3 3/16	6 5/16	134	80	160		6.8	6	27.0	1.2
YB12AL-A <sup>D</sup>	12	5 5/16	3 3/16	6 5/16	134	80	160		6.8	6	25.4	1.2
YB12AL-A	12	5 5/16	3 3/16	6 5/16	134	80	160		6.8	6	25.4	1.2
YB12AL-A2 <sup>*</sup>	12	5 5/16	3 3/16	6 5/16	134	80	160		6.8	8	25.4	1.2
YB12A-B	12	5 5/16	3 3/16	6 5/16	134	80	160		6.8	6	25.4	1.2
YB12B-B2	12	6 5/16	3 9/16	5 1/8	160	90	130		7.1	8	27.0	1.2
YB12C-A	12	5 5/16	3 9/16	6 7/8	134	80	175		7.1	4	27.0	1.2
YB14-A2	14	5 5/16	3 1/2	6 9/16	134	89	166		7.6	8	30.4	1.4
YB14A-A1	14	5 5/16	3 1/2	6 15/16	134	89	176		7.9	6	30.4	1.4
YB14A-A2	14	5 5/16	3 1/2	6 15/16	134	89	176		7.9	8	30.4	1.4
YB14L-A1	14	5 5/16	3 1/2	6 9/16	134	89	166		7.6	1	30.4	1.4

\* Includes terminal adaptor for converting to top mount.  
 \*\* When ordering this battery, specify terminal adaptor.  
 ▲ When ordering this battery, specify sensor.

<sup>D</sup> Discontinued, use YB12AL-A2  
<sup>D4</sup> Discontinued



## HIGH PERFORMANCE, CONVENTIONAL (Yumicron)

## 12 VOLT

Battery Type	Capacity Ah (10-HR)	Dimensions – Inches (± 1/16 in)			Dimensions – Millimeters (± 2 mm)			Assembly Figure (As Per Cover Polarity)	Approx Weight w/out Acid (lbs.)	Terminal Type (Refer to page 8)	Acid Volume (oz.)	Regular Charge Current (Amp)
		L	W	H	L	W	H					
YB14L-A2	14	5 5/16	3 1/2	6 9/16	134	89	166		7.6	8	30.4	1.4
YB14L-A2 <sup>D5</sup>	14	5 5/16	3 1/2	6 9/16	134	89	166		7.6	8	30.4	1.4
YB14L-B2	14	5 5/16	3 1/2	6 9/16	134	89	166		7.6	8	30.4	1.4
YB14-B2	14	5 5/16	3 1/2	6 9/16	134	89	166		7.6	8	30.4	1.4
SYB14L-A2 †	14	5 5/16	3 1/2	6 9/16	134	89	166		7.6	8	30.4	1.4
SYB14L-B2 <sup>D1</sup> †	14	5 5/16	3 1/2	6 9/16	134	89	166		7.6	8	30.4	1.4
YB16AL-A2	16	8 1/8	2 13/16	6 7/16	207	71.5	164		8.6	2	37.2	1.6
HYB16A-AB	16	6	3 5/8	7 1/16	151	91	180		8.5	7	30.4	1.6
YB16-B	19	6 7/8	4	6 1/8	175	100	155		10.5	6	40.6	1.9
YB16-B-CX	19	6 7/8	4	6 1/8	175	100	155		10.5	6	40.6	1.9
YB16HL-A-CX	19	6 7/8	4	6 1/8	175	100	155		10.5	6	40.6	1.9
YB16L-B	19	6 7/8	4	6 1/8	175	100	155		10.5	6	40.6	1.9
YB16B-A	16	6 5/16	3 9/16	6 3/8	160	90	161		8.4	4	33.8	1.6
YB16B-A1*	16	6 5/16	3 9/16	6 3/8	160	90	161		8.4	7	33.8	1.6
YB16C-B	19	6 7/8	4	6 7/8	175	100	175		10.1	5	40.6	1.9
YB16CL-B	19	6 7/8	4	6 7/8	175	100	175		10.1	5	40.6	1.9
SYB16L-B <sup>D2</sup> †	19	6 15/16	4	6 1/8	175	100	155		9.3	6	43.9	1.9
YB18-A	18	7 1/8	3 9/16	6 3/8	180	90	162		9.4	7	40.6	1.8
YB18L-A	18	7 1/8	3 9/16	6 3/8	180	90	162		9.4	7	40.6	1.8
Y50-N18A-A	20	8 1/8	3 9/16	6 15/16	205	90	176		11.2	7	50.7	2.0
Y50-N18L-A	20	8 1/8	3 9/16	6 3/8	205	90	162		11.2	7	44.0	2.0
Y50-N18L-A-CX	20	8 1/8	3 9/16	6 3/8	205	90	162		11.2	7	44.0	2.0
Y50-N18L-A3	20	8 1/8	3 9/16	6 3/8	205	90	162		11.2	4	44.0	2.0
SY50-N18L-AT †	20	8 1/8	3 9/16	6 3/8	205	90	162		11.2	7	44.0	2.0
Y60-N24-A <sup>D4</sup>	28	7 1/4	4 7/8	6 7/8	184	124	175		14.4	3	57.5	2.8
Y60-N24AL-B <sup>D3</sup>	28	7 1/4	4 7/8	6 7/8	184	124	175		14.4	3	57.5	2.8
YB30L-B	30	6 5/8	5 3/16	6 15/16	168	132	176		14.1	4	57.5	3.0
YB30CL-B	30	6 5/8	5 3/16	7 9/16	168	132	192.2		14.5	4	57.5	3.0
51814	19 ***	7 7/16	3 1/4	6 7/8	186	82	171		9.4	10	33.8	1.9
51913	19 ***	7 7/16	3 1/4	6 7/8	186	82	171		9.4	10	33.8	1.9
53030	30 ***	7 7/16	5 1/8	6 7/8	186	130	171		16.1	10	54.1	3.0

<sup>D1</sup> Discontinued, use YB14L-B2  
<sup>D2</sup> Discontinued, use YB16L-B  
<sup>D3</sup> Discontinued, use 53030  
<sup>D4</sup> Discontinued

<sup>D5</sup> Discontinued, use SYB14L-A2 built in sensor  
<sup>†</sup> This battery includes a sensor  
<sup>\*</sup> Includes terminal adaptor for converting to side mount  
<sup>\*\*\*</sup> DIN Standard @ 20 hr. rate

# BATTERY SPECIFICATIONS

## CONVENTIONAL

## 6 VOLT

Battery Type	Capacity Ah (10-HR)	Dimensions – Inches (± 1/16 in)			Dimensions – Millimeters (± 2 mm)			Assembly Figure (As Per Cover Polarity)	Approx Weight w/out Acid (lbs.)	Terminal Type (Refer to page 8)	Acid Volume (oz.)	Regular Charge Current (Amp)
		L	W	H	L	W	H					
6N2-2A	2	2 3/4	1 7/8	3 3/4	70	47	96		1.0	-	3.4	0.2
6N2-2A-1 <sup>D4</sup>	2	2 3/4	1 7/8	3 3/4	70	47	96		1.0	-	3.4	0.2
6N2-2A-3	2	2 3/4	1 7/8	3 3/4	70	47	96		1.0	-	3.4	0.2
6N2-2A-4	2	2 3/4	1 7/8	3 3/4	70	47	96		1.0	-	3.4	0.2
6N2-2A-8	2	2 3/4	1 7/8	3 3/4	70	47	96		1.0	-	3.4	0.2
6N2A-2C	2	2 3/4	1 7/8	4 3/16	70	47	106		1.0	-	3.4	0.2
6N2A-2C-1 <sup>**</sup>	2	2 3/4	1 7/8	4 3/16	70	47	106		1.0	-	3.4	0.2
6N2A-2C-3	2	2 3/4	1 7/8	4 3/16	70	47	106		1.0	-	3.4	0.2
6N4-2A	4	2 13/16	2 13/16	3 3/4	71	71	96		1.3	-	6.8	0.4
6N4-2A-4	4	2 13/16	2 13/16	3 3/4	71	71	96		1.3	-	6.8	0.4
6N4-2A-5	4	2 13/16	2 13/16	3 3/4	71	71	96		1.3	-	6.8	0.4
6N4-2A-6	4	2 13/16	2 13/16	3 3/4	71	71	96		1.3	-	6.8	0.4
6N4-2A-8	4	2 13/16	2 13/16	3 3/4	71	71	96		1.3	-	6.8	0.4
6N4A-4D	4	2 3/8	2 1/4	5 1/8	61	57	131		1.7	-	6.8	0.4
6N4B-2A	4	4	1 7/8	3 3/4	102	48	96		1.7	-	6.8	0.4
6N4B-2A-3	4	4	1 7/8	3 3/4	102	48	96		1.7	-	6.8	0.4
6N4B-2A-5	4	4	1 7/8	3 3/4	102	48	96		1.7	-	6.8	0.4
6N4C-1B	4	2 13/16	2 13/16	4 1/8	71	71	105		1.4	-	6.8	0.4
6N5.5-1D	5.5	3 9/16	2 3/4	3 15/16	90	70	100		1.8	-	10.1	0.6
6N6-3B	6	3 7/8	2 1/4	4 3/8	99	57	111		2.0	6	10.1	0.6
6N6-3B-1	6	3 7/8	2 1/4	4 3/8	99	57	111		2.0	6	10.1	0.6
6N6-1D-2	6	3 7/8	2 1/4	4 3/8	99	57	111		2.0	-	10.1	0.6
6N11-2D	11	5 7/8	2 3/4	3 15/16	150	70	100		3.5	6	13.5	1.1
6N11A-1B	11	4 13/16	2 7/16	5 1/8	122	62	131		3.5	6	13.5	1.1
B54-6 <sup>D4</sup>	12	6 1/8	2 1/4	4 9/16	156	57	116		3.8	6	16.9	1.2
6N12A-2D	12	6 1/8	2 1/4	4 9/16	156	57	116		3.8	6	15.2	1.2
B38-6A	13	4 11/16	3 1/4	6 15/16	119	83	161		4.7	6	21.0	1.3
6YB8L-B <sup>D4</sup>	8	4 3/4	2 3/4	3 3/4	120	70	95		3.0	6	10.5	0.8
6YB11-2D <sup>D4</sup>	11	5 7/8	2 3/4	3 15/16	150	70	100		4.4	6	13.5	1.1

<sup>\*\*</sup> 6N2A-2C-1 replaces B60-6  
<sup>D4</sup> Discontinued

# TRACTOR TERMINALS & BATTERY LAYOUTS

## CONVENTIONAL

## 12 VOLT

Battery Type	Capacity Ah (10-HR)	Dimensions – Inches (± 1/16 in)			Dimensions – Millimeters (± 2 mm)			Assembly Figure (As Per Cover Polarity)	Approx Weight w/out Acid (lbs.)	Terminal Type (Refer to page 8)	Acid Volume (oz.)	Regular Charge Current (Amp)
		L	W	H	L	W	H					
12N5-3B	5	4 3/4	2 3/8	5 1/8	120	60	130		3.1	6	13.5	0.5
12N5-4B	5	4 3/4	2 3/8	5 1/8	120	60	130		3.1	6	13.5	0.5
12N5.5-3B	5.5	5 5/16	2 3/8	5 1/8	135	60	130		4.3	6	13.5	0.6
12N5.5-4A	5.5	5 5/16	2 3/8	5 1/8	135	60	130		4.3	2	13.5	0.6
12N5.5A-3B	5.5	4 1/16	3 9/16	4 1/2	103	90	114		4.3	6	16.9	0.6
12N7-3B	7	5 5/16	3	5 1/4	135	75	133		4.9	6	16.9	0.7
12N7-4A	7	5 5/16	3	5 1/4	135	75	133		4.9	6	16.9	0.7
12N7-4B	7	5 5/16	3	5 1/4	135	75	133		4.9	6	16.9	0.7
12N7D-3B	7	5 5/16	3	5 15/16	135	75	150		4.9	6	20.3	0.7
12N9-3A	9	5 5/16	3	5 1/2	135	75	139		5.4	9	20.3	0.9
12N9-3A-1 <sup>D6</sup>	9	5 5/16	3	5 1/2	135	75	139		5.4	6	20.3	0.9
12N9-3B <sup>D7</sup>	9	5 5/16	3	5 1/2	135	75	139		5.4	6	20.3	0.9
12N9-4B-1	9	5 5/16	3	5 1/2	135	75	139		5.4	6	20.3	0.9
12N10-3A-2 <sup>D8</sup>	10	5 5/16	3 9/16	5 3/4	135	90	145		5.8	8	27.0	1.0
12N12A-4A-1	12	5 5/16	3 3/16	6 5/16	134	80	160		6.8	6	23.7	1.2
12N14-3A	14	5 5/16	3 1/2	6 9/16	134	89	166		7.5	8	27.0	1.4
12N24-3A <sup>D4</sup>	24	7 1/4	4 7/8	6 7/8	184	124	175		12.1	3	40.6	2.4
12N24-3	24	7 1/4	4 7/8	6 7/8	184	124	175		12.1	3	40.6	2.4
YHD-12H	29	8 1/8	5 1/4	6 1/2	206	133	165		13.3	9	67.6	2.8

<sup>D4</sup> Discontinued  
<sup>D6</sup> Discontinued, use YB9L-A2

<sup>D7</sup> Discontinued, use YB9L-B  
<sup>D8</sup> Discontinued, use YB10L-A2

# TRACTOR TERMINALS & BATTERY LAYOUTS

## TERMINALS (measurements in inches)

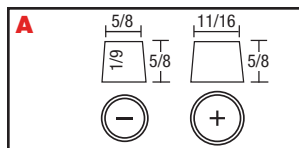

Standard Terminal

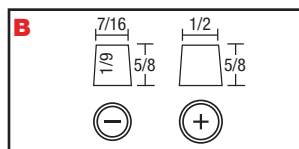

Small Terminal

## BATTERY LAYOUTS

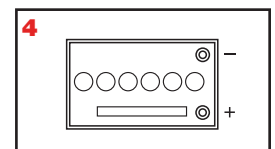
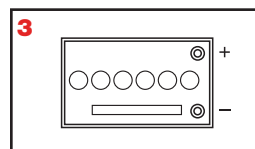
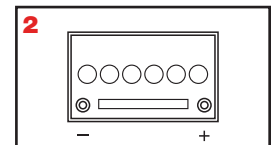
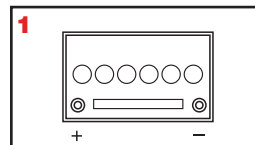



# JAPANESE TRACTOR BATTERY SPECIFICATIONS

JIS Type	Reference Number	Plate / Cell	Capacity Ah ▲ (5 hr)	Capacity Ah ▲ (20 hr)	Cranking Performance ▲ (Amps 0 °F)	Reserve Capacity Minutes (80 °F)	Overall Dimensions (inches)			Shipping Weight Dry (lbs.)	Volume Of Acid (oz.)	Charging Current (Amp)	See Key	
							L	W	H				Terminal	Layout
*36B20L (S)	40B19L(S) NS40ZL(S)	9	28	35	275	52	7 3/4	5 1/16	8 15/16	17.9	84.6	3.5	A	2
46B24R	NS60	13	36	45	330	75	9 3/8	5 1/16	8 15/16	20.1	109.0	4.5	B	1
*46B24L (S)	NS60L(S)	13	36	45	330	75	9 3/8	5 1/16	8 15/16	20.1	109.5	4.5	A	2
36B20L	40B19L/NS40ZL	9	28	35	275	52	7 3/4	5 1/16	8 15/16	17.9	91.7	3.5	B	2
*55B24L (S) D4	NX100S6L(S)	13	36	45	410	70	9 3/8	5 1/16	8 15/16	21.3	109.3	4.5	A	2
95E41R	N100	17	80	100	475	200	16 3/8	6 15/16	9 3/8	38.1	233.1	10	A	1
115F51	N120	21	96	120	420	240	19 7/8	7 3/16	10 1/8	48.7	317.4	12.0	A	3
115F51L D4	N120L	21	96	120	420	240	19 7/8	7 3/16	10 1/8	48.7	317.4	12.0	A	4
145F51	NS150	25	120	150	760	296	19 7/8	7 3/16	10 1/8	56.2	370.3	14.0	A	3
145G51L D4	N150L D4	23	120	150	685	240	20 3/16	8 3/4	10 1/8	63.8	337.8	15	A	4

\* (S) Signifies Standard Terminal  
D4 Discontinued

▲ Figures based on JIS/SAE specifications and reference only

# BATTERY UPGRADE CROSS REFERENCE

GYZ Series	AGM Factory Activated	AGM High Performance	AGM	Yumicron	Conventional
-	-	-	-	6YB11-2D	6N11-2D
-	-	YTZ5S-BS	YTX4L-BS	YB4L-A, YB4L-B	-
-	YTZ7S	-	YTX5L-BS	-	-
-	-	-	-	YB5L-B	12N5-3B
-	-	YTZ8V	YTX7L-BS	-	-
-	-	-	-	YB7L-B	12N7-3B
-	-	-	-	YB7-A	12N7-4A
-	-	-	-	YB9-B	12N9-4B-1
-	-	-	-	YB9L-B	12N9-3B (Discontinued)
-	-	-	-	YB10L-A2	12N10-3A-2 (Discontinued)
-	-	-	-	YB12A-A	12N12A-4A-1
GYZ16H	YTX14H	YTX14H-BS	YTX14-BS	-	-
-	YTX14AH	YTX14AH-BS	-	YB14-A2, YB14-B2	-
-	YTX14AH <sup>3,4</sup>	YTX14AH-BS <sup>3,4</sup>	-	YB14A-A1, YB14A-A2	-
-	YTX14AHL	YTX14AHL-BS	-	YB14L-A2	12N14-3A
-	YTX14AHL	YTX14AHL-BS	-	YB14L-B2	-
GYZ16HL	YTX14L	-	YTX14L-BS	-	-
-	-	-	YT19BL-BS	51913, 51814	-
-	YTX20CH	YTX20CH-BS	YTX16-BS	-	-
GYZ20H <sup>7</sup>	YTX20H <sup>7</sup> , YTX20 <sup>2</sup>	YTX20H-BS <sup>2</sup>	YTX20-BS <sup>2</sup>	YB16-B, YB16-B-CX	-
GYZ20H	YTX20H, YTX20 <sup>2</sup>	YTX20H-BS <sup>2</sup>	YTX20-BS <sup>2</sup>	YB18-A	-
-	YTX20HL-PW <sup>8</sup>	YTX20HL-BS-PW <sup>8</sup>	-	YB16CL-B	-
GYZ20HL <sup>7</sup> , GYZ20L	YTX20HL, YTX20L	YTX20HL-BS	YTX20L-BS	YB16HL-A-CX	-
GYZ20HL, GYZ20L	YTX20HL, YTX20L <sup>2</sup>	YTX20HL-BS <sup>2</sup>	YTX20L-BS <sup>2</sup>	YB16L-B	-
GYZ20HL, GYZ20L	YTX20HL, YTX20L <sup>2</sup>	YTX20HL-BS <sup>2</sup>	YTX20L-BS <sup>2</sup>	YB18L-A	-
GYZ20HL <sup>8</sup> , GYZ20L	YTX20HL, YTX20L	YTX20HL-BS <sup>2</sup>	YTX20L-BS	-	-
-	YTX24HL <sup>3</sup>	YTX24HL-BS <sup>3</sup>	-	Y50-N18L-A, Y50-N18L-A-CX	-
-	YTX24HL	YTX24HL-BS	-	Y50-N18-A3	-
-	YTX24HL <sup>1,3</sup>	YTX24HL-BS <sup>1,3</sup>	-	SY50-N18-AT	-
-	YIX20HL <sup>9</sup>	YIX20HL-BS <sup>9</sup> > YTX20HL-BS	-	-	-
-	YIX30L <sup>9</sup>	YIX30L-BS <sup>9</sup>	-	YB30L-B	-
GYZ32HL	YIX30L <sup>9</sup>	YIX30L-BS <sup>9</sup>	-	YB30CLB	-
-	YIX30L-PW <sup>5,9</sup>	YIX30L-BS-PW <sup>5,9</sup>	-	53030	Y60-N24L-B (Discontinued)
-	YIX30L <sup>9</sup>	YIX30L-BS <sup>9</sup>	-	-	-

1 Eliminates need for sensor (needs to be disabled).

2 The YTX20 series batteries may be used as an optional upgrade, but some modification to the hold down may be necessary. See battery label for retrofit cautions.

3 Top and front terminal mounts only.

4 Includes 10mm height spacer.

5 Includes 17mm height spacer.

6 Includes 20mm height spacer for use in replacing YB16CL-B.

7 For Harley-Davidson Models only.

8 GYZ20HL has flush terminals, different than OEM battery on Honda GL1800.

9 Preferred cold climate performance.

CC	Model	Year	GYZ Series AGM	High Performance AGM	AGM	Yumicron / Conventional
<b>APRILIA</b>						
1200	Dorsoduro, Caponord	'11-'17	GYZ16H	YTX14H-BS	YTX14-BS	-
1100	Tuono V4 1100, RR	'14-'18	-	-	YT12A-BS	-
1000	RSV4 R, Factory	'09-'15	-	YTZ10S	-	-
	ETV Caponord	'01-'07	GYZ16H	YTX14H-BS	YTX14-BS	-
	RST Futura	'01-'04	-	-	YTX12-BS	-
	RSV 1000, Mille SP	'98-'99	-	-	YTX12-BS	-
	RSV 1000 R, Factory	'04-'11	-	-	YTX12-BS	-
	RSV 1000 Mille, R	'00-'09	-	-	YTX12-BS	-
	Tuono 1000 R, Factory	'03-'11	-	-	YTX12-BS	-
	Tuono V4R	'11-'14	-	-	YT12A-BS	-
	SL Falco	'00-'03	GYZ16H	YTX14H-BS	YTX14-BS	-
900	Dorsoduro	'07	GYZ16H	YTX14H-BS	YTX14-BS	-
	Shiver	'17	GYZ16H	YTX14H-BS	YTX14-BS	-
850	Mana 850, GT	'07-'16	GYZ16H	YTX14H-BS	YTX14-BS	-
750	Shiver	'07-'09	GYZ16H	YTX14H-BS	YTX14-BS	-
	Shiver	'10-'16	-	-	YTX12-BS	-
	Dorsoduro	'09-'16	GYZ16H	YTX14H-BS	YTX14-BS	-
650	Pegaso	'92-'96	-	YTX14AHL-BS	-	SYB14L-A2 †
	Pegaso	'97-'04	-	-	-	YB12AL-A2
	Pegaso Strada, Factory, Trail	'05-'12	-	-	YTX12-BS	-
	Moto-65	'95-'99	-	-	-	YB12AL-A2
550	RXV550	'10	-	-	YTX7A-BS	-
	SVX550	'10	-	-	YTX7A-BS	-
500	Scarabeo	'04-'05	-	YTX14AHL-BS	-	-
	Atlantic	'03-'05	-	YTX14AHL-BS	-	-
450	RXV450	'10	-	-	YTX7A-BS	-
	SVX450	'10	-	-	YTX7A-BS	-
250	RS250	'00-'04	-	-	YB4L-B	-
200	Atlantic	'04-'05	-	-	YB12AL-A2	-
150	Scarabeo	'00-'04	-	-	YB12AL-A2	-
	Mojito	'04-'05	-	YTZ8V	YTX7L-BS	-
125	RS125	'11	-	-	-	YB9-B*
	RS4 125	'11-'13	-	YTZ8V	YTX7L-BS	-
50	RS50	'00-'05	-	-	YB4L-B	-
	RS4 50	'11-'13	-	YTZ7S	YTX5L-BS	-
	SR50	'00-'01	-	-	YB4L-B	-
	SR50 Ditech	'01-'05	-	YTZ7S	YTX5L-BS	-
	Scarabeo 50	'00-'03	-	-	YB4L-B	-
	Mojito	'04-'05	-	-	YB4L-B	-
	Rally	'04-'05	-	-	YB4L-B	-

<b>ATK</b>						
	All Electric Start Models	'91-'95	-	-	YTX9-BS	-
	All Electric Start Models	'96-'01	-	YTZ8V	YTX7L-BS	-

<b>BENELLI</b>						
900	900 (6 Cilindri)	-	GYZ32HL	YX30L-BS	-	53030
650	650 Tornado U.T.	-	-	-	YB12A-A*	-
250	250 (4 Cilindri)	-	-	-	YB12A-A*	-
	250-2C	-	-	-	6N11A-1B	-
125	125 Cross	-	-	-	6N11A-1B	-
	125 Custom Guzzi	-	-	-	12N5.5-4A	-
	125 Guzzi	-	-	-	12N5.5-4A	-
	125 Jarno (c/aw.)	-	-	-	YB9-B*	-
	125 Scooter Benelli	-	-	-	YB9L-B*	-
	125-2 CSE	-	-	-	6N11A-1B	-
	125CS	-	-	-	YB9-B*	-
	125T Sport	-	-	-	6N11A-1B	-
50	Devil 50 (c/aw.)	-	-	-	YB4L-B	-
	KBX 50 Race	-	-	-	YB4L-B	-
	Scooty LX/DLX	-	-	-	YB4L-B	-

<b>BIG DOG</b>						
	All Models	All Years	-	YTX20HL-BS	-	-

<b>BIMOTA</b>						
1100	SB6, SB7	'95-'97	-	-	YTX7L-BS (x2)	-
	SB6R	'97-'99	-	-	YTX12-BS	-
1000	YB8/YB10	'92-'95	-	YTX14AHL-BS	-	SYB14L-A2 †
	YB11	'96-'99	-	-	YTX12-BS	-
996	SB8R, SB8RS	'98-'00	-	-	YTX12-BS	-
900	DB2	'93-'95	-	YTX14AH-BS	-	YB14-A2
	DB2 Final Edition	'97	-	YTX14AH-BS	-	YB14-A2

CC	Model	Year	GYZ Series AGM	High Performance AGM	AGM	Yumicron / Conventional
	DB3 Mantra	'97-'99	-	-	YTX7L-BS (x2)	-
	DB4	'98-'00	Not Available	-	-	-
	Tesi	'91-'95	-	-	YTX14AH-BS	YB14-A2

<b>BMW</b>						
1600	K1600GT, GTL	'11-'17	-	-	YT19BL-BS	51913
	K1600 Bagger	'17	-	YTX20CH-BS	YTX16-BS	-
1300	K1300GT	'09-'11	-	-	YT19BL-BS	51913
	K1300R, S	'09-'16	GYZ16H	YTX14H-BS	YTX14-BS	-
1200	R1200S, R	'05-'16	GYZ16H	YTX14H-BS	YTX14-BS	-
	R1200GS	'05-'13	GYZ16H	YTX14H-BS	YTX14-BS	-
	R1200GSW	'13-'17	-	-	YTZ14S	-
	R1200GS Adventure	'08-'17	-	-	YTZ14S	-
	R1200RS	'14-'18	GYZ16H	YTX14H-BS	YTX14-BS	-
	K1200LT, GT	'05-'09	-	-	YT19BL-BS	51913
	R1200RT	'05-'13	-	-	YT19BL-BS	51913
	R1200RT	'14-'18	-	YTX20CH-BS	YTX16-BS	-
	K1200LT, GT, RS, S	'99-'05	-	-	YT19BL-BS	51913
	K1200RS	'97-'05	-	-	YT19BL-BS	51913
	R1200C	'98-'05	-	-	YT19BL-BS	51913
	HP2 Sport / Megamoto / Enduro	'05-'11	-	YTZ14S	-	-
	R nineT, Scrambler, Pure, Racer, Urban	'13-'19	GYZ16H	YTX14H-BS	YTX14-BS	-
	R1200ST	'05-'07	GYZ16H	YTX14H-BS	YTX14-BS	-
1150	R1150GS, R	'00-'05	-	-	YT19BL-BS	51913
	R1150R, RS, RT	'01-'06	-	-	YT19BL-BS	51913
1100	K1100LT/RS	'90-'95	-	-	YT19BL-BS	51913
	R1100GS	'94-'00	-	-	YT19BL-BS	51913
	R1100R	'94-'00	-	-	YT19BL-BS	51913
	R1100RS, RT	'93-'00	-	-	YT19BL-BS	51913
	R1100S, ABS	'98-'05	-	-	YT19BL-BS	51913
1000	All "K" Models	'83-'93	GYZ32HL	YX30L-BS	-	53030
	R100/7	'76-'84	GYZ32HL	YX30L-BS	-	53030
	R100GS, PD, R, RS, RT	'87-'95	GYZ32HL	YX30L-BS	-	53030
	R100GS	'76-'84	GYZ32HL	YX30L-BS	-	53030
	HP4 (w/ alarm system)	'13-'14	-	YTZ10S	-	-
	HP4 (w/o alarm system)	'13-'14	-	YTZ7S	-	-
	S1000R	'14-'17	-	YTZ10S	-	-
	S1000RR	'09-'13	-	YTZ10S	-	-
	S1000RR DWA	'09-'11	-	YTZ12S	-	-
	S1000RR	'14-'16	-	YTZ7S	-	-
	S1000RR DWA	'14-'16	-	YTZ10S	-	-
	S1000XR	'16-'17	-	-	YTX9-BS	-
	S1000XR DWA	'16	-	YTZ10S	-	-
900	R90/6, R90S	'69-'76	GYZ32HL	YX30L-BS	-	53030
850	R850R	'95-'97	-	-	YT19BL-BS	51913
800	F800ST, GS, GT, R, ADV	'07-'18	GYZ16H	YTX14H-BS	YTX14-BS	-
	F800GT (auxiliary battery)	'13-'16	-	YTZ14S	-	-
	R80, R80RT	'84-'95	GYZ32HL	YX30L-BS	-	53030
	R80GS, R80ST	'80-'96	-	-	YT19BL-BS	51814
	R80/7, R80RT	'78-'84	GYZ32HL	YX30L-BS	-	53030
798	F700GS	'11-'18	GYZ16H	YTX14H-BS	YTX14-BS	-
	F700GS (auxiliary battery)	'11-'18	-	YTZ14S	-	-
750	K75, RT	'85-'95	GYZ32HL	YX30L-BS	-	53030
	K75	'85-'86	-	-	YT19BL-BS	51814
	K75	'87-'92	-	-	-	52515*
	K75	'93-'95	-	-	YT19BL-BS	51913
	K75C	'85-'86	-	-	YT19BL-BS	51814
	K75C	'87-'93	-	-	-	52515*
	K75C	'85-'95	-	-	YT19BL-BS	51814
	K75RT	'92-'96	-	-	YT19BL-BS	51913
	K75S	'85-'86	-	-	YT19BL-BS	51814
	K75S	'87-'92	-	-	-	52515*
	R75/5	'70-'73	-	-	YT19BL-BS	51814
	R75/7	'76-'84	GYZ32HL	YX30L-BS	-	53030
	R75/6	'69-'76	GYZ32HL	YX30L-BS	-	53030
700	R69 - R69S	'55-'69	-	-	-	B38-6A
650	F650, G650GS	'93-'16	-	-	-	YB12AL-A2
	F650GS	'07-'12	GYZ16H	YTX14H-BS	YTX14-BS	-
	G650 X, Challenge, Country, Moto	'06-'09	-	YTZ10S	-	-
	R65	'84-'95	GYZ32HL	YX30L-BS	-	53030
	R65LS	'78-'84	-	-	YT19BL-BS	51814
600	R60, R60/2 Twin Cylinders	'55-'69	-	-	-	B38-6A
	R60/5	'70-'73	-	-	YT19BL-BS	51814
	R60/6, R60/7	'69-'84	GYZ32HL	YX30L-BS	-	53030
500	R50/2 Twin Cylinders	'55-'69	-	-	-	B38-6A
	R50/5	'70-'73	-	-	YT19BL-BS	51814

\* See Battery Cross Reference Chart on page 17  
 † This battery includes a sensor  
 ‡ 52515 not available in USA

Ⓒ YTX20 series batteries may be used as an optional upgrade, but some modification to the hold down may be necessary. See battery label for retrofit cautions.  
 (x2) Order two batteries

# MOTORCYCLE APPLICATIONS

CC	Model	Year	GYZ Series AGM	High Performance AGM	AGM	Yumicron / Conventional
	R50/S Twin Cylinders	'55-'69	-	-	-	B38-6A
450	G450	'09-'11	-	YTZ7S	-	-
310	G 310 R, GS	'16-'19	-	-	YTX9-BS	-
260	R26, R27 Single Cylinder	'55-'69	-	-	-	6N11A-1B
	R 26	-	-	-	-	B38-6A

## BRP (CAN-AM)

1330	Spyder (RT, F3)	'14-'19	-	YTX24HL	-	-
998	Spyder (RS)	'08-'16	-	YTX24HL	-	-
900	Ryker (ACE)	'19-'20	GYZ16HL*	-	YTX14L	-
600	Ryker (ACE)	'19-'20	GYZ16HL*	-	YTX14L	-

## BSA

	250, 350, 400, 441, 500 (12V)	-	-	-	-	YB7-A*
	600, 650, 750 (12V)	-	-	-	-	YB7-A*
	250, 350, 650 (6V)	-	-	-	-	B39-6
	500 Gold Star	-	-	-	-	B38-6A
	Rocket 750, Thunderbolt	-	-	-	-	YB9L-B*
	Spitfire HK35, Starfire B25	-	-	-	-	YB9L-B*

## BUELL

1200	X1 Lightning	'99-'02	GYZ20HL	YTX20HL <sup>FA</sup>	YTX20L <sup>FA</sup>	-
	S1 Lightning	'96-'99	-	YTX14H-BS <sup>FA</sup>	YTX14-BS <sup>FA</sup>	-
	S3, S3T Thunderbolt	'97-'02	GYZ20HL	YTX20HL-BS	YTX20L-BS	-
	M2 Cyclone	'97-'02	GYZ20HL	YTX20HL-BS	YTX20L-BS	-
	S2, S2T Thunderbolt	'94-'96	GYZ20H	YTX20H-BS	YTX20-BS	YB16-B-CX
	RR1200	'88-'90	GYZ20H	YTX20H-BS	YTX20-BS	YB16-B-CX
	RS1200	'89-'93	GYZ20H	YTX20H-BS	YTX20-BS	YB16-B-CX
	RSS1200	'91-'93	GYZ20H	YTX20H-BS	YTX20-BS	YB16-B-CX
	XB12R Firebolt	'04-'10	GYZ16H	YTX14H <sup>FA</sup>	YTX14 <sup>FA</sup>	-
	XB12Ss, Scoj, Lightning	'04-'10	GYZ16H	YTX14H <sup>FA</sup>	YTX14 <sup>FA</sup>	-
	XB12X, XT Ulysses	'06-'10	GYZ16H	YTX14H <sup>FA</sup>	YTX14 <sup>FA</sup>	-
1125	1125R, 1125CR	'08-'10	GYZ16HL	-	YTX14L <sup>FA</sup>	-
	Buell Racing 1125RR	'09	-	YTZ7S	YTX5L-BS	-
1000	RR1000	'87	GYZ20H	YTX20H-BS	YTX20-BS	YB16-B-CX
984	XB9R Firebolt, XB9SX Lightning	'02-'10	GYZ16H	YTX14H <sup>FA</sup>	YTX14 <sup>FA</sup>	-
500	Blast	'00-09	GYZ16H	YTX14H-BS	YTX14-BS	-

## CAGIVA

900	Elefant E900	-	-	-	-	YB16B-A1
750	Elefant	'94-'97	GYZ20H	YTX20H-BS	YTX20-BS	YB16-B-CX
	Elefant Bifaro	'89	-	YTX14AHL-BS	-	SYB14L-A2†
500	T4 E Elefant	'88-	-	YTX14AHL-BS	-	SYB14L-A2†
350	Elefant 2 Cyl.	'86-	-	YTX14AHL-BS	-	SYB14L-A2†
	T4 E Elefant, W12	'87-	-	YTX14AHL-BS	-	SYB14L-A2†
	T4R	'87-	-	-	YB3L-A	-
125	Crouser	'87-'88	-	-	YB9-B*	-
	Freccia C9, C10R, C12R	'87-'90	-	-	YB9-B*	-
	Mito	'90-'97	-	-	YB9-B*	-
	N 90	'97	-	-	YB9-B*	-
	Roadster	'94-'97	-	-	YB9-B*	-
	Supercity	'91-'97	-	-	YB9-B*	-
50	City, Lucky, Explorer	'94-'97	-	YTZ5S-BS	YTX4L-BS	-
	K3, W4	'98	-	-	-	YB4L-B

## CANNONDALE

440	C440, E440, S440, X440, X440S	'02-'03	-	YTZ7S	YTX5L-BS	-
	EX400, MX400, XC400	'00-'01	-	YTZ7S	YTX5L-BS	-

## CCM

600	All Electric Start Models	'96-'01	-	-	YTX9-BS	-
-----	---------------------------	---------	---	---	---------	---

## DERBI

	All Models	-	-	-	-	YB4L-B
--	------------	---	---	---	---	--------

## DUCATI

1299	Superbike 1299 Panigale, S	'15-'16	-	-	YT7B-BS	-
1262	Diavel, S	'16-'18	-	-	YT12B-BS	-
	Multiestrada 1260	'18	-	-	YT12B-BS	-
1200	Multiestrada	'10-'18	-	-	YT12B-BS	-
	Monster 1200	'14-'18	-	-	YT12B-BS	-
1199	1199, Panigale, (S)	'11-'14	-	-	YT7B-BS	-

CC	Model	Year	GYZ Series AGM	High Performance AGM	AGM	Yumicron / Conventional
1198	1198, MY08, SP, R	'09-'11	-	-	-	YT12B-BS
	Diavel	'11-'17	-	-	-	YT12B-BS
	1198 Panigale R	'16	Not available	-	-	-
1100	Monster 1100	'09-'13	-	-	-	YT12B-BS
	Multiestrada	'07-'09	-	-	-	YT12B-BS
	Hypermotard	'07-'13	-	-	-	YT12B-BS
	Street Fighter, S	'09-'12	-	-	-	YT12B-BS
1098	1098	'07-'09	-	-	-	YT12B-BS
	1098	'07	GYZ16H	YTX14H-BS	YTX14-BS	-
	Various All other models	'01-'10	-	-	-	YT12B-BS
1000	Desmosedici RR	'08-'09	-	-	-	YT12B-BS
	GT1000, Touring, Sport 1100S	'09	-	-	-	YT12B-BS
	Monster S2R	'05-'07	-	-	-	YT12B-BS
998	998, 999	'02-'07	-	-	-	YT12B-BS
996	996, S, SPS	'99-'00	-	-	-	YB16A-L-A2
959	959 Panigale	'16-'18	-	-	-	YT7B-BS
944	Sport Touring 2 (ST2)	'97-'00	-	-	-	YB16A-L-A2
	Sport Touring 2 (ST2)	'01-'03	-	-	-	YT12B-BS
937	Hypermotard 939	'16-'18	-	-	-	YT12B-BS
	Hyperstrada 939	'16-'18	-	-	-	YT12B-BS
	Multiestrada 950	'17-'18	-	-	-	YT12B-BS
916	916 Biposto, Senna, Strada	'94-'98	-	-	-	YB16A-L-A2
	I.E., SP, SP S	'94-'98	-	-	-	YB16A-L-A2
	ST4	'99-'00	-	-	-	YB16A-L-A2
907	I.E. Paso	'90-'94	GYZ20H	YTX20H-BS	YTX20-BS	YB16-B
906	Paso	'90-'92	GYZ20H	YTX20H-BS	YTX20-BS	YB16-B
900	Monster	'94-'00	-	-	-	YB16A-L-A2
	SS Kick-Starter	'81	-	-	-	YB12A-A
	SS Replica	'81	-	-	-	YB12A-A
	SS Supersport, Replica	'82-	-	YTX14AHL-BS	-	SYB14L-A2†
	SS	'89-'00	-	-	-	YB16A-L-A2
	SL	'92-'96	-	-	-	YB16A-L-A2
	Supersport FE	'97-'98	-	-	-	YB16A-L-A2
888	SP, SP II, SP IV, SP V	'90-'95	-	-	-	YB16A-L-A2
860	GT, GTS	-	GYZ32HL	YX30L-BS	-	53030
	Kick-Start	-	-	-	-	YB12A-A
851	851 Superbike	'90-'91	-	-	-	YB16A-L-A2
	S Superbike	'91-'92	-	-	-	YB16A-L-A2
848	848, Corse SE	'08-'13	-	-	-	YT12B-BS
	Street Fighter	'13	-	-	-	YT12B-BS
821	Monster	'14-'18	-	-	-	YT12B-BS
803	Scrambler	'15-'16	-	-	-	YT12B-BS
	Monster 797	'17-'18	-	-	-	YT12B-BS
796	Hypermotard	'10-'13	-	-	-	YT12B-BS
	Monster 796	'10-'13	-	-	-	YT12B-BS
750	F1, Montjuich, Paso	'87-'90	-	YTX14AHL-BS	-	SYB14L-A2†
	GT, Luguna Seca	-	GYZ32HL	YX30L-BS	-	53030
	Indiana	-	-	YTX14AHL-BS	-	SYB14L-A2†
	Monster	'97-'00	-	-	-	YB16A-L-A2
	Sport	'89-'90	-	-	-	YB16A-L-A2
	SS Supersport Kick-Str.	-	-	-	-	YB12A-A
	SS	'90-'00	-	-	-	YB16A-L-A2
748	748 Strada Biposto, SP, SPS	'97-'00	-	-	-	YB16A-L-A2
696	Monster 696	'08-'13	-	-	-	YT12B-BS
650	Alazzurra, Indiana, Pantah	-	-	YTX14AHL-BS	-	SYB14L-A2†
600	Pantah	-	-	YTX14AHL-BS	-	SYB14L-A2†
	TL	-	-	YTX14AHL-BS	-	SYB14L-A2†
500	GTL, GTV	-	-	YTX24HL-BS*	-	Y50-N18L-A
	Pantah	-	-	YTX14AHL-BS	-	SYB14L-A2†
	Sport	-	-	YTX24HL-BS*	-	Y50-N18L-A
399	Scrambler Sixty2	'16	-	-	-	YT12B-BS

## EXCELSIOR-HENDERSON

1386 (85)	Super X	'99-'00	GYZ20HL	YTX20HL-BS	YTX20L-BS	-
-----------	---------	---------	---------	------------	-----------	---

## GAS GAS

450	FSR450	'08	-	YTZ7S	YTX5L-BS	-
370	Pampera	'97	-	YTZ5S-BS	YTX4L-BS	-
320	Pampera	'98-'01	-	YTZ5S-BS	YTX4L-BS	-
250	Pampera	'96-'01	-	YTZ5S-BS	YTX4L-BS	-

## GILERA

600	Nordwest	'93	-	YTX14AHL-BS	-	SYB14L-A2†
	RC 600C	'93	-	YTX14AHL-BS	-	SYB14L-A2†

## Must use adapter kit available from Buell  
 \* See Battery Cross Reference Chart on page 17  
 † Top and front terminal mounts only

FA Must use factory activated battery  
 † This battery includes a sensor



CC	Model	Year	GYZ Series AGM	High Performance AGM	AGM	Yumicron / Conventional	CC	Model	Year	GYZ Series AGM	High Performance AGM	AGM	Yumicron / Conventional	
	Top Rally, XRT	-	-	YTX14AHL-BS	-	SYB14L-A2*	(88)	FXST, FLST Series (Softail)	'00-'06	GYZ20HL	YTX20HL-BS	YTX20L-BS	-	
500	Dakota Kick-Start	-	-	-	-	12N5.5-3B		FL, FLH Series (Touring)	'00-'06	GYZ32HL	YX30L-BS	-	YB30L-B	
	Dakota E-Starter	-	-	-	-	YB10L-A2		FL, FLH Series (Touring)	'99	GYZ32HL	YX30L-BS	-	YB30L-B	
350	Dakota Kick-Start	-	-	-	-	12N5.5-3B	1340	FXD/FXST Series (Dyna)	'97-'99	GYZ20HL	YTX20HL-BS	YTX20L-BS	-	
	Dakota E-Starter	-	-	-	-	YB10L-A2	(80)	FXD/FXST Series (Dyna)	'91-'96	GYZ20HL	YTX20HL-BS	YTX20L-BS	YB16HL-A-CX	
	ER Kick-Start	-	-	-	-	12N5.5-3B		FX/FXR Series	'79-'94	GYZ20H	YTX20H-BS	YTX20L-BS	YB16-B-CX	
	ER E-Starter	-	-	-	-	YB10L-A2		FXR Series	'99-'00	GYZ20H	YTX20H-BS	YTX20L-BS	YB16-B-CX	
	XRT	-	-	YTX14AHL-BS	-	SYB14L-A2*		FLST Series (Softail)	'97-'99	GYZ20HL	YTX20HL-BS	YTX20L-BS	-	
250	Arizona Rally	-	-	-	-	YB10L-B		FLST Series (Softail)	'91-'96	GYZ20HL	YTX20HL-BS	YTX20L-BS	YB16HL-A-CX	
	RV NGR Kick-Start	-	-	-	-	12N5.5-3B		FXST/FLST Series (Softail)	'84-'90	GYZ20HL	YTX20H-BS	YTX20L-BS	YB16-B-CX	
	RV NGR E-Start	-	-	-	-	YB10L-B		FL, FLH Series (Touring)	'85-'96	-	YTX24HL-BS *	-	Y50-N18L-A-CX	
200	Arizona	-	-	-	-	12N5.5-3B		FL, FLH Series (Touring)	'97-'98	GYZ32HL	YX30L-BS	-	YB30L-B	
	Arizona	-	-	-	-	YB9-B*		FL, FLH Series (Touring)	'78-'84	-	-	-	YHD-12H	
	Fast Bike	-	-	-	-	12N5.5-3B	1250	VRSC V-Rod	'07-'17	GYZ20HL	YTX20HL <sup>FA</sup>	YTX20L <sup>FA</sup>	-	
	Fast Bike	-	-	-	-	YB9-B*		VRSC V-Rod	'06	GYZ16H	YTX14H <sup>FA</sup>	-	-	
	RTX, RV, RX Kick-Start	-	-	-	-	12N5.5-3B	1200	XL, XLH (Sportster)	'04-'19	GYZ16HL	-	YTX14L-BS	-	
	RTX, RV, RX E-Starter	-	-	-	-	YB9-B*		XL, XLH (Sportster)	'97-'03	-	YTX20HL-BS <sup>C</sup>	YTX20L-BS <sup>C</sup>	-	
	T4	-	-	-	-	12N5.5-3B		XL, XLH (Sportster)	'87-'96	-	YTX20H-BS <sup>C</sup>	-	YB16-B-CX	
	Motocarro	-	-	-	-	B38-6A		XR1200X	'09-'12	GYZ16HL	-	YTX14L-BS	-	
125	Apache Kick-Start	-	-	-	-	12N5.5-3B		FX Series (Electric Start)	'71-'78	-	YTX20H-BS <sup>C</sup>	YTX20L-BS <sup>C</sup>	YB16-B-CX	
	Apache E-Starter	-	-	-	-	YB9-B*		FX Series (Kick Start)	'71-'72	-	-	-	YB7-A*	
	Arizona Kick-Start	-	-	-	-	12N5.5-3B		FL/FLH Series (Touring)	'65-'77	-	-	-	YHD-12H	
	Arizona E-Starter	-	-	-	-	YB9-B*	1130	VRSC V-Rod	'02-'06	GYZ16H	YTX14H <sup>FA</sup>	-	-	
	Crona Kick-Start	-	-	-	-	12N5.5-3B		VRSCR	'07	GYZ16H	YTX14H <sup>FA</sup>	YTX14 <sup>FA</sup>	-	
	Crona E-Starter	-	-	-	-	YB9-B*	1100	XL Series (Sportster)	'87-'93	GYZ20H	YTX20H-BS <sup>C</sup>	YTX20L-BS <sup>C</sup>	YB16-B-CX	
	CX Kick-Start	-	-	-	-	12N5.5-3B	1000	XL Series (Sportster)	'79-'85	GYZ20H	YTX20H-BS <sup>C</sup>	YTX20L-BS <sup>C</sup>	YB16-B-CX	
	CX E-Starter	-	-	-	-	YB9-B*		XLCH Series (Sportster Kick Start)	'70-'78	-	-	-	YB7-A*	
	Fast Bike Kick-Start	-	-	-	-	12N5.5-3B		XLCR Cafe Racer	'77-'78	GYZ20H	YTX20H-BS <sup>C</sup>	YTX20L-BS <sup>C</sup>	YB16-B-CX	
	Fast Bike E-Starter	-	-	-	-	YB9-B*		XLH (Sportster Electric Start)	'67-'78	-	-	-	YHD-12H	
	Freestyle Kick-Start	-	-	-	-	12N5.5-3B		1000 XLX-61, XR1000	'83-'85	GYZ20H	YTX20H-BS <sup>C</sup>	YTX20L-BS <sup>C</sup>	YB16-B-CX	
	Freestyle E-Starter	-	-	-	-	YB9-B*	883	XL, XLH (Sportster)	'04-'19	GYZ16HL	-	YTX14L-BS	-	
	GFR Kick-Start	-	-	-	-	12N5.5-3B		XL, XLH (Sportster)	'97-'03	GYZ20HL	YTX20HL-BS	YTX20L-BS	-	
	GFR E-Starter	-	-	-	-	YB9-B*		XLH (Sportster)	'86-'96	GYZ20H	YTX20H-BS <sup>C</sup>	YTX20L-BS <sup>C</sup>	YB16-B-CX	
	KK, KZ Kick-Start	-	-	-	-	12N5.5-3B	750	Street	'14-'19	GYZ16HL	-	YTX14L-BS	-	
	KK, KZ E-Starter	-	-	-	-	YB9-B*	500	MT500 (Military)	All Years	-	YTX14AHL-BS	-	SYB14L-A2*	
	MX1, MXR Kick-Start	-	-	-	-	12N5.5-3B		Street	'14-'19	GYZ16HL	-	YTX14L-BS	-	
	MX1, MXR E-Starter	-	-	-	-	YB9-B*	350	SS350	All Years	-	-	-	6N11A-1B	
	Nebraska Kick-Start	-	-	-	-	12N5.5-3B	250	SS250, SX250	'75-'78	-	-	-	YB7L-B*	
	Nebraska E-Starter	-	-	-	-	YB9-B*	175	SS175, SX175	'74-'78	-	-	-	YB7L-B*	
	R1, R1S Kick-Start	-	-	-	-	12N5.5-3B	125	SS125, SX125	'74-'78	-	-	-	YB7L-B*	
	R1, R1S E-Starter	-	-	-	-	YB9-B*		SXT125	'75-'78	-	-	-	YB7L-B*	
	RC Rally	-	-	-	-	YB10L-B		TX125	'73-'78	-	-	-	YB7L-B*	
	RTX, RV, RX Kick-Start	-	-	-	-	12N5.5-3B	90	Z90	'73-'76	-	-	-	YB7L-B*	
	RTX, RV, RX E-Starter	-	-	-	-	YB9-B*	<b>HONDA</b>						-	-
	SPO1, SPO2 Kick-Start	-	-	-	-	12N5.5-3B	1800	GL1800 Gold Wing, F6B, F6C	'12-'19	GYZ20L	YTX20HL <sup>FA</sup>	YTX20L <sup>FA</sup>	-	
	SPO1, SPO2 E-Starter	-	-	-	-	YB9-B*		GL1800 Gold Wing	'01-'10	GYZ20L	YTX20HL <sup>FA</sup>	YTX20L <sup>FA</sup>	-	
	TOP Rally Kick-Start	-	-	-	-	12N5.5-3B		VTX1800C, F, N, R, Retro, S	'02-'11	GYZ20HL	YTX20HL-BS	YTX20L-BS	-	
	TOP Rally E-Starter	-	-	-	-	YB9-B*		NRX1800 Valkyrie Rune	'04-'05	GYZ20L	YTX20HL <sup>FA</sup>	YTX20L <sup>FA</sup>	-	
	Typhoon	-	-	-	-	YB7-A	1500	GL1500 Gold Wing	'88-'00	-	YTX24HL-BS	-	Y50-N18L-A3	
	XR1, XR2 Kick-Start	-	-	-	-	12N5.5-3B		GL1500 Valkyrie	'97-'03	GYZ16H	YTX14H-BS	YTX14L-BS	-	
	XR1, XR2 E-Starter	-	-	-	-	YB9-B*	1300	CTX1300	'14	-	YTX14S	-	-	
50	Bullit, Easy Moving, Runner	'97	-	-	-	YB4L-B		ST1300, A, P	'03-'12	-	YTX14S	-	-	
	Eaglet	'95-'97	-	-	-	YB4L-B		VTX1300C, R, S, Retro	'03-'12	GYZ16H	YTX14H-BS	YTX14L-BS	-	
	GSA E-Starter	-	-	-	-	YB4L-B		VT1300CS, CR, CT, CXA FURY	'09-'18	-	YTX14S	-	-	
	Runner	'97	-	-	-	YB4L-B	1200	GL1200 Gold Wing	'84-'87	-	YTX24HL-BS *	-	Y50-N18L-A-CX	
	Sloux E-Starter	-	-	-	-	YB4L-B		VFR1200F	'10-'14	-	YTX14S	-	-	
	Stalker, Storm, Top Rally	-	-	-	-	YB4L-B		VFR1200XD	'13	-	YTX14S	-	-	
	Typhoon	'97	-	-	-	YB4L-B		VFR1200X	'16-'17	-	YTX14S	-	-	

CC (CI)	<b>HARLEY-DAVIDSON</b>					
1870	CVO FLH Series	'17-'19	GYZ32HL	YX30L-BS	-	YB30L-B
(114)	FX, FL (Softail)	'18-'19	GYZ20HL	YTX20HL-BS	YTX20L-BS	-
1803	CVO FLH (Touring)	'07-'16	GYZ32HL	YX30L-BS	-	YB30L-B
(110)	CVO FXD (Dyna)	'07-'15	GYZ20HL	YTX20HL-BS	YTX20L-BS	-
	CVO FLST (Softail)	'07-'15	GYZ20HL	YTX20HL-BS	YTX20L-BS	-
	FLS (Softail Slim S, Fat Boy S)	'16-'17	GYZ20HL	YTX20HL-BS	YTX20L-BS	-
1750	FLH, FLT Series (Touring), FLR	'17-'19	GYZ32HL	YX30L-BS	-	YB30L-B
(107)	FX, FL (Softail)	'18-'19	GYZ20HL	YTX20HL-BS	YTX20L-BS	-
1690	FLH, FLT (Touring), FLR	'11-'16	GYZ32HL	YX30L-BS	-	YB30L-B
(103)	FXD (Dyna)	'12-'17	GYZ20HL	YTX20HL-BS	YTX20L-BS	-
	FLS (Softail)	'12-'17	GYZ20HL	YTX20HL-BS	YTX20L-BS	-
1584	FXD Series (Dyna)	'07-'11	GYZ20HL	YTX20HL-BS	YTX20L-BS	-
(96)	FXST, FLST Series (Softail)	'07-'11	GYZ20HL	YTX20HL-BS	YTX20L-BS	-
	FL, FLH Series (Touring)	'07-'10	GYZ32HL	YX30L-BS	-	YB30L-B
1450	FXD Series (Dyna)	'99-'06	GYZ20HL	YTX20HL-BS	YTX20L-BS	-

1100	CB1100F Super Sport	'83	-	YTX14AHL-BS	-	SYB14L-A2†
	CB1100	'10-'14	-	YTX14S	-	-
	CB1100EX	'17-	-	YTX14S	-	-
	CBR1100XX	'01-'04	-	YTX12S	-	-
	CBR1100XX	'97-'00	-	YTX12-BS	-	-
	GL1100 Gold Wing	'80-'83	-	YTX24HL-BS *	-	Y50-N18L-A-CX
	ST1100, ABS-TCS, 1100A	'91-'02	GYZ16H	YTX14H-BS	YTX14L-BS	-
	VF1100C V65 Magna	'83-'86	GYZ20H	YTX20H-BS	YTX20L-BS	YB18-A
	VF1100S V65 Sabre	'84-'85	GYZ20HL	YTX20HL-BS	YTX20L-BS	-
	VT1100C2 Shadow Sabre	'00-'07	GYZ16H	YTX14H-BS	YTX14L-BS	-
	VT1100C, C3, T Shadow (Spirit, Aero, A. C. E. Tourer)	'01-'07	GYZ16H	YTX14H-BS	YTX14L-BS	-
	VT1100C, C3, T Shadow (Spirit, Aero, A. C. E. Tourer)	'98-'00	-	-	-	HYB16A-AB
	VT1100C Shadow Spirit	'85-'97	-	-	-	HYB16A-AB
	VT1100C2 Shadow A. C. E.	'95-'99	-	-	-	HYB16A-AB

\* See Battery Cross Reference Chart on page 17  
 FA Must use factory activated battery  
 † This battery includes a sensor

C YTX20 series batteries may be used as an optional upgrade, but some modification to the hold down may be necessary. See battery label for retrofit cautions.  
 ▪ Top and front terminal mounts only



CC	Model	Year	GYZ Series AGM	High Performance AGM	AGM	Yumicron / Conventional	CC	Model	Year	GYZ Series AGM	High Performance AGM	AGM	Yumicron / Conventional	
	XL250S	'78-'81	-	-	-	6N4-2A-4	50	C110, CA110	'59-'69	-	-	-	6N2-2A	
	XR250L	'91-'96	-	YZ5S-BS	YTX4L-BS	-		MB5	'82	-	-	-	YB2.5L-C	
230	CRF230L	'14	-	YZ28V	YTX7L-BS	-		NA50 Express II	'80-'81	-	-	-	6N4-2A-6	
	CRF230L_M	'08-'13	-	YZ7S	YTX5L-BS	-		NA50 Express II	'79	-	-	-	6N2-2A	
	CRF230F_L (-'07)	'03-'19	-	YZ7S	YTX5L-BS	-		NC50 Express	'80-'83	-	-	-	6N4-2A-6	
200	CB200_T	'74-'76	-	-	-	YB9-B*		NC50 Express	'78-'79	-	-	-	6N2-2A	
	CL200 Scrambler	'74	-	-	-	YB9-B*		NC50 Express	'77	-	-	-	6N2A-2C-3	
	CM200T Twinstar	'81-'82	-	-	-	YB9-B*		NS50F	'90	-	-	-	YB3L-A	
	CM200T Twinstar	'80	-	-	-	6N12A-2C		NU50 Urban Express	'82-'83	-	-	-	YB2.5L-C-1	
	TLR200 Reflex	'86-'87	-	YZ5S-BS	YTX4L-BS	-		NU50M Urban Express Deluxe	'82-'83	-	-	-	YB4L-B	
	TR200 Fat Cat	'87	-	-	YTX7A-BS	-		NX50M Express SR	'81-'82	-	-	-	YB4L-B	
	TR200 Fat Cat	'86	-	-	YTX9-BS	-		Z50A (K1)	'69-'70	-	-	-	6N2A-2C-1	
	XL200R	'83-'84	-	-	-	YB3L-A		ZB50	'88	-	YZ5S-BS	YTX4L-BS	-	
185	CM185T Twinstar	'78-'79	-	-	-	6N12A-2D	<b>HUSABERG</b>							
	XL185S	'79-'83	-	-	-	6N4-2A-4		All Electric Start Models	'13	-	YZ7S	YTX5L-BS	-	
175	CA175 Touring (CD175K3)	'69-'70	-	-	-	6N12A-2D		All Electric Start Models	'04-'12	-	YZ7S	YTX5L-BS	-	
	CB175 Super Sport	'69-'73	-	-	-	YB9-B*		All Electric Start Models	'97-'03	-	-	YTX9-BS	-	
	CL175 Scrambler	'68-'73	-	-	-	YB9-B*	<b>HUSQVARNA</b>							
	SL175 Motosport	'70-'72	-	-	-	12N5-4B		900	NUA900	'13	GYZ16H	YTX14H-BS	YTX14-BS	-
	XL175	'73-'78	-	-	-	6N6-3B		693	701 Enduro, Supermoto	'16-'19	-	YZ10S	-	-
160	CB160 Sport	'65-'69	-	-	-	YB9-B*			701 Vitpilen	'18-'19	-	-	YT12A-BS	-
	CL160 Scrambler	'66-'68	-	-	-	YB9-B*		580	TE610E, SM610S	'00-'01	GYZ16H	YTX14H-BS	YTX14-BS	-
150	CRF150F_R	'06-'17	-	YZ7S	YTX5L-BS	-		511	TE, TXC	'11	-	YZ7S	YTX5L-BS	-
125	C125A	'19	-	YZ5S-BS	-	-		510	TC, TXC, TE, SMR	'10	-	YZ7S	YTX5L-BS	-
	CB125S	'81-'82	-	-	-	6N6-3B-1		501	FE	'14-'16	-	YZ7S	YTX5L-BS	-
	CB125S	'73-'80	-	-	-	6N6-3B			FE	'17-'19	Not Available	-	-	-
	CL125S Scrambler	'73-'75	-	-	-	6N4C-1B		450	FC	'14-'15	-	YZ7S	YTX5L-BS	-
	CRF125F	'14-'20	-	YZ5S-BS	YTX4L-BS	-			FC, FX	'16-'19	Not Available	-	-	-
	CT125 Trail	'77	-	-	-	6N4C-1B			FE	'14-'16	-	YZ7S	YTX5L-BS	-
	MSX125 Grom	'14-'19	-	YZ5S-BS	YTX4L-BS	-			FE	'17-'19	Not Available	-	-	-
	MT125 Elsinore	'74-'76	-	-	-	6N6-3B			TC, TXC, TE, SMR	'10	-	YZ7S	YTX5L-BS	-
	NX125	'88-'90	-	YZ28V	YTX7L-BS	-		449	TE	'11	-	YZ7S	YTX5L-BS	-
	SL125 Motosport	'71-'73	-	-	-	6N6-3B		400	TE410E	'00-'01	GYZ16H	YTX14H-BS	YTX14-BS	-
	XL125	'74-'78	-	-	-	6N4C-1B			Svartpilen, Vitpilen	'18-'19	-	-	YT12A-BS	-
	XL125S	'79-'84	-	-	-	6N4-2A-4		350	FC	'14-'15	-	YZ7S	YTX5L-BS	-
	XL125S	'85	-	-	-	YB2.5L-C			FC	'16-'19	Not Available	-	-	-
	Z125M, MA	'19	-	YZ5S-BS	YTX4L-BS	-			FE	'14-'16	-	YZ7S	YTX5L-BS	-
110	CRF110F	'13-'16	-	YZ5S-BS	YTX4L-BS	-			FE	'17-'19	Not Available	-	-	-
	CT110 Trail	'86	-	-	-	6N4-2A-4		310	TC, TXC, TE, SMR	'10	-	YZ7S	YTX5L-BS	-
	CT110 Trail	'80-'84	-	-	-	6N4-2A-8		300	TE	'14-'16	-	YZ7S	YTX5L-BS	-
	C110	'09-'10	-	YZ7S	YTX5L-BS	-			TE	'17-'19	Not Available	-	-	-
100	CB100 Super Sport	'70-'72	-	-	-	6N6-3B			FE	'16-'20	Not Available	-	-	-
	CL100_S Scrambler	'70-'73	-	-	-	6N6-3B			FE	'14-'16	-	YZ7S	YTX5L-BS	-
	SL100 Motosport	'70-'73	-	-	-	6N6-3B		250	FC	'14-'15	-	YZ5S-BS	YTX4L-BS	-
	XL100	'77-'78	-	-	-	6N4C-1B			FC	'16-'20	Not Available	-	-	-
	XL100	'74-'76	-	-	-	6N6-3B			FE	'14-'16	-	YZ7S	YTX5L-BS	-
	XL100S	'83-'85	-	-	-	6N4-2A-4			TE	'02-'16	-	YZ7S	YTX5L-BS	-
	XL100S	'81-'82	-	-	-	6N4C-1B			FE, TE	'17-'19	Not Available	-	-	-
	XL100S	'79-'80	-	-	-	6N4-2A-4			TXC	'08-'12	-	YZ7S	YTX5L-BS	-
90	CA200 Honda 90 (C200 Touring 90)	'63-'66	-	-	-	6N6-1D	<b>HYOSUNG</b>							
	CL90_L 5HP Scrambler	'67-'70	-	-	-	6N5.5-1D		700	ST7	'10-'13	-	-	YT14B-BS	-
	CM91 Honda 90 (C90M)	'66-'69	-	-	-	6N6-1D		650	GT650, R, S	'09-'16	GYZ16H	YTX14H-BS	YTX14-BS	-
	CT200 Trail 90	'64-'66	-	-	-	6N5.5-1D			GV650, SE	'09-'13	-	-	YT14B-BS	-
	CT90 Trail	'66-'79	-	-	-	6N5.5-1D		250	GT250, R	'09-'16	GYZ16H	YTX14H-BS	YTX14-BS	-
	EZ90 Cub	'91-'96	-	YZ7S	YTX5L-BS	-			GV250	'09-'16	-	-	YTX9-BS	-
	S90 Super (CS90)	'64-'69	-	-	-	6N6-1B	<b>INDIAN</b>							
	SL90 Motosport	'69	-	-	-	6N5.5-1D		1819 (111)	Chief Classic, Chief Vintage, ChiefTan, Roadmaster	'14-'20	GYZ20H	YTX20HL-BS	YTX20L-BS	-
	ST90 Trail Sport	'73-'75	-	-	-	6N5.5-1D			Chief Dark Horse, Springfield	'16-'20	GYZ20H	YTX20HL-BS	YTX20L-BS	-
80	XL80S	'83-'85	-	-	-	6N4-2A-8		1720 (105)	Chief Classic, Vintage, Dark Horse	'12-'13	-	YTX24HL-BS	-	-
	XL80S	'80-'82	-	-	-	6N4C-1B			Chief (all models)	'09-'11	GYZ20H	YTX20H-BS	YTX20-BS	-
75	XL75	'77-'79	-	-	-	6N4C-1B		1638 (100)	Chief	'02-'03	-	YTX24HL-BS	-	-
70	C70 Passport	'82-'83	-	-	-	YB5L-B		1442 (88)	Scout, Spirit	'02-'03	GYZ20H	YTX20H-BS	YTX20-BS	-
	C70 Passport	'80-'81	-	-	-	6YB11-2D*		1203 (73)	FTR 100	'19	GYZ16H	YTX14H-BS	-	-
	C70M Honda	'70-'73	-	-	-	6YB11-2D*			All Models	'99-'01	GYZ20H	YTX20H-BS	YTX20-BS	-
	CL70 Scrambler	'69-'73	-	-	-	6N5.5-1D		1133 (69)	Scout, Bobber	'15-'20	-	YTX14AH	-	-
	CT70	'91-'94	-	YZ5S-BS	YTX4L-BS	-		999 (61)	Scout Sixty	'16-'20	-	YTX14AH	-	-
	CT70 Trail	'80-'82	-	-	-	6N4-2A-6								
	CT70 Trail	'74-'79	-	-	-	6N4C-1B								
	CT70 Trail, 70H	'69-'71	-	-	-	6N2A-2C								
	CT70, 70H	'72-'73	-	-	-	6N2A-2C-3								
	SL70 Motosport	'73	-	-	-	6N2A-2C-3								
	SL70 Motosport	'71-'72	-	-	-	6N2A-2C								
	XL70	'74-'76	-	-	-	6N4C-1B								
65	S65 Sport (CS65)	'65-'69	-	-	-	6N2-2A								
55	C, CA105T Trail	'62-'65	-	-	-	6N2-2A								

\* See Battery Cross Reference Chart on page 17

\* Top and front terminal mounts only





# MOTORCYCLE APPLICATIONS

MOTORCYCLE

CC	Model	Year	GYZ Series AGM	High Performance AGM	AGM	Yumicron / Conventional	CC	Model	Year	GYZ Series AGM	High Performance AGM	AGM	Yumicron / Conventional
	Versys-X 300, ABS	'17-'19	-	-	YTX9-BS	-	525	EXC Racing	'03-'07	-	YTZ5S-BS	YTX4L-BS	-
	KLX300R	'20	-	YTZ7S	-	-		MX Desert Racing	'03	-	YTZ7S	YTX5L-BS	-
250	EX250, Ninja 250R	'08	-	-	YTX7A-BS	-		MXC Racing	'00	-	YTZ7S	YTX5L-BS	-
	EX250, Ninja 250R	'09-'12	-	-	YTX9-BS	-	520	E/XC, M/XC Racing 4-Stroke	'00-'02	-	YTZ5S-BS	YTX4L-BS	-
	A1 Series	'66-'71	-	-	-	YB9-B*		E/XC, M/XC Racing 4-Stroke (Opt)	'00-'02	-	YTZ7S	YTX5L-BS	-
	EL250, HS	'88-'93	-	-	-	YB9L-A2	450	EXC Racing	'03-'05	-	YTZ5S-BS	YTX4L-BS	-
	EX250 Ninja	'95-'07	-	YTZ8V	YTX7L-BS	-		EXC Racing	'05-'13	-	YTZ7S	YTX5L-BS	-
	EX250 Ninja	'86-'94	-	-	-	YB9L-A2		SX-F, XC-F, XC-W	'08-'10	-	YTZ7S	YTX5L-BS	-
	F4 Series	'69-'70	-	-	-	12N5.5-4A		SX-F	'11-'15	-	YTZ5S-BS	YTX4L-BS	-
	F8 Series	'71-'72	-	-	-	6N2-2A-3		450SMR	'09-'12	-	YTZ7S	YTX5L-BS	-
	F11 Series	'73-'75	-	-	-	6N4B-2A-3		450SMR	'13	-	YTZ5S-BS	YTX4L-BS	-
	KE250-B	'77-'79	-	-	-	6N6-1D-2	400	EXC, Racing	'05-'11	-	YTZ7S	YTX5L-BS	-
	KH250-A	'76	-	-	-	12N5.5-4A		EXC, Racing	'03-'05	-	YTZ5S-BS	YTX4L-BS	-
	KL250 Super Sherpa	'00-'10	-	YTZ8V	YTX7L-BS	-		XC-W	'09-'10	-	YTZ7S	YTX5L-BS	-
	KL250	'78-'84	-	-	-	6N6-1D-2		E/XC Racing 4-Stroke	'00-'02	-	YTZ5S-BS	YTX4L-BS	-
	KL250-D KLR	'85-'05	-	-	-	YB4L-A		E/XC Racing 4-Stroke (Opt)	'00-'02	-	YTZ7S	YTX5L-BS	-
	KLX250S, SF, Camo	'06-'20	-	YTZ8V	YTX7L-BS	-		LC4 E/XC	'96-'98	-	-	YTX9-BS	-
	KZ250 CSR, LTD	'80-'83	-	-	-	YB10L-A2*		RXC LC4	'96-'01	-	-	YTX9-BS	-
	S1 Series	'73-'75	-	-	-	12N5.5-4A	390	Duke	'15-'18	-	-	YTX9-BS	-
230	KLX230, ABS	'20	-	-	YTX7A-BS	-		RC 390	'18	-	-	YTX9-BS	-
	KLX230R	'20	-	-	YTX5L-BS	-	350	XC-F	'11-'12	-	YTZ7S	YTX5L-BS	-
200	KZ200-A	'78-'79	-	-	-	YB10L-B		SX-F	'11-'15	-	YTZ5S-BS	YTX4L-BS	-
175	F7 Series	'71-'75	-	-	-	6N4-2A-5		EXC-F	'14	-	YTZ5S-BS	YTX4L-BS	-
	KE175-B	'76-'78	-	-	-	6N6-1D-2		Freeride	'13	-	YTZ7S	YTX5L-BS	-
	W175 SE	'19	-	YTZ8V	YTX7L-BS	-	300	XC, XC-W, EXC-F	'11-'13	-	YTZ5S-BS	YTX4L-BS	-
140	KLX140, G, L	'08-'20	-	YTZ8V	YTX7L-BS	-		XC, XC-W	'14	-	YTZ7S	YTX5L-BS	-
125	BN125 Eliminator	'01-'10	-	-	-	YB9-B*	250	EXC, Racing	'05-'10	-	YTZ7S	YTX5L-BS	-
	F6 Series	'71-'73	-	-	-	6N4-2A-5		EXC, Racing	'03-'05	-	YTZ5S-BS	YTX4L-BS	-
	KE125-A	'76-'83	-	-	-	6N6-1D-2		EXF	'05-'10	-	YTZ7S	YTX5L-BS	-
	KS125 Series	'74-'75	-	-	-	6N6-1D-2		XC, EXC	'11-'12	-	YTZ5S-BS	YTX4L-BS	-
	Z125 PRO	'17-'19	-	YTZ5S-BS	YTX4L-BS	-		EXC-F	'11-'12	-	YTZ7S	-	-
120	C2SS RoadRunner	'67-'69	-	-	-	6N4-2A-3		SX-F, EXC, EXC-F	'12-'15	-	YTZ5S-BS	YTX4L-BS	-
	C2TR RoadRunner	'67-'69	-	-	-	6N4-2A-3		EXC-F, SX-F, XC	'16-'19	Not Available	-	-	-
110	KLX110, L	'03-'20	-	YTZ5S-BS	YTX4L-BS	-		XC-F	'07-'11	-	YTZ7S*	YTX5L-BS	-
100	G3SS Series	'75	-	-	-	6N4-2A-5		XC-W	'08-'13	-	YTZ5S-BS*	YTX4L-BS	-
	G3TR Series	'71	-	-	-	6N4-2A-3†		XC-W	'14	-	YTZ7S*	YTX5L-BS	-
	G4TR Series	'73-'75	-	-	-	6N4-2A-5		XC-W, XCF-W	'15-'17	-	YTZ5S-BS*	YTX4L-BS	-
	G4TR Series	'70-'72	-	-	-	6N2-2A-3		XC-W	'18-'19	Not Available	-	-	-
	G5 Series	'74-'75	-	-	-	6N4-2A-5		XCF-W	'06-'11	-	YTZ7S*	YTX5L-BS	-
	G5 Series	'72-'73	-	-	-	6N4-2A-3	200	Duke	'13	-	-	YTX9-BS	-
	KE100-A	'79-'81	-	-	-	6N6-1D-2		200 XC-W	'14	-	YTZ7S	YTX5L-BS	-
	KE100-A	'76-'78	-	-	-	6N4-2A-5		200 XC-W	'13, '15-'16	-	YTZ5S-BS	YTX4L-BS	-
	KE100-B	'82-'01	-	-	-	6N6-1D-2	125	Duke	'13	-	YTZ8V	YTX7L-BS	-
	KH100-B	'76-'77	-	-	-	6N4-2A-5							
	KM100-A	'79-'81	-	-	-	6N6-1D-2							
	KM100-A	'76-'78	-	-	-	6N4-2A-5							
	KV100-A	'76	-	-	-	6N4-2A-5							
90	G3SS Series	'73-'74	-	-	-	6N4-2A-5							
	G3SS Series	'69-'72	-	-	-	6N4-2A-3†							
	G3TR Series	'69-'70	-	-	-	6N4-2A-3†							
	MC1 Series	'73-'75	-	-	-	6N4-2A-5							

## KTM

1290	Super Duke, R	'14-'19	GYZ16H	YTX14H-BS	YTX14-BS	-
	Super Duke GT	'17-'19	-	YTZ14S	-	-
	Super Adventure	'14-'19	-	YTZ14S	-	-
1190	RC8	'09-'16	-	YTZ14S	-	-
	Adventure	'13-'16	-	YTZ14S	-	-
1090	Adventure	'17-'19	-	YTZ14S	-	-
990	Super Duke	'03-'13	-	YTZ14S	-	-
	Supermoto, SM R	'09-'13	-	YTZ14S	-	-
	Adventure	'03-'13	-	YTZ14S	-	-
950	Superenduro	'09-'11	-	YTZ14S	-	-
690	Duke	'08-'12	-	YTZ10S	-	-
	Duke	'13-'17	-	-	YTX9-BS	-
	Supermoto, SM R	'07-'13	-	YTZ10S	-	-
	Enduro R	'08-'18	-	YTZ10S	-	-
640	Adventure, Duke, RXC LC4 Super Moto	'99-'02	-	-	YTX9-BS	-
	Duke II, LC4, Adventure	'03-'08	-	YTZ10S	-	-
625	SMC, SXC	'03-'09	-	YTZ10S	-	-
620	Adventure, Duke, LC4	'96-'98	-	-	YTX9-BS	-
530	EXC, Racing	'03-'05	-	YTZ5S-BS	YTX4L-BS	-
	EXC, Racing	'05-'12	-	YTZ7S	YTX5L-BS	-
	XC-W	'09-'12	-	YTZ7S	YTX5L-BS	-

\* See Battery Cross Reference Chart on page 17

†† G3SS and G3TR models having the engine production #235611 and above, use a 6N4-2A-5 battery

## KYMCO

250	Venox250	'09-'10	-	-	YTX9-BS	-
-----	----------	---------	---	---	---------	---

## MOTO GUZZI

1400	AJDACE	'16-'18	GYZ20H	YTX20H-BS	YTX20-BS	-
1380	California	'13-'17	GYZ20H	YTX20H-BS	YTX20-BS	-
	Eldorado	'16	-	YTX20CH-BS	-	-
	MGX-21 Flying Fortress	'16	GYZ20H	YTX20H-BS	YTX20-BS	-
1200	Norge	'09-'16	-	YTX20CH-BS	-	-
	Sport, ABS	'09-'10	-	YTX20CH-BS	-	-
	Breva 1200	'09-'10	-	YTX20CH-BS	-	-
	Stelvio	'08-'17	-	YTX20CH <sup>FA</sup>	-	-
	1200 Sport	'09-'13	-	YTX20CH-BS	-	-
	GRISO V8	'09-'17	-	YTX20CH-BS	-	-
1100	1100 California	'03-'05	-	-	YTX15L-BS	-
	California, Special, Jackal, Breva, Griso	'05-'13	-	YTX20CH-BS	YTX16-BS	-
	Stone, EV	'94-'05	GYZ32HL	YX30L-BS	-	53030
	Quota 1100 ES	'99-'02	-	-	YTX15L <sup>FA</sup>	-
	Sport 1100i	'97-'99	-	-	YTX15L-BS	-
	V11 Bassa	'99-'00	GYZ32HL	YX30L-BS	-	53030
	V11 EV	'98-'99	GYZ32HL	YX30L-BS	-	53030
	V11 Le Mans, Sport	'99-'05	-	-	YTX15L <sup>FA</sup>	-
1064	California Classic, Vintage	'12	GYZ20HL	YTX20HL-BS	YTX20L-BS	-
1000	California III	'89-'93	GYZ32HL	YX30L-BS	-	53030
	Convert		GYZ32HL	YX30L-BS	-	53030
	Daytona		GYZ32HL	YX30L-BS	-	53030
	Le Mans		GYZ32HL	YX30L-BS	-	53030
	Mille		GYZ32HL	YX30L-BS	-	53030
	1000NT		GYZ32HL	YX30L-BS	-	53030
	Quota		GYZ32HL	YX30L-BS	-	53030

<sup>FA</sup> Must use factory activated battery

CC	Model	Year	GYZ Series AGM	High Performance AGM	AGM	Yumicron / Conventional	CC	Model	Year	GYZ Series AGM	High Performance AGM	AGM	Yumicron / Conventional
	V10 Centauro Sport, GT	'99-End	-	-	YTX15L* <sup>‡</sup>	-		Zip - Zip (Fast Rider)		-	-	-	YB4L-B
936	Bellagio	'10	GYZ20HL	YTX20HL-BS	YTX20L-BS	-							
853	V9 Bobber, Roamer	'16-'17	GYZ16H	YTX14H-BS	YTX14-BS	-							
850	Le Man		GYZ32HL	YX30L-BS	-	53030							
	T3, T4, T5		GYZ32HL	YX30L-BS	-	53030							
750	Breva 750	'04-'10	-	YTX14AHL-BS	-	-							
	V7 Classic	'08-'12	-	YTX14AHL-BS	-	-							
	Nevada		GYZ20HL	YTX20HL-BS	YTX20L-BS	YB18L-A							
	Nevada 750 Classic	'10	-	YTX14AHL-BS	-	-							
	NTX		GYZ20HL	YTX20HL-BS	YTX20L-BS	YB18L-A							
	Strada		GYZ20HL	YTX20HL-BS	YTX20L-BS	YB18L-A							
	V7		GYZ32HL	YX30L-BS	-	53030							
	V7, Racer, Scrambler, Stone, Special	'13-'17	GYZ16H	YTX14H-BS	YTX14-BS	-							
	V7 Racer	'11-'12	-	YTX14AHL-BS	-	-							
	V7 III Carbon Shine, Dark, Milano, Rough	'18	GYZ16H	YTX14H-BS	YTX14-BS	-							
	V75		GYZ20HL	YTX20HL-BS	YTX20L-BS	YB18L-A							
650	NTX		GYZ20HL	YTX20HL-BS	YTX20L-BS	YB18L-A							
	V65		GYZ32HL	YX30L-BS	-	53030							
	V65 Florida		GYZ20HL	YTX20HL-BS	YTX20L-BS	YB18L-A							
500	Falcone		-	-	-	B38-6A							
	Falcone u.t.		GYZ20HL	YTX20HL-BS	YTX20L-BS	YB18L-A							
	V50		GYZ32HL	YX30L-BS	-	53030							
<b>MuZ</b>							<b>POLARIS-SLINGSHOT</b>						
660	Skorpion '95-'01	'95-'01	-	-	-	YB9L-A2	ALL All Models			GYZ32HL	YX30L-BS	-	YB30L-B
125	All Models All Years	ALL	-	-	-	YB9L-A2	<b>PUCH</b>						
<b>MV AGUSTA</b>							<b>ROYAL ENFIELD</b>						
1000	F4	'05-'16	-	YTZ10S	-	-	650	Int 650, Continental GT 650	'19-'20	GYZ16H	YTX14H-BS	YTX14-BS	-
	Brutale 1078RR, 1090	'09-'16	-	YTZ10S	-	-	535	Continental GT 535	'14-'17	-	YTX14AHL-BS	-	-
910	Brutale	'06-'09	-	YTZ10S	-	-	500	Classic 500, Bullet 500	'09-'20	-	YTX14AHL-BS	-	-
800	Brutale	'16	-	YTZ10S	-	-		All Kick-start Models	'95-'99	-	-	-	YB7-A*
750	F4, Brutale	'00-'08	-	YTZ10S	-	-		All Kick-start Models	'00-'03	-	-	-	YB5L-B*
675	F3, Brutale	'16	-	YTZ10S	-	-		All Electric Start Models	'00-'03	-	YTX14AHL-BS	-	SYB14L-A2 †
							411	Himalayan	'17-'20	-	-	YTX9-BS	-
							350	All Kick-start Models	'95-'99	-	-	-	YB7-A*
								All Kick-start Models	'00-'03	-	-	-	YB5L-B*
								All Electric Start Models	'00-'03	-	YTX14AHL-BS	-	SYB14L-A2 †
							<b>SUZUKI</b>						
							1800	VZR1800 (M109R)	'06-'17	-	YTX20CH-BS	YTX16-BS	-
								VLR1800 (C109R)	'08-'12	-	YTX20CH-BS	YTX16-BS	-
							1600	Marauder, Boulevard M95	'04-'05	-	YTX20CH-BS	YTX16-BS	-
							1500	VL1500 Intruder, Boulevard C90	'98-'11	-	-	YTX16-BS-1	-
								VL1500 Boulevard C90	'14-'17	-	YTX20CH-BS	YTX16-BS	-
								VZ1500 Boulevard M90	'09-'17	-	YTX20CH-BS	YTX16-BS	-
							1400	GV1400G, D, T Cavalcade	'86-'88	-	YTX24HL-BS †	-	SY50-N18L-AT
								VZ1400GL Intruder, GLP, S83	'87-'11	-	-	YTX16-BS-1	-
							1300	GSX1300BK B-King	'08-'11	-	-	YTX12-BS	-
								GSX1300R Hayabusa	'99-'07	-	-	YTX12A-BS	-
								GSX1300R, Z Hayabusa	'08-'18	-	-	YTX12-BS	-
							1250	GSF1250S, A Bandit, FA	'07-'16	-	-	YT12A-BS	-
							1200	GSF1200, S Bandit	'97-'05	-	-	YTX12-BS	-
								GV1200GL Madura	'85-'86	-	YTX14AHL-BS	-	YB14L-B2
							1150	GS1150E, S	'83-'86	-	YTX14AHL-BS	-	YB14L-B2
							1100	GSX1100S Katana	'81-'01	-	YTX14AHL-BS	-	SYB14L-A2 †
								GS1100E, S	'80-'83	-	YTX14AHL-BS	-	SYB14L-A2 †
								GS1100G, K, L, Katana	'82-'84	-	YTX14AHL-BS	-	SYB14L-A2 †
								GSX-R1100	'86-'92	-	YTX14AHL-BS	-	SYB14L-A2 †
								GSX-R1100 W	'93-'98	-	-	YTX12-BS	-
								GSX1100F Katana	'88-'93	-	YTX14AHL-BS	-	YB14L-B2
								GSX1100G	'91-'93	GYZ16H	YTX14H-BS	YTX14-BS	-
							1000	DL1000V-Strom, Adventure	'02-'16	GYZ16H	YTX14H-BS	YTX14-BS	-
								DL1000AL8, AL9	'18-'19	-	YTZ14S	-	-
								GS1000	'78-'82	-	YTX14AHL-BS	-	SYB14L-A2 †
								GSX-R1000, Z	'01-'04	-	-	YTX12-BS	-
								GSX-R1000, A	'05-'16	-	-	YT12A-BS	-
								GSX-R1000R, Z, AL8	'17-'18	-	YTZ10S	-	-
								GSX-S1000, A, F, FA	'16-'17	-	-	YT12A-BS	-
								GSX-S1000, A, F, FA	'18	-	YTZ10S	-	-
								SV1000, S	'03-'07	GYZ16H	YTX14H-BS	YTX14-BS	-
								TL1000R	'98-'03	-	-	YT12A-BS	-
								TL1000S	'97-'01	-	-	YTX12-BS	-
							900	RF900, R, S, ZS	'94-'97	-	-	YTX9-BS	-
							850	GS850G, GL	'79-'83	-	YTX14AHL-BS	-	SYB14L-A2 †
							800	VL800 Intruder Volusia, Boulevard C50, T, M50	'01-'17	-	-	YTX12-BS	-
								VS800 GL, S Intruder, Boulevard S50	'92-'12	-	-	YB16B-A1*	
								VX800	'90-'93	-	-	YB16B-A	
								VZ800 Marauder	'97-'08	-	YTX12-BS	-	
							750	GS750, Katana	'77-'83	-	YTX14AHL-BS	-	SYB14L-A2 †
								GSX750F Katana	'98-'06	-	-	YTX9-BS	-
								GSX750F Katana	'89-'97	-	YTX14AHL-BS	-	YB14L-B2
								GSX-R750	'00-'19	-	-	YT12A-BS	-
								GSX-R750	'96-'99	-	-	YTX9-BS	-
								GSX-R750	'86-'92	-	YTX14AHL-BS	-	SYB14L-A2 †
								GSXR750W	'94-'95	-	-	YTX9-BS	-
								GSXR750W	'93	-	-	YTX12-BS	-
								GSX-S750	'15-'19	-	-	YT12A-BS	-
								GT750 LeMans	'72-'77	-	YTX14AHL-BS	-	SYB14L-A2 †

\* See Battery Cross Reference Chart on page 17  
 † Includes terminal adaptor for converting to side mount  
 (x2) Order two batteries

‡ This battery includes a sensor  
 † Top and front terminal mounts only and eliminates need for sensor (needs to be disabled)  
 FA Must use factory activated battery



CC	Model	Year	GYZ Series AGM	High Performance AGM	AGM	Yumicron / Conventional	CC	Model	Year	GYZ Series AGM	High Performance AGM	AGM	Yumicron / Conventional
700	VS750GLP Intruder	'88-'91	-	-	-	YB16B-A1*	RV200 (VanVan200)	'17-'19	-	YTZ8V	-	-	-
	GS700E, GS700ES	'85	-	YTX14AHL-BS	-	SYB14L-A2†	GT185 Adventurer	'73-'77	-	-	-	-	YB10L-A2
	GV700GL Madura	'85	-	YTX14AHL-BS	-	YB14L-B2	TC185 Ranger	'74-'77	-	-	-	-	YB10L-A2
	VS700GL Intruder	'85-'87	-	-	-	YB16B-A1*	TS185 Sierra	'77-'81	-	-	-	-	6N4B-2A
650	DL650 V-Strom ABS, Adventure	'04-'19	-	-	YTX12-BS	-	TS185 Sierra	'71-'76	-	-	-	-	6N4-2A
	DR650S ER, ES	'94-'95	-	-	YTX12-BS	-	DR125, SE, SES	'94-'96	-	YTZ8V	YTX7L-BS	-	-
	DR650S N, P	'92-'93	-	-	YTX4L-BS	-	GN125, E	'91-'96	-	-	-	-	YB7-A*
	DR650S	'90-'91	-	-	-	YB5L-B*	GN125, E	'82-'83	-	-	-	-	YB7-A*
	DR650SE	'98-'19	-	-	YTX9-BS	-	RV125 SE, R	'94	-	YTZ8V	YTX7L-BS	-	-
	DR650SE (CN)	'96-'97	-	-	YTX9-BS	-	RV125 Tracker	'73-'77	-	-	-	-	6N4-2A
	DR650SE	'96-'97	-	-	-	YB10L-B2	SP125	'86-'88	-	-	-	-	6N4-2A
	GR650 Tempter, X	'83	-	YTX14AHL-BS	-	SYB14L-A2†	SP125	'82-'83	-	-	-	-	6N4B-2A
	GS650E	'81-'82	-	-	-	YB10L-A2	TC125 Prospector	'73-'77	-	-	-	-	6N4B-2A
	GS650 (All)	'81-'83	-	YTX14AHL-BS	-	SYB14L-A2†	TS125 Duster	'71-'81	-	-	-	-	6N4B-2A
	GSX650F	'08-'11	-	-	YTX9-BS	-	B120P	-	-	-	-	-	6N4-2A
	LS650 Savage, S40	'86-'19	-	YTX14AHL-BS	-	YB14L-B2	TC120, TC120-II, TC120R	'71	-	-	-	-	6N4B-2A
	SV650	'99-'02	-	-	YT12A-BS	-	B105P	-	-	-	-	-	6N4-2A
	SV650A, SA	'03-'10	-	-	YT12A-BS	-	A100 Go-fer	'76-'77	-	-	-	-	6N4-2A
	SV650, S	'03-'13	-	-	YTX12-BS	-	A100 Go-fer	'69	-	-	-	-	6N4-2A
	SV650	'17	-	-	YT12A-BS	-	B100P	-	-	-	-	-	6N4-2A
	SPV650 Gladius	'09-'15	-	-	YT12A-BS	-	SP100	'83	-	-	-	-	6N4B-2A
	XN85 Turbo	'83	-	YTX14AHL-BS	-	SYB14L-A2†	Scrambler AC100	'69	-	-	-	-	6N4-2A
600	GSF600S Bandit	'96-'03	-	-	YTX9-BS	-	Sport AS100	'69	-	-	-	-	6N4-2A
	GSX-R600	'97-'19	-	-	YTX9-BS	-	TC100 Blazer	'73-'77	-	-	-	-	6N4-2A
	GSX-R600W	'92-'93	-	-	YTX9-BS	-	TS100 Honcho	'78-'81	-	-	-	-	6N4B-2A
	GSX600F Katana	'98-'06	-	-	YTX9-BS	-	TS100 Honcho	'73-'77	-	-	-	-	6N4-2A
	GSX600F Katana	'88-'97	-	-	-	YB10L-B2	RV90 Rover	'73-'77	-	-	-	-	6N4B-2A
	SP600	'85	-	-	-	YB5L-B*	RV90 Rover	'72	-	-	-	-	6N2-2A-4
	RF600R, S	'94-'96	-	-	YTX9-BS	-	TC90	-	-	-	-	-	6N4-2A
550	GS550E, L, M, TX	'77-'82	-	-	-	YB10L-A2	TC90J, TC90R	-	-	-	-	-	6N2-2A-4
	GS550E, ES, L	'83-'86	-	-	-	YB10L-B	Model K10, Model K10P	'68	-	-	-	-	6N4-2A
	GT550 Indy	'72-'77	-	-	-	YB9L-A2	Sport 80 (Models K11 & K11P)	'68	-	-	-	-	6N4-2A
500	GS500, F	'01-'11	-	-	-	YB10L-B2	Trail 80 (Models K15 & K15P)	'68	-	-	-	-	6N4-2A
	GS500E	'89-'00	-	-	-	YB10L-B2	TS75 Colt	'75-'77	-	-	-	-	6N4-2A
	GT500 Titan	'76-'77	-	-	-	YB7-A*	DR-Z70	'08-'09	-	-	YT4B-BS	-	-
	SP500	'81-'83	-	-	-	6N4B-2A	DR-Z70	'15-'17	-	-	YT4B-BS	-	-
	T500 Titan	'68-'75	-	-	-	YB7-A*	Model 31	'68	-	-	-	-	6N2-2A-4
450	GS450	'83-'88	-	-	-	YB12B-B2	AC50, AS50	'71	-	-	-	-	6N4-2A
	GS450	'80-'82	-	-	-	YB10L-A2	DR-Z50	'19	-	-	YT4B-BS	-	-
425	GS425, GS425E, L	'79	-	-	-	YB10L-A2	OR50	'79-'80	-	-	-	-	6N4B-2A
400	DR-Z400, E, S, SM	'00-'19	-	-	YT7B-BS	-	Sport 50 (Model M12)	'68	-	-	-	-	6N4-2A
	GN400T, X	'80-'82	-	-	-	6N4B-2A	TS50	'74	-	-	-	-	6N4-2A
	GS400	'77-'78	-	-	-	YB10L-A2							
	GS400X	'77-'78	-	-	-	YB7-A*							
	GSF400 Bandit	'91-'93	-	-	YTX9-BS	-							
	SP400	'80	-	-	-	6N4B-2A							
	TS400 Apache	'76-'77	-	-	-	6N4B-2A							
	TS400 Apache	'72-'75	-	-	-	YB5L-B*							
380	GT380 Sebring	'72-'77	-	-	-	YB7-A*							
370	SP370	'78-'79	-	-	-	6N4B-2A							
350	DR350S	'90-'96	-	YTZ5S-BS	YTX4L-BS	-							
	DR350SE	'94-'99	-	YTZ8V	YTX7L-BS	-							
	T350 Series	'79	-	-	-	YB5L-B*							
305	Scrambler TC305	'69	-	-	-	YB5L-B*							
	T305	'69	-	-	-	YB5L-B*							
300	GS300L	'82-'85	-	-	-	YB12B-B2							
250	DR250S	'90-'92	-	YTZ5S-BS	YTX4L-BS	-							
	DR250S EP, ER, ES	'93-'95	-	YTZ8V	YTX7L-BS	-							
	DR-Z250	'01-'07	-	YTZ7S	YTX5L-BS	-							
	GN250	'82-'88	-	-	-	YB10L-A2							
	GS250T	'80-'81	-	-	-	YB10L-A2							
	GSX250R(LB, RL9)	'18-'19	-	-	YTX9-BS	-							
	GT250 Hustler	'73-'77	-	-	-	YB5L-B*							
	GW250	'13-'17	-	-	YTX9-BS	-							
	GZ250	'99-'12	-	YTZ8V	YTX7L-BS	-							
	Model T20	'69	-	-	-	YB5L-B*							
	SP250	'82-'85	-	-	-	6N4B-2A							
	Scrambler TC250	'69	-	-	-	YB5L-B*							
	T250, T250-II, T250J, T250R	'72	-	-	-	YB5L-B*							
	TS250 Savage	'73-'81	-	-	-	6N4B-2A							
	TS250 Savage	'69-'72	-	-	-	6N2-2A-4							
	TU250X	'09-'17	-	YTZ8V	YTX7L-BS	-							
200	DR200SE	'96-'13	-	YTZ8V	YTX7L-BS	-							
	DR200S	'15-'19	-	YTZ8V	YTX7L-BS	-							
	SP200	'86-'88	-	-	-	YB4L-B							
	T200, TC200	-	-	-	-	YB5L-B*							

## TRIUMPH

2300	Rocket III	'03-'18	GVZ20HL	YTX20HL-BS	YTX20L-BS	-
1600	Thunderbird	'09-'18	GVZ20HL	YTX20HL-BS	YTX20L-BS	-
1215	Tiger Explorer	'12-'18	GVZ20HL	YTX20HL-BS	YTX20L-BS	-
	Trophy	'12-'17	GVZ20HL	YTX20HL-BS	YTX20L-BS	-
1200	Trophy	'00-'04	GVZ16H	YTX14H-BS	YTX14L-BS	-
	All Other Models	'91-'99	-	YTX14AHL-BS	-	YB14L-A2
	Bonneville	'17	-	-	YTX9-BS	-
1050	Speed Triple, R	'05-'10	-	-	YTX12-BS	-
	Speed Triple, R	'11-'18	GVZ16H	YTX14H-BS	YTX14L-BS	-
	Sprint ST	'05-'10	-	-	YTX12-BS	-
	Sprint GT	'11-'18	GVZ16H	YTX14H-BS	YTX14L-BS	-
	Tiger	'07-'12	-	-	YT12B-BS	-
	Tiger	'13-'18	GVZ16H	YTX14H-BS	YTX14L-BS	-
1000	Daytona	'92-'93	-	YTX14AHL-BS	-	-
955	Daytona 955i, Speed Triple, Sprint ST	'99-'04	GVZ16H	YTX14H-BS	YTX14L-BS	-
	Sprint RS	'00-'04	GVZ16H	YTX14H-BS	YTX14L-BS	-
	Tiger	'01-'07	GVZ16H	YTX14H-BS	YTX14L-BS	-
	All Other Models	'96-'97	-	YTX14AHL-BS	-	-
900	Scrambler, Bonneville	'06-'07	-	-	YTX12-BS	-
	T90	-	-	-	-	6N11A-1B
	Tiger	'99-'01	GVZ16H	YTX14H-BS	YTX14L-BS	-
	Thunderbird	'02-'03	-	YTX14AHL-BS	-	-
	All Other Models	'91-'01	-	YTX14AHL-BS	-	-
865	America	'01-'13	-	-	YT12B-BS	-
	Bonneville T100, SE	'05-'07	-	-	YTX12-BS	-
	Scrambler	'05-'07	-	-	YTX12-BS	-
	Bonneville T100, SE, FI	'08-'10	-	-	YT12B-BS	-
	Scrambler	'08-'10	-	-	YT12B-BS	-
	Bonneville T100, SE, FI	'11-'18	-	-	YTX12-BS	-
	Scrambler	'11-'16	-	-	YTX12-BS	-
	Speedmaster	'03-'15	-	-	YTX12-BS	-

\* See Battery Cross Reference Chart on page 17  
 † Includes terminal adaptor for converting to side mount

† This battery includes a sensor

# MOTORCYCLE APPLICATIONS

MOTORCYCLE

CC	Model	Year	GYZ Series AGM	High Performance AGM	AGM	Yumicron / Conventional	CC	Model	Year	GYZ Series AGM	High Performance AGM	AGM	Yumicron / Conventional
800	Thruxton	'03-'16	-	-	YTX12-BS	-	750	FZ-10	'17	-	YTZ10S	-	-
	Bonneville	'01-'05	-	-	YTX12-BS	-	950	XV95CT,V.V Star 950,Tourer	'09-'17	-	YTZ14S	-	-
	Speedmaster	'03-'05	-	-	YTX12-BS	-		XV95CC Copycat	'09-'16	-	YTZ14S	-	-
	Tiger 800	'11-'17	-	-	YTX16-BS	-		Bolt, Bolt R-SPEC	'14-'20	-	YTZ14S	-	-
750	Bonneville, Tiger		-	-	-	YB9-B*		SC950	'17	-	YTZ14S	-	-
	T150 Trident		-	-	-	YB7L-B*	920	XV920 Virago	'82	-	YTX24HL-BS	-	SY50-N18L-AT
	All Other Models	'93-'97	-	YTX14AHL-BS	-	-		XV920M Midnight Virago	'83	-	YTX24HL-BS	-	Y50-N18L-A-CX
675	Daytona 675, R	'06-'10	-	-	YT7B-BS	-		XV920R Virago	'81-'83	-	YTX24HL-BS	-	Y50-N18L-A-CX
	Daytona 675, R	'11-'16	-	-	YTX9-BS	-	900	XJ900R Seca	'83	-	YTX14AHL-BS	-	SYB14L-A2†
	Street Triple, R	'08-'17	-	-	YTX9-BS	-		XSR900	'16-'18	-	YTZ10S	-	-
650	T120 Bonneville		-	-	-	YB7L-B*		MT09	'18	-	YTZ10S	-	-
600	600 (12V)		Not available	-	-	-	850	TDM850	'92-'93	-	-	YTX12-BS	-
	6T, T20B		-	-	-	6N11A-1B		TRX850	'95-'99	-	-	YTX12-BS	-
	Daytona 600/650, Speed Four	'02-'05	-	-	YTX9-BS	-		XS850 (All)	'80-'81	-	YTX14AHL-BS	-	SYB14L-A2†
	TT600	'00-'03	-	-	YTX12-BS	-		FZ-09	'14-'17	-	YTZ10S	-	-
500	500 (12V)		Not available	-	-	-		FJ-09	'15-'17	-	YTZ10S	-	-
	5TA, TR5A/R		-	-	-	6N11A-1B		XSR900	'16-'17	-	YTZ10S	-	-
350	350 (6V)		-	-	-	6N11A-1B	800	FZ8	'11-'13	-	YTZ10S	-	-
	350 (12V)		Not available	-	-	-	750	FZ750, FZR750	'85-'88	-	YTX14AHL-BS	-	SYB14L-A2†
	350 3TA, Twenty One		-	-	-	B38-6A		TX750	'73-'74	GYZ20HL	YTX20L-BS	YB16L-B	
250	Tigriss (6V)		-	-	-	6N11A-1B		XJ750 Maxim	'82-'83	-	YTX14AHL-BS	-	SYB14L-A2†
	Tigriss (12V)		-	-	-	6N11A-1B (x2)		XJ750M Midnight Maxim	'83	-	YTX14AHL-BS	-	SYB14L-A2†
200	Tiger		-	-	-	6N11A-1B		XJ750R Seca	'81-'83	-	YTX14AHL-BS	-	SYB14L-A2†
183	Tigriss		-	-	-	6N11A-1B		XS750 (All)	'77-'79	-	YTX14AHL-BS	-	SYB14L-A2†
								XV750 Virago (All)	'81-'96	-	-	-	YB16AL-A2
								YZF750R	'94-'98	-	-	YTX12-BS	-
								YZF-R7	'99	-	-	YT9B-BS	-
							700	FZ700, Fazer	'86-'87	-	YTX14AHL-BS	-	SYB14L-A2†
								FZ-07	'15-'17	-	YTZ10S	-	-
								MT07	'18	-	YTZ10S	-	-
								XJ700 Maxim, XJ700X	'85-'86	-	YTX14AHL-BS	-	SYB14L-A2†
								XV700 Virago	'84-'87	-	-	-	YB16AL-A2
								XSR700	'18	-	YTZ10S	-	-
							650	TX650	'74	-	YTX14AHL-BS	-	SYB14L-A2†
								TX650	'73	-	-	-	YB12A-A*
								XJ650 (All)	'80-'83	-	-	-	YB12A-A*
								XS1	'70-'71	-	-	-	12N5.5-3B
								XS2	'72	-	-	-	YB12A-A*
								XS650	'75-'83	-	YTX14AHL-BS	-	-
								XV650 V-Star (All)	'98-'16	-	-	YT12B-BS	-
							600	FJ600	'84-'85	-	-	-	YB12A-A*
								FZ6, R	'05-'17	-	-	YT12B-BS	-
								FZ600	'86-'88	-	-	-	YB12A-A*
								FZR600/R	'89-'99	-	-	-	YB12AL-A2
								SRX600	'86	-	-	-	YB5L-B*
								XJ600S Seca II	'92-'98	-	-	YTX9-BS	-
								MT600	'84-'89	-	-	-	YB5L-B*
								XT600E	'90-'95	-	-	YTX9-BS	-
								YX600 Radian	'86-'90	-	-	-	YB12A-A*
								YZF-R6 (Excl. R6S)	'06-'16	-	YTZ10S	-	-
								YZF-R6 (Excl. R6S)	'17-'20	-	YTZ7S	-	-
								YZF-R6, R6S	'01-'09	-	-	YT9B-BS	-
								YZF-R6	'99-'00	-	-	YT12B-BS	-
								YZF600R	'95-'07	-	-	YTZ12-BS	-
								XJ550 Maxim, R Seca	'81-'83	-	-	-	YB12A-A*
								XT550	'82-'83	-	-	-	YB5L-B*
								XZ550R Vision	'82-'83	-	YTX14AHL-BS	-	SYB14L-A2†
								XV535 Virago	'87-'99	-	-	-	YB12AL-A2
								SR500	'78-'99	-	-	-	YB7L-B*
								TX500	'73-'74	-	YTX14AHL-BS	-	SYB14L-A2†
								XS500	'75-'78	-	YTX14AHL-BS	-	SYB14L-A2†
								XT500	'76-'81	-	-	-	6N6-3B-1
								XV500 Virago	'83	-	-	-	YB12A-A*
							450	WR450F	'03-'20	-	YTZ7S	-	-
								YZ450FX	'16-'18	-	YTZ7S	-	-
								YZ450FX	'19-'20	Not Available	-	-	-
							400	DT400 Enduro	'77-'78	-	-	-	6N6-3B-1
								DT400 Enduro	'75-'76	-	-	-	6N4B-2A-3
								FZR400 (All)	'88-'90	-	-	-	YB12AL-A2
								RD400	'76-'79	-	-	-	12N5.5A-3B
								XS400 (All)	'80-'83	-	-	-	YB12A-A*
								SR400	'78-'00	-	-	-	YB7L-B*
								SR400	'15-'17	-	-	YT4B-BS	-
							360	DT360 Enduro	'74	-	-	-	6N4B-2A-3
								RT1, RT1B 360 Enduro	'70-'71	-	-	-	6N2-2A-3
								RT2, RT3 360 Enduro	'72-'73	-	-	-	6N4-2A-5

## CC (C) VICTORY

## YAMAHA

\* See Battery Cross Reference Chart on page 17  
 † Top and front terminal mounts only  
 (x2) Order two batteries

† This battery includes a sensor  
 † Top and front terminal mounts only and eliminates need for sensor (needs to be disabled)

CC	Model	Year	GYZ Series AGM	High Performance AGM	AGM	Yumicron / Conventional	CC	Model	Year	GYZ Series AGM	High Performance AGM	AGM	Yumicron / Conventional
	XS360	'76-'78	-	-	-	YB12A-A*	175	CT1, CT1B, CT1C 175 Enduro	'69-'71	-	-	-	6N2-2A-3
	XS360-2	'77	-	-	-	YB7L-B*		CT2, CT3 175 Enduro	'72-'73	-	-	-	6N4A-4D
350	BW350 Big Wheel	'87-'88	-	-	-	YB12B-B2		DT175 Enduro	'78-'81	-	-	-	6N6-3B-1
	R3	'69	-	-	-	YB5L-B*		DT175 Enduro	'74-'76	-	-	-	6N4B-2A-3
	R5, R5B, R5C	'70-'72	-	-	-	12N5.5A-3B	125	AS2C	'69	-	-	-	12N5.5-3B
	RD350	'73-'75	-	-	-	12N5.5A-3B		AT1E, AT1B, AT1C 125 Enduro	'69-'71	-	-	-	YB7L-B*
	RZ350	'84-'85	-	-	-	12N5.5-3B		AT2, AT3 125 Enduro	'72-'73	-	-	-	YB7L-B*
	XT350	'85-'00	-	-	-	YB3L-B		DT125 Enduro	'74-'81	-	-	-	YB7L-B*
	YR2/C	'68	-	-	-	12N5.5-3B		RD125	'75-'76	-	-	-	12N5.5A-3B
321	YZF-R3	'15-'20	-	YTZ8V	-	-		TTR125E/LE (Electric Start)	'03-'20	-	YTZ5S-BS	YTX4L-BS	-
250	DS6B, DS6C	'69-'70	-	-	-	YB5L-B*		XT125	'82-'83	-	-	-	6N4A-4D
	DS7	'72	-	-	-	12N5.5A-3B		YA6	'64-'66	-	-	-	YB10L-B
	DT1 250 Enduro	'68	-	-	-	6N2-2A-3		YAS1/C	'68	-	-	-	12N5.5-3B
	DT1B, DT1C, DT1E 250 Enduro	'69-'71	-	-	-	6N2-2A-3	110	TTR110E (Electric Start)	'08-'20	-	-	YT4B-BS	-
	DT2 250 Enduro	'72	-	-	-	6N4-2A-5	100	DT100 Enduro	'77-'83	-	-	-	6N4-2A-5
	DT250 Enduro	'77-'79	-	-	-	6N6-3B-1		DT100 Enduro	'74-'76	-	-	-	6N4B-2A-3
	DT250 Enduro	'74-'76	-	-	-	6N4B-2A-3		L5T, L5TA	'69-'70	-	-	-	YB7L-B*
	DT3 250 Enduro	'73	-	-	-	6N4-2A-5		LS2	'72	-	-	-	12N5.5A-3B
	RD250	'73-'75	-	-	-	12N5.5A-3B		LT2, LT3 100 Enduro	'72-'73	-	-	-	6N4A-4D
	SR250 Exciter	'80-'82	-	-	-	YB12A-A*		RS100	'75-'76	-	-	-	6N4A-4D
	SRX250	'87	-	-	-	YB12A-A*		YL2C/CM	'68	-	-	-	YB7L-B*
	TTR250	'99-'06	-	-	YT7B-BS	-		HS1, HS1B	'70-'71	-	-	-	12N5.5-3B
	WR250R, X	'08-'20	-	YTZ7S	-	-		HT1, HT1B 90 Enduro	'70-'71	-	-	-	6N2-2A-3
	WR250F	'03-'07	-	YTZ7S	YTX5L-BS	-		TTR90E (Electric Start)	'03-'07	-	-	YT4B-BS	-
	WR250F	'08-'20	-	YTZ7S	-	-	80	DT80 Mini Enduro	'81-'83	-	-	-	6N4-2A-5
	XT250	'08-'20	-	YTZ7S	YTX5L-BS	-		G6S, G6SB	'70-'71	-	-	-	6N4A-4D
	XT250	'84	-	-	-	YB3L-B		G7S	'72	-	-	-	6N4A-4D
	XT250	'80-'83	-	-	-	6N6-3B-1		GT1 Mini Enduro	'73	-	-	-	6N4-2A-5
	XV250, Route 66, Virago, V Star	'85-'20	-	-	-	YB10L-A2*		GT80 Mini Enduro	'74-'80	-	-	-	6N4-2A-5
	YZ250FX	'15-'17	-	YTZ7S	YTX5L-BS	-		LB80 Chappy	'76-'78	-	-	-	6N4-2A-5
230	TTR230	'05-'20	-	YTZ7S	YTX5L-BS	-		YG1	'62-'66	-	-	-	6N4A-4D
225	TTR225	'99-'05	-	-	-	YB7B-B		YG5T, YG5S	'68-'69	-	-	-	YB7L-B*
	XT225	'01-'07	-	YTZ7S	YTX5L-BS	-	60	JT2 Mini Enduro	'72	-	-	-	6N2-2A-3
	XT225 Serow	'92-'00	-	YTZ8V	YTX7L-BS	-		RD60	'73-'75	-	-	-	6N4A-4D
200	BW200E Big Wheel (Electric Start)	'86-'88	-	-	-	YB7C-A	50	DT50 Enduro	'88-'90	-	-	-	6N4B-2A-3
	CS3B, CS3C	'70-'71	-	-	-	YB9L-A2		LB50P Chappy	'78-'82	-	-	-	6N4-2A-5
	CS5	'72	-	-	-	YB9L-A2		LC50 Champ	'80-'81	-	-	-	6N4-2A-5
	RD200	'74-'76	-	-	-	YB9L-A2		MJ50 Towny	'82	-	-	-	6N4-2A-5
	TW200	'87-'20	-	-	-	YB7C-A		QT50 Yamahopper	'79-'87	-	-	-	6N4-2A-5
	XT200	'82-'83	-	-	-	6N4A-4D		RX50 Special	'83-'84	-	-	-	6N4-2A-5
	YCS1	'68	-	-	-	YB9L-A2		TTR50E	'06-'20	-	-	YT4B-BS	-
185	SR185 Exciter	'81-'82	-	-	-	YB7L-B		YSR50	'87-'92	-	-	-	6N4-2A-5

\* See Battery Cross Reference Chart on page 17

## UTV (SIDE-BY-SIDES) APPLICATIONS

CC	Model	Year	GYZ Series AGM	High Performance AGM	AGM	Yumicron / Conventional	CC	Model	Year	GYZ Series AGM	High Performance AGM	AGM	Yumicron / Conventional
<b>ARCTIC CAT</b>								Traxter	'17-'20	GYZ32HL	YIX30L-BS	-	-
	1000 Prowler 1000	'09-'17	GYZ32HL	YIX30L-BS	-	YB30L-B	800	Commander	'11-'20	GYZ20HL	YTX20HL <sup>FA</sup>	YTX20L <sup>FA</sup>	-
	Wildcat 1000, X, 4, LTD, XX	'12-'19	GYZ32HL	YIX30L-BS	-	-		Defender, DPS, Base, STD	'16-'20	GYZ20HL	YTX20HL <sup>FA</sup>	YTX20L <sup>FA</sup>	-
812	Prowler Pro XT, Crew	'19-'20	GYZ32HL	YIX30L-BS	-	-		Defender XT, CAB, MOS	'16-'20	GYZ32HL	YIX30L-BS	-	-
700	Prowler 700	'09	-	YTX24HL-BS	-	-		Maverick	'18-'20	GYZ20HL	YTX20HL-BS	YTX20L-BS	-
	Prowler 700	'10-'17	GYZ32HL	YIX30L-BS	-	YB30L-B		Traxter DPS, Base, STD	'16-'20	GYZ20HL	YTX20HL-BS	YTX20L-BS	-
	Prowler 700 HDX, HDX XT	'11-'17	GYZ32HL	YIX30L-BS	-	YB30L-B		Traxter Pro, XT	'17-'20	GYZ32HL	YIX30L-BS	-	-
	Wildcat Sport, Trail	'15-'19	GYZ32HL	YIX30L-BS	-	YB30L-B	427	Traxter, Defender	'17-'20	GYZ20HL	YTX20HL-BS	YTX20L-BS	-
650	Prowler 650	'06-'09	-	YTX24HL-BS*	-	Y50-N18L-A-CX	<b>HONDA</b>						
550	Prowler 550	'09	-	YTX24HL-BS	-	-	1000	Pioneer 1000	'16-'20	GYZ16H	-	-	-
	Prowler 550	'10-'15	GYZ32HL	YIX30L-BS	-	YB30L-B	700	MUV700 Big Red	'08-'13	GYZ16H	YTX14H-BS	YTX14-BS	-
500	Prowler 500	'17-'20	GYZ20HL	YTX20HL-BS	YTX20L-BS	-		Pioneer 700	'14-'20	GYZ16H	YTX14H-BS	YTX14-BS	-
	Prowler HDX500, HDX XT	'14-'17	GYZ32HL	YIX30L-BS	-	YB30L-B	500	Pioneer 500	'15-'18	GYZ16H	-	-	-
								Pioneer 500	'19-'20	GYZ16H	YTX14H-BS	YTX14-BS	-
<b>BRP (Can-Am)</b>							<b>KAWASAKI</b>						
1000	Commander	'11-'20	GYZ20HL	YTX20HL <sup>FA</sup>	YTX20L <sup>FA</sup>	-	990	Mule Pro DXT, DX	'16-'18	Not available	-	-	-
	Defender, DPS	'16-'20	GYZ20HL	YTX20HL <sup>FA</sup>	YTX20L <sup>FA</sup>	-	950	KAF950, Mule 2510, 3010 Diesel	'-10	Not available	-	-	-
	Defender XT, MAX, XMR, CAB	'16-'20	GYZ32HL	YIX30L-BS	-	-							
	Maverick	'13-'18	GYZ20HL	YTX20HL <sup>FA</sup>	YTX20L <sup>FA</sup>	-							

<sup>FA</sup> Must use factory activated battery  
 Top and front terminal mounts only

<sup>K</sup> Available at Kawasaki dealers only



# UTV (SIDE-BY-SIDES) APPLICATIONS

CC	Model	Year	GYZ Series AGM	High Performance AGM	AGM	Yumicron / Conventional	CC	Model	Year	GYZ Series AGM	High Performance AGM	AGM	Yumicron / Conventional
	Mule 4010 Diesel	'11-'13	Not available	-	-	-		Ranger Diesel	'11-'14	Not available	-	-	-
820	Mule Pro FXT, FX	'15-'20	Not available	-	-	-		Ranger XP	'13-'18	Not available	-	-	-
750	Teryx All Models (US)	'08-'18	Not available	-	-	-		Ranger Crew	'14-'19	Not available	-	-	-
	Teryx All Models (CN)	'08-'18	GYZ16H	KMX14-BS*	-	-	800	RZR	'08-'14	GYZ20HL	YTX20HL-BS	YTX20L-BS	-
620	KAF620, Mule 3010 4x4 Advantage Classic	'03-'07	GYZ20HL	YTX20HL-BS	YTX20L-BS	-		RZR 4, RZR S 800	'10-'14	GYZ20HL	YX30L-BS	-	YB30L-B
	KAF620, Mule 2500, 2510, 2520		-	YTX20HL-BS-PW	-	YB16CL-B		Ranger	'10-'14	GYZ23HL	YX30L-BS	-	YB30L-B
	KAF620, Mule 3000, 3010, 3020		GYZ20HL	YTX20HL-BS	YTX20L-BS	-	700	Ranger 6x6, 4x4	'14-'17	Not available	-	-	-
	Mule 4000	'09-'20	Not available	-	-	-	570	Ranger 6x6, 4x4	'06-'10	GYZ23HL	YX30L-BS	-	YB30L-B
	KAF620F, Mule 4010 4x4 (US)	'09-'17	Not available	-	-	-		RZR 570	'12-'19	-	YTX14AH-BS	-	YB14-B2
	KAF620F, Mule 4010 4x4 (CN)	'09-'20	GYZ20HL	YTX20HL-BS	YTX20L-BS	-		RZR 570 EPS	'13-'17	GYZ23HL	YX30L-BS	-	YB30L-B
	Mule 4010 Trans4x4, Diesel, Mule 4000	'09-'17	Not available	-	-	-		Ranger 4x4	'14-'18	-	YTX14AH-BS	-	YB14-B2
540	KAF540, Mule 2010, 2020, 2030		-	YTX20HL-BS-PW	-	YB16CL-B		Ranger 570 Full Size	'19	-	YTX14AH-BS	-	YB14-B2
450	KAF450, Mule 1000		-	YTX20HL-BS-PW	-	YB16CL-B		Ranger Crew 570-4	'16-'18	-	YTX14AH-BS	-	YB14-B2
400	KAF400, Mule 600, 610	'05-'16	-	YTX14AH-BS	-	YB14A-A2		Ranger Crew 570-6	'16-'19	-	YTX14AH-BS	-	YB14-B2
	Mule SX	'17-'20	-	YTX14AH-BS	-	YB14A-A2	500	Ranger	'19	-	YTX14AH-BS	-	YB14-B2
300	KAF300, Mule 500, 520, 550		-	YTX14AH-BS	-	YB14A-A2		Ranger 6x6, 4x4	'98-'04	GYZ23HL	YX30L-BS	-	YB30L-B
								Ranger 4x4	'04-'10	GYZ23HL	YX30L-BS	-	YB30L-B
								Ranger 4x4	'11-'13	-	YTX14AH-BS	-	YB14-B2
							425	Ranger 2x4	'02-'03	GYZ23HL	YX30L	-	YB30L-B
							400	Ranger 400, 4x4 HO	'10-'14	-	YTX14AH-BS	-	YB14-B2
							170	RZR	'16-'19	-	-	YTX12-BS	-

## KYMCO

700	UXV700	'17	GYZ20HL	YTX20HL-BS	YTX20L-BS	-
500	UXV500	'17	GYZ20HL	YTX20HL-BS	YTX20L-BS	-
450	UXV450	'17	GYZ20HL	YTX20HL-BS	YTX20L-BS	-

## POLARIS

1000	RZR XP 1000, TURBO 4	'14-'19	Not available	-	-	-
	RZR RS1	'18-'19	GYZ32HL	YX30L-BS	-	-
	Ranger General	'16-'19	Not available	-	-	-
	Ranger Diesel	'15-'18	Not available	-	-	-
900	RZR	'11-'14	GYZ32HL	YX30L-BS	-	YB30L-B
	RZR	'15-'19	Not available	-	-	-

\* Available at Kawasaki dealers only

## SUZUKI

620	QUV620F	'05	GYZ20HL	YTX20HL-BS	YTX20L-BS	-
-----	---------	-----	---------	------------	-----------	---

## YAMAHA

	Rhino	All	Not available	-	-	-
1000	YZZ1000R	'16-'20	Not available	-	-	-
700	Viking	'14-'20	Not available	-	-	-
	Wolverine	'16-'20	Not available	-	-	-

# SCOOTER APPLICATIONS

CC	Model	Year	GYZ Series AGM	High Performance AGM	AGM	Yumicron / Conventional	CC	Model	Year	GYZ Series AGM	High Performance AGM	AGM	Yumicron / Conventional
	<b>APRILIA</b>						300	NSS300 Forza	'14-'16	-	YTZ12S	-	-
850	SRV850	'12-'13	GYZ16H	YTX14H-BS	YTX14-BS	-	250	CH250 Elite	'85-'90	-	-	YTX12-BS	-
500	Scarabeo	'09-'13	-	-	YTX12-BS	-		CN250 Helix	'93-'09	-	-	YTX12-BS	-
300	Atlantic	'12	-	-	-	YB12AL-A2		NSS250 Reflex	'01-'09	-	YTZ12S	-	-
250	Sport City	'09-'13	-	-	YTX12-BS	-		PS250 Big Ruckus	'05-'08	-	YTZ12S	-	-
200	Scarabeo	'09-'13	-	-	YTX12-BS	-	150	CH150 Elite	'87	-	-	-	YB10L-B2
150	Mojito	'09-'10	-	YTZ8V	YTX7L-BS	-		CH150 Elite Deluxe	'85-'86	-	-	-	YB9-B
125	Sport City	'08-'13	-	-	-	YB9-B		SH150	'10-'12	-	YTZ8V	YTX7L-BS	-
100	Scarabeo ST	'09-'13	-	-	-	YB9-B		SH150	'13	-	YTZ7S	-	-
50	SR50	'09-'15	-	-	-	YB9-B		FES150		-	-	YTR9-BS	-
	Sport City	'08-'13	-	-	-	YB9-B		PCX150	'13	-	YTZ7S	-	-
								PCX150	'15-'19	-	YTZ8V	-	-
	<b>BMW</b>						125	CH125 Elite	'84	-	-	-	YB9-B
650	C650 GT, Sport	'11-'18	GYZ16H	YTX14H-BS	YTX14-BS	-		FES125		-	-	YTR9-BS	-
	C650 Evolution	'16-'18	-	-	YTX9-BS	-		NH125 Aero	'84	-	-	-	YB5L-B
600	C600, Sport	'13-'16	GYZ16H	YTX14H-BS	YTX14-BS	-		Pantheon 125		-	-	YTR9-BS	-
	C600	'11-'12	-	YTZ14S	-	-		PCX125	'11	-	YTZ7S	-	-
	<b>E-TON</b>							SH125	'10-'12	-	YTZ8V	YTX7L-BS	-
150	Sport 150	'12	-	-	YTX7A-BS	-		SH125	'13	-	YTZ7S	-	-
	Matrix R4-150	'12	-	-	YTX9-BS	-	110	NHX110 Elite	'10-'13	-	YTZ8V	YTX7L-BS	-
	Beamer R4-150	'12	-	-	YTX9-BS	-	80	CH80 Elite	'93-'09	-	YTZ7S	-	-
50	Beamer 50, Beamer III	'00-'12	-	YTZ7S	YTX5L-BS	-		NH80 Aero	'85	-	YTZ7S	-	-
	Matrix 50	'12	-	YTZ7S	YTX5L-BS	-		NH80MD Aero	'83-'84	-	-	-	YB5L-B
	Sport 50	'12	-	-	YTX7A-BS	-	50	CHF50 Metropolitan, II, SP	'02-'13	-	YTZ7S	-	-
								NB50 Aero	'85-'87	-	YTZ5S-BS	YTX4L-BS	-
	<b>HONDA</b>							NB50M Aero	'83-'84	-	-	-	YB4L-B
600	FSC600 Silver Wing	'02-'15	-	YTZ12S	-	-		NH50M Metropolitan	'13-'17	-	YTZ5S-BS	YTX4L-BS	-
								NN50MD Gyro	'84	-	-	-	YB4L-B
								NPS50, S Ruckus	'03-'19	-	YTZ7S	-	-
								NG50 Spree, 50D SS	'86-'87	-	YTZ5S-BS	YTX4L-BS	-

CC	Model	Year	GYZ Series AGM	High Performance AGM	AGM	Yumicron / Conventional
	NQ50 Spree	'84-'85	-	-	-	YB4L-B
	P50 Little Honda	'67-'68	-	-	-	6N4-2A-4
	PA50I Moped, PA50II	'78-'83	-	-	-	6N4B-2A-5
	SA50 Elite LX, S, SR	'88-'01	-	YTZ5S-BS	YTX4L-BS	-
	SB50 (All)	'88-'90	-	YTZ5S-BS	YTX4L-BS	-
	SE50 Elite (All)	'87	-	YTZ5S-BS	YTX4L-BS	-
	TG50 Gyro S (All)	'85-'86	-	YTZ5S-BS	YTX4L-BS	-

## HYOSUNG

250	NS3-250	'09-'16	-	-	YTX9-BS	-
100	EZ100	All Years	-	YTZ7S	YTX5L-BS	-
50	SB50 Super Cab, SD50 Sense, SF50 Prima, Rally, Sense	All Years	-	YTZ5S-BS	YTX4L-BS	-

## KYMCO

500	Xciting 500i	'09-'16	GYZ16H	YTX14H-BS	YTX14-BS	-
400	Xciting 400i	'09	-	-	YTX12-BS	-
300	Downtown 300	'13	-	-	YT12A-BS	-
	People GT	'16	-	-	YT12A-BS	-
250	People 250	'09-'11	-	-	YTX12-BS	-
	Xciting 250i	'10-'11	-	-	YTX12-BS	-
200	People S 200	'11	-	-	YTX7A-BS	-
	People GT	'13	-	-	YT12A-BS	-
150	People S 150	'09-'13	-	-	YTX7A-BS	-
	Super 8 150	'09-'16	-	-	YTX7A-BS	-
125	People S 125	'09-'10	-	-	YTX7A-BS	-
	Agility 125	'16	-	YTZ7S	YTX5L-BS	-
50	Super 8	'09-'16	-	-	YTX7A-BS	-
	Super 9	'09-'10	-	YTZ7S	YTX5L-BS	-
	People	'09-'13	-	YTZ7S	YTX5L-BS	-
	People S 50	'09-'10	-	-	YTX7A-BS	-
	Agility 50	'09-'16	-	YTZ7S	YTX5L-BS	-

## PIAGGIO

500	MP3 500 / Sport ABS	'08-'16	GYZ16H	YTX14H-BS	YTX14-BS	-
	BV500	'08-'13	GYZ16H	YTX14H-BS	YTX14-BS	-
460	X9	'09	GYZ16H	YTX14H-BS	YTX14-BS	-
400	MP3 400	'08-'13	GYZ16H	YTX14H-BS	YTX14-BS	-
350	BV350 ABS	'13-'16	-	-	YTX12-BS	-
250	MP3 250	'08-'13	GYZ16H	YTX14H-BS	YTX14-BS	-
	BV250	'08-'11	GYZ16H	YTX14H-BS	YTX14-BS	-
150	FLY150	'09-'16	-	-	-	YB9-B
50	FLY 50	'09-'16	-	-	-	YB9-B
	Typhoon	'09-'16	-	-	-	YB9-B

## PIAGGIO - GILERA

500	Fuoco 500ie	'10-'13	-	YTX20CH-BS	YTX16-BS	-
	Nexus 500ie	'10	-	YTX14HL-BS	-	SYB14L-A2†
300	Nexus 300ie	'10-'11	GYZ16H	YTX14H-BS	YTX14-BS	-
200	Runner 200	'10-'12	-	-	YTX12-BS	-
125	Runner 125	'10-'12	GYZ16H	YTX14H-BS	YTX14-BS	-
50	SP50	'10-'13	-	-	-	YB4L-B

† This battery includes a sensor

CC	Model	Year	GYZ Series AGM	High Performance AGM	AGM	Yumicron / Conventional
----	-------	------	----------------	----------------------	-----	-------------------------

## PIAGGIO - VESPA

946	Vespa 946	'13-'16	-	-	YTX12-BS	-
300	GTS300, GTV300	'10-'16	GYZ16H	YTX14H-BS	YTX14-BS	-
250	GTS250, GTV250	'10	GYZ16H	YTX14H-BS	YTX14-BS	-
150	LX150	'07	-	-	-	YB9-B
	LX150 4T	'16	-	-	-	YTX12-BS
50	LX50	'10-'16	-	-	-	YB9-B

## SYM

250	RV250	'10-'12	-	-	YTX12-BS	-
200	HD200	'10-'13	-	-	YTX9-BS	-
125	HD125	'10-'11	-	-	YTX9-BS	-
	Fiddlel1125	'10-'11	-	-	YTX7A-BS	-
50	Fiddlel150	'10-'12	-	-	YTX7A-BS	-
	SYMply50	'10-'11	-	-	YTX7A-BS	-
	MIO 50	'10-'13	-	-	YTX7A-BS	-
	JetEuro 50	'10-'12	-	YTZ7S	YTX5L-BS	-
	RSS0	'10	-	YTZ5S-BS	YTX4L-BS	-

## SUZUKI

650	AN650 Burgman	'03-'17	GYZ16H	YTX14H-BS	YTX14-BS	-
400	AN400 Burgman	'03-'19	-	-	YTX9	-
200	UH200A Burgman	'14-'19	-	-	YTX9-BS	-
50	F50, F50R	'71	-	-	-	6N4-2A
	FA50 Shuttle	'80-'91	-	-	-	6N2-2A-4
	FS50, FZ50	'79-'83	-	-	-	6N4-2A

## YAMAHA

530	T-MAX XP500F	'13-'16	-	YTZ12S	-	-
500	T-MAX XP500	'09-'13	-	YTZ10S	-	-
400	YP400 Majesty	'04-'14	-	-	YT9B-BS	-
300	Xmax	'18	-	YTZ8V	-	-
250	Morphous	'06-'08	-	YTZ10S	-	-
	Maxam	'13	-	YTZ10S	-	-
200	XC200 Riva	'87-'91	-	-	-	YB10L-B2
180	XC180 Riva	'83-'85	-	-	-	YB10L-B
155	Smax	'15-'19	-	-	YT7B-BS	-
125	XC125 Riva	'85-'01	-	-	-	YB7C-A
	YJ125T Vino 125	'04-'09	-	-	YTX7A-BS	-
	Zuma 125	'09-'19	-	-	YT7B-BS	-
80	CV80 Riva	'83-'87	-	-	-	6YB11-2D *
50	CE50 Riva Jog	'86-'87	-	-	-	YB4L-B
	CG50 Riva	'88-'91	-	-	-	YB4L-B
	CW50 Zuma	'89-'90	-	-	-	YB4L-B
	CW50 Zuma II	'97-'01	-	-	-	YB4L-B
	CV50 Riva Jog	'92-'01	-	YTZ5S-BS	YTX4L-BS	-
	SH50 Riva Razz	'87-'01	-	-	-	YB4L-B
	XC50 Vino, Classic	'01-'18	-	YTZ7S	YTX5L-BS	-
	XF50W (C3)	'07-'13	-	YTZ7S	YTX5L-BS	-
	YW50A, F, FX Zuma	'02-'19	-	YTZ7S	YTX5L-BS	-
	VOX	'13	-	YTZ7S	YTX5L-BS	-
	JOG, ZR	'13	-	YTZ7S	YTX5L-BS	-

\* See Battery Cross Reference Chart on page 17

SCOOTER

ATV

# ATV (ALL TERRAIN VEHICLE) APPLICATIONS

CC	Model	Year	GYZ Series AGM	High Performance AGM	AGM	Yumicron / Conventional
<b>AEON (BENZA)</b>						
100	Cobra/CX-Sport 100	All	-	-	YTX4L-BS	-
90	Cobra/CX-Sport 90	All	-	-	YTX4L-BS	-
50	Cobra/CX-Sport 50	All	-	-	YTX4L-BS	-

## ARCTIC CAT

1000	Thundercat	'08-'10	GYZ20H	YTX20H-BS	YTX20-BS	-
------	------------	---------	--------	-----------	----------	---

CC	Model	Year	GYZ Series AGM	High Performance AGM	AGM	Yumicron / Conventional
	Mudpro 1000H, TRV, 1000i GT, XT	'10-'17	GYZ20H	YTX20H-BS	YTX20-BS	-
700	FIS	'06-'08	GYZ20H	YTX20H-BS	YTX20-BS	-
	Diesel	'07-'15	-	YTX24HL-BS	-	-
	TRV, Mudpro, LTD, TBX	'09-'19	GYZ20H	YTX20H-BS	YTX20-BS	-
	Allterra	'16-'20	GYZ20H	YTX20H-BS	YTX20-BS	-
	XT, TRV, CORE	'13-'17	GYZ20H	YTX20H-BS	YTX20-BS	-
650	4x4 Automatic V2	'04-'06	-	-	YTX14H-BS	YB14-A2
	4x4 Automatic	'10	GYZ20H	YTX20H-BS	YTX20-BS	-

# ATV (ALL TERRAIN VEHICLE) APPLICATIONS

CC	Model	Year	GYZ Series AGM	High Performance AGM	AGM	Yumicron / Conventional
	TRV	'09	-	YTX14AH-BS	-	YB14-A2
	650H1, TBX650	'06-'09	-	YTX14AH-BS	-	YB14-A2
	Mudpro	'10-'12	GYZ20H	YTX20H-BS	YTX20-BS	-
	650, H1	'11-'12	GYZ20H	YTX20H-BS	YTX20-BS	-
545	Alterra 550, TRV, LTD, S, XT, CORE	'10-'17	GYZ20H	YTX20H-BS	YTX20-BS	-
	Alterra 570	'19-'20	GYZ20H	YTX20H-BS	-	-
500	All Other Models	'09	-	YTX14AH-BS	-	YB14-A2
	ATV 500	'13-'17	GYZ20H	YTX20H-BS	YTX20-BS	-
	Alterra	'16	GYZ20H	YTX20H-BS	YTX20-BS	-
	Alterra	'17-'18	GYZ20HL	YTX20HL-BS	YTX20L-BS	-
	TRV	'13-'20	GYZ20H	YTX20H-BS	YTX20-BS	-
450	XC450	'11-'17	GYZ20HL	YTX20HL-BS	YTX20L-BS	-
	ATV 450	'10-'12	GYZ20H	YTX20H-BS	YTX20-BS	-
	ATV 450, Alterra	'13-'16	GYZ20HL	YTX20HL-BS	YTX20L-BS	-
	TRV	'11-'12	GYZ20H	YTX20H-BS	YTX20-BS	-
	TRV, CORE	'13-'17	GYZ20HL	YTX20HL-BS	YTX20L-BS	-
400	All Models	All	-	YTX14AH-BS	-	YB14-A2
	DVX 400	All	-	-	YTX9-BS	-
	Alterra, TRV, CORE	'17	-	YTX14AH-BS	-	YB14-A2
366	366	'08-'11	-	YTX14AH-BS	-	YB14-A2
300	DVX300, Utility	'09-'16	-	-	YTX12-BS	-
	Alterra	'17-'20	-	-	YTX12-BS	-
	ATV 300, 4x4, 2x4	'98-'05	-	YTX14AHL-BS	-	SYB14L-A2†
250	All Models	'05	-	YTX14AHL-BS	-	SYB14L-A2†
	DVX250, 2x4	'06-'10	-	-	YTX12-BS	-
150	150 Utility, Alterra	'09-'19	-	-	YTX9-BS	-
90	ATV 90, Y-12 Youth, 2-Stroke	'02-'04	-	YTZ5S-BS	YTX4L-BS	-
	ATV 90, Y-12 Youth, 4-Stroke	'04-'05	-	YTZ7S	YTX5L-BS	-
	DVX90, Utility	'06-'19	-	YTZ7S	YTX5L-BS	-
	Alterra 90	'17-'20	-	YTZ7S	YTX5L-BS	-
50	DVX50, Utility	'06-'08	-	YTZ7S	YTX5L-BS	-
	ATV50 Y-6 Youth	'04-'05	-	YTZ5S-BS	YTX4L-BS	-

## BRP (Can-Am)

1000	Outlander 1000, Renegade, 6x6	'12-'20	GYZ20HL	YTX20HL <sup>FA</sup>	YTX20L <sup>FA</sup>	-
850	Outlander, Renegade	'16-'20	GYZ20HL	YTX20HL <sup>FA</sup>	YTX20L <sup>FA</sup>	-
800	Outlander 800 EFI, MAX, Renegade	'06-'19	GYZ20HL	YTX20HL <sup>FA</sup>	YTX20L <sup>FA</sup>	-
650	DS650	'00-'07	-	-	YTX15L-BS	-
	Quest	'02-'05	-	YTX20HL-BS-PW	-	YB16CL-B
	Quest (Opt)	'02-'05	-	YTX24HL-BS <sup>■</sup>	-	Y50-N18L-A-CX
	Outlander	'06-'12	GYZ20HL	YTX20HL-BS	YTX20L-BS	-
	Outlander, 6x6	'13-'20	GYZ20HL	YTX20HL <sup>FA</sup>	YTX20L <sup>FA</sup>	-
570	Outlander, Renegade	'16-'20	GYZ20HL	YTX20HL <sup>FA</sup>	YTX20L <sup>FA</sup>	-
500	Traxter (All Models), Quest	'99-'05	-	YTX20HL-BS-PW	-	YB16CL-B
	Traxter (All Models), Quest (Opt)	'02-'05	-	YTX24HL-BS <sup>■</sup>	-	Y50-N18L-A-CX
	Outlander, MAX, Renegade	'07-'15	GYZ20HL	YTX20HL <sup>FA</sup>	YTX20L <sup>FA</sup>	-
450	DS450	'08-'15	-	-	YT7B-BS	-
	Outlander	'16-'20	GYZ20HL	YTX20HL <sup>FA</sup>	YTX20L <sup>FA</sup>	-
400	Outlander 400	'03-'04	-	-	YTX15L-BS	-
	Outlander 400, XT, MAX	'04-'15	GYZ20HL	YTX20HL <sup>FA</sup>	YTX20L <sup>FA</sup>	-
330	Outlander 330	'04-'05	-	-	YTX15L-BS	-
250	DS250	'06-'19	-	-	YTX12-BS	-
200	Rally	'02-'06	-	YTX14AH-BS	-	YB14A-A2
90	DS90, DS90F, Quest	'02-'19	-	YTZ5S-BS	YTX4L-BS	-
70	DS70	'08-'19	-	YTZ5S-BS	YTX4L-BS	-
50	DS50, Quest	'02-'06	-	YTZ5S-BS	YTX4L-BS	-

## CF MOTO

800	Cforce 800	'12-'19	GYZ32HL	YIX30L-BS	-	-
600	Cforce 600	'19	GYZ32HL	YIX30L-BS	-	-
500	Cforce 500	'16-'19	GYZ32HL	YIX30L-BS	-	-
	Cforce 500	'07-'14	GYZ20HL	YTX20HL-BS	YTX20L-BS	-
400	Cforce 400	'16-'19	GYZ32HL	YIX30L-BS	-	-

## E-TON

250	Vector250	'13	-	-	YTX12-BS	-
150	CXL150 Yukon II	'00-'13	-	-	YTX9-BS	-
	YXL150 Yukon	'00-'03	-	-	YTX9-BS	-
	Viper150R	'13	-	-	YTX9-BS	-
90	All models	'04-'13	-	YTZ7S	YTX5L-BS	-
	AXL, TXL, NXL, RXL	'99-'03	-	YTZ5S-BS	YTX4L-BS	-
	DXL90 Sierra	'99-'03	-	YTZ5S-BS	YTX4L-BS	-

CC	Model	Year	GYZ Series AGM	High Performance AGM	AGM	Yumicron / Conventional
70	Viper 70	'13	-	YTZ7S	YTX5L-BS	-
50	All models	'04-'05	-	YTZ7S	YTX5L-BS	-
	AXL, TXL, NXL, RXL	'99-'03	-	YTZ5S-BS	YTX4L-BS	-

## HONDA

700	TRX700X	'08-'13	-	-	YTX9-BS	-
680	TRX680FA FourTrax Rincon	'06-'20	GYZ20HL	YTX20HL-BS	YTX20L-BS	-
650	TRX650 FourTrax Rincon (Std.)	'03-'05	GYZ16H	YTX14H-BS	YTX14-BS	-
520	TRX520	'20	GYZ16H	-	-	-
500	TRX500FA FourTrax Rubicon	'01-'14	GYZ16H	YTX14H-BS	YTX14-BS	-
	TRX500FA	'15-'19	GYZ16H	-	-	-
	TRX500FE, FM, TM Trax Foreman	'05-'11	GYZ16H	YTX14H-BS	YTX14-BS	-
	FourTrax Foreman ES, 4x4	'05-'09	GYZ16H	YTX14H-BS	YTX14-BS	-
	TRX500FE, FPE, FM, FPM	'11-'19	GYZ16H	-	-	-
450	TRX450 FourTrax Foreman S, ES	'98-'04	GYZ16H	YTX14H-BS	YTX14-BS	-
	TRX450ER, TRX450R	'06-'13	-	YTZ7S	YTX5L-BS	-
420	TRX420 FourTrax Rancher 4x4	'13	GYZ16H	YTX14H-BS	YTX14-BS	-
	TRX420 FourTrax Rancher 4x4	'14-'19	GYZ16H	-	-	-
	TRX420 FourTrax Rancher 2x4	'20	GYZ16H	YTX14H-BS	YTX14-BS	-
400	FL400R Pilot	'89-'90	GYZ16H	YTX14H-BS	YTX14-BS	-
	TRX400 Rancher AT	'04-'06	GYZ16H	YTX14H-BS	YTX14-BS	-
	TRX400X, EX, FourTrax, Sportrax	'99-'13	-	-	YTX9-BS	-
	TRX400FW Foreman	'95-'03	GYZ16H	YTX14H-BS	YTX14-BS	-
350	FL350R Odyssey	'85	-	-	YTX12-BS	-
	TRX350 Rancher	'00-'06	GYZ16H	YTX14H-BS	YTX14-BS	-
	TRX350, D FourTrax 4x4	'86-'89	GYZ16H	YTX14H-BS	YTX14-BS	-
300	TRX300 FourTrax	'88-'00	GYZ16H	YTX14H-BS	YTX14-BS	-
	TRX300X, EX	'93-'12	-	-	YTX9-BS	-
	TRX300FW FourTrax 4x4	'88-'00	GYZ16H	YTX14H-BS	YTX14-BS	-
250	ATC250ES Big Red	'85-'87	-	-	YTX12-BS	-
	ATC250SX	'85-'87	-	-	YTX12-BS	-
	TRX250X, EX	'01-'20	-	-	YTX9-BS	-
	TRX250 FourTrax	'85-'87	-	-	YTX12-BS	-
	TRX250 TE, TM, FourTrax Recon	'97-'20	-	-	YTX12-BS	-
	TRX250 Recon, ES	'97-'03	-	-	YTX12-BS	-
200	ATC200 Big Red	'82-'84	-	YTX14AH-BS	-	YB14A-A2
	ATC200M	'84-'85	-	YTX14AH-BS	-	YB14A-A2
	TRX200 FourTrax	'90-'97	-	-	YTX12-BS	-
	TRX200 FourTrax	'84	-	YTX14AH-BS	-	YB14A-A2
	TRX200SX FourTrax	'86-'88	-	-	YTX12-BS	-
125	ATC125M	'86-'87	-	-	YTX12-BS	-
	ATC125M	'84-'85	-	-	-	YB9A-A
	TRX125 FourTrax	'87-'88	-	-	YTX9-BS	-
	TRX125 FourTrax	'85-'86	-	-	-	YB9A-A
90	TRX90X, EX	'06-'20	-	YTZ7S	YTX5L-BS	-

## HYOSUNG

450	TE450S	'13	-	-	YTX9-BS	-
-----	--------	-----	---	---	---------	---

## JOHN DEERE

	All Models	All	-	YTX20HL-BS-PW	-	YB16CL-B
--	------------	-----	---	---------------	---	----------

## KASEA

250	Skyhawk 250	All	-	-	YTX7A-BS	-
170	Skyhawk 170	All	-	-	YTX7A-BS	-
150	Skyhawk 150, Adventure Buggy	All	-	-	YTX7A-BS	-
125	KS, KU Models, Adventure Buggy	All	-	-	YTX7A-BS	-
90	KS, KU Models	All	-	-	YTX7A-BS	-
	Skyhawk 90	All	-	YTZ7S	YTX5L-BS	-
65	KS, KU Models	All	-	-	YTX7A-BS	-
50	Mini Skyhawk	All	-	YTZ5S-BS	YTX4L-BS	-
	Skyhawk 50	All	-	YTZ7S	YTX5L-BS	-

## KAWASAKI

750	KVF750 Brute Force, EPS	'05-'20	GYZ16H	-	KMX14-BS <sup>K</sup>	-
700	KF700	'03-'10	GYZ16H	-	KMX14-BS <sup>K</sup>	-
	KVF700-A, B, D Prairie 700, 4x4	'04-'06	GYZ16H	-	KMX14-BS <sup>K</sup>	-
650	KVF650 Brute Force	'02-'13	GYZ16H	-	KMX14-BS <sup>K</sup>	-
450	KFX450R	'08-'14	-	YTZ8V	YTX7L-BS	-

<sup>FA</sup> Must use factory activated battery  
<sup>■</sup> Top and front terminal mounts only

<sup>K</sup> Available at Kawasaki dealers only  
<sup>†</sup> This battery includes a sensor



# ATV (ALL TERRAIN VEHICLE) APPLICATIONS

CC	Model	Year	GYZ Series AGM	High Performance AGM	AGM	Yumicron / Conventional	CC	Model	Year	GYZ Series AGM	High Performance AGM	AGM	Yumicron / Conventional	
400	4x4 Advantage Classic	'02-'03	GYZ16H	-	KMX14-BS <sup>K</sup>	-	700	Sportsman, Military	'02-'08	GYZ32HL	YX30L-BS	-	YB30L-B	
	KLF400-B Bayou 400 4x4	'93-'00	-	YTX20HL-BS-PW	-	YB16CL-B	-	Sportsman	'10	GYZ32HL	YX30L-BS	-	YB30L-B	
	KSF400-A (KFX400)	'03-'06	-	-	YTX9-BS	-	600	Sportsman	'04-'05	GYZ32HL	YX30L-BS	-	YB30L-B	
	KVF400-A Prairie 400 4x4	'97-'00	-	YTX14AH-BS	-	YB14A-A2	-	570	Sportsman	'14-'19	-	YTX14AH-BS	-	YB14A-A2
	KVF400-A Prairie 400 4x4 (CN)	'97-'00	-	YTX20HL-BS-PW	-	YB16CL-B	-	ACE, ACE SP	'15-'19	-	YTX14AH-BS	-	YB14A-A2	
	KVF400-B Bayou 400 4x4	'98-'00	-	YTX14AH-BS	-	YB14A-A2	-	550	Sportsman Touring, XP, X2	'09	GYZ20HL	YTX20HL-BS	YTX20L-BS	-
	KVF400-B Prairie 400 4x4 (CN)	'98-'00	-	YTX20HL-BS-PW	-	YB16CL-B	-	Sportsman Touring, X2	'10	GYZ20HL	YTX20HL-BS	YTX20L-BS	-	
	KVF400-C Prairie 400, 4x4	'99-'02	-	YTX14AH-BS	-	YB14A-A2	-	Sportsman XP	'10	-	YTX14AH <sup>FA</sup>	-	-	-
	KVF400-C Prairie 400, 4x4 (CN)	'99-'02	GYZ16H	-	KMX14-BS <sup>K</sup>	-	Sportsman EPS, X2, Touring	'10-'14	-	YTX14AH <sup>FA</sup>	-	-	-	
	KVF400-D Prairie 400, 4x4	'99-'02	-	YTX14AH-BS	-	YB14A-A2	-	525	Outlaw 525	'08-'12	-	-	YTX9-BS	-
	KVF400-D Prairie 400, 4x4 (CN)	'99-'01	GYZ16H	-	KMX14-BS <sup>K</sup>	-	500	All Models (Excl. Predator, Sportsman)	'99-'12	-	YTX14AH-BS	-	YB14A-A2	
	KVF360 Prairie	'13	-	YTX14AH-BS	-	YB14A-A2	-	Sportsman HO	'96-'13	-	YTX14AH-BS	-	YB14A-A2	
	KEF300-A Lakota	'95-'00	-	YTX14AH-BS	-	YB14A-A2	-	Sportsman EFI	'06	GYZ32HL	YX30L-BS	-	YB30L-B	
	KEF300-A Lakota Sport	'01-'03	-	YTX14AH-BS	-	YB14A-A2	-	Sportsman EFI	'07-'10	GYZ20HL	YTX20HL-BS	YTX20L-BS	-	
	KEF300-B Lakota Sport	'01-'03	-	YTX14AH-BS	-	YB14A-A2	-	Predator, Outlaw	'03-'06	-	-	YTX9-BS	-	
	KLF300-A Bayou	'86-'87	-	YTX20HL-BS-PW	-	YB16CL-B	-	ACE 500 SOHC	'18-'19	-	YTX14AH-BS	-	YB14A-A2	
	KLF300-B Bayou	'88-'04	-	YTX14AH-BS	-	YB14A-A2	-	ACE500 SOHC (opt)	'18-'19	GYZ32HL	-	-	-	
	KLF300-B Bayou (CN)	'92-'99	-	YTX20HL-BS-PW	-	YB16CL-B	-	450	Sportsman HO, HD 2X4	'16-'19	-	YTX14AH-BS	-	YB14A-A2
	KLF300-C Bayou 300 4x4	'89-'04	-	YTX14AH-BS	-	YB14A-A2	-	Diesel .445 Litre (primary)	'99-'03	GYZ32HL	YX30L-BS	-	YB30L-B	
	KLF300-C Bayou 300 4x4 (CN)	'92-'05	-	YTX20HL-BS-PW	-	YB16CL-B	-	Diesel .445 Litre (secondary)	'99-'03	-	YTX14AH-BS	-	YB14A-A2	
	KVF300-A Prairie 300, 4x4	'99-'02	-	YTX14AH-BS	-	YB14A-A2	-	Outlaw 450	'07-'10	-	-	YTX9-BS	-	
	KVF300-A Prairie 300, 4x4 (CN)	'99-'01	-	YTX20HL-BS-PW	-	YB16CL-B	-	425	All Models	'95-'02	-	YTX14AH-BS	-	YB14A-A2
	KVF300-B Prairie 300, 4x4	'99-'02	-	YTX14AH-BS	-	YB14A-A2	-	400	All Models	'94-'14	-	YTX14AH-BS	-	YB14A-A2
	KVF300-B Prairie 300, 4x4 (CN)	'99-'02	-	YTX20HL-BS-PW	-	YB16CL-B	-	335	Sportsman	'98-'01	-	YTX14AH-BS	-	YB14A-A2
	KVF300-Brute Force	'13-'20	-	-	YTX12-BS	-	330	Magnum, Trail	'03-'13	-	YTX14AH-BS	-	YB14A-A2	
250	KLF250-A Bayou	'03-'12	-	-	-	YB10A-A2	325	ACE	'14-'16	GYZ32HL	YX30L-BS	-	YB30L-B	
KLF250-A Bayou (CN)	'03-'05	-	YTX14AH-BS	-	YB14A-A2	-	All Models	'87-'02	-	YTX14AH-BS	-	YB14A-A2		
KLT250-A	'82-'83	-	-	-	YB12A-A	-	300	Hawkeye, Sportsman 300	'06-'10	-	YTX14AH-BS	-	YB14A-B2	
KLT250-C Prairie	'83	-	-	-	YB12A-A	-	250	All models	'85-'05	-	YTX14AH-BS	-	YB14A-A2	
KLT250-C Prairie	'84-'85	-	-	-	YB10L-B	-	200	Phoenix, Sawtooth	'05-'19	-	-	YTX12-BS	-	
220	KLF220-A Bayou	'88-'02	-	-	-	YB10A-A2	150	ACE EFI	'19	-	-	YTX9-BS	-	
KLF220-A Bayou (CN)	'92-'02	-	YTX14AH-BS	-	YB14A-A2	-	ATV Ranger	'18-'19	-	-	YTX9-BS	-		
KLT200-A, C	'81-'84	-	-	-	YB10L-B	-	110	Outlaw	'16-'19	-	YTX5L-BS	-		
KLT200-B, C	'83	-	-	-	YB12A-A	-	Sportsman	'16-'19	-	YTX7S	YTX5L-BS	-		
185	KLF185-A Bayou	'85-'88	-	-	-	YB10L-B	90	Predator, Sportsman, Outlaw	'03-'14	-	YTX7S	YTX5L-BS	-	
110	KLF110-B Mojave	'87-'88	-	-	-	YB9L-A2	90	Scrambler, Sportsman	'01-'02	-	YTX5S-BS	YTX4L-BS	-	
90	KFX90	'07-'20	-	YTZ7S	YTX5L-BS	-	50	Outlaw, Predator (-'07)	'04-'19	-	YTX7S	YTX5L-BS	-	
80	KSF80-A (KFX80)	'03-'05	-	YTZ7S	YTX5L-BS	-	50	Scrambler	'01-'02	-	YTX25S-BS	YTX4L-BS	-	
50	KFX50	'07-'20	-	YTZ7S	YTX5L-BS	-	Scrambler	'03	-	YTZ7S	YTX5L-BS	-		

## KTM

525	XC ATV	'10-'13	-	YTZ7S	YTX5L-BS	-
505	SX ATV	'08-'13	-	YTZ7S	YTX5L-BS	-
XC ATV	'08-'09	-	YTZ7S	YTX5L-BS	-	
450	SX ATV	'08-'12	-	YTZ7S	YTX5L-BS	-
XC ATV	'08-'12	-	YTZ7S	YTX5L-BS	-	

## KYMCO

700	MXU700	'17	GYZ20HL	YTX20HL-BS	YTX20L-BS	-
500	MXU500	'17	GYZ20HL	YTX20HL-BS	YTX20L-BS	-
450	Maxxer 450, MXU 450	'17	GYZ20HL	YTX20HL-BS	YTX20L-BS	-
300	MXU300SD	All	-	YTX12-BS	-	-
Mongoose300	All	-	-	YTX12-BS	-	-
250	Mongoose, MXU	All	-	YTX12-BS	-	-
150	MXU150	All	-	YTX9-BS	-	-
90	Mongoose 90	All	-	YTZ7S	YTX5L-BS	-
50	Mongoose 50	All	-	YTZ7S	YTX5L-BS	-

## POLARIS

1000	Sportsman XP 48, 55	'19-'20	GYZ32HL <sup>*</sup>	YX30L-BS	-	-
Sportsman XP, Touring XP, HL ('16)	'16-'19	GYZ20HL <sup>*</sup>	YX20HL <sup>FA</sup>	-	-	-
Sportsman XP, Touring XP	'15	GYZ20HL <sup>*</sup>	YTX20HL <sup>FA</sup>	-	-	-
Scrambler XP (55")	'20	GYZ32HL <sup>*</sup>	YX30L <sup>FA</sup>	-	-	-
Scrambler	'16-'19	GYZ20HL <sup>*</sup>	YX20HL <sup>FA</sup>	-	-	-
Scrambler	'14-'15	GYZ20HL <sup>*</sup>	YTX20HL <sup>FA</sup>	-	-	-
900	ACE SP	'16-'19	GYZ32HL <sup>*</sup>	YX30L-BS	-	YB30L-B
850	Sportsman (opt.), WV(std.)	'09-'18	-	YX30L <sup>FA</sup>	-	-
Sportsman, SP, Touring XP, HL ('16)	'10-'18	GYZ20HL <sup>*</sup>	YX20HL <sup>FA</sup>	-	-	-
Scrambler 48, Sportsman 48	'19	GYZ32HL <sup>*</sup>	YX30L <sup>FA</sup>	-	-	-
Scrambler	'16-'18	GYZ20HL <sup>*</sup>	YX20HL	-	-	-
Scrambler	'13-'15	GYZ20HL <sup>*</sup>	YTX20HL <sup>FA</sup>	-	-	-
800	Sportsman	'05-'10	GYZ32HL	YX30L-BS	-	-
Sportsman	'11-'14	GYZ20HL	YTX20HL-BS	YTX20L-BS	-	-
Sportsman 6x6	'14	-	YX30L <sup>FA</sup>	-	-	-

## QIANJIANG

100	ATV100	All	-	YTZ5S-BS	YTX4L-BS	-
50	ATV50	All	-	YTZ5S-BS	YTX4L-BS	-

## SUZUKI

750	LT-A750X King Quad	'07-'18	-	YTX20CH-BS	-	-
700	LT-A700X King Quad	'05-'07	-	YTX20CH-BS	-	-
LT-V700F Twin Peaks	'04-'05	GYZ16H	YTX14H <sup>FA</sup>	YTX14-BS	-	-
500	LT-A500F QuadMaster	'00-'01	-	-	YTX16-BS-1	-
LT-A500F Vinson 4WD	'04-'07	-	-	YTX20CH-BS	-	-
LT-A500F Vinson 4WD	'02-'03	-	-	YTX20CH-BS	YTX16-BS	-
LT-F500F Vinson Manual 4WD	'04-'07	-	-	YTX20CH-BS	-	-
LT-F500F Vinson Manual 4WD	'03	-	-	YTX20CH-BS	YTX16-BS	-
LT-A500X King Quad	'11-'18	-	-	YTX20CH-BS	-	-
450	LT-A450 King Quad	'07-'11	GYZ16H	YTX14H-BS	YTX14-BS	-
LT-R450 QuadRacer	'06-'11	-	-	-	YTX7A-BS	-
400	LT-A400 Eiger 2WD, F Eiger 4WD	'02-'07	GYZ16H	YTX14H-BS	YTX14-BS	-
LT-F400 Eiger 2WD, F Eiger 4WD	'02-'07	GYZ16H	YTX14H-BS	YTX14-BS	-	-
LT-Z400 QuadSport	'03-'16	-	-	-	YTX9-BS	-
LT-A400F, F400F King Quad	'10-'18	GYZ16H	YTX14H-BS	YTX14-BS	-	-
300	LT-F4WDX KingQuad	'99-'02	-	YTX14AH-BS	-	-
LT-F4WDX KingQuad (Opt)	'99-'02	-	-	-	Y50-N18A-A	-
LT300E QuadRunner 300E	'87-'89	-	-	YTX14AH-BS	-	YB14A-A2
LT-F300F KingQuad	'99-'02	-	-	YTX14AH-BS	-	YB14A-A2
LT-F300F KingQuad (CN, Opt)	'99-'02	-	-	-	Y50-N18A-A	-
280	LT-F4WDX KingQuad	'91-'99	-	YTX14AH-BS	-	YB14A-A2
LT-F4WDX KingQuad (CN, Opt)	'91-'99	-	-	-	Y50-N18A-A	-
250	LT250EF QuadRunner	'85-'86	-	-	Y50-N18A-A	-
LT-4WD QuadRunner	'87-'99	-	-	YTX14AH-BS	-	YB14A-A2
LT-4WD QuadRunner (Opt)	'87-'99	-	-	-	Y50-N18A-A	-
LT-F250 QuadRunner	'88-'01	-	-	YTX14AH-BS	-	YB14A-A2
LT-F250 QuadRunner (Opt)	'88-'01	-	-	-	Y50-N18A-A	-
LT-F250, Ozark	'02-'16	-	-	-	YTX12-BS	-

<sup>K</sup> Available at Kawasaki dealers only  
<sup>\*</sup> See Battery Cross Reference Chart on page 17

<sup>FA</sup> Must use Factory Activated battery

# ATV (ALL TERRAIN VEHICLE) APPLICATIONS

CC	Model	Year	GYZ Series AGM	High Performance AGM	AGM	Yumicron / Conventional	CC	Model	Year	GYZ Series AGM	High Performance AGM	AGM	Yumicron / Conventional	
	LT-F250F QuadRunner	'99-'02	-	YTX14AH-BS	-	YB14A-A2		YFM40FW Kodiak	'93-'95	-	YTX14AH-BS	-	YB14A-A1	
	LT-F250F QuadRunner (CN, Opt)	'99-'02	-	-	-	Y50-N18A-A		YFM40FW Kodiak/Automatic	'03-'06	-	YTX14AH-BS	-	-	
	LT-Z250 QuadSport	'04-'11	-	-	YTX9-BS	-		YFM40FW Kodiak/Automatic	'96-'02	GYZ20HL	YTX20HL-BS	YTX20L-BS	-	
230	LT230E QuadRunner	'87	Not available	-	-	-		YFM40FWM Big Bear	'00-'03	GYZ20HL	YTX20HL-BS	YTX20L-BS	-	
	LT230E QuadRunner	'88-'93	-	-	YTX12-BS	-	350	YFM35B Bruin	'04-'06	-	YTX14AH-BS	-	-	
	LT230GE QuadRunner	'85-'86	-	-	-	YB10A-A2		YFM35ER Moto 4	'87-'95	-	YTX14AH-BS	-	YB14A-A1	
	LT-F230 QuadRunner	'86-'87	-	-	-	YB10A-A2		YFM35F U Big Bear	'87-'99	-	YTX14AH-BS	-	YB14A-A1	
160	LT160 E QuadRunner	'89-'94	-	-	-	YB9A-A		YFM35FX Wolverine	'95-'05	-	-	-	YB12C-A	
	LT160 E QuadRunner	'03-'04	-	-	-	YB9A-A		YFM35FX Wolverine	'06-'09	-	YTX14AH-BS	-	-	
	LT-F160 QuadRunner	'91-'01	-	-	-	YB9A-A		YFM35FG Grizzly	'07-'14	-	YTX14AH-BS	-	-	
90	LT-Z90 QuadSport	'07-'09	-	-	YTX7A-BS	-		YFM35R Raptor	'04-'13	-	YTZ10S	-	-	
	LT-Z90 QuadSport	'14-'18	-	-	YTX7A-BS	-		YFM35U Big Bear	'87-'99	-	YTX14AH-BS	-	YB14A-A1	
80	LT80 QuadSport 80	'87-'06	-	YTZ7S	YTX5L-BS	-		YFM35X Warrior	'87-'04	-	-	-	YB12C-A	
50	LT-Z50 QuadSport	'06-'11	-	YTZ7S	YTX5L-BS	-		YFP35 TerraPro	'88	-	YTX14AH-BS	-	YB14A-A1	
	<b>YAMAHA</b>							300	Grizzly 300 Automatic	'12-'13	-	-	YTX12-BS	-
	YFM7FG Grizzly	'07-'13	GYZ20HL	YTX20HL-BS	YTX20L-BS	-	250	YFB250, F Timber Wolf	'92-'00	-	-	-	YB12C-A	
	YFM700DE, DH, PE, PF, PH, PS Grizzly	'14-'15	GYZ20HL	YTX20HL-BS	YTX20L-BS	-		YFM25 Bear Tracker	'99-'04	-	YTX14AH-BS	-	YB14A-A2	
	YFM70 Grizzly	'16-'20	GYZ20HL	YTX20HL-BS	YTX20L-BS	-		YFM250 Moto 4	'89-'91	-	YTX14AH-BS	-	YB14A-A1	
	Raptor 700, R, R SE	'06-'20	-	-	YT9B-BS	-		YFM25B Big Bear	'07-'09	-	YTX14AH-BS	-	YB14A-A2	
	Kodiak 700, EPS	'16-'20	GYZ20HL	YTX20HL-BS	YTX20L-BS	-		YFM25B Bruin	'05-'06	-	YTX14AH-BS	-	YB14A-A2	
660	YFM660FP, FR, FH, FL Grizzly	'02-'04	GYZ20HL	YTX20HL-BS	YTX20L-BS	-	230	YFU-1/T Pro-Hauler	'89	-	YTX14AH-BS	-	YB14A-A1	
	YFM66FA, FG Grizzly	'05-'08	GYZ20HL	YTX20HL-BS	YTX20L-BS	-	225	YFM225 Moto 4	'86-'88	-	YTX14AH-BS	-	YB14A-A1	
	YFM660RN, RT, RP, RR, RL, RS Raptor	'01-'05	GYZ16H	YTX14H-BS	YTX14L-BS	-		YTM225DR, DX Tri-Moto	'83-'86	-	YTX14AH-BS	-	YB14A-A1	
600	YFM600FW, FH Grizzly	'98-'01	GYZ20HL	YTX20HL-BS	YTX20L-BS	-	200	YFM200, DX Moto 4	'85-'89	-	YTX14AH-BS	-	YB14A-A1	
	YFV600FW Grizzly	'98-'01	GYZ20HL	YTX20HL-BS	YTX20L-BS	-		YTM200, E, ER Tri Moto	'83-'85	-	YTX14AH-BS	-	YB14A-A1	
550	YMF5FG, YFM550PE, DE, DH Grizzly	'09-'14	GYZ20HL	YTX20HL-BS	YTX20L-BS	-	125	YFA-1 Breeze	'89-'04	-	-	-	YB12C-A	
450	YFM45FG Grizzly	'07-'14	GYZ20HL	YTX20HL-BS	YTX20L-BS	-		YFM125S, Grizzly	'04-'13	-	-	-	YB12C-A	
	YFM45FX Wolverine	'06-'10	GYZ20HL	YTX20HL-BS	YTX20L-BS	-		YFM125R, Raptor	'11-'13	-	YTZ7S	YTX5L-BS	-	
	YFM450FA, YFM45FA Kodiak	'03-'06	GYZ20HL	YTX20HL-BS	YTX20L-BS	-	100	YFM100 Champ	'87-'90	-	-	-	12N7-3B	
	YFM45KD, KP Kodiak	'18-'20	GYZ20HL	YTX20HL-BS	YTX20L-BS	-		YFM100 Champ	'91	-	-	-	12N7D-3D	
	YFZ450	'04-'13	-	-	YT7B-BS	-	90	YFM90R Raptor	'09-'18	-	YTZ7S	YTX5L-BS	-	
	YFZ450	'17	-	YTZ7S	YTX5L-BS	-	80	YFM80 Badger	'85-'01	-	-	-	12N7-3B	
	YFZ450X	'08	-	-	YT7B-BS	-		YFM80 Grizzly	'05-'08	-	-	-	12N7-3B	
	YFZ450X	'10-'11	-	YTZ7S	YTX5L-BS	-		YFM80R Raptor	'02-'08	-	-	-	12N7-3B	
	YFZ450R	'09-'20	-	YTZ7S	-	-	50	YFM50 Raptor	'04-'08	-	-	-	12N7-3B	
400	YFM40FB Big Bear	'00-'12	GYZ20HL	YTX20HL-BS	YTX20L-BS	-		YFZ50	'17-'19	-	YTZ7S	YTX5L-BS	-	
	YFM40FG Grizzly	'07-'08	-	YTX14AH-BS	-	-								

# PWC (PERSONAL WATERCRAFT) APPLICATIONS

CC	Model	Year	GYZ Series AGM	High Performance AGM	AGM	Yumicron / Conventional	CC	Model	Year	GYZ Series AGM	High Performance AGM	AGM	Yumicron / Conventional
	<b>AQUA-JET CO.</b>							<b>HONDA</b>					
430	Aqua-Jet Sx1	'91	-	-	-	YB16-B	1470	AquaTrax F-15, F-15X	'03-'13	GYZ20HL	YTX20HL-BS	YTX20L-BS	-
432	Aqua-Jet Sx1	'89-'90	-	-	-	YB16-B	1235	AquaTrax F/R-12, F/R-12X	'02-'09	GYZ20HL	YTX20HL-BS	YTX20L-BS	-
	<b>ARCTIC CAT</b>							<b>KAWASAKI (JET SKI)</b>					
770	Tiger Shark	'97-'99	-	YTX14AHL-BS	-	YB14L-A2	1500	JT1500-A, STX, STX-15F	'04-'19	GYZ20HL	YTX20HL-BS	YTX20L-BS	-
640	Tiger Shark	'97-'99	-	YTX14AHL-BS	-	YB14L-A2		JT1500-B, C, 250X, Ultra LX, 260(LX), 300(LX)	'07-'20	GYZ20HL	YTX20HL-BS	YTX20L-BS	-
	Tiger Shark	'93-'96	-	-	-	YB16C-B		SXR	'17-'20	GYZ20HL	YTX20HL-BS	YTX20L-BS	-
	<b>BRP (SEA-DOO)</b>							Ultra 310, LX, R, X					
1630	Fish Pro	'19-'20	GYZ20HL	YTX20HL	YTX20L	-	1200	JH1200-A, B Ultra 150	'99-'05	GYZ20HL	YTX20HL-BS	YTX20L-BS	-
	GTI, GTR, GTX, RXP, RXT, WAKE	'20	GYZ20HL	YTX20HL	YTX20L	-		JT1200-A, B, C, STX-R, STX-12F	'02-'07	GYZ20HL	YTX20HL-BS	YTX20L-BS	-
1500	GTI, GTR, GTS, GTX, RXT, RXP, WAKE	'16-'19	GYZ20HL	YTX20HL-BS	YTX20L-BS	-	1100	JH1100 Zxi	'96-'03	GYZ20HL	YTX20HL-BS	YTX20L-BS	-
	GTI, GTX, GTR RXP, RXT, WAKE	'15	-	YIX30L-PW	-	YB30CL-B		JH1100-B Ultra 130	'01-'04	GYZ20HL	YTX20HL-BS	YTX20L-BS	-
	GTX 4-Tec, RXP	'03-'07	-	YIX30L-PW	-	YB30CL-B		JT1100 STX	'97-'03	GYZ20HL	YTX20HL-BS	YTX20L-BS	-
	All Models	'88-'93	-	YTX20HL-BS	YTX20L-BS	YB16L-B	900	JH900 Zxi	'95-'97	GYZ20HL	YTX20HL-BS	YTX20L-BS	-
	All Other Models	'94-'07	-	YTX20HL-PW	-	YB16CL-B		JT900 STS, STX	'97-'05	GYZ20HL	YTX20HL-BS	YTX20L-BS	-
900	SPARK	'14-'20	GYZ20HL	YTX20HL-BS	YTX20L-BS	-	800	JS800 SX-R	'03-'13	GYZ20HL	YTX20HL-BS	YTX20L-BS	-
	GT190	'18-'20	GYZ20HL	YTX20HL-BS	YTX20L-BS	-	750	JH750 B1-b3	'93-'95	-	YTX20HL-PW	-	YB16CL-B
780	3D	'07	-	YTX20HL-BS-PW	-	YB16CL-B		JH750 E1, F2, G1, G2	'95-'99	GYZ20HL	YTX20HL-BS	YTX20L-BS	-
								JH750 SS, ST, Xi, XiR	'92-'99	-	YTX20HL-PW	-	YB16CL-B
								JH750 ST, Zxi	'95-'97	GYZ20HL	YTX20HL-BS	YTX20L-BS	-
								JH750 SX, ZX	'92-'95	-	YTX20HL-PW	-	YB16CL-B



# PWC (PERSONAL WATERCRAFT) APPLICATIONS

CC	Model	Year	GYZ Series AGM	High Performance AGM	AGM	Yumicron / Conventional	CC	Model	Year	GYZ Series AGM	High Performance AGM	AGM	Yumicron / Conventional
	JS750 SX, ZX	'92-'95	—	YTX20HL-PW	—	YB16CL-B	<b>ULTRANAUTICS</b>						
	JS750 SXi, SXi Pro	'95-'02	GYZ20HL	YTX20HL-BS	YTX20L-BS	—	1250	Jet Star1250 (Boat)	'88-'90	—	—	—	53030
	JT750 STS, STX	'96-'98	GYZ20HL	YTX20HL-BS	YTX20L-BS	—		Jet Star1260 (Boat)	'91	—	—	—	53030
650	JF650 TS	'89-'96	—	YTX20HL-PW	—	YB16CL-B	800	All Models	'87-'92	—	—	—	53030
	JF650 X2	'86-'95	—	YTX20HL-PW	—	YB16CL-B		Wet Bike	'85-'86	—	—	—	YHD-12H
	JL650 SC	'91-'95	—	YTX20HL-PW	—	YB16CL-B	<b>WET JET INTERNATIONAL</b>						
	JS650 SX	'87-'95	—	YTX20HL-PW	—	YB16CL-B	All	All Models	All	GYZ20H	YTX20H-BS	YTX20-BS	—
550	JS550	'82-'85	GYZ20HL	YTX20HL-BS	YTX20L-BS	YB16L-B	<b>YAMAHA</b>						
	JS550, SX	'86-'95	—	YTX20HL-PW	—	YB16CL-B	All	All Wave Runner Models	'87-'08	—	YTX20HL-PW	—	YB16CL-B
440	JS440	'87-'92	—	YTX20HL-PW	—	YB16CL-B	1800	FX, FZR, FZS, VXS, VXR	'09-'20	—	YTX20HL-PW	—	YB16CL-B
	JS440	'77-'86	GYZ20HL	YTX20HL-BS	YTX20L-BS	YB16L-B	1100	VX, V1	'09-'19	—	YTX20HL-PW	—	YB16CL-B
400	JS400	'76	GYZ20HL	YTX20HL-BS	YTX20L-BS	YB16L-B	1049	EX	'17-'19	—	YTX20HL-PW	—	YB16CL-B
300	JS300 TS, SX	'86-'91	—	YTX20HL-PW	—	YB16CL-B	700	Superjet	'09-'17	—	YTX20HL-PW	—	YB16CL-B

## POLARIS

All	All Models	All	—	YTX20HL-PW	—	YB16CL-B
-----	------------	-----	---	------------	---	----------

## S.O.S. MARINE MFG

All	All Models	All	GYZ20H	YTX20H-BS	YTX20-BS	—
-----	------------	-----	--------	-----------	----------	---

# SNOWMOBILE APPLICATIONS

CC	Model	Year	GYZ Series AGM	High Performance AGM	AGM	Yumicron / Conventional	CC	Model	Year	GYZ Series AGM	High Performance AGM	AGM	Yumicron / Conventional
<b>ARCTIC CAT</b>								El Tigre 5000	'87-'88	—	YTX14AHL-BS	—	YB14-A2
1100	Z1, T21, F1100, M1100, Bearcat Z1	'01-'14	GYZ20H	YTX20H-BS	YTX20-BS	—	EXT	'95-'97	—	—	—	—	YB7-A*
	ZR 7000, ZR 9000	'14-'20	GYZ20H	YTX20H-BS	YTX20-BS	—	EXT	'92-'94	—	YTX14AHL-BS	—	—	SYB14L-A2†
	XF1100, T1100, ZR 5000	'14-'17	GYZ20H	YTX20H-BS	YTX20-BS	—	El Tigre, EXT	'89-'91	GYZ20HL	YTX20HL-BS	YTX20L-BS	YB16L-B	—
	XF 7000, 8000, 9000	'14-'19	GYZ20H	YTX20H-BS	YTX20-BS	—	EXT (Powder Special)	'95-'96	GYZ20H	YTX20H-BS	YTX20-BS	YB18-A	—
	M 8000, 9000	'14-'19	GYZ20H	YTX20H-BS	YTX20-BS	—	EXT (EF)	'98	GYZ20H	YTX20H-BS	YTX20-BS	YB18-A	—
	M 7000	'15-'19	GYZ20H	YTX20H-BS	YTX20-BS	—	EXT (EF)	'95-'97	—	—	—	—	YB7-A*
	Pantera 7000	'15-'19	GYZ20H	YTX20H-BS	YTX20-BS	—	EXT (EF)	'94	GYZ20H	YTX20H-BS	YTX20-BS	YB18-A	—
	Bearcat 7000	'15-'19	GYZ20H	YTX20H-BS	YTX20-BS	—	EXT 600	'97-'98	GYZ20H	YTX20H-BS	YTX20-BS	YB18-A	—
	Bearcat 5000	'15-'17	GYZ20H	YTX20H-BS	YTX20-BS	—	EXT Dix (EF)	'97-'98	—	YTX24HL-BS	—	—	Y50-N18L-A-CX
800	F8 LXR, F800, M800, XF800	'07-'13	GYZ20H	YTX20H-BS	YTX20-BS	—	EXT Special	'91-'92	—	YTX14AHL-BS	—	—	YB14L-A2
	ZR 8000	'14-'20	GYZ20H	YTX20H-BS	YTX20-BS	—	F6, F8, F1000	'07-'09	GYZ20H	YTX20H-BS	YTX20-BS	—	—
	Norseman 8000	'19	GYZ20H	YTX20H-BS	YTX20-BS	—	F5	'07-'09	GYZ20H	YTX20H-BS	YTX20-BS	YB18-A	—
	Riot 8000	'20	GYZ20H	YTX20H-BS	YTX20-BS	—	Firecat	'03-'06	—	YTX24HL-BS	—	—	Y50-N18L-A-CX
700	Bearcat 3000, Pantera 3000	'16-'19	GYZ20H	YTX20H-BS	YTX20-BS	—	Jag AFS	'89-'91	—	YTX14AHL-BS	—	—	SYB14L-A2†
	ZR 3000, Norseman 3000	'17-'19	GYZ20H	YTX20H-BS	YTX20-BS	—	Jag AFS L/T	'89-'93	—	YTX14AHL-BS	—	—	SYB14L-A2†
600	ZR 6000	'14-'20	GYZ20H	YTX20H-BS	YTX20-BS	—	Jag Liquid	'96	—	YTX14AHL-BS	—	—	YB14-A2
	M 6000	'15-'19	GYZ20H	YTX20H-BS	YTX20-BS	—	Jag Z	'94	—	YTX14AHL-BS	—	—	YB14-A2
	XF 6000	'17-'18	GYZ20H	YTX20H-BS	YTX20-BS	—	Jag Z	'93	—	YTX14AHL-BS	—	—	SYB14L-A2†
	Norseman 6000	'18-'19	GYZ20H	YTX20H-BS	YTX20-BS	—	Jag, Jag Dlx	'94-'99	—	YTX14AHL-BS	—	—	YB14-A2
	Riot 6000	'20	GYZ20H	YTX20H-BS	YTX20-BS	—	Jag, Jag Dlx	'85-'93	—	YTX14AHL-BS	—	—	SYB14L-A2†
570	F570, T570, Bearcat	'08-'14	GYZ20H	YTX20H-BS	YTX20-BS	YB18-A	Jaguar	'07	GYZ20H	YTX20H-BS	YTX20-BS	—	—
565	Lynx 2000	'15-'20	GYZ20H	YTX20H-BS	YTX20-BS	—	King Cat 900	'04-'06	—	YTX24HL-BS	—	—	Y50-N18L-A-CX
	Bearcat 2000	'17-'20	GYZ20H	YTX20H-BS	YTX20-BS	—	Lynx	'91-'93	—	YTX14AHL-BS	—	—	SYB14L-A2†
500	F5 LXR	'07-'14	GYZ20H	YTX20H-BS	YTX20-BS	YB18-A	M 5	'05-'06	GYZ20H	YTX20H-BS	YTX20-BS	—	—
	4 Stroke Trail, Touring	'02-'03	—	YTX24HL-BS	—	Y50-N18L-A-CX	M 6	'05-'07	GYZ20H	YTX20H-BS	YTX20-BS	—	—
	Bearcat 340, 440	'95-'00	—	YTX14AHL-BS	—	YB14-A2	M 7	'05-'06	GYZ20H	YTX20H-BS	YTX20-BS	—	—
	Bearcat 570	'04-'08	—	YTX24HL-BS	—	Y50-N18L-A-CX	Mountain Cat	'01	GYZ20H	YTX20H-BS	YTX20-BS	YB18-A	—
	Bearcat 570	'09-'14	GYZ20H	YTX20H-BS	YTX20-BS	—	Mountain Cat 500	'02	GYZ20H	YTX20H-BS	YTX20-BS	YB18-A	—
	Bearcat WT Turbo	'06-'08	—	YTX24HL-BS	—	—	Mountain Cat 570	'02-'04	—	YTX24HL-BS	—	—	Y50-N18L-A-CX
	Bearcat WT	'05-'08	—	YTX24HL-BS	—	—	Mountain Cat 600	'02-'04	GYZ20H	YTX20H-BS	YTX20-BS	YB18-A	—
	Bearcat WT	'03-'04	—	YTX24HL-BS	—	—	Mountain Cat 800	'02-'04	—	YTX24HL-BS	—	—	Y50-N18L-A-CX
	Bearcat WT	'95-'02	GYZ20H	YTX20H-BS	YTX20-BS	YB18-A	Mountain Cat 900	'03-'04	—	YTX24HL-BS	—	—	Y50-N18L-A-CX
	Cheetah 340, 550	'94	—	YTX14AHL-BS	—	YB14-A2	Mountain Cat 1000	'02	GYZ20H	YTX20H-BS	YTX20-BS	YB18-A	—
	Cheetah 440 1-Speed, 2-Speed	'94	—	YTX14AHL-BS	—	SYB14L-A2†	Pantera 1000	'01-'02	GYZ20H	YTX20H-BS	YTX20-BS	YB18-A	—
	Cheetah	'91-'93	—	YTX14AHL-BS	—	SYB14L-A2†	Pantera 580	'99-'01	GYZ20H	YTX20H-BS	YTX20-BS	YB18-A	—
	Cheetah	'89-'90	GYZ20HL	YTX20HL-BS	YTX20L-BS	YB16L-B	Pantera, 580	'95-'98	—	YTX24HL-BS	—	—	Y50-N18L-A-CX
	Cougar	'95-'98	GYZ20H	YTX20H-BS	YTX20-BS	YB18-A	Pantera	'94	GYZ20H	YTX20H-BS	YTX20-BS	—	—
	Cougar	'91-'94	—	YTX14AHL-BS	—	SYB14L-A2†	Pantera	'86-'93	—	YTX14AHL-BS	—	—	SYB14L-A2†
	Cougar	'89-'90	GYZ20HL	YTX20HL-BS	YTX20L-BS	YB16L-B	Pantera	'80-'85	—	—	—	—	YB16L-B
	Crossfire 500	'07	GYZ20H	YTX20H-BS	YTX20-BS	—	Pantera 550, 600	'02-'05	GYZ20H	YTX20H-BS	YTX20-BS	YB18-A	—
	Crossfire 600	'06-'07	GYZ20H	YTX20H-BS	YTX20-BS	—	Pantera 800	'02-'04	—	YTX24HL-BS	—	—	Y50-N18L-A-CX
	Crossfire 700	'06	GYZ20H	YTX20H-BS	YTX20-BS	—	Panther	'94-'96	—	YTX14AHL-BS	—	—	YB14-A2
							Panther	'89-'93	—	YTX14AHL-BS	—	—	SYB14L-A2†
							Panther	'80-'88	—	—	—	—	YB16L-B

\* See Battery Cross Reference Chart on page 17  
† This battery includes a sensor

■ Top and front terminal mounts only



# SNOWMOBILE APPLICATIONS

CC	Model	Year	GYZ Series AGM	High Performance AGM	AGM	Yumicron / Conventional
	Panther 340	'98-'00	-	YTX14AH-BS	-	YB14-A2
	Panther 370	'01-'08	-	YTX14AH-BS	-	YB14-A2
	Panther 440	'97-'02	-	YTX14AH-BS	-	YB14-A2
	Panther 550	'97-'01	GYZ20H	YTX20H-BS	YTX20-BS	YB18-A
	Panther 570	'02-'07	-	YTX24HL-BS*	-	Y50-N18L-A-CX
	Panther 660	'06-'08	-	YTX24HL-BS*	-	Y50-N18L-A-CX
	Powder Extreme	'97-'98	GYZ20H	YTX20H-BS	YTX20-BS	YB18-A
	Powder Special	'95-'97	GYZ20H	YTX20H-BS	YTX20-BS	YB18-A
	Prowler, 2-up (w/o electric start)	'94	-	-	-	YB7-A*
	Prowler, 2-up (with electric start)	'94	GYZ20H	YTX20H-BS	YTX20-BS	YB18-A
	Prowler	'90-'93	-	YTX14AHL-BS	-	YB14L-A2
	Prowler 2-Up	'91-'93	-	YTX14AHL-BS	-	YB14L-A2
	Prowler 2-Up	'95	GYZ20H	YTX20H-BS	YTX20-BS	YB18-A
	Prowler Special	'91-'92	GYZ20H	YTX20H-BS	YTX20-BS	YB18-A
	Puma, 2-Up, Deluxe	'94-'97	-	YTX14AH-BS	-	YB14-A2
	Sabercat 500 LX	'04-'05	GYZ20H	YTX20H-BS	YTX20-BS	YB18-A
	Sabercat 500, 600, 700	'04-'06	-	YTX24HL-BS*	-	Y50-N18L-A-CX
	T660 Touring	'04-'08	-	YTX24HL-BS*	-	Y50-N18L-A-CX
	T660 Turbo Touring	'04-'07	-	YTX24HL-BS	-	-
	Thundercat	'97-'02	GYZ20H	YTX20H-BS	YTX20-BS	YB18-A
	Wildcat (EFI)	'95-'96	-	-	-	YB7-A*
	Wildcat (EFI)	'93	-	YTX14AHL-BS	-	SYB14L-A2†
	Wildcat MC	'94-'96	-	-	-	YB7-A*
	Wildcat Touring	'95-'96	-	-	-	YB7-A*
	Z 440	'98-'06	-	YTX14AH-BS	-	YB14-A2
	Z 370	'99-'07	-	YTX14AH-BS	-	YB14-A2
	Z 570	'02-'07	-	YTX24HL-BS*	-	Y50-N18L-A-CX
	ZL 500	'01-'02	GYZ20H	YTX20H-BS	YTX20-BS	YB18-A
	ZL 550, 600	'01-'03	GYZ20H	YTX20H-BS	YTX20-BS	YB18-A
	ZL 800	'01	GYZ20H	YTX20H-BS	YTX20-BS	YB18-A
	ZL 800	'02-'03	-	YTX24HL-BS*	-	Y50-N18L-A-CX
	ZR 580 (EFI)	'95-'96	-	-	-	YB7-A*
	ZR 500, 600	'01-'02	GYZ20H	YTX20H-BS	YTX20-BS	YB18-A
	ZR 800	'02-'03	-	YTX24HL-BS*	-	Y50-N18L-A-CX
	ZR 900	'03-'06	-	YTX24HL-BS*	-	Y50-N18L-A-CX
	ZRT 600, 800	'97-'02	GYZ20H	YTX20H-BS	YTX20-BS	YB18-A
200	ZR 200	'18-'19	-	-	YTX7L-BS	-

CC	Model	Year	GYZ Series AGM	High Performance AGM	AGM	Yumicron / Conventional
<b>KAWASAKI</b>						
	All Models	All	-	YTX24HL-BS*	-	Y50-N18L-A-CX
<b>POLARIS</b>						
	All EFI (RXL, 500 EFI)	'93-'97	-	-	-	YB9A-A
	All Electric Start Kits	'85-'93	-	YTX24HL-BS*	-	Y50-N18L-A-CX
	All Electric Start Kits	'94-'05	-	YTX14AH-BS	-	YB14A-A2
	All Other Models	'92-'05	-	YTX14AH-BS	-	YB14A-A2
	Indy, Indy Trail	'84-'91	-	YTX24HL-BS*	-	Y50-N18L-A-CX
	Sprint (Electric Start)	'86-'90	-	-	-	Y60-N24-A
850	Rush Pro, SKS	'19	-	YTX20CH-BS	-	-
	Switchback	'19-'20	-	YTX20CH-BS	-	-
800	Switchback, RMK	'10	GYZ20HL	YTX20HL-BS	YTX20L-BS	-
	Rush, Switchback, RMK	'11-'20	-	YTX20CH FA	-	-
	Indy	'14-'16	-	YTX20CH FA	-	-
	SKS	'16	-	YTX20CH FA	-	-
	Titan SP, Adventure/XC	'18-'20	-	YTX20CH FA	-	-
750	FS/ST, Wide Trak	'06-'10	GYZ20HL	YTX20HL-BS	YTX20L-BS	-
	Turbo Switchback, Turbo Dragon	'06-'10	GYZ20HL	YTX20HL-BS	YTX20L-BS	-
	Turbo LX, IQ	'08-'14	GYZ20HL	YTX20HL-BS	YTX20L-BS	-
	FS Wide Trak	'10-'13	GYZ32HL	YTX30L-BS	-	YB30L-B
600	IQ Touring	'08	-	YTX14AH-BS	-	-
	IQ, Shift, Switchback, RMK	'09-'11	GYZ20HL	YTX20HL-BS	YTX20L-BS	-
	Shift, Switchback, RMK	'09-'10	GYZ20HL	YTX20HL-BS	YTX20L-BS	-
	Wide Trak	'10-'17	GYZ32HL	YTX30L-BS	-	YB30L-B
	Rush	'10-'19	-	YTX20CH FA	-	-
	Switchback, RMK	'12-'19	-	YTX20CH-BS	-	-
	Indy, Voyageur	'14-'20	-	YTX20CH-BS	-	-
	Wide Trak	'14-'17	GYZ32HL	YTX30L-BS	-	YB30L-B
550	IQ, LXT, Shift	'13	GYZ20HL	YTX20HL-BS	YTX20L-BS	-
	Indy, Voyageur, Adventure	'14-'20	-	YTX20CH-BS	-	-
	Wide Trak	'16-'19	-	YTX20CH-BS	-	-
544	Trail, Trail Touring	'09	-	YTX14AH-BS	-	YB14A-A2
500	Wide Trak	'89-'14	-	YTX24HL-BS*	-	Y50-N18L-A-CX

## YAMAHA

1049	FX Nyro	'08-'14	GYZ20HL	YTX20HL-BS	YTX20L-BS	-
	RS Venture	'09-'20	GYZ20HL	YTX20HL-BS	YTX20L-BS	-
	RS Vector (All Models)	'10-'18	GYZ20HL	YTX20HL-BS	YTX20L-BS	-
	SR VIPER L/M/R/S/X	'14-'19	GYZ20H	YTX20H-BS	YTX20-BS	-
	VK Professional II	'16-'20	GYZ20HL	YTX20HL-BS	YTX20L-BS	-
1000	Apex	'06-'18	GYZ16H	YTX14H-BS	YTX14-BS	-
	Attak, GT	'06-'07	GYZ16H	YTX14H-BS	YTX14-BS	-
	RS1000S, GT, RS	'06-'14	GYZ20HL	YTX20HL-BS	YTX20L-BS	-
	RX1000R RX (All Models)	'03-'05	GYZ20HL	YTX20HL-BS	YTX20L-BS	-
	Sidewinder (All Models)	'17-'19	GYZ20H	YTX20H-BS	-	-
973	(RS) Vector all models	'05-'09	GYZ20HL	YTX20HL-BS	YTX20L-BS	-
	RS Viking Professional, VK Pro	'06-'15	GYZ20HL	YTX20HL-BS	YTX20L-BS	-
	RS Venture	'05-'08	GYZ20HL	YTX20HL-BS	YTX20L-BS	-
	Nyro	'06-'07	GYZ20HL	YTX20HL-BS	YTX20L-BS	-
700	SKV700ER SKViper ER	'02-'05	-	YTX24HL-BS*	-	Y50-N18L-A-CX
	VT700 Venture 700	'98-'04	-	YTX24HL-BS*	-	Y50-N18L-A-CX
	VX700DX Vmax 700 Deluxe	'99-'00	-	YTX24HL-BS*	-	Y50-N18L-A-CX
	VX700ER Vmax 700 ER	'01-'02	-	YTX24HL-BS*	-	Y50-N18L-A-CX
	VX700XTDX Vmax 700 XTC Deluxe	'98	-	YTX24HL-BS*	-	Y50-N18L-A-CX
600	VT600 Venture 600	'97-'98	-	-	-	YB16AL-A2
	VT600 Venture 600	'99-'06	-	YTX24HL-BS*	-	Y50-N18L-A-CX
	VX600DX Vmax 600 Deluxe	'99-'01	-	YTX24HL-BS*	-	Y50-N18L-A-CX
	VX600E/DX Vmax 600 LE/DX	'94-'96	-	-	-	YB16AL-A2
	VX600ER Vmax 600 ER	'02-'03	-	YTX24HL-BS*	-	Y50-N18L-A-CX
	VX600XTC Vmax 600 XTC	'97-'98	-	-	-	YB16AL-A2
570	EX570E Exciter, II LE, Deluxe	'88-'93	-	-	-	YB16AL-A2
540	EC540 Excel	'79-'80	-	YTX24HL-BS*	-	Y50-N18L-A-CX
	VK540E, M, II, III	'88-'05	-	-	-	YB16AL-A2
	VK540	'18-'20	-	-	-	YB16AL-A2
	XL540 XLV	'85-'90	-	-	-	YB16AL-A2
500	Phazer All Models	'07-'18	GYZ16H	YTX14H-BS	YTX14-BS	-
	Venture Lite, MP, RS	'07-'18	GYZ16H	YTX14H-BS	YTX14-BS	-
	PZ500DX Phazer 500 Deluxe	'01	-	-	-	YB16AL-A2
	VT500 Venture 500	'97-'01	-	-	-	YB16AL-A2
	VT500 Venture 500 XL	'99-'00	-	-	-	YB16AL-A2
	VX500E, F, DX, ST Vmax	'94-'01	-	-	-	YB16AL-A2
480	PZ480E Phazer Deluxe	'84-'89	-	YTX14AHL-BS	-	SYB14L-A2†

## BRP (SKI-DOO)

	All 4-stroke	'03	-	YTX24HL-BS	-	-
	All Models	'98	-	YTX24HL-BS*	-	Y50-N18L-A-CX
	CK3 Types	'99-'03	-	YTX24HL-BS*	-	Y50-N18L-A-CX
	Elite	'04-'06	GYZ32HL	YTX30L-BS	-	YB30L-B
	ZX Types	'99-'01	-	-	YTX15L-BS	-
	ZX Types	'02-'03	GYZ20HL	YTX20HL-BS	YTX20L-BS	-
1200	Grand Touring, Expedition	'10-'18	GYZ20HL	YTX20HL FA	YTX20L FA	-
	Expedition SE	'15-'19	GYZ32HL	YTX30L-BS	-	YB30L-B
	Expedition LE	'10-'12	-	YTX20HL-BS-PW	-	-
	Expedition LE	'13-'19	GYZ20HL	YTX20HL-BS	-	-
	Renegade, GSX, MX Z	'09-'18	GYZ20HL	YTX20HL FA	YTX20L FA	-
1000	Expedition, Legend, Skandic	'03-'06	-	YTX24HL FA	-	-
900	Renegade, MX Z, Expedition, Grand Touring, Skandic	'14-'20	GYZ20HL	YTX20HL FA	YTX20L FA	-
850	Renegade X E-TEC, Adventure	'17-'20	GYZ20HL	YTX20HL FA	YTX20L FA	-
	MX Z E-TEC, SUMMIT E-TEC	'17-'20	GYZ20HL	YTX20HL FA	YTX20L FA	-
	Free Ride (All Models)	'18-'20	GYZ20HL	YTX20HL FA	YTX20L FA	-
	Expedition Xtreme	'20	GYZ32HL	YTX30L-BS	-	-
	Backcountry	'19-'20	GYZ20HL	YTX20HL FA	YTX20L FA	-
800	Expedition	'07-'19	GYZ20HL	YTX20HL FA	YTX20L FA	-
	Renegade, Summit, Free Ride	'04-'19	GYZ20HL	YTX20HL FA	YTX20L FA	-
	GSX, MX Z	'04-'17	GYZ20HL	YTX20HL FA	YTX20L FA	-
600	Expedition, Skandic, Summit, Sport	'06-'20	GYZ20HL	YTX20HL FA	YTX20L FA	-
	Expedition SE	'13-'20	GYZ32HL	YTX30L-BS	-	-
	Expedition SE	'10-'12	GYZ32HL	YTX30L FA	-	-
	Skandic ACE	'15-'18	GYZ32HL	YTX30L-BS	-	-
	Skandic ACE	'19-'20	GYZ20HL	YTX20HL-BS	-	-
	Grand Touring, Renegade	'04-'20	GYZ20HL	YTX20HL FA	YTX20L FA	-
	Tundra, MX Z, GSX	'04-'20	GYZ20HL	YTX20HL FA	YTX20L FA	-
	Backcountry	'19-'20	GYZ20HL	YTX20HL FA	YTX20L FA	-
550	Expedition, Skandic, Tundra, Sport	'05-'20	GYZ20HL	YTX20HL FA	YTX20L FA	-
	Grand Touring, Renegade	'14	GYZ20HL	YTX20HL FA	YTX20L FA	-
	MX Z, GSX, GTX	'07-'14	GYZ20HL	YTX20HL FA	YTX20L FA	-
300	Skandic Tundra	'07-'09	GYZ20HL	YTX20HL-BS	YTX20L-BS	-

\* See Battery Cross Reference Chart on page 17

† This battery includes a sensor

FA Must use Factory Activated battery

\* Top and front terminal mounts only

# SNOWMOBILE APPLICATIONS

CC	Model	Year	GYZ Series AGM	High Performance AGM	AGM	Yumicron / Conventional	CC	Model	Year	GYZ Series AGM	High Performance AGM	AGM	Yumicron / Conventional
	PZ480E Phazer II LE, SS	'90-'98	—	YTX14AHL-BS	—	SYB14L-A2 †		ET340E Enticer	'79	—	YTX24HL-BS *	—	Y50-N18L-A-CX
	VT480 Venture GT	'92-'93	—	YTX14AHL-BS	—	SYB14L-A2 †		ET340E Enticer	'80	—	YTX14AHL-BS	—	SYB14L-A2 †
	VT480 Venture XL	'91-'97	—	YTX14AHL-BS	—	SYB14L-A2 †	300	CF300 Inviter	'86-'90	—	—	—	YB16AL-A2
	VT480TR Venture TR Electric	'98	—	YTX14AHL-BS	—	SYB14L-A2 †	200	SXR2 Sno-Scoot	'19	—	—	YTX7L-BS	—
340	CS340 Ovation Deluxe/LE	'89-'00	—	YTX14AHL-BS	—	SYB14L-A2 †	125	SV125E Sno-Sport	'90-'91	—	YTX14AHL-BS	—	SYB14L-A2 †
	EC340 Excel III	'81-'88	—	YTX14AHL-BS	—	SYB14L-A2 †	80	SV80E Sno-Scoot	'88-'90	—	—	—	YB7L-B*

\* See Battery Cross Reference Chart on page 17  
 ■ Top and front terminal mounts only

† This battery includes a sensor

## 1 AMP Automatic Battery Charger & Maintainer

Part No. YUA1AMPCH

- 3 stage charge cycle
- Automatically switches to maintenance mode when battery is fully charged
- Designed to prevent overcharging
- Includes 12 ft. total cable length, quick connect adapter and alligator clips
- 5 year limited warranty



## 2 AMP Dual-bank Automatic Charger & Maintainer

Part No. YUA2AMPCH

- 2 independent charging stations
- Charges 6 & 12 volt batteries
- Automatic charging and maintenance maximizes battery life
- OEM-approved 5-stage charging algorithm saves time and energy
- Active desulfation to recover sulfated batteries
- Defective battery detection to eliminate surprises
- 5 year limited warranty



## 3 AMP Automatic Battery Charger & Maintainer

Part No. YUA3AMPCH

- Automatic charging and maintenance maximizes battery life
- OEM-approved 5-stage charging algorithm saves time and energy
- Active desulfation to recover sulfated batteries
- Defective battery detection to eliminate surprises
- 13 ft. total cable length including alligator clips
- 5 year limited warranty



## Battery Charger Leads

Part No. YUA00ACC04 - 18AWG Wire, 3 amp fuse

Part No. YUA00ACC05 - 16AWG Wire, 15 amp fuse

- Compatible with all Yuasa consumer chargers and maintainers
- Support electrical accessories such as heated gear and GPS units



## Jumper Cables

Part No. YUA00ACC07

- Convenient storage bag included
- Heavy duty, 8 ft., 8-gauge cables won't stiffen or freeze
- Tangle resistant, encased rubber grips for safer use





## Digital Battery Print Tester



Part No. YUA00BTY01P

## EASY, FAST, ACCURATE, AFFORDABLE

- Developed exclusively for powersports batteries
- Determines battery health and charge status in seconds
- Single load, dynamic resistance technology minimizes battery drain during test
- Tests both charged and discharged batteries accurately
- Digital battery tester prints recommended actions
- Charging system check
- 1 year limited warranty

12V

APPLICATION	12V Powersports Batteries 2.3 ~ 32AH
VOLTMETER	1.5V ~ 30V
THERMAL PRINTER	Prints results in seconds
INCLUDED ACCESSORIES	Heavy-duty Plastic Case 2 Rolls of Printer Paper 4 AA Batteries
LANGUAGES	English, French, Spanish, German, Italian, Portuguese
DIMENSION	195 (L) X 114 (W) X 50 (H) (mm)

## TEST FLOW:

BATTERY TEST: ✓  
12.88V

Application:  
12V

BATTERY CATEGORY: ✓  
AGM

Battery Category:  
a. CONVENTIONAL  
b. AGM

SET CAPACITY: ✓  
20AH

GOOD & PASS: ✓  
12.79V

4 Test Results:  
a. Good & Pass  
b. Good & Recharge  
c. Recharge & Retest  
d. Bad & Replace

PRINT RESULTS? ✓  
YES

## Replacement Paper Roll

Part No. YUABTY01PPR

- Thermal printing paper
- 2 rolls of printer paper



## **Small Display Rack**

**Part No. 60052**

- 24" wide x 48" high x 10" deep
- Order header card separately



## **Small Battery Rack Header Card**

**Part No. YUA-SMHC**



## **Large Display Rack**

**Part No. YUASARACK**

- 37" wide x 62" high x 15" deep
- Order header card separately



## **Large Battery Rack Header Card**

**Part No. YUA-LGHC**

**Part No. YUA-LGHCM - Battery Applications**

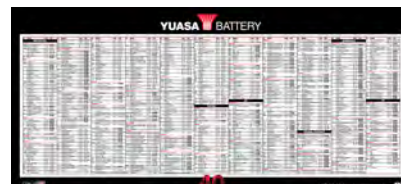

**Metal Sign**  
Part No. YUA-888



**2020 Counter Mat**  
Part No. YUA-016



**3' x 5' Banner**  
Part No. YUA-001



**Counter Stool**  
Part No. YUA-999





Any device that stores energy can be dangerous. There is a lot of explosive power in a gallon of gasoline, but when handled with some knowledge, its use can be made relatively safe. Batteries are no different in that with the proper precautions and safety practices, they can be

handled in a safe manner. Working with batteries poses two hazards: potentially explosive gases that are given off during discharging and charging, and sulfuric acid, which is highly corrosive. The safety chart below will help keep these two hazards under control:

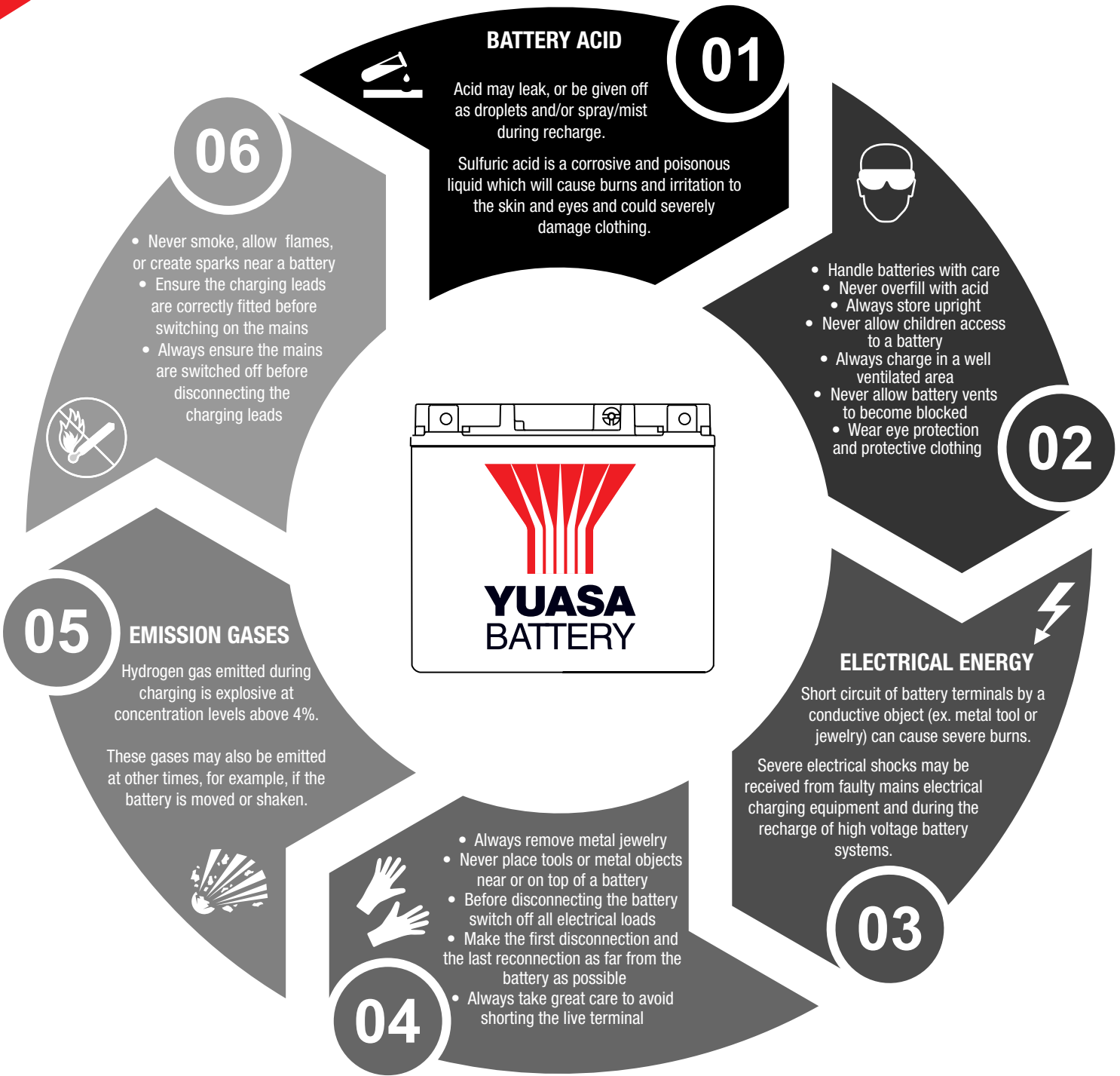

## BATTERY CHARGING

**Chemistry.** During discharge, sulfuric acid is drawn from the electrolyte into the plates. This forms sulfate on the plates. Charging a battery reverses the chemical process that occurred during discharge, sending the sulfate back into the electrolyte as sulfuric acid. The electrical energy used to charge a battery is converted back to chemical energy and stored inside the battery. Battery chargers, including alternators and generators, produce a higher voltage (higher "electrical pressure") than the battery's open circuit voltage. For example, if a battery charger that outputs 14 volts is connected to a 12 volt battery, current flow will be from the charger into the battery. This high electrical pressure, or voltage, is required to push electrical current back into the battery, overcoming its open circuit voltage and thus providing charging current. The charging device (alternator, generator, or battery charger) produces excess electrons at the negative battery plates where positive hydrogen ions are then attracted to them. The hydrogen ions combine with the lead sulfate on the discharged plates to form sulfuric acid and lead, which ultimately reduces the amount of water in the electrolytic solution and increases the battery's specific gravity during the charging process.

### HOW MANY AMPS?

Applying a charging current to a battery, without overheating

it, is called the "*natural absorption rate*". Because of their smaller size, when compared to automotive types of batteries, powersports batteries are more sensitive to how much current they can safely absorb. **When charging a motorcycle or other small battery, the battery charger should not exceed 3 amps.** Most automotive types of battery chargers are not suitable for charging a motorcycle battery because they output current above 3 amps. For the correct charge rate, a rule of thumb is to divide the battery's amp hour rating by 10. For example, a 14 AH battery should be charged at 1.4 amps ( $14\text{AH} / 10 = 1.4$  amps).

When charging amperage exceeds the level of the natural absorption rate, the battery may overheat, causing the electrolyte solution to bubble, creating flammable hydrogen gas. Hydrogen gas, when combined with oxygen from the air, is highly explosive and can easily be ignited by a spark. Consequently, **always remember to turn the power off before connecting or disconnecting a battery charger to prevent a spark at the battery terminals!** Many battery chargers that are designed for use with small batteries have a "*no spark*" feature when being connected or disconnected from the battery. In addition to excessive out-gassing during charging, a battery that has been rapidly discharging (cranking an engine over until it's dead, for instance) may also produce excessive hydrogen gas.

Charging Times						
State of Charge	Battery Types					
	YB14	YB30L	YTX14	YTX20HL	YIX30L	GYZ20L
Approximate Charge Times (Hours) Using a "Trickle" (0.25 Amp) Charger						
75%	18	38	15	23	38	25
50%	35	75	30	45	75	50
25%	53	113	45	68	113	75
0%	70	150	60	90	150	100
Approximate Charge Times (Hours) Using a 1 Amp Taper Charger						
75%	8	17	7	10	17	11
50%	14	30	13	18	30	20
25%	20	42	18	25	42	28
0%	27	56	23	33	56	37
Approximate Charge Times (Hours) Using a 1 Amp Constant Current Charger						
75%	4	9	4	6	9	6
50%	9	19	8	11	19	13
25%	13	28	11	17	28	19
0%	18	38	15	23	38	25

## CHECKING A BATTERY

A routine should be established by which a battery is checked for state-of-charge and charged if necessary. Because access to the battery may be difficult on some vehicles, a permanent, quick connect/disconnect connector can be installed, allowing the battery charger to be connected to the vehicle's battery externally. When charging a battery, always refer to the instructions that come with the battery charger. While maintaining a battery at its full state-of-charge will insure optimum life, overcharging may significantly reduce the battery's life. Any of the Yuasa automatic chargers (1 AMP, 2 AMP and 3 AMP) will maintain both AGM and Conventional battery types without overcharging them. Use the following guidelines for charging AGM and Conventional batteries:

- Always verify battery state-of-charge before charging, and 30 minutes after charging.
- A battery charger has been disconnected from the battery for one to two hours, a fully charged Conventional battery should read 12.6 volts or higher.
- AGM batteries may have slightly higher voltage readings after a full charge.

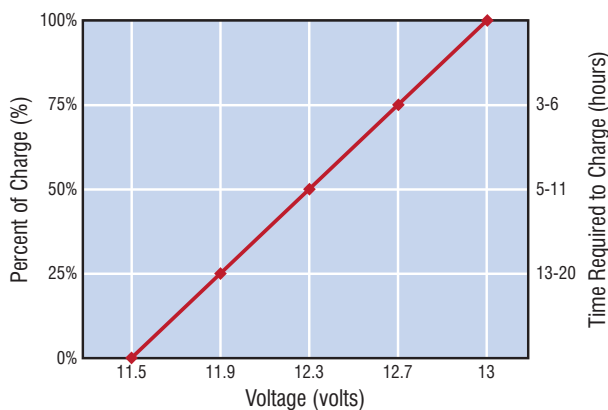

The approximate charging times are shown using a constant current charge (Yuasa charger) at the amps specified on the battery.

**Do not overcharge.** Because of the characteristics of an AGM battery, too much of a boost charge, or overcharging will decrease the volume of electrolyte. The longer the overcharge time, the greater the drop in electrolyte and starting power. The battery is sealed, water can not be added to make up the difference in the loss of electrolyte.

In addition, overcharging can warp cell plates making future charging difficult or impossible. To prevent overcharging, track charging times carefully, or ideally, use one of Yuasa's Automatic Chargers. Always stop charging if the battery case becomes too hot to touch. Let it cool down 6 to 12 hours and resume charging. Charging times will vary depending on charger type and battery size. **Caution:** *Always wear safety glasses when handling batteries and charge them in a well-ventilated area.*

## CHARGING A DEEPLY DISCHARGED BATTERY

Batteries with an open circuit voltage below 11.5 volts may require a special charger and procedures to recharge. Deeply discharged batteries will have high internal resistance, making normal battery charging difficult. It may be necessary to use a charging voltage higher than normal to get the battery to accept a charge. The Yuasa Automatic 12V 4 AMP battery charger is capable of charging at a rate of 20 volts and has two current settings. Whether you use a Yuasa charger or another charger, charge the battery for 30 minutes and then measure the open circuit voltage. If the voltage reading has not increased (indicating that charging has taken place) the battery must be replaced. If the battery is accepting a charge, continue charging. During this process, if the battery's case temperature becomes too high (about 140° F) charging should be stopped or charging current should be reduced. The process of charging a deeply discharged battery may take up to 20 hours or more.

### POINTS TO REMEMBER

- Prolonged discharge causes harmful sulfation and may damage a battery
- Discharged (dead) batteries are prone to freezing in cold temperatures
- Short trips may not provide enough battery charging time
- Always verify the state-of-charge 30 minutes after charging
- Storing batteries in high temperatures will cause damage to the battery
- Never exceed 3 amps when charging a motorcycle, or other small battery



## HOW TO ACTIVATE AN AGM BATTERY

Yuasa AGM batteries leave the factory either FA or BS:

- **Factory Activated (FA)** – the battery is filled with electrolyte, sealed and charged at the factory. These batteries must be used within a period of time and cannot be stored indefinitely.
- **Bottle Supplied (BS)** – dry AGM batteries are shipped with the electrolyte stored in a plastic container. The battery is filled with electrolyte from the container when it's ready to be activated. AGM dry batteries have a shelf life of 5 years from the manufacturer, as long as they remain sealed. Proper seal for AGM batteries means a foil sealing strip in place on the battery without damage or flaw. Once a battery is unsealed it should be activated, charged, and installed. The plates of an unsealed battery will begin to oxidize, making it more difficult to charge later.

Activating an AGM battery (BS) is a simple process and differs from activating a Conventional battery. Non-activated AGM batteries can be stored for long periods of time as long as they are kept in a cool, dry location and out of direct sunlight. Also the foil sealing strip covering the filler ports should not be removed until the battery is ready to be activated. Use only the electrolyte container that comes with the battery for filling the cells as it has a higher concentration of sulfuric acid than the acid used for Conventional batteries.

It's also important to note that not all electrolyte containers are created equal. Typically, each contain has the proper amount of electrolyte for its specific battery. Always read the precautions and instructions on the electrolyte container before handling and filling your AGM battery.

*Do not smoke when activating a battery or handling battery acid. Always wear plastic gloves and protective eye wear.*



The electrolyte container that is shipped with a dry AGM battery contains the correct amount of battery acid and is more concentrated than the electrolyte used in a conventional battery.

## THE 7-STEP PROCESS TO ACTIVATE AN AGM BATTERY:

1. The battery must be out of the vehicle and placed on a level surface.
2. Remove electrolyte container from the plastic storage bag. Remove the strip of caps and set it aside as it will be necessary later in the process. When filling your AGM battery use only the dedicated acid container that comes with the battery as it contains the proper amount of electrolyte for that specific battery. This is important to service life and battery performance. **Do not pierce, or otherwise open the foil seals on the electrolyte container. Do not attempt to separate the individual electrolyte containers.**

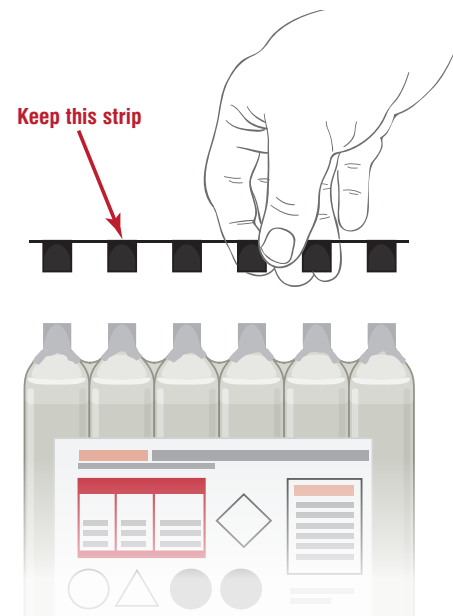

Do not puncture the foil seal or remove it prior to filling a dry AGM battery.

3. Place the electrolyte container with the foil seals facing down into the cell filler ports on the battery. Hold the container level and push down to break the foil seals. Electrolyte will start to flow into the battery and air bubbles will be seen inside the container. **Do not tilt the electrolyte container.**

4. Check the electrolyte flow. **Keep the container in place for 20 minutes or longer until it empties completely.** If no air bubbles are coming up from the filler ports, or if container cells haven't emptied completely after 20 minutes, tap the container gently and/or battery case a few times to cause the electrolyte to flow into the battery. Do not remove the acid container from the battery until it is completely empty. The battery requires the entire electrolyte from the container for proper operation.

Bubbles will appear as the electrolyte container fills the battery indicating the flow of battery acid. Tap the container periodically to keep the electrolyte flowing until the container is completely empty. **Never puncture the top of the acid container to speed up the filling process.**

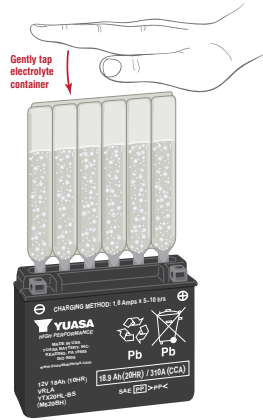

5. Carefully remove the empty electrolyte container from the battery. Fully insert the strip of sealing caps (previously removed from the electrolyte container) into the battery filling ports. Make sure the strip of caps is fully inserted and flush with the top of the battery. Insert the caps by hand, do not use a hammer or excessive force. **Never remove the strip of caps or add water or electrolyte to the battery during its service life.**



After filling, the sealing caps should be installed using hand pressure only. The sealing cap should never be removed once the battery is activated.

6. For batteries with ratings of less than 18 AH, let the battery stand for 20 to 60 minutes. For batteries with higher AH ratings, and/or having the **High Performance rating (designated by an "H" in the part number/name)** allow the battery to stand for 1 to 2 hours. Yuasa AGM batteries have the amp hour (AH) printed on the front of the battery case. The stand, or rest period, allows the electrolyte to permeate into the plates for optimum performance.

7. **Newly activated AGM batteries require an initial charge.** After adding electrolyte, a new battery is approximately 75-80% charged. After the "stand" period (step 6), charge the battery to bring it to a full state-of-charge. The battery charger used for initial charging should be able to charge at 12.8+ volts for an AGM battery. All Yuasa battery chargers are capable of reaching this minimum voltage and initializing/activating an AGM battery.

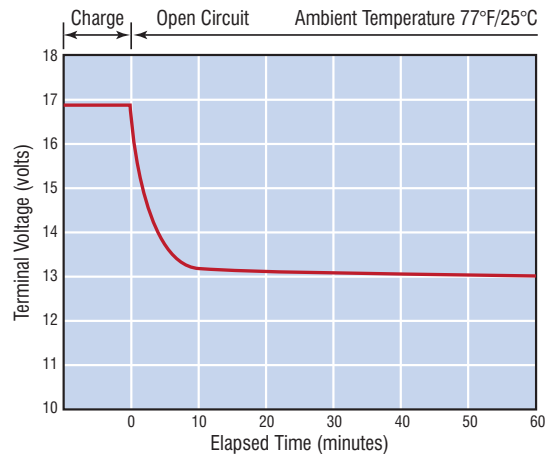

During the initial charging period, battery voltage may reach over 16 volts. Open circuit voltage should be checked after the battery is allowed to stand between 1 and 2 hours.

## HOW TO ACTIVATE A CONVENTIONAL BATTERY

Sealed at the Yuasa factory, a new Conventional battery has shelf life of 2 years from manufacturer as long as it remains sealed (filler caps and red vent cap installed) and is stored at room temperature. Once the battery is unsealed, it should be activated and put into service. The cell plates on an unsealed, uncharged battery will oxidize making charging difficult and reducing the service life of the battery.

- The battery must be out of the vehicle and placed on a level surface. Remove filling caps (red, yellow or green colored battery caps).
- **Remove the red sealing cap from the vent elbow.** If the battery has a red cap on the vent elbow, remove it and throw it away. Never put this cap back on the battery after it is filled with acid as the buildup of internal gas pressure can cause the battery case to rupture.

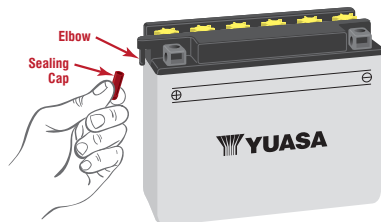

Always remove the red sealing cap from the vent elbow before filling and activating the battery.

- Using the acid bottle supplied with the battery, place the container upright on a flat surface. Carefully cut off the tip of the bottle's spout and attach the short tube provided. **Caution: Do not squeeze the bottle when cutting the fill tip. Do not smoke when activating a battery or handling battery acid. Always wear plastic gloves and protective eye wear.**
- Fill the battery with electrolyte supplied with the battery. Do not use water or any other liquid to activate a battery. Electrolyte should be between 60° F and 86° F before filling. If electrolyte is stored in a cold area, it should be warmed to room temperature before filling. Fill to the UPPER LEVEL as indicated on the battery. *NOTE: Never fill/activate a battery installed in a vehicle as electrolyte spillage can cause damage.*

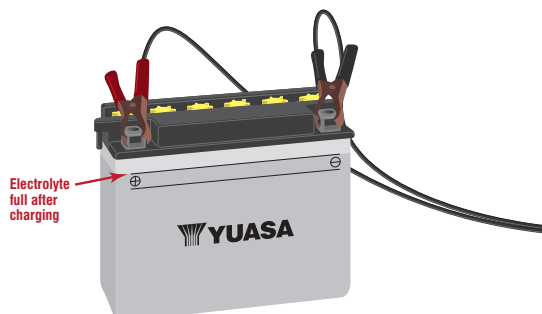

Make sure that the acid level is to the upper mark after the battery is initially charged. If the level is low fill with electrolyte.

- Fill each battery cell slowly and carefully to the highest level line.
- Let the battery stand for at least 30 minutes after filling. Move or gently tap the battery so that any air bubbles between the plates will be expelled. If the acid level has fallen, refill with acid to upper level.

### Post-Fill Stand Time

#### Amp-Hour

< 18  
> 18  
High Performance

#### Stand Time

30-60 minutes  
1-2 hours  
1-2 hours

- Filling a Conventional battery with electrolyte will bring it to 75-80% of a full charge. **A battery must be charged to 100% before putting it into service.** To find recommended charging current requirements in amps for a specific battery, divide battery ampere-hour capacity rating by 10. For example a 14 AH battery should be charged at 1.4 amps ( $14 \text{ AH} \div 10 = 1.4 \text{ amps}$ ). The specific gravity of the electrolyte should rise to at least 1.260 on 12N series batteries. On all High Performance batteries (YB Series) a minimal reading of 1.280 should be observed.
- During initial charging, check to see if the electrolyte level has fallen, and if so, fill with acid to the UPPER LEVEL. After adding acid, charge for another hour at same rate as above to mix the water and acid together. Note: This is the last time electrolyte should be added to the battery. If the level is low during use, distilled water should be added as required.
- When charging is complete, replace filler cap plugs and tighten by hand—**do not use a screwdriver or pliers.** Wash off spilled acid with a water and baking soda solution, paying particular attention that any acid is washed off the terminals. Dry the battery case and install the battery.



## BATTERY INSTALLATION

In most applications, batteries should be installed in an upright position. If there is any question regarding a particular vehicle/battery/installation please contact us for our specific recommendations before installation. [www.yuasabattery.com](http://www.yuasabattery.com)

AGM batteries that come with separate acid packs that are used to fill and activate the battery should not be installed in any position other than upright, as possible electrolyte leakage may occur. Also, **Conventional and Yumicron batteries should never be installed in any position other than upright as their liquid electrolyte will leak from the battery case causing damage to the vehicle.**

**Disclaimer:** *Yuasa batteries are to be mounted in a position identical to the position in which they were mounted in the vehicle by the manufacturer. Any position other than the "0°" position (upright) requires a "non-spillable" "Factory Activated" battery.*

Yuasa Battery assumes no responsibility for damages and/or injuries incurred due to a battery being mounted in a position other than what was originally used in the vehicle by the manufacturer. All "-BS" and Conventional "Flooded" batteries are to be mounted in the "0°" (upright) normal/center position.



## INSPECTING A BATTERY

Battery testing should begin with an inspection of the battery using the following steps:

- **Make sure the top of the battery case is clean and dry.** If the case of a battery is dirty it can cause the battery to discharge through the grime on top of the case. Use a soft brush and water and soap or a solution of baking soda and water to clean the battery case or terminals. On a Conventional battery, make sure filler

cap plugs are finger tight so cleaning materials will not enter the cells and neutralize the acid.

- **Inspect battery terminals, screws, clamps and cables for problems including: breakage, corrosion or loose connections.** Clean the terminals and clamps with a wire brush. Once battery cables are installed, dielectric grease (available at most auto parts stores) or clear lacquer from a spray can applied to the terminals will help prevent oxygen from causing corrosion on the battery terminals.
- **Inspect the battery case for obvious damage such as cracks or leaks;** look for discoloration, warping or raised battery case top, which may indicate that battery has overheated or been overcharged.
- **For Conventional batteries, check electrolyte level and add distilled water if necessary. Don't add acid—only distilled water.** Before any testing, charge the battery so the water and acid mix.

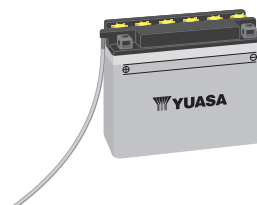

- **If equipped, check the battery vent tube. Make sure it's not kinked, pinched or otherwise obstructed.** On a motorcycle, it should exit away from the drive chain and from below the swing arm. Small cuts in the tube near the battery vent are OK; they form an emergency escape for trapped gas in case the vent tube becomes obstructed.

## BATTERY TESTING – HYDROMETER

Conventional batteries have filler caps which their state-of-charge can be checked using a hydrometer by measuring specific gravity. If, after charging, the battery's specific gravity does not increase to indicate a full charge, the battery should be replaced.

A hydrometer measures the ratio of sulfuric acid to water, or the specific gravity of the electrolyte. The specific gravity for pure water is 1.000 and sulfuric acid has an specific gravity of 1.835. Combined, their specific gravity is controlled at 1.280.

Yumicron batteries use sulfate stop, a chemical additive that increases battery life by reducing sulfate buildup. Sulfate stop may cause a slight increase in specific gravity readings for these types of batteries. **A battery's specific gravity changes with temperature.** Ideally, readings should be taken at 77° F. If the temperature is much colder or hotter, a conversion factor can be used to obtain an accurate reading. Add .001 to the specific gravity for every 3° F above 77° F and subtract .001 from the specific gravity for every degree below 77° F. Specific gravity has a direct relationship to battery cell voltage. By adding .84 to the specific gravity number, the cell voltage can be calculated. For example, an specific gravity of 1.280 + .84 = 2.12 volts. Multiply 2.12 volts x 6 (six cells for a 12 volt battery) and the result is 12.72 volts—indicating a fully charged battery.

## BATTERY TESTING – DIGITAL BATTERY PRINT TESTER



Yuasa's digital battery print tester uses single load dynamic resistance technology to calculate battery performance. The test provides information on open circuit voltage, state-of-charge, both charged and discharged batteries and system check. Before testing be sure to:

- Make sure the area around battery is well ventilated while battery is being tested.
- Clean battery terminals. Be careful to keep corrosion from coming in contact with eyes.
- Inspect the battery for cracked or broken case or cover
- If battery is damaged, do not use tester.

- If the battery is not sealed maintenance free, add distilled water in each cell until battery acid reaches level specified by the manufacturer. This helps purge excessive gas from cells. Do not overfill.
- If necessary to remove battery from vehicle to test, always remove ground terminal from battery first. Make sure all accessories in the vehicle are off to ensure you do not cause any arcing.

## DIGITAL BATTERY TESTER INSTRUCTIONS

- When testing a battery in a powersports vehicle, turn off the vehicle and all accessory loads. The battery will hold surface charge if the engine has been running for a while or after the battery has just been charged. For a battery in a powersports vehicle, please turn on the headlights for 30 seconds to remove the surface charge.
- Make sure the battery terminals are clean. Wire brush them if necessary. Clamp the black load lead to the vehicle negative battery terminal. Clamp the red load lead to the vehicle positive battery terminal.
- Make sure you insert 4 AA batteries into the battery chamber located on the back of the tester. Oxryde batteries are not recommended because of the initial 1.7 volt output. If the 1.5 volt battery runs out of power, screen will show “REPLACE INTERNAL BATTERY” or “POWER LOW”. Replace those 4 AA batteries before starting the test.
- You will see the battery voltage measured as connecting to battery. Press «ENTER» key

BATTERY VOLT  
XX.XXV

- Press ◀▶ key to select the battery type:

- STAND
- VRLA/MF/AGM/SLA

BATTERY TYPE  
STANDARD SLI

- Press «ENTER» to confirm choice

- Press ◀▶ key to input the battery capacity of AH: 2~35 Press «ENTER» to begin the test
- Press the ◀▶ key to select battery charged: Yes or No Press «ENTER» to confirm choice

When test is completed, the display shows the actual volts, SOH (state of health) or SOC (state of charge). One of six results will be displayed:

GOOD & PASS

The battery is good & capable of holding a charge.

GOOD & PASS  
XX.XXV

GOOD & RECHARGE

The battery is good but needs to be recharged.

GOOD & RECHARGE  
XX.XXV

RECHARGE & RETEST

Battery is discharged. The battery condition cannot be determined until it is fully charged. Recharge & retest the battery.

RECHARGE & RETEST  
XX.XXV

BAD & REPLACE

The battery will not hold a charge. It should be replaced immediately.

BAD & REPLACE  
XX.XXV

BAD CELL & REPLACE

The battery has at least one cell short circuit. It should be replaced immediately.

BAD CELL & REPLACE  
XX.XXV

## PAPER LOAD



Part No. YUABTY01PPR

LOAD ERROR

The tested battery is bigger than 200 AH, or the clamps are not connected properly. Please fully charge the battery and retest after excluding both previous reasons. If reading is the same, the battery should be replaced immediately.

LOAD ERROR

PAPER LOAD STEPS

Open the clear cover. Insert paper to the paper feeding for running the paper into printer automatically.

### STEP 1

Clamp to the battery

### STEP 2

Open the clear cover

### STEP 3

Feed the paper into the paper slot until it runs automatically

## SYSTEM CHECK

- Press «ENTER» key, you will view the screen

SYSTEM TEST  
XX.XXV

- Turn off all powersports vehicle accessories such as lights, radio, etc. before starting the engine

TURN OFF ACC.  
START ENGINE

- When the engine is started, one of the three results will be displayed along with the actual reading measured:

CRANKING VOLTS NORMAL

The system is showing normal draw.

Press «ENTER» to perform the charging system test.

CRANKING VOLTS  
XX.XXV NORMAL

CRANKING VOLTS LOW

The cranking voltage is below normal limits, troubleshoot the starter with manufacturers recommended procedure.

CRANKING VOLTS  
XX.XXV LOW

CRANKING VOLTS NOT DETECTED

The cranking voltage is not detected.

CRANKING VOLTS  
NOT DETECTED

- If the cranking voltage is normal, press «ENTER» to begin charging system test
- Press the «ENTER» button, you will view the screen

PRESS ENTER FOR  
= CHARGING TEST =

MAKE SURE ALL  
ACC. ARE OFF

- Press «ENTER» key, one of the three results will be displayed along with the actual reading measured.

LOW CHARGING VOLTS WHEN TEST AT IDLE

The alternator is not providing sufficient current to the battery. Check the connections from the alternator to the battery. If the connection is loose or heavily corroded, clean or replace the cable and retest. Contact qualified technician if condition remains the same.

ALT. IDLE VOLTS  
XX.XXV LOW

CHARGING SYSTEM NORMAL WHEN TEST AT IDLE

The system is showing normal output from the alternator. No problem is detected.

ALT. IDLE VOLTS  
XX.XXV NORMAL



## HIGH CHARGING VOLTS WHEN TEST AT IDLE

The voltage output from the alternator to the battery exceeds the normal limits of a functioning regulator. Check to ensure there is no loose connection and the ground connection is normal. If there is no connection issue contact a qualified technician.

- Following the charging system at idle, press «ENTER» for the charging system with accessory loads. Turn on high beam headlights.

ALT. IDLE VOLTS  
XX.XXV HIGH

## CHARGING SYSTEM HIGH WHEN TESTED WITH ACC.

The voltage output to the battery exceeds the normal limit of a functioning regulator. Check to make sure there are no loose connections and the ground connection is correct. If there are no connection issues, replace the regulator; since most regulators are now built into the alternator this will require the alternator to be replaced.

ALT. LOADS VOLTS  
XX.XXV HIGH

TURN ON LOADS  
AND PRESS ENTER

## CHARGING SYSTEM LOW WHEN TESTED WITH ACC.

The alternator is not providing sufficient current for the system's electrical loads and the charging current for the battery. Check the connections from the alternator to the battery, if the connections are loose or heavily corroded clean and replace the cable and retest. If the condition still exists see a qualified technician.

ALT. LOADS VOLTS  
XX.XXV LOW

## EXCESS RIPPLE DETECTED

One or more diodes in the alternator are not functioning or there is stator damage. Have the alternator tested and repaired or replaced.

RIPPLE DETECTED  
XX.XXV HIGH

## BATTERY MAINTENANCE

**AGM BATTERIES** do not have to be checked as often as Conventional batteries—about every three months, or three months from the date of battery activation at the factory if stored at room temperature. Higher storage temperatures cause faster self-discharge and requires that batteries be checked more often. The battery will last longer if it is 100% charged most of the time and any of the Yuasa automatic chargers will maintain a battery for optimum performance and long service life. AGM batteries have a predetermined quantity of electrolyte added at the factory or in the field specified for the battery. Once activated, the battery is permanently sealed and must never be opened. The addition of water is never required for an AGM battery. **The single most important aspect to maintaining an AGM battery is to not let it sit discharged for long periods of time—keep it fully charged for peak performance.**

**CONVENTIONAL BATTERIES** should be checked for state-of-charge about once per month if not used on a regular basis. Recharging may be required if the vehicle is not used for more than two weeks or if the starter turns slower than usual when starting the engine. A Conventional battery requires the periodic addition of distilled water when the electrolyte level becomes low. Water loss is normal in these batteries through the process of electrolysis and evaporation. Low electrolyte levels that expose the lead plates to the air will result in

permanent damage to the battery. Maintain the electrolyte levels above the minimum fill lines on the battery and at or below the maximum line. Clean terminals and connectors as necessary and make sure the vent tube is free of kinks or clogs. Always replace filler caps and finger-tighten only.

## BATTERY STORAGE

If the vehicle is in storage or used infrequently, disconnect the battery cable to eliminate current drain from electrical equipment. Check the battery every month (for Conventional types) and every three months for AGM batteries. If open circuit voltage indicates a low state-of-charge, charge the battery. **Temperatures below 60° F or above 80° F may require more frequent inspections and/or charging.**

## SULFATION AND FREEZING

The two most common reasons that batteries can become damaged are sulfation and freezing. These are not a problem if the battery is properly charged, and for Conventional batteries the water level is maintained. Battery sulfation takes place for two reasons: continuous discharging, or low electrolyte levels. When a battery discharges, the lead in the plates turn into lead sulfate. The lead sulfate is actually a crystal which grows larger when the discharge is continuous and uninterrupted. In a Conventional battery, low electrolyte levels expose the cell plates to air causing the lead material to oxidize and form sulfates.

In either case it doesn't take long before the battery won't hold a charge. Low electrolyte levels cause another problem because the acid in the electrolyte becomes more concentrated, causing the active material to corrode and fall to the bottom of the battery case. If this condition takes place over a long enough time period, the process will internally short out the battery.

## Electrolyte Freezing Points

Specific Gravity of Electrolyte	Freezing Point
---------------------------------	----------------

1.265	-75°F
1.225	-35°F
1.200	-17°F
1.150	+5°F
1.100	+18°F
1.050	+27°F

A battery that is fully charged can be stored at low temperatures without freezing. This chart shows that as specific gravity (state-of-charge) decreases, the battery will freeze at a higher temperature.

For added protection, Yuasa's Yumicron and AGM batteries are treated with a special chemical formula called "Sulfate Stop." This dramatically reduces sulfate crystal buildup on cell plates resulting in longer battery life. For example, Yuasa conducted a test on two batteries; one with sulfate stop, and the other without. Both batteries were under the constant discharge of a 10-watt bulb for a week. The battery with sulfate stop was charged with a 90% recover rate. The untreated battery could not be charged enough to put it back into service.

Freezing is not a problem with a fully charged battery. However if the battery becomes discharged (and the acid in the electrolyte turns into mostly water) the electrolyte will freeze. Freezing can cause a condition called "mossing" which is indicated by small red lines on the battery plates. Freezing can also crack the battery case and buckle the plates permanently damaging the battery. A fully charged battery can be stored at subfreezing temperatures with no damage. As the chart on this page indicates, a fully charged battery will not freeze unless the temperature drops below -75° F. By contrast a discharged (dead) battery will freeze at only 27° F. That's a difference of more than 100 degrees between the low temperatures a charged and discharged battery can withstand.









2901 Montrose Avenue, Laureldale, PA 19605 | 866.431.4784 | [yuasabattery.com](http://yuasabattery.com) | [customerservice@yuasainc.com](mailto:customerservice@yuasainc.com)

YUA-766 (01-20)