

Specification

Input Voltage	120VAC
Input Frequency	60 Hz
Output Voltage	6 VDC ± 0.5V / 12VDC ± 5%
Output Current	500 mA
Input Power (Watts)	12W
Operating Temperature	-10°C ~ +40°C
Storage Temperature	-25°C ~ +80°C
Connector	Alligator Clip
Standards	cUL, UL



Due to continuous improvements to our products, product images may vary slightly from depiction.

Dimensions: in(mm)

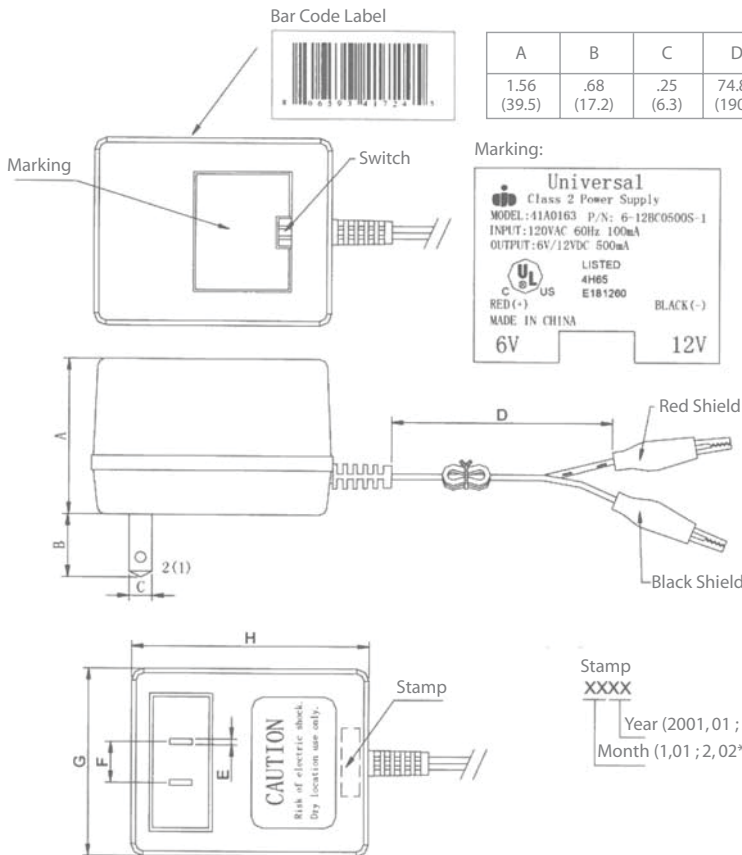

Circuit Diagram

