

Auto Meter[®]

Quality Test Equipment Since 1957



CHARGING SYSTEM **ANALYZER**

**OPERATOR'S
MANUAL**

CHARGING SYSTEM ANALYZER

Congratulations! On your new purchase of Auto Meter's Charging/Starting System Analyzer. It is designed to test each component of a vehicle's electrical system with speed and accuracy. If you should have any questions about your tester or the testing procedures, please give us a call at (815) 895-8141.

SPECIFICATIONS

Load Test Capacity	800 Amp
Meters	Two Digital, $\frac{3}{4}$ " Characters
Amp Range	Digital, 0-1200
Volt Ranges	Digital, 0-19.99, 20.0-199.9
Cooling	5" Internal Fan
Leads	Load Amp/Volt-10 ft., 2 Gauge/18 Gauge (2 Conductor) Inductive Amp Probe-10ft.
Size	10 $\frac{1}{2}$ " x 9" x 9 $\frac{1}{2}$ "
Weight	20 lbs.
Finish	Red Powder Paint
Stand	ES-1 (Optional)

CONTENTS

Controls and Functions	1
Orientation / Maintenance	2
Basic Tests:	
A. Safety	3
B. Inspection	3
C. State of Charge Battery Load Test	4
D. Hook-Up	5
E. Starting System	6
F. Charging System Overview	8
G. Regulator Bypass Test (Full Field)	9
H. Volt Regulator Test	10
I. Amp Draw Test	10
J. Voltage Drop Tests (for starting systems)	11
K. Voltage Drop Tests (for charging systems)	12
Appendices:	
I Battery Charging Guide	13
II Troubleshooting Tester Trouble	13
III Regulator Bypass Connections	15
Warranty and Service Information	30

CONTROLS AND FUNCTIONS

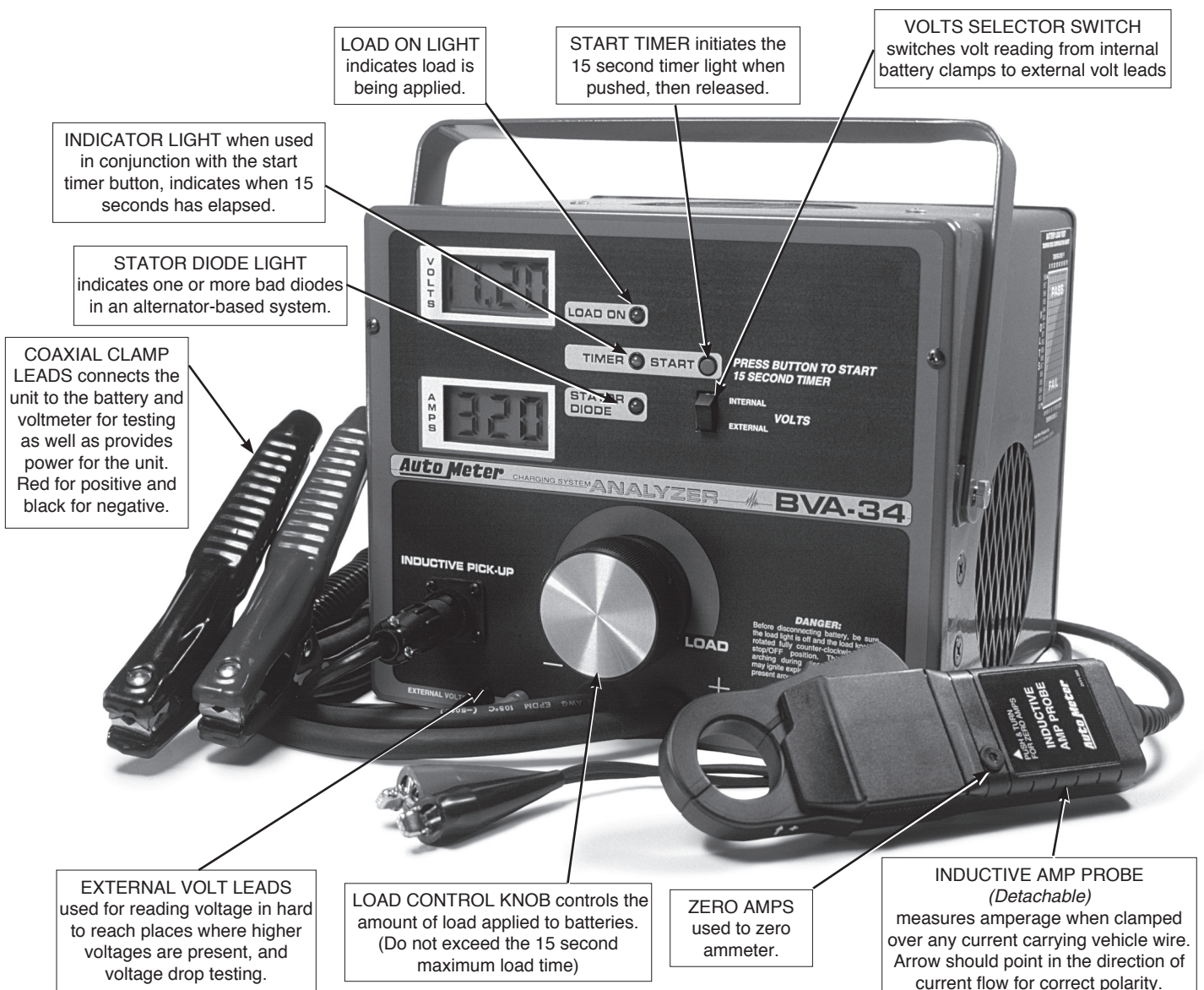

ORIENTATION / MAINTENANCE

If tester has not been used for awhile, moisture may have condensed between carbon pile discs. This will cause the tester to steam a little during first or second load application. This is normal and is not a malfunction of the tester. Do not confuse this with an overloading of the tester.

TESTER DUTY CYCLE:

To reduce wear and tear on the tester and to avoid overheating the carbon pile, the following duty cycle should be followed:

15 seconds on... 45 seconds off

Excess loading of the carbon pile without a "cooling off" period could cause damage.

----- WARNING -----

BE SURE LOAD IS OFF BEFORE
DISCONNECTING TESTER.

TESTER CARE AND MAINTENANCE

- Do not lay the inductive Amp probe on hot surfaces (ie. engine manifolds, etc.) Overheating can cause damage to the Probe.
- Keep probe & clamp surfaces clean, free of dirt and oil.
- Keep leads free of oil. Clean with warm, soapy water.
- Never insert an object into the fan vents. This can cause electrical and/or mechanical damage. Never cover the fan vents to allow for proper cooling of the tester.
- Never attempt to open up or repair the tester. Repairs should only be done by an authorized repair center. NOTE: Doing so could void the warranty.
- Do not disable the auto unload feature.
- Do not disable the auto unload feature. Always verify the load knob is off before disconnecting tester. Accidentally connecting/disconnecting the clamps to a battery with the load on can be very dangerous.

A

SAFETY

SAFETY PRECAUTIONS:

Carefully read all operating instructions before using.

Wear eye protection when working around batteries.

Load knob must be off before attaching or removing load clamps to prevent arcing and potential explosion.

Keep sparks, flames or cigarettes away from batteries.

Keep hair, hands, and clothing as well as tester leads and cords away from moving blades and belts.

Provide adequate ventilation to remove car exhaust.

In extremely cold temperatures, check for frozen electrolytic fluid before applying load.

Never connect large leads of this unit to more than a 12V battery. Connection to 24 volts will dangerously overload the carbon pile and circuitry. To test 24 volt systems see "D".

A. SAFETY



VISUAL CHECK

Inspect For:
Frayed, glazed, cracked or loose belt.

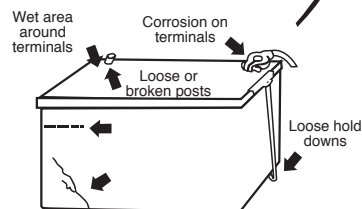

STATE OF CHARGE



Minimum
1.225

OPEN CELL
BATTERY

See "C" for tester hook-up.

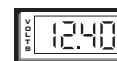

OR



SEALED TOP BATTERY

B

INSPECTION

VISUAL CHECK

Inspect and correct any frayed, glazed, cracked or loose belts; cracks in battery case; loose or broken posts; loose hold downs; low electrolyte level; corrosion on terminal; Wet area around terminals.

Inspect starter, solenoid, and regulator for: Loose connections, loose mounting of components, and frayed or cracked wires.

STATE OF CHARGE

1. OPEN CELL BATTERIES- Using a hydrometer, check the specific gravity of the electrolyte fluid. Typical specific gravity values are as follows.

Reading Of:	Indicates Battery Is:
1.265	100% Charged
1.225	75% Charged
1.190	50% Charged
1.155	25% Charged

These specific gravity values are applicable to an electrolytic temperature of 80°. The values must be adjusted for temperatures other than 80°, to do this: Add .004 for every 10 increments over 80°. Example: At 90° 1.265 +.004 =1.269. Subtract .004 for every 10° under 80°F. Example: at 70° 1.265 - .004 = 1.261.

Specific gravity must be 1.225 or above. If low, charge per battery manufacturers specifications. Apply a load equal to 1/2 cold crank amp rating for 5 seconds to remove surface charge.

There should not be more than 50 points spread between cells. If more than 50 points, replace battery.

2. SEALED TOP BATTERIES- (Maintenance Free) Battery must be at 12.4 volts or above before testing. If below 12.4, charge battery (See Appendix A) and apply a load equal to 1/2 cold crank rating load for 5 seconds to remove surface charge. Cold crank rating is explained under section "C" Battery Load Test. If battery reads less than 12.4 volts after recharging, replace battery. (6.2 volts for 6 volt batteries)

IMPORTANT NOTE: A defective battery must be replaced before proceeding.

Valid automotive electrical system testing depends on all the components being in good operating condition. In addition, the battery MUST have sufficient charge for testing. Carefully perform the following before attempting any electrical diagnosis. 1. Visual Check and 2. State Of Charge.

A FURTHER LOOK...

CAUSE OF BATTERY FAILURE.

1. INCORRECT APPLICATION: Wrong size battery may have inadequate cold cranking rating for original vehicle specifications.
2. INCORRECT INSTALLATION: Loose battery hold-downs cause excessive vibration which can result in damage to the plates.
3. IMPROPER MAINTENANCE: Low electrolytic fluid and corrosion on battery connections, can greatly reduce battery life and affect battery performance.
4. AGE OF BATTERY: If the date code on the battery indicates it is fairly old, the failure may be caused by natural causes.
5. OVERCHARGING: Overcharging caused by a high voltage regulator setting or incorrect battery charging can cause excessive gassing, heat and water loss.
6. UNDERCHARGING Undercharging caused by a faulty charging system or low voltage regulator setting can cause lead sulfate to gradually build up and crystalize on the plates greatly reducing the battery's capacity and ability to be recharged.

C

BATTERY LOAD TEST

1. HOOK-UP FOR BATTERY LOAD TEST

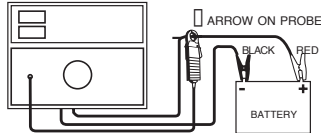

2. ZERO AMMETER (IF NECESSARY)

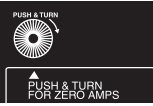

3. LOAD BATTERY

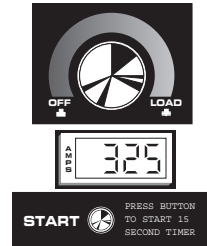

4. READ VOLTS



3. TIMER

5. TURN OFF LOAD



LEAVE THE COOLING FAN ON FOR 15 SECONDS, WITH LOAD OFF TO REDUCE OVER HEATING.

WARNING

BE SURE TO TURN FAN & CIRCUIT OFF BEFORE DISCONNECTING TESTER.

1. Hook-up for battery load test. (Individually) Be sure load is off before connecting. Do not connect tester to more than a 12 volt battery. To avoid sparks, connect negative lead to battery first and then connect positive lead. Multiple batteries must be disconnected and tested individually.
2. Set volts switch to internal setting.
- *3. Apply a load equal to 1/2 cold crank rating to battery (or 3x amp hour rating).
Example: Cold crank rating 500 CCA \div 2 = 250 amp load. Amp hour rating: 90 amp hours \times 3 = 270 amp load. Apply recommended load by turning load knob slowly clockwise. Push button for 15 second timer, indicator light will off. The recommended load must be maintained for the duration of the 15 seconds in order to accurately test the battery. The amperage will tend to drop as a normal reaction to the gradual decrease in voltage so the load must gradually be increased by turning the load knob clockwise. Indicator light will turn off after 15 seconds. Observe voltage reading.
4. Estimate the temperature of the electrolyte fluid when reading the pass/fail scale. The amount of voltage a battery can maintain when a load is applied decreases as the temperature decreases. Use the voltage chart at right to determine the correct minimum voltage. If voltage level was below specifications, battery should be replaced (or charged and retested). If voltage level was above specifications, battery is O.K.
5. Verify that the load is off before disconnecting tester.

A Battery must be able to turn over (crank) an engine while maintaining enough current to activate the ignition system. Batteries should be able to maintain 9.6 volts with an electrolyte temperature of 70° when a recommended load is applied.

A FURTHER LOOK... VOLTAGE CHART

Estimated Electrolyte Temperature	Minimum Required Voltage Under 15 Sec. Load	
	12V	6V
70°F Above	9.6	4.8
60°F	9.5	4.75
50°F	9.4	4.7
40°F	9.3	4.65
30°F	9.1	4.55
20°F	8.9	4.45
10°F	8.7	4.35
0°F	8.5	4.25

MULTIPLE BATTERY SYSTEM TESTS

For multiple batteries, the battery to be tested must be disconnected from all others.

WARNING

BE SURE LOAD IS OFF BEFORE DISCONNECTING TESTER.

- * To test a 6 volt battery with a CCA above 800 amps. Apply a load equal to 1/4 the CCA rating or 1.5 times the amp hour rating. Maintain the load to 30 seconds by pressing the timer button a second time immediately after the green LED turns off.

D

TESTER HOOK-UP

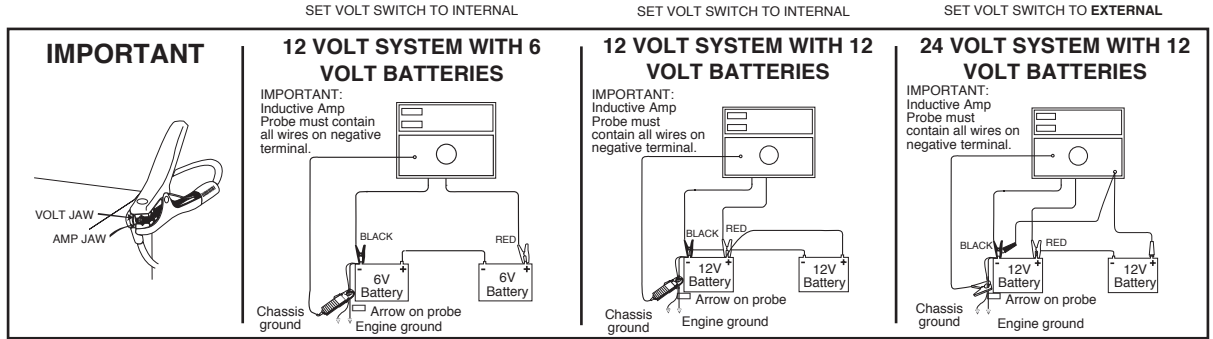

IMPORTANT:

- Both jaws of each clamp must firmly engage battery terminal. Take special care when testing side terminal batteries.
- If tester has volt reading but will not load, there is a poor connection on the silver jaw of the clamp.
- If tester has no volt reading but will load, there is a poor connection on the copper jaw of the clamp.
- For 24 volt system hook-up, set volt switch to external and use external leads to read voltage

WARNING:

- Be sure load is off before connecting.
- To avoid sparks connect negative lead first then positive.
- Do not connect large load clamps to more than 12 volts.
- After letting tester warm-up for one minute, zero ammeter before connecting Inductive Amp Probe.
- When connecting Inductive Amp Probe be sure it contains all wires on negative terminal; arrow on Inductive Amp Probe should be pointing toward the engine ground (away from the battery).

Assuring proper hook-up of the tester to the vehicle is essential to the accuracy of the test results.

A FURTHER LOOK...

The large load leads power the tester as well as measure voltage (internally). Keep large load leads connected to 12 volts and use the smaller voltage leads to measure higher voltage systems. Turn volt switch to the external position.

STARTING SYSTEM OVERVIEW

The sole purpose of the starting system is to turn over (crank) the engine fast enough for the engine to fire and run on its own. It is composed of a starter motor, a magnetic switch (usually a solenoid), a battery, an ignition switch, and usually a starting safety switch.

It is divided into two circuits: the starter circuit, and the control circuit. The **starter circuit** supplies high amperage current to the starter motor through the solenoid. The **control circuit** provides low amperage current to the solenoid when the ignition switch is turned to the start position.

When current is supplied, the **starter** turns the crankshaft flywheel. The **E. STARTER DRAW TEST** measures how much current the starter is drawing. If the starter draws too much current, there is a problem with the starter. If the starter draws too little current, there is probably too much resistance in the circuit or the **solenoid** is defective. Either of these low draw problems can be pinpointed using the **J. VOLTAGE DROP TEST**.

STARTING SYSTEM SYMPTOMS

Starter does not crank engine

Starter cranks engine too slowly

Starter rotates but does not crank engine.

POSSIBLE CAUSES

- Defective solenoid
- Open circuit
- Discharged battery
- Excessive resistance
- Defective starter
- Defective starter drive
- Excess engine bearing wear

DIAGNOSING THE PROBLEM

Be sure to visually check the battery, all cables and connections, and belt conditions and tensions before proceeding (see tests **B** and **C**).

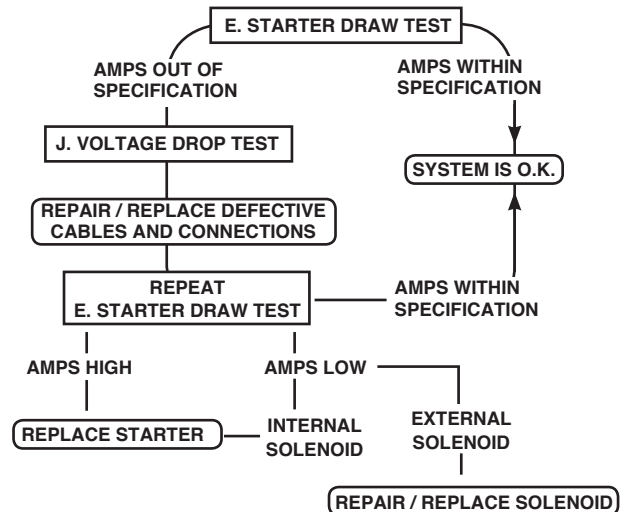
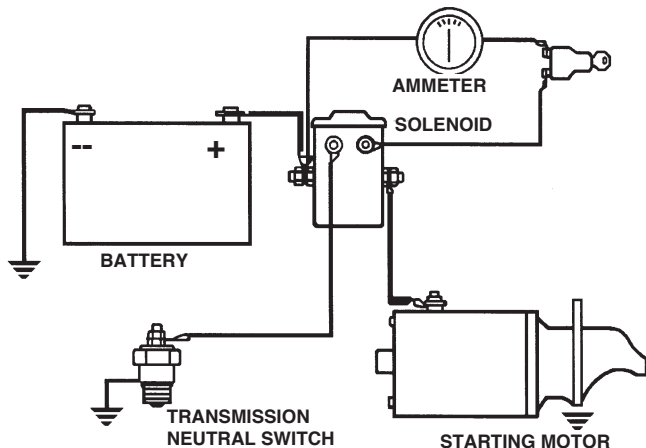

STARTER DRAW TEST

1. HOOK-UP TESTER

See "D" Tester Hook-up

2. ZERO AMMETER (IF NECESSARY)

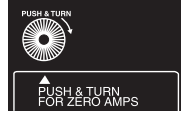

3. DISABLE IGNITION

4. CRANK ENGINE



Crank engine for 3-5 secs.

5. READ AMPS

1. Tester hook-up see instruction "D" for hook-up.
2. Set volts switch to internal volt setting.
3. Disable ignition system to prevent engine from starting when cranking.

On standard and electronic ignition: disconnecting the power supply can be done using one of two methods:

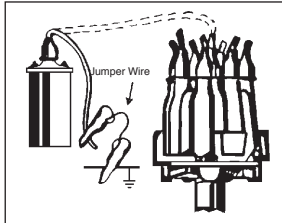

- For point type ignitions remove coil wire from distributor tower and securely ground it.

- For electronic ignitions disconnect power to the ignition by disconnecting it from the wiring harness.

On diesel vehicles: Disconnect the fuel shut-off solenoid. On Ford Motor Company vehicles it may be possible to disable the inertia switch which is typically located in the trunks on cars and under the dashboard on trucks and vans.

- Check with manufacturer's proper procedure to disable ignition. Improper method could cause damage to

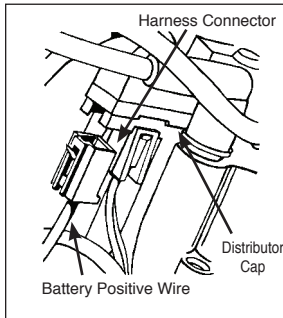

vehicles that are computer controlled.

4. Crank engine: Note the starter sound, does it sound sluggish? NOTE: A remote starter switch can be used to bypass the ignition switch and "crank" the engine from under the hood.
5. Read amps:
 - Observe amp meter reading, if within specifications, starter system is O.K. If manufacturer's specifications are not available the chart below can be used as a general guideline.

The starter draw test measures the amount of current needed to crank the engine which provides the initial information to diagnose and/or further test the starting system if necessary.

A FURTHER LOOK... STARTING SYSTEM

What may appear to be a major problem may turn out to be a minor problem such as a loose or corroded connection. As mentioned previously, always check the battery, and starter/solenoid for visual defects. In addition to this, be sure check the ignition switch and any magnetic switches for the following: Loose mounting or connections. Bad wiring. Sticking contacts.

If out of specifications:

- Check cables and connectors for excessive voltage drop. See section **J. VOLTAGE DROP TEST**
- Repair or replace any defective cables or connectors.
- Retest system

If still out of specifications:

- A high amp reading indicates a faulty starter. Some possible causes are shorted windings, bent armature, broken housing or bad bearings. Repair and replace starter as needed.
- A low amp reading (under 150 amps) indicates a faulty solenoid. Repair or replace solenoid as needed.

Multiple battery systems:

- If more than one positive cable connects directly to the starter the individual amp readings from each cable must be added together to determine starter draw.

4 Cyl Gas	4 Cyl Dsl	6 Cyl Gas	6 Cyl Dsl	8 Cyl gas	8 Cyl Dsl
120-250	up to 350	up to 250	up to 450	up to 250	up to 650

(For truck, bus, and other heavy-duty engines and starters, refer to manufacturer's specifications.)

CHARGING SYSTEM OVERVIEW

When the engine is operating, the charging system converts mechanical energy into electrical energy to supply all of the car's electrical systems as well as to maintain the battery at full charge. The main components of the charging system are: an alternator (or generator), a regulator, a battery, an in-dash indicator, and the wiring.

The **alternator** generates a certain level of amperage depending on the vehicle's needs. The amperage output rating is usually stamped on the alternator housing. If the alternator is faulty, the maximum amp output will be low. The **F. ALTERNATOR OUTPUT TEST** measures this output. The test also indicates the presence of any open diodes in the system.

The alternator must be limited in order to not supply more voltage than needed which could cause excessive wear and damage to the electrical system. This is accomplished by the **regulator** which can be either internal (inside the alternator) or external. All external and some internal regulators can be bypassed in the **G. REGULATOR BYPASS TEST (FULL FIELD)** to determine if low voltage is caused by the alternator or regulator. The **H. VOLTAGE REGULATOR TEST** should also be done to insure that the regulator is maintaining the proper amount of voltage after the car has warmed up.

Loose or corroded terminal, connections and damaged or undersized wires can produce resistance which can cause the voltage to drop between charging system components. The **J. VOLTAGE DROP TEST** can pinpoint the source of these problems.

CHARGING SYSTEM SYMPTOMS

- Ammeter, voltmeter, or warning light indications.
- Battery has low state of charge.
- Alternator noise.

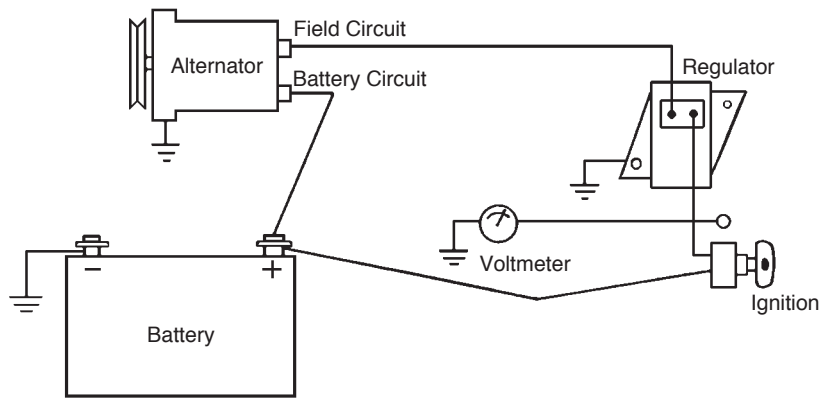



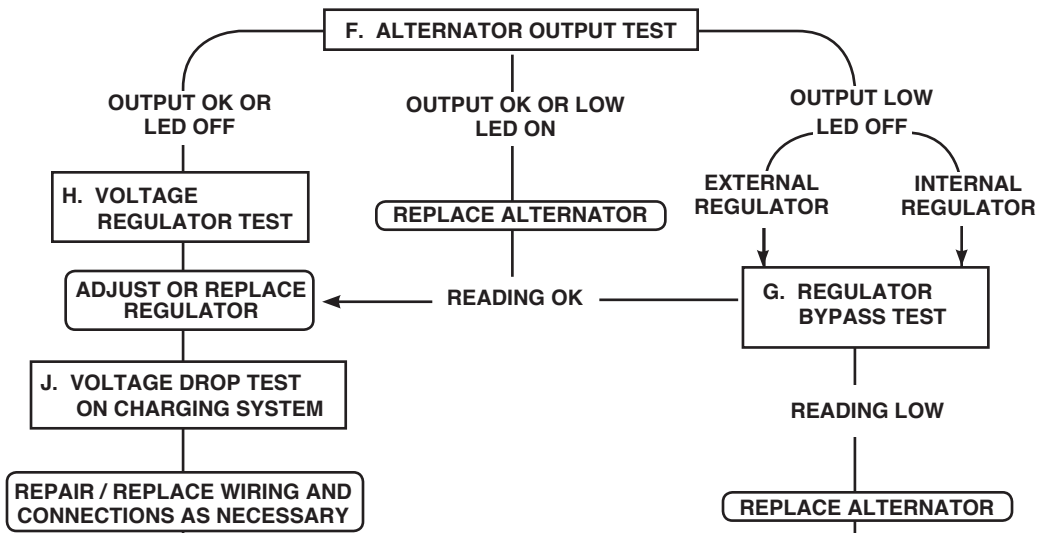

DIAGNOSING THE PROBLEM

Be sure to check the battery, all cables and connections, and belt condition and tension before proceeding (see tests **B** and **C**)

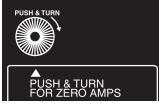
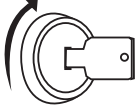

ALTERNATOR OUTPUT TEST

<p>1. HOOK-UP TESTER See "D" Tester Hook-up</p> <p>2. ZERO AMMETER (IF NECESSARY)</p> 	<p>3. TURN ON KEY AND READ KEY DRAW (AMPS) THEN START ENGINE.</p> 	<p>4. SLOWLY APPLY LOAD</p> 	<p>5. CHECK STATOR DIODE LED</p> 	<p>6. READ MAX. AMP OUTPUT OF ALTERNATOR. THEN TURN OFF LOAD.</p> 
---	--	--	--	--

1. Tester hook-up see instruction "D" for hook-up. Turn ignition on and read key draw before starting.
2. Start engine, idle at approximately 2000 rpm or to manufacturers test rpm.
3. Slowly apply load. Adjust load to obtain maximum alternator output on the amps scale. Do not allow voltage to drop below 12 volts or 24 volts on 24 volt systems. Use vehicle accessories if necessary to aid in applying load.
4. Check stator diode LED: If LED is on continuously, diode or stator is bad. Replace alternator. A bad or "open" diode or open stator windings can cause a slight drain on alternator output as well as causing other diodes to fail. This could eventually result in a failed regulator or dead battery.

NOTE: LED may flash during transient loading, only a steady light indicates a defect.

5. Read maximum amp output of alternator and remove load. Add key draw reading to alternator output. Output should be within 10-15% of manufacturers specifications.

■ If output is O.K. go to voltage **REGULATOR TEST STEP H.**

■ If output is low on the external regulator go to **REGULATOR BYPASS TEST STEP G**

■ If output is low on the internal regulator replace alternator.

NOTE: Check alternator for correct size pulley. (Too large may account for low output.)

■ Inductive Amp Probe in many cases might have to be placed on the output wire of the alternator to read maximum output.

This test accurately measures the maximum output of the alternator under maximum load conditions. This information provides the basis for further charging system tests. It also detects the presence of an open diode which causes an output loss of several amps and can cause the failure of other diodes.

A FURTHER LOOK...

ALTERNATOR TERMINALS

DELCO REMY- 10 SI

"BAT" = Alternator output to + battery.

"No. 1" = Battery current to rotor winding.

"No. 2" = Alternator output from battery.

DELCO REMY- 10 DN

"Bat" = Alternator output to + battery.

"GRD" = Additional ground

"R" = Indicator lamp

"F" = Rotor winding to regulator

MOTORCRAFT-Rear terminal

"BAT" = Alternator output to + battery

"STA" = Starter to various units including indicator lamp.

"FLO" = Rotor winding to regulator

"GRD" = Ground

SIDE TERMINAL:

Same except "STA" connects to rectified alternator output.

CHRYSLER:

"BAT" = Alternator output to + battery.

"GRD" = Ground

(2) "FLD" = Connects to 2 insulated brushes

REGULATOR BYPASS TEST (FULL FIELD)

1. ZERO AMMETER (IF NECESSARY)

See "D" Tester Hook-up

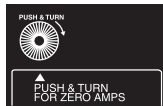

2. FULL FIELD ALT (Use Full Field Adaptor)

Field Term Plug.

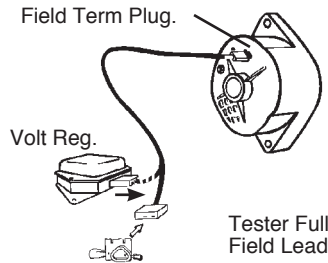

3. START ENGINE

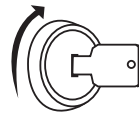

4. SLOWLY APPLY LOAD



5. READ MAX AMP OUTPUT OF ALT.



COMPARE TO VEHICLE SPECS.
IF LOW: REPLACE ALTERNATOR
IF OK: REPLACE REGULATOR
IF PREVIOUS: RESULTS WERE LOW
WARNING
 BE SURE LOAD IS OFF BEFORE DISCONNECTING TESTER.

- Hook-up tester. See step "D" for tester hook-up.
- Set volts switch to internal setting.
- Refer to Appendix IV for the proper way to bypass regulator. Full Field Adaptor Kit or equivalent is recommended.
- Start engine and slowly apply load, while running engine at fast idle to maintain voltage level shown below.

System Voltage	Range
12 Volts	12-15 Volts
24 Volts	24-30 Volts

Caution: To prevent damage to vehicle electrical circuits; do not let voltage rise above 15 volts for 12 volt systems or 30 for 24 volts.
 The alternator is un-regulated, and full output should be attained. If not replace alternator.

WARNING: Monitor voltage continuously from engine start. DO NOT exceed safe MAX Voltage. Turn off engine to avoid possibility of electrical damage to vehicle.

When a charging system has low voltage output either the alternator, regulator or the wiring in the system could be at fault. The regulator bypass test helps pinpoint the problem. If the alternator output is normal after bypassing the regulator, the regulator is defective. If the alternator output remains low after bypassing the regulator, the alternator is defective.

A FURTHER LOOK... FIELD CIRCUIT TYPES:

TYPE "A" field circuits are grounded externally through the regulator contacts.

Type "B" field circuits are grounded internally through the alternator.

TURN LOAD OFF

----- WARNING -----

BE SURE LOAD IS OFF BEFORE DISCONNECTING TESTER.

VOLTAGE REGULATOR TEST

1. HOOK-UP TESTER & ZERO AMMETER (IF NECESSARY)

See "D" Tester Hook-up

2. START ENGINE

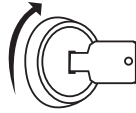

3. READ VOLTAGE



The voltage regulator test can be performed as a continuation of the alternator output test. It provides a means of assuring that the regulator is supplying the proper amount of voltage after the car has warmed up. (the initial amperage draw has tapered off and the battery is charged).

1. Hook-up tester. See step "D" for tester hook-up.
2. Start engine and read voltage
Make sure all accessories are turned off.
Keep engine speed at approximately 2000 - 2500 rpm.
Read volts after amps fall to 10 amps or less (with battery charged).

NOTE: Voltage regulators are temperature sensitive to provide adequate voltage needed at various temperatures. Measure the temperature near the regulator (A common meat thermometer will work). Check manufacturers specifications for temperature compensated voltage requirements.

If voltage is within manufacturers specifications: system is good.

If voltage is outside of manufacturers specifications:

- Adjust regulator to correct voltage. If factory specifications are not available, use chart in "A Further Look" for general voltage requirements.
- Retest- If out of specifications, check

regulator ground and repair if necessary. (Check for loose or corroded connectors).

- Retest- If reading is unsteady, erratic, or will not adjust. Replace regulator.

A FURTHER LOOK...

Overcharging caused by improper regulator setting is a major cause of premature battery failure. Make sure regulator is within specifications.

Voltage Regulator Setting at 70°.

13.6 - 13.8 V for conventional batteries.

13.9 - 14.1 V for maintenance free batteries.

AMP DRAW TEST

1. HOOK-UP TESTER & ZERO AMMETER (IF NECESSARY)

See "D" Tester Hook-up

2. PLACE INDUCTIVE AMP PROBE ON CIRCUIT WIRE.

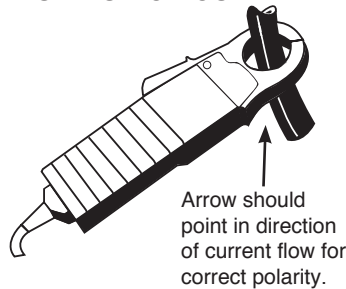

Faulty wiring can cause current draw even when all accessories are off, this current leakage can cause substantial battery drain. This test pinpoints any current leakage.

1. Hook-up tester. See step "D" for tester hook-up.
2. Attach Inductive Amp Probe to circuit wire. Arrow on probe should point in direction of current flow. Be sure all accessories are off (including clock and underhood light).

- Observe ammeter.
- If reading is present, current is being drawn. Locate draw and repair.
- If no reading is present there is no current leakage.

VOLTAGE DROP TEST (FOR STARTING SYSTEMS)

Loose or corroded terminal connections and damaged or undersized wires can produce resistance which causes the voltage to drop between starting system components. Using the following procedure, volt readings can be taken of each part of the circuit and then compared to the voltage of a normal circuit, pinpointing voltage drops.

1. Hook-up tester. See following diagrams for hook-up.
NOTE: The Inductive Amp Probe is connected to a load lead of the tester.

2. Set volt selector switch as indicated in the diagram.
3. Hook-up external leads to the part of the circuit being tested (see following diagrams for specific hook-up).
4. Load starter circuit to approximate starter draw specification.
5. Read Voltage.

24 VOLT SYSTEMS MUST BE CONNECTED TO A TEMPORARY 12 VOLT CONNECTION

OVERALL STARTING SYSTEM TURN VOLT SWITCH FROM INTERNAL TO EXTERNAL

ACCEPTABLE LEVELS - LESS THAN .5 VOLTS

Subtract internal voltage from external voltage. If more than a .5 volt drop, proceed to step 2 & 3 to locate which circuit has high resistance.

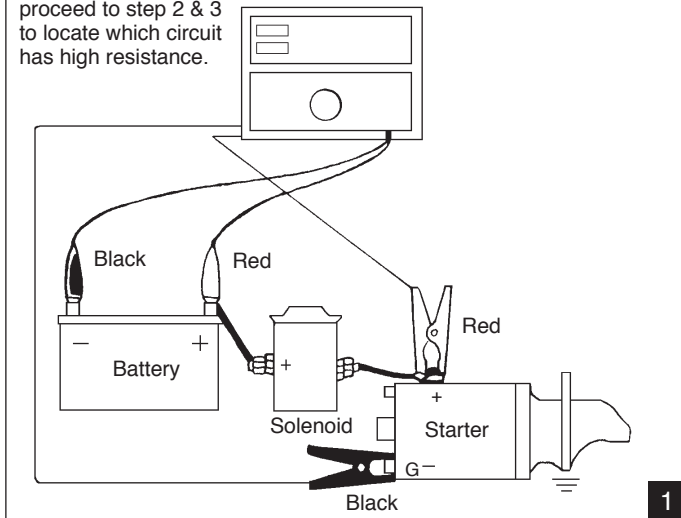

STARTER SYSTEM INSULATED CIRCUIT TURN VOLT SWITCH TO EXTERNAL - READ VOLTAGE DROP

ACCEPTABLE LEVELS

If drop is .5V or less, circuit is OK. If drop is more than .5V, repair circuit. Proceed to step 3.

Visually check for:

- Loose or corroded connections.
- Frayed or undersized wires.
- Bad contacts on the solenoid.

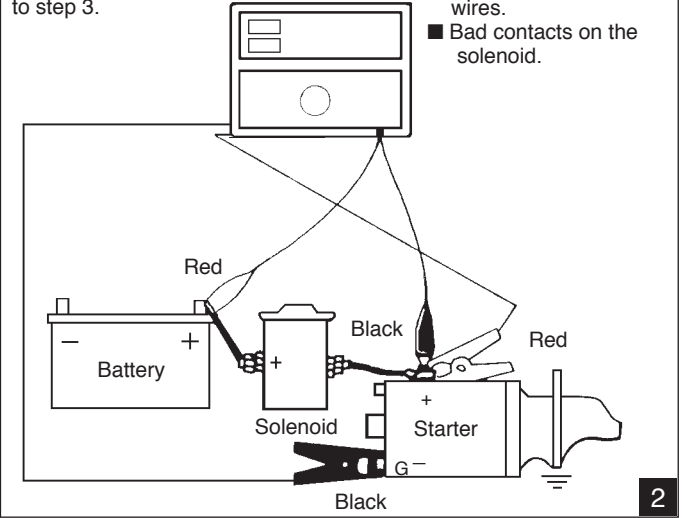

STARTER SYSTEM GROUND CIRCUIT TURN VOLT SWITCH TO EXTERNAL - READ VOLTAGE DROP

ACCEPTABLE LEVELS

If drop is .2V or less, circuit is OK. If drop is more than .2V, repair circuit - proceed to step 1 to check repairs.

Visually check for:

- Loose starter mounting bolts.
- Bad battery ground terminal.
- Damaged or undersized grounding cable from the battery to the engine block.

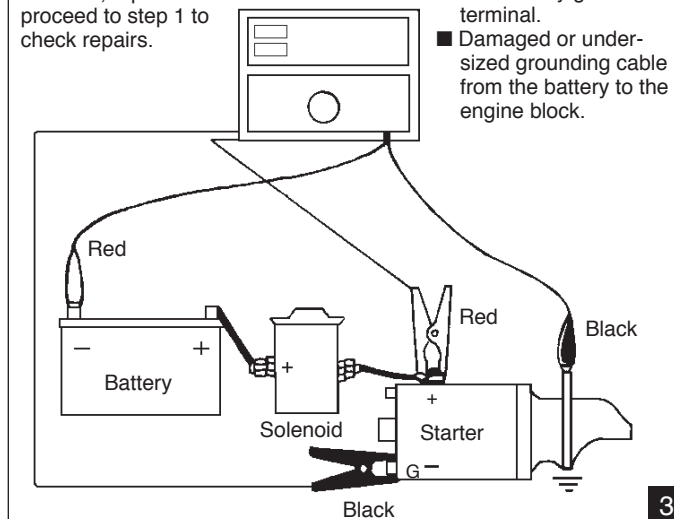

K

VOLTAGE DROP TEST (FOR CHARGING SYSTEMS)

Loose or corroded terminal connections and damaged or undersized wires can produce resistance, which causes the voltage to drop between charging systems components. Using the external volt leads, volt readings can be taken of each part of the circuit and then compared to the voltage of a normal circuit, pinpointing the source of resistance problems.

1. Hook-up tester. See following diagrams for hook-up.
NOTE: The Inductive Amp Probe is connected to a load lead of the tester.
2. Set volt selector switch as indicated in the diagram.
3. Hook-up external leads to the part of the circuit being tested. (See following diagrams for specific hook-up.)

4. Apply load by turning load knob clockwise. Increase load until ammeter reads the manufacturers specification for alternator output.
5. Observe voltage drop reading. NOTE: To check the overall charging system, turn volts switch to internal. Subtract the external reading from the internal reading and compare to manufacturers specifications.

24 VOLT SYSTEMS MUST BE CONNECTED TO A TEMPORARY 12 VOLT CONNECTION.

OVERALL CHARGING SYSTEM TURN VOLT SWITCH FROM INTERNAL TO EXTERNAL

NOTE: Subtract external voltage from internal voltage and compare to manufacture's specification. If more than acceptable, proceed to step 2.

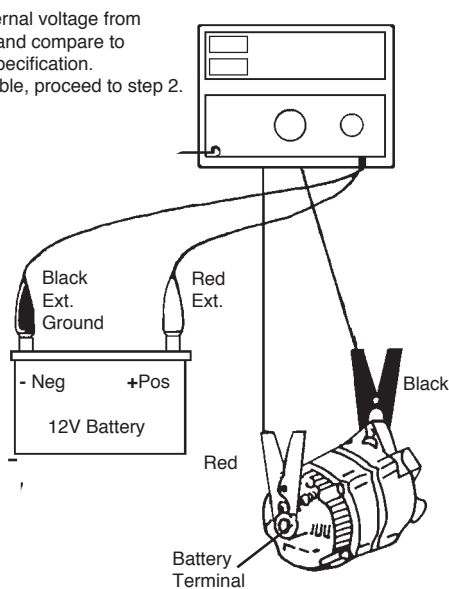

CHARGING SYSTEM INSULATED CIRCUIT TURN VOLT SWITCH TO EXTERNAL - READ VOLTAGE DROP

ACCEPTABLE LEVELS
If drop is .5V or less: Circuit is O.K.
If drop is more than .5V...
Visually check for:
■ Loose or corroded connections.
■ Frayed or undersized wires.
Proceed to step 3.

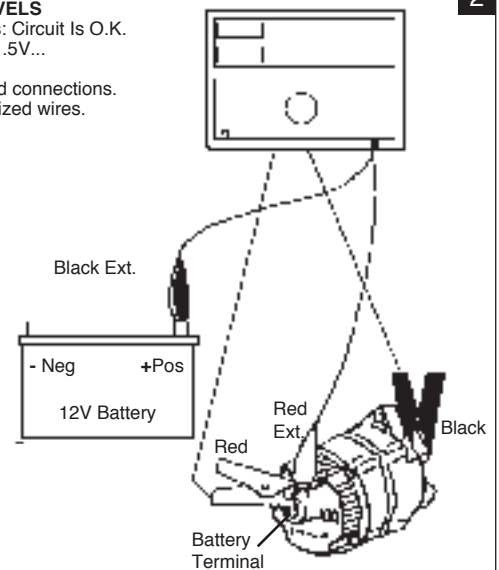

CHARGING SYSTEM GROUND CIRCUIT TURN VOLT SWITCH TO EXTERNAL - READ VOLTAGE DROP

ACCEPTABLE LEVELS
If drop is .5V or less: Circuit is O.K.
If drop is more than .5V...
Visually check for:
■ Loose or corroded connections.
■ Frayed or undersized wires.
After repairs are made, proceed to step 1 for final test.

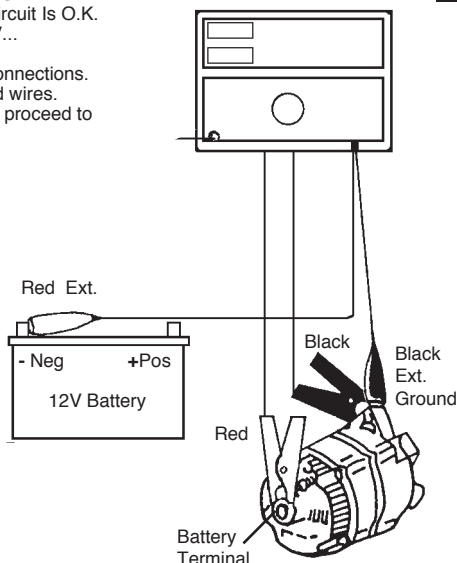

- If the amount of voltage drop is at or below the amount specified: that part of the circuit is functioning properly.
- If the amount of voltage drop is above the amount specified: move the leads progressively across each section of the circuit until the defective section is found.
- If the voltage level is within the specified levels: charging system does not have resistance problems.
- If voltage drop is more than the specified levels: individually check each section of the charging system.

OVERALL CHARGING SYSTEM ACCEPTABLE VOLTAGE DROP LEVELS

American Motors	.65 V. Maximum Drop
Chrysler	.9 V. Maximum Drop
Ford	.8 V. Maximum Drop
General Motors	.65 V. Maximum Drop

- If drop exceeds maximum level, proceed to determine which circuit may have a high resistance.

APPENDIX I BATTERY CHARGING GUIDE

NOTE: CHARGING RATES VARY AND DEPEND ON THE:

The battery capacity rating (in minutes):

The higher the rate... the longer the charging time required.

The degree of discharge:

A fully discharged battery requires 2 x's as much charging as 1/2 charged battery.

The battery condition and age:

An old battery and/or one in poor condition requires more charging time.

The electrolytic temperature:

The colder the temperature...the longer the charging time required.

Recommended charging rates for fully discharged batteries.

Battery Reserve Capacity (min.)	Charge Battery At: (slow charge on top fast charge on bottom)
80 minutes or less	14 hrs. at 5 amps 7 hrs. at 10 amps
81-125 minutes	20 hrs. at 5 amps 10 hrs. at 10 amps
126-170 minutes	28 hrs. at 5 amps 14 hrs. at 10 amps
171-250 minutes	42 hrs. at 5 amps 21 hrs. at 10 amps
251 minutes and above	33 hrs. at 10 amps

CAUTION: Exceeding recommended charging rates can damage battery plates and generate potentially explosive gases.

APPENDIX II TROUBLESHOOTING TESTER TROUBLE

PROBLEM	POSSIBLE CAUSES	SOLUTIONS
Sparks when attaching clamps to battery	A. Load turned on B. Tester power switch on	A. Turn load off B. Turn power switch off
Carbon pile steams	A. Moisture in carbon discs B. Overheating carbon pile	A. Not a problem-will remedy itself B. Follow duty cycle closely (15 sec. On 45 sec. off)
Tester loads but has no volt reading	A. Poor connection on copper side of clamp jaws.	A. Clean battery posts B. Reposition clamp, both sides of jaw must make contact
Tester has volt reading but does not load	A. Poor connection on silver side of clamp jaws	A. Clean battery posts B. Reposition clamp, both sides of jaw must make contact
Inaccurate amps reading	A. Dirty Inductive Amp Probe jaws B. Off zero	A. Clean jaws B. Adjust zero knob
Incorrect ammeter polarity	A. Inductive Amp Probe wrong direction	A. Turn Inductive Amp Probe around
Incorrect voltmeter polarity	A. External volt leads connections reversed	A. Switch volt leads connections

LIMITED WARRANTY
(12 MONTHS FROM DATE OF PURCHASE)

The manufacturer warrants to the consumer that this product will be free from defects in material or workmanship for a period of twelve (12) months from the date of the original purchase (except for carbons and leads, which are covered for 90 days). Products that fail within this 12 month warranty period will be repaired or replaced at the manufacturer's option to the consumer when determined by the manufacturer that the product failed due to defects in material and workmanship. This warranty is limited to the repair or replacement of parts in the tester and the necessary labor by the manufacturer to effect the repair or replacement of the tester. In no event shall this warranty exceed the original purchased price of the tester, nor shall the manufacturer be responsible for special, incidental or consequential damages or costs incurred due to the failure of this product. Breaking the meter seal, improper use, accident, water damage, abuse, unauthorized repairs or alterations voids the warranty. The manufacturer disclaims any liability for consequential damages due to breach of any written or implied warranty on its tester.

WARRANTY & SERVICE INFORMATION

Warranty claims to the manufacturer's service department must be transportation prepaid and accompanied with dated proof of purchase. This warranty applies only to the original purchaser and is non-transferable. Damage incurred during return shipment is not covered under this warranty. It is the responsibility of the shipper (customer returning tester) to package the tester properly to prevent any damage during return shipment. Repair costs for such damages will be charged back to shipper (customer return tester). Before packing tester for return shipment, tighten load knob to prevent breakage of carbon discs during shipment due to rattling. Also, protect the meters and add plenty of overpack cushioning, such as crumpled up newspaper.

AUTO METER PRODUCTS, INC.

413 W. Elm St. Sycamore, IL 60178
Toll Free (866) 883-TEST (8378)
Fax (815) 895-6786
www.autometer.com

2650-792X-10
Rev. C