



# POWER FORGED™

## Battery Charger Service Parts

PLP BATTERY SUPPLY  
 Murphysboro, IL 62966  
 800-642-3451

### 697202 Timer Kit – Installation Instructions

120-Minute Electromechanical Timer w/ Hold, 120 VAC – Screw mount. Replaces Associated 611245.

**Contents:**

- 1 – 697200, 120-minute timer – screw mount
- 1 – 696550, knob w/clip retainer (replaces Associated 603147)
- 2 – 609052, mounting screws
- 1 – 609063, timer dial label (horizontal timers)
- 1 – 609064, timer dial label (vertical timers)
- 1 – instruction sheet

#### Back of Timer with Terminal Labels

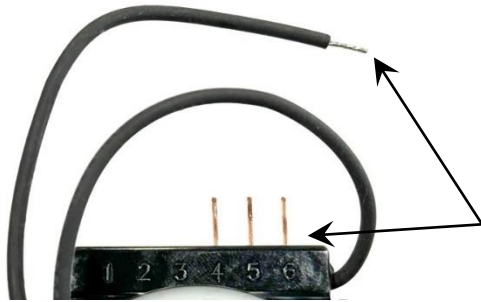

This timer kit contains components necessary to replace the 611245 timer found in Associated Equipment battery chargers. These are exact OEM replacement parts. Timer dial labels are included for use on chargers that have damaged or illegible timer dial printing.

This timer can also be retrofitted in other chargers to replace obsolete electromechanical timers. The enclosed dial labels are particularly helpful in retrofit applications – for example, replacing a 90-minute timer.

#### Timer Terminal Connections

There are 3 push-on, 1/4" terminals and 1 loose wire for the electrical connections to this timer.

#### 697200-697201 Circuit Function

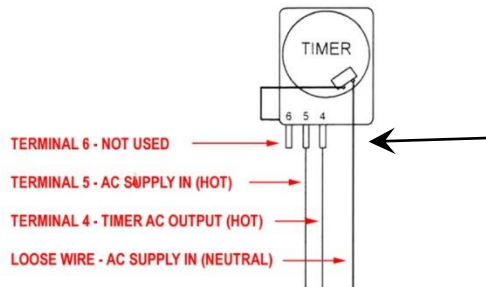

#### Timer Circuit Function

Terminal 5 and the loose wire are the AC input required to run the timer, usually from the AC power cord.

Terminal 4 is the AC output to supply the charger with power – usually sending the timer-controlled AC current to the transformer or rate select switch. Current flows when the timer is in an "ON" position – either while counting down or in the HOLD position.

Terminal 6 is not used.

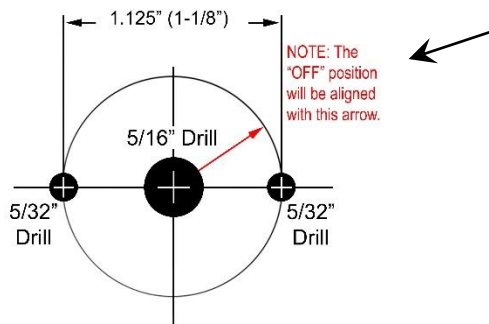

#### Panel Mounting Instructions

If it is necessary to drill or punch holes to mount the timer, the template at left may be used to mark the cabinet for drilling or punching. The panel will need three holes, in accordance with the diagram. The timer knob stem fits through the center hole, and the smaller holes accept the mounting screws.

Dial label 609063 is used for this horizontal screw configuration.

If the mounting screw holes are vertically aligned, rotate the template 90 degrees counter-clockwise. This places the OFF position at approximately 11 o'clock from the stem.

Dial label 609064 is used for the vertical screw configuration.

**Questions?**

**We are here to help.**



**Call us: 800-642-3451**  
**or email: info@plpbattery.com**

697202 Installation Sheet.pdf  
 © 2024, PLP Battery Supply  
 Rev 04/2024



# POWER FORGED™

## Battery Charger Service Parts

PLP BATTERY SUPPLY  
 Murphysboro, IL 62966  
 800-642-3451

### Installation & Wiring Examples for Various Associated Chargers

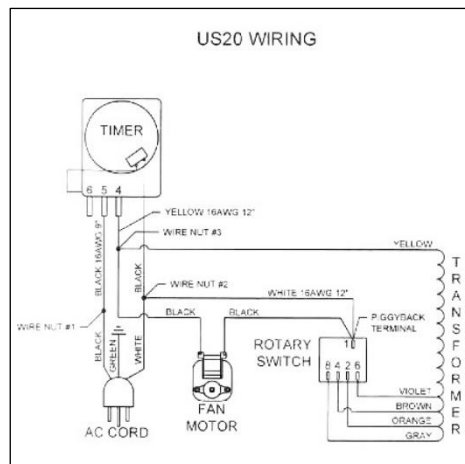
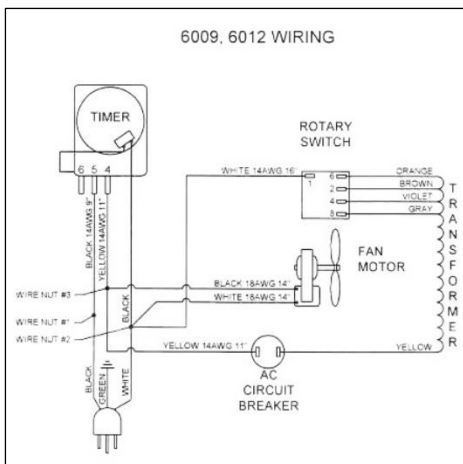
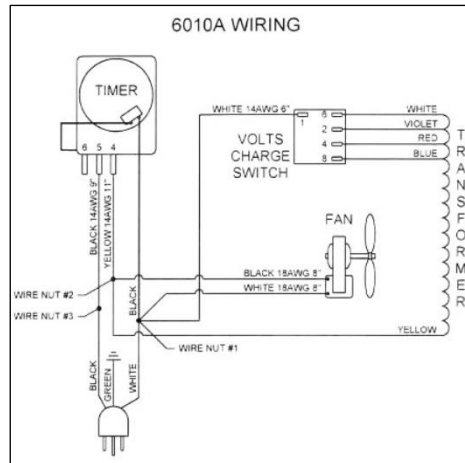
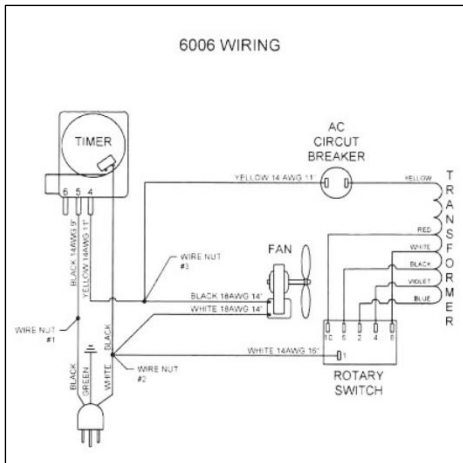
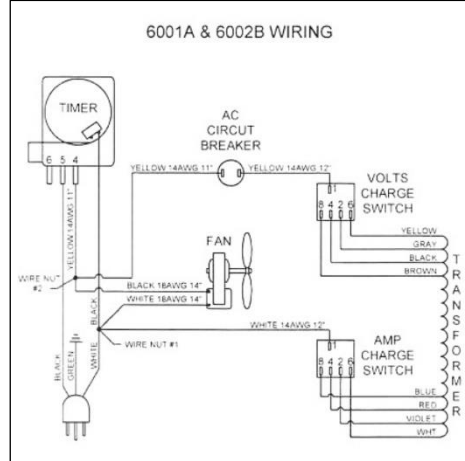
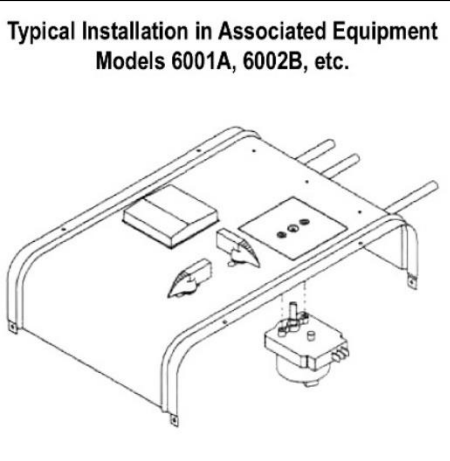

Questions?

We are here to help.



Call us: 800-642-3451  
 or email: info@plpbattery.com

697202 Installation Sheet.pdf  
 © 2024, PLP Battery Supply  
 Rev 04/2024