



POWER FORGED™

Battery Charger Service Parts

PLP BATTERY SUPPLY
Murphysboro, IL 62966
800-642-3451

697201 Electromechanical Timer ONLY – Threaded Bushing Mount

120-Minute Electromechanical Timer w/ Hold, 120 VAC - Threaded Bushing Mount

KContents:

- 1 – 697201, 120-minute timer, includes mounting nut & washer
- 1 – instruction sheet

Back of Timer with Terminal Labels

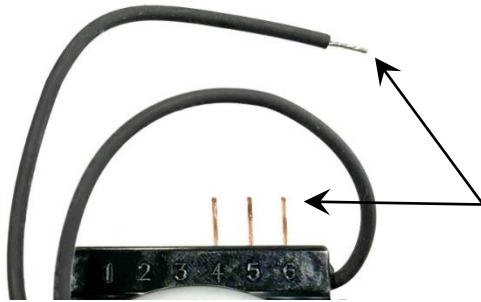

This timer replaces obsolete electromechanical timers in a variety of older battery chargers.

Note that the installation of this timer is not a direct “bolt-in” replacement. Some modification of the charger cabinet may be necessary (e.g.- drilling holes), as well as a basic electrical knowledge and skill level.

Basic electrical tools are necessary. A multi-meter may also be required.

697200-697201 Circuit Function

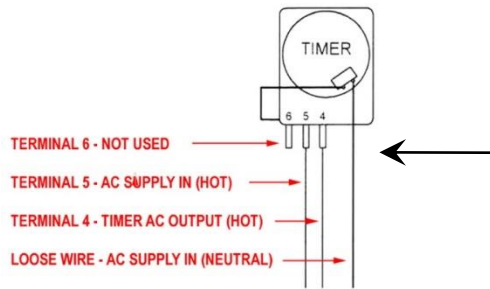

Timer Terminal Connections

There are 3 push-on, 1/4” terminals and 1 loose wire for the electrical connections to this timer. Your application will dictate the connection method of the loose wire – it may use a wire nut (wrapped in electrical tape), or a crimped terminal to properly connect.

Timer Circuit Function

Terminal 5 and the loose wire are the AC input required to run the timer, usually from the AC power cord.

Terminal 4 is the AC output to supply the charger with power – usually sending the timer-controlled AC current to the transformer or rate select switch. Current flows when the timer is in an “ON” position – either while counting down or in the HOLD position.

Terminal 6 is not used.

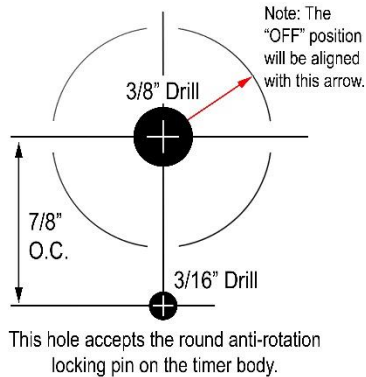

Panel Mounting Instructions

If it is necessary to drill or punch holes to mount the timer, the template at left may be used to mark the cabinet for drilling or punching. The panel will need two holes, in accordance with the diagram. The timer knob stem fits through the 3/8” hole, and the smaller 3/16” hole accepts the anti-rotation locking pin on the timer body. (Dial label 609063 is used for this horizontal screw configuration. Order separately, or in kit 697203.)

An optional orientation is to rotate the template 90 degrees counter-clockwise to mark and drill the holes. This places the OFF position at approximately 11 o'clock from the stem.

(Dial label 609064 is used for the vertical screw configuration. Order separately, or in kit 697203.)

Questions?

We are here to help.



Call us: 800-642-3451
or email: info@plpbattery.com

697201 Installation Sheet.pdf
© 2024, PLP Battery Supply
Rev 04/2024



POWER FORGED™

Battery Charger Service Parts

PLP BATTERY SUPPLY
 Murphysboro, IL 62966
 800-642-3451

Installation & Wiring Examples for Various Associated Chargers

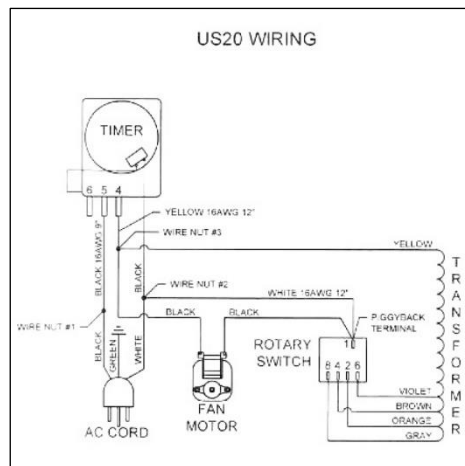
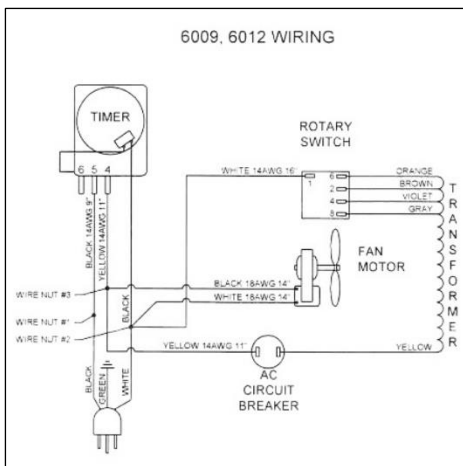
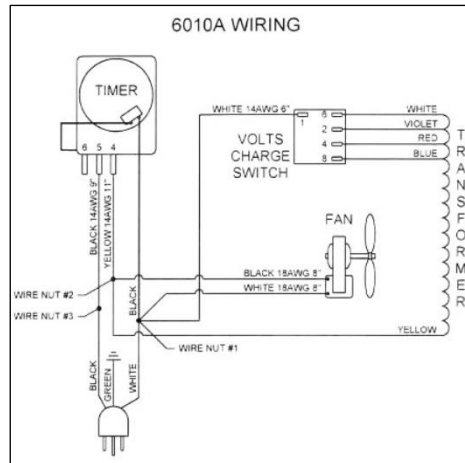
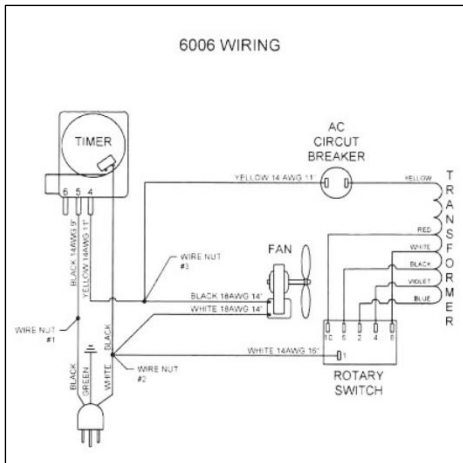
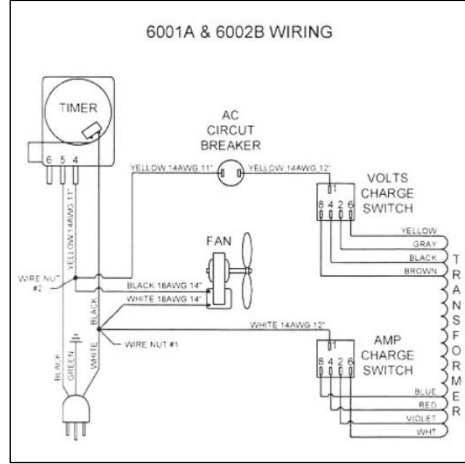

Questions?

We are here to help.



**Call us: 800-642-3451
 or email: info@plpbattery.com**

697201 Installation Sheet.pdf
 © 2024, PLP Battery Supply
 Rev 04/2024