

# Jabra Engage 75

Questions?  
Click to Live Chat

A third-party certification according to ISO 14024



Toward sustainable IT products

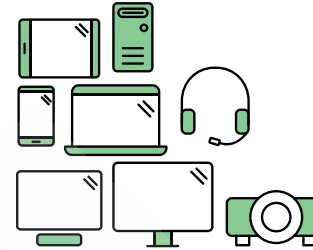

## Say hello to a more sustainable product

IT products are associated with a wide range of sustainability risks throughout their life cycle. Human rights violations are common in the factories. Harmful substances are used both in products and their manufacture. Products can often have a short lifespan because of poor ergonomics, low quality and when they are not able to be repaired or upgraded.

**This product is a better choice.** It meets all the criteria in TCO Certified, the world's most comprehensive sustainability certification for IT products. Thank you for making a responsible product choice, that help drive progress towards a more sustainable future!

Criteria in TCO Certified have a life-cycle perspective and balance environmental and social responsibility. Conformity is verified by independent and approved verifiers that specialize in IT products, social responsibility or other sustainability issues. Verification is done both before and after the certificate is issued, covering the entire validity period. The process also includes ensuring that corrective actions are implemented in all cases of factory non-conformities. And last but not least, to make sure that the certification and independent verification is accurate, both TCO Certified and the verifiers are reviewed regularly.

### Want to know more?

Read information about TCO Certified, full criteria documents, news and updates at [tcocertified.com](http://tcocertified.com). On the website you'll also find our Product Finder, which presents a complete, searchable listing of certified products.



## User manual



**Questions?  
Click to Live Chat**

- 1. Welcome.....6
- 2. What’s in the box.....7
  - 2.1 Stereo variant
  - 2.2 Mono variant
  - 2.3 Convertible variant
- 3. How to wear..... 10
  - 3.1 Stereo/Mono headset
  - 3.2 Convertible headset
  - 3.3 How to change mono headset wearing styles
  - 3.4 How to change the convertible headset EarGels
  - 3.5 How to change the convertible headset EarHook
  - 3.6 How to change the convertible headset wearing style
- 4. How to charge ..... 15
  - 4.1 Connect to power
  - 4.2 Charge the headset
  - 4.3 Headset PowerNap
- 5. How to connect..... 18
  - 5.1 Connect to a desk phone with a headset port
  - 5.2 Connect to a desk phone without a headset port
  - 5.3 Connect to a USB desk phone
  - 5.4 Connect to a computer
  - 5.5 Connect headset to a computer
  - 5.6 Pair to a mobile device, or mobile devices, using Bluetooth
  - 5.7 Pair to a mobile device using NFC

Headset  
Adviser

2018 GN Audio A/S. All rights reserved. Jabra® is a trademark of GN Audio A/S. The Bluetooth® word mark and logos are registered trademarks owned by the Bluetooth SIG, Inc. and any use of such marks by GN Audio A/S is under license.

Made in China  
MODEL: WHB050BS  
WHB050HS  
WHB051HS



**Declaration of Conformity** can be found on  
[www.jabra.com/doc](http://www.jabra.com/doc)

6. How to use .....	25
6.1 Stereo/Mono headset overview	
6.2 Convertible headset overview	
6.3 Base overview	
6.4 Base status icons	
6.5 How to change language	
6.6 How to adjust the microphone volume for desk phone calls	
6.7 How to reset	
7. How to make calls .....	32
7.1 Basic call usage	
7.2 Merge calls	
7.3 Conference calls	
7.4 Transfer a call from desk phone to headset	
7.5 Transfer a call from headset to desk phone	
7.6 Transfer a call from mobile device to headset	
7.7 Multiple call handling	
8. How to change settings .....	42
8.1 Basic settings	
8.2 Advanced settings	
9. Jabra Direct.....	51
9.1 Firmware update	
10.Support.....	52
10.1 FAQ	
10.2 How to care for your device	
10.3 Replacement accessories	

# 1. Welcome

Thank you for using the Jabra Engage 75. We hope you will enjoy it!

## ***Jabra Engage 75 features***

- **Control all your devices**  
Desk phone, computer, mobile device
- **Pick your wearing style**  
Earhook, neckband, headband
- **World's lightest DECT headset**  
Convertible headset
- **Avoid disturbances**  
Built-in Busylight
- **Use all day long**  
Up to 13 hours talk time (stereo/mono)  
Up to 9 hours talk time (convertible)
- **Take calls anywhere in the office**  
Up to 150 meters/490 feet range (stereo/mono)  
Up to 100 meters/325 feet range (convertible)
- **Secure confidential calls**  
DECT AES 256 bit encryption

## 2. What's in the box

The Jabra Engage 75 comes with one of three different headset styles: stereo, mono, and convertible.

### 2.1 Stereo variant

---

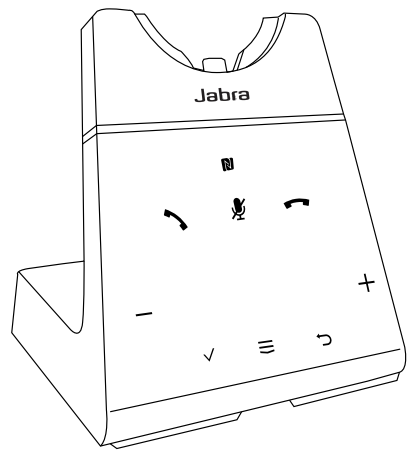

Base



Stereo headset

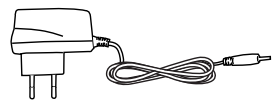

Power cable



Micro-USB cable

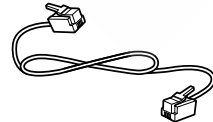

Telephone cable

### 2.2 Mono variant

---

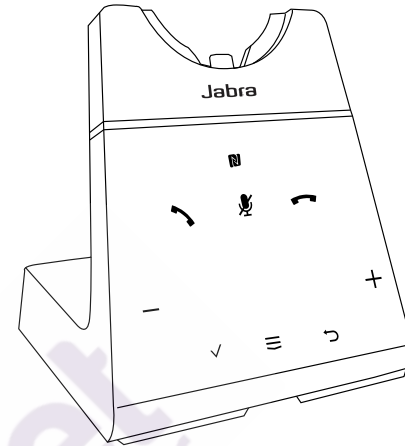

Base

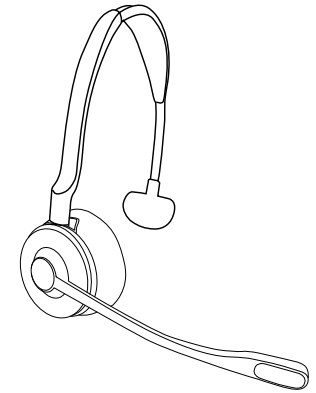

Mono headset

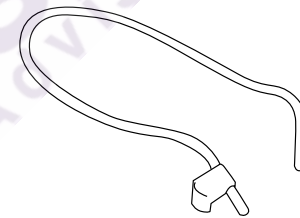

Neckband

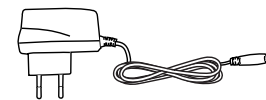

Power cable



Micro-USB cable

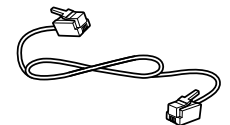

Telephone cable

## 2.3 Convertible variant

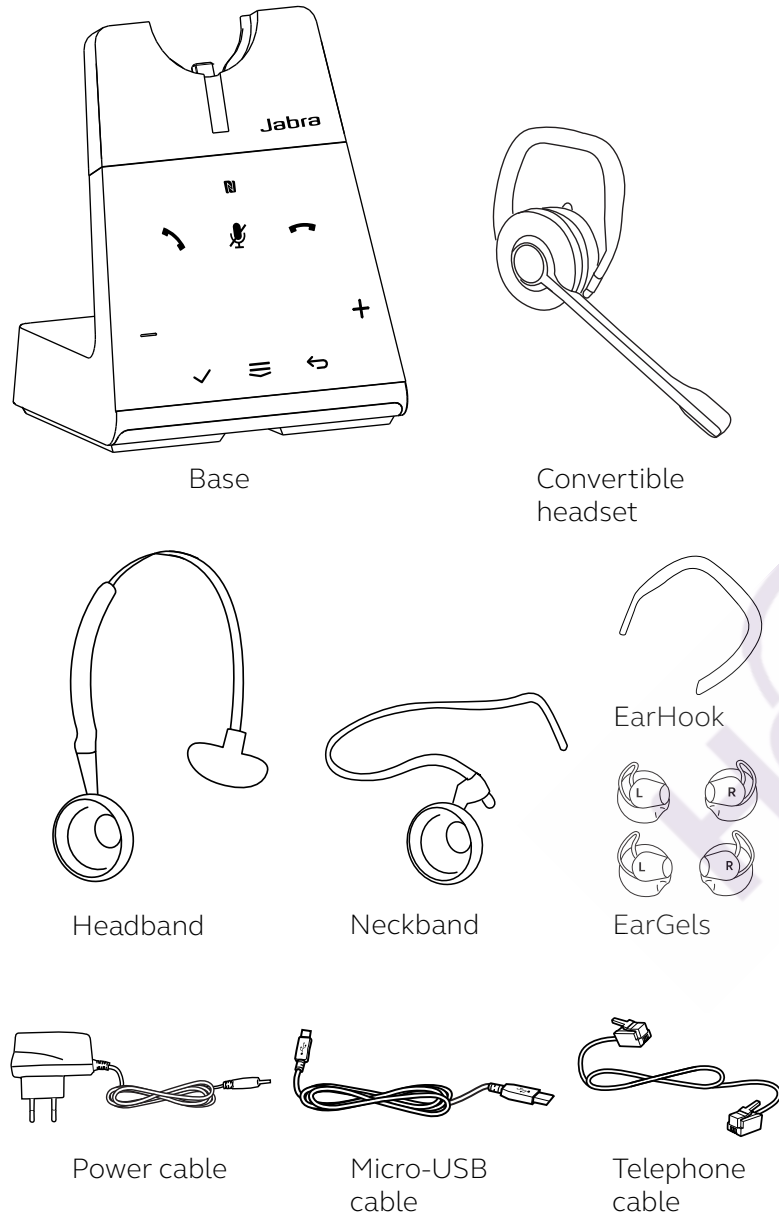

## 3. How to wear

### 3.1 Stereo/Mono headset

The headset can be worn with the microphone on the left or the right.



### 3.2 Convertible headset

---

The headset can be worn on the left or the right ear.

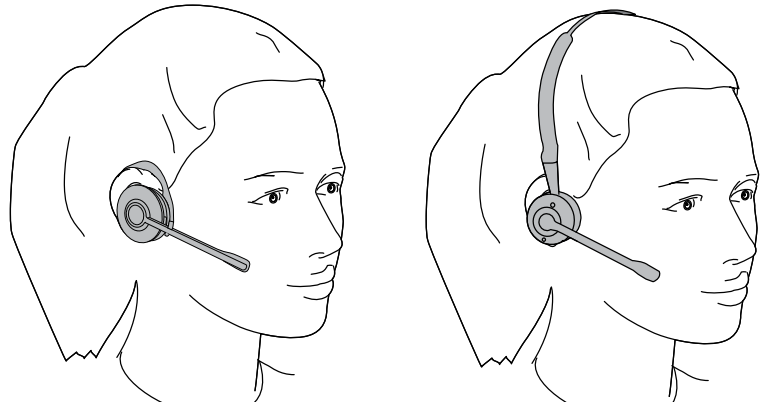

EarHook

Headband

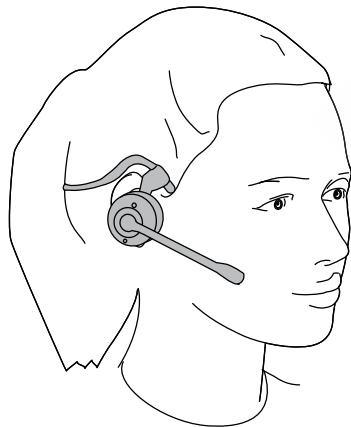

Neckband

### 3.3 How to change mono headset wearing styles

---

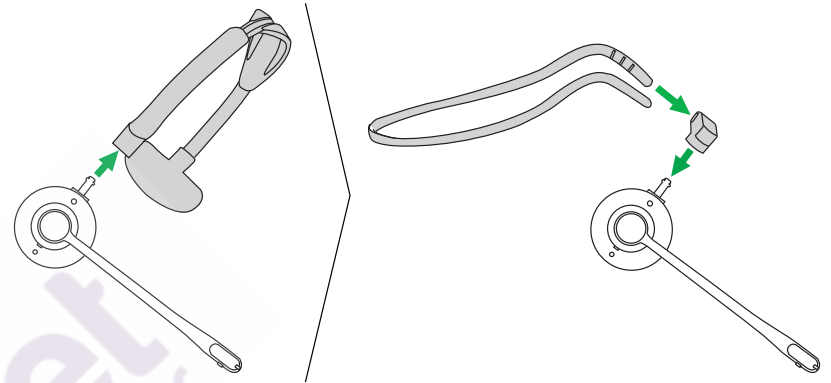

### 3.4 How to change the convertible headset EarGels

---

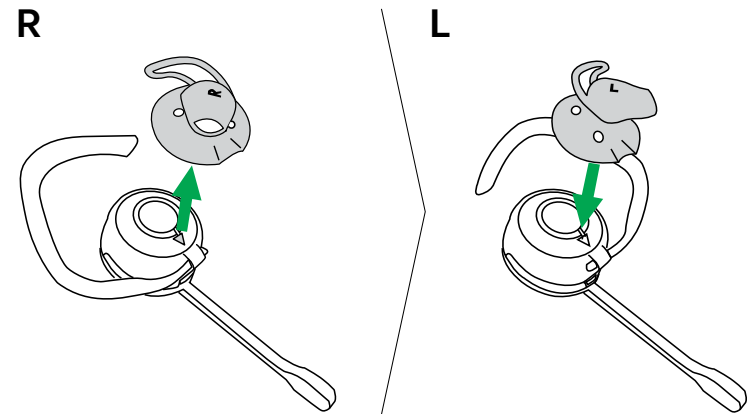
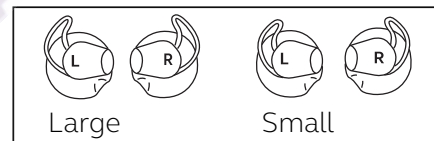

### 3.5 How to change the convertible headset EarHook

---

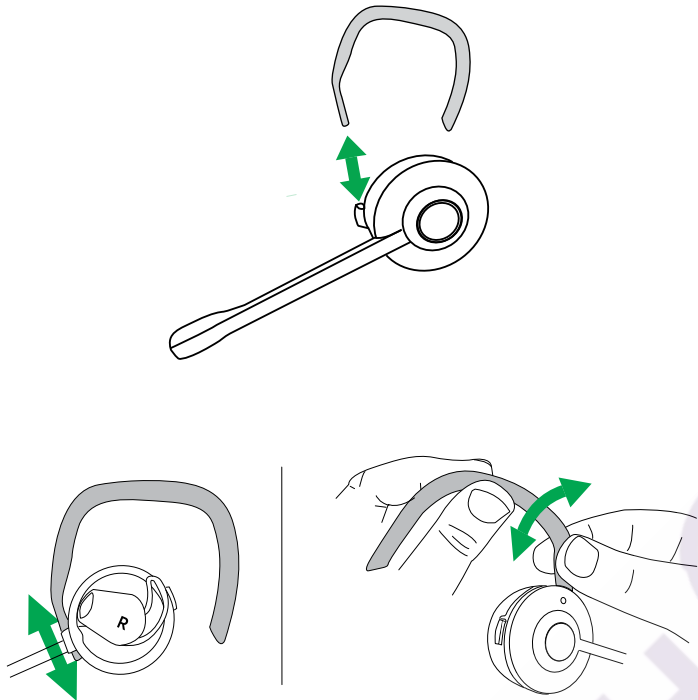

The EarHooks are flexible, and can be bent to suit your ear for a secure and comfortable fit.

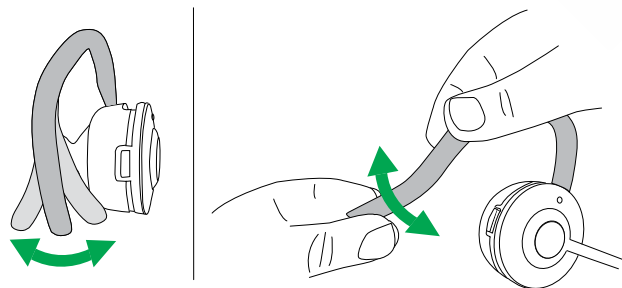

### 3.6 How to change the convertible headset wearing style

---

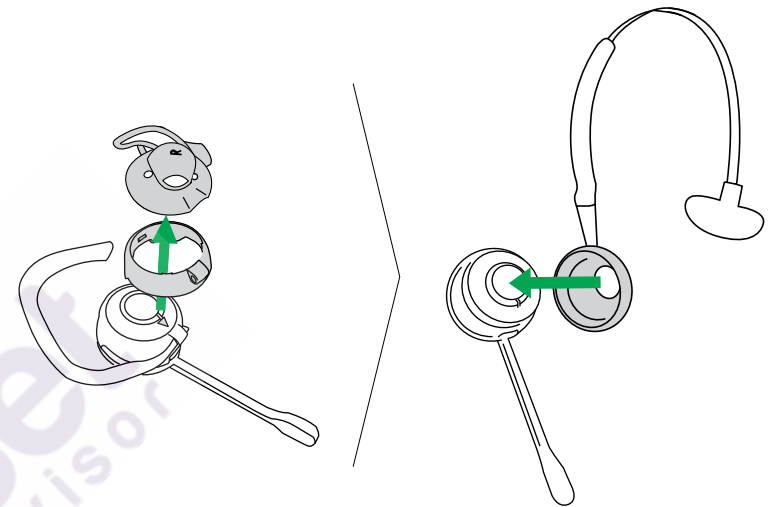

## 4. How to charge

### 4.1 Connect to power

---

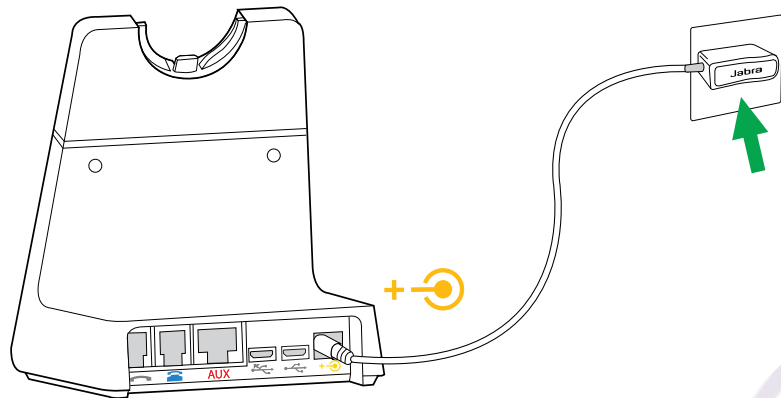

Plug the base into a power supply using the supplied power cable.

It is recommended to connect the telephone or computer cables before connecting the base to a power supply (see Chapter 5 for more information).

### 4.2 Charge the headset

---

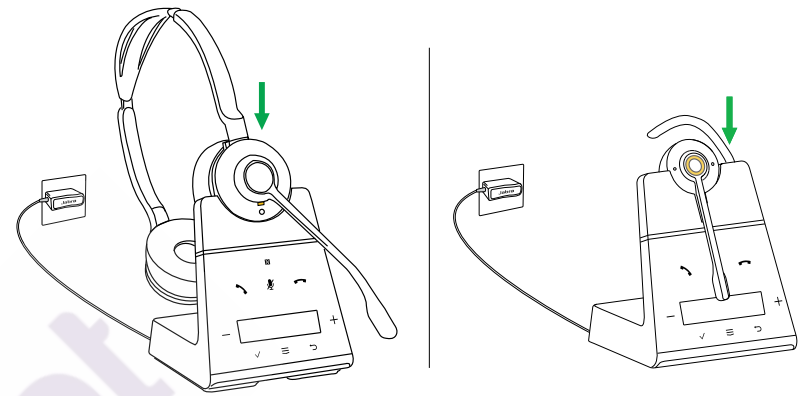

The headset will charge whenever it is docked in a base that is connected to a power supply. The status LED on the headset and the battery icon on the base will pulse to indicate the headset is charging.

The stereo/mono headsets have up to 13 hours of battery, and the convertible headset has up to 9 hours of battery.

All headsets take approx. 1.5 hours to fast charge to full. 40% of the battery will charge in approx. 30 minutes.



## 4.3 Headset PowerNap

---

To conserve battery, the headset will automatically power off when it has not been docked for 30 minutes, has not been moved, and is not in use.

To end PowerNap, either move the headset (the headset has built-in motion sensors), press any button on the headset, or dock the headset in the base.

PowerNap can be permanently turned off using Jabra Direct.

## 5. How to connect

### 5.1 Connect to a desk phone with a headset port

---

This type of desk phone has a dedicated headset port. These phones typically have a button on the front panel for switching between the desk phone handset and the headset.

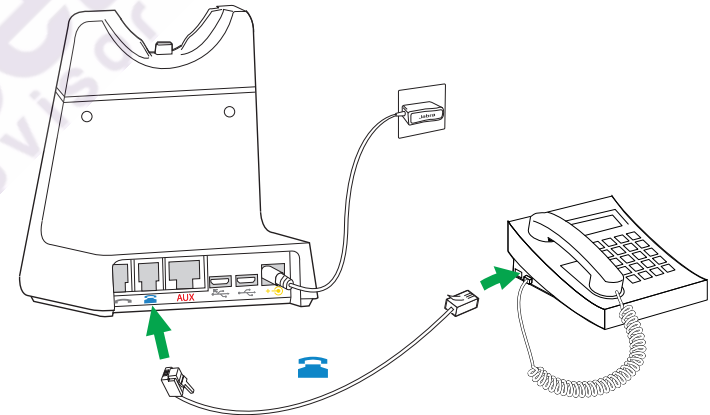

1. Plug the supplied telephone cable into the port marked  on the base, and into the headset port on the desk phone.
2. Plug the base into a power supply using the supplied power cable.
3. Select a language on the base, and then start the setup wizard.



Note: For more assistance for your specific desk phone, visit [www.jabra.com/compatibilityguide](http://www.jabra.com/compatibilityguide).

## 5.2 Connect to a desk phone without a headset port

---

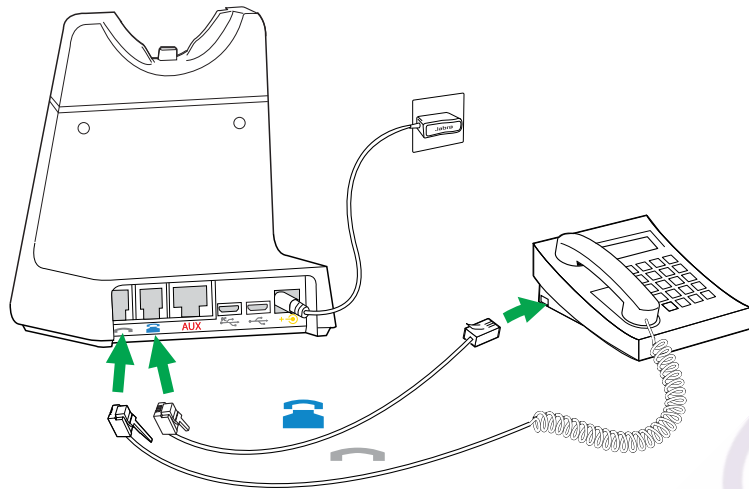
This type of desk phone does not have a dedicated headset port.





1. Unplug the handset cable from the handset port on the desk phone, and plug it into the  port on the base.
2. Plug the supplied telephone cable into the port marked  on the base, and into the handset port on the desk phone.
3. Plug the base into a power supply using the supplied power cable.
4. Select a language on the base, and then start the setup wizard.

Note: For more assistance for your specific desk phone, visit [www.jabra.com/compatibilityguide](http://www.jabra.com/compatibilityguide).

## 5.3 Connect to a USB desk phone

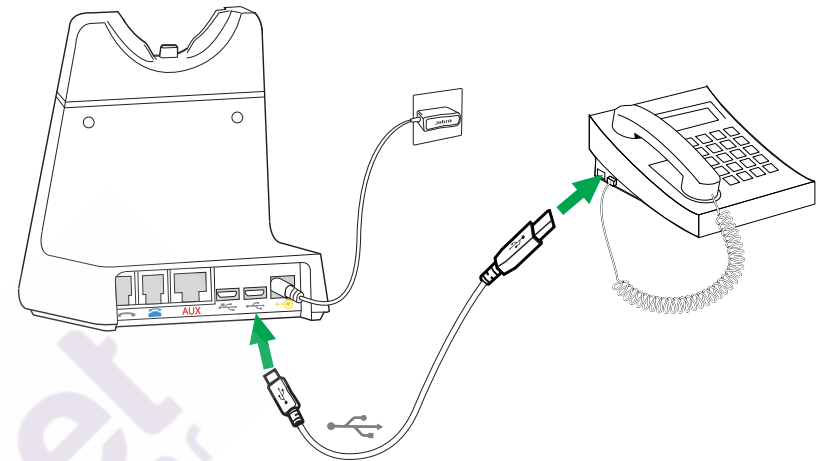
---



1. Plug a micro-USB cable into the port marked  on the base, and into an available USB port on your USB desk phone.
2. Plug the base into a power supply using the supplied power cable.
3. Select a language on the base, and do not start the setup wizard. The base is already configured for USB desk phones and does not require the setup wizard.

## 5.4 Connect to a computer

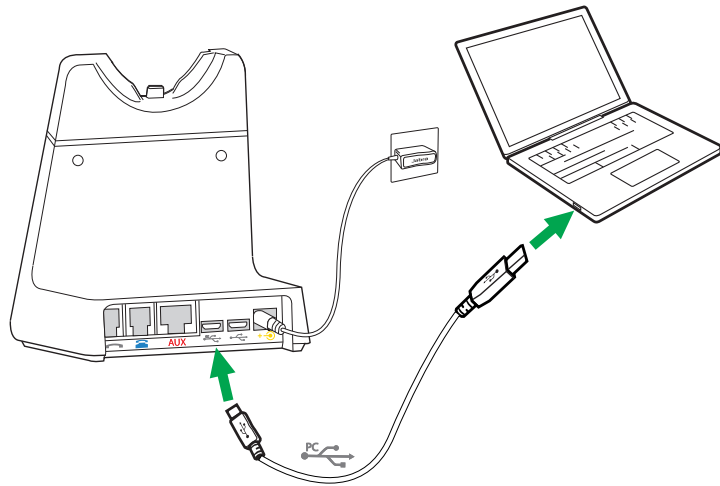

1. Plug the supplied micro-USB cable into the port marked  on the base, and into an available USB port on your computer.
2. Plug the base into a power supply using the supplied power cable.
3. Select a language on the base, and do not start the setup wizard. The base is already configured for computers and does not require the setup wizard.
4. Ensure the Jabra Engage 75 is set as the default playback device and recording device in your operating system's sound settings, and/or your preferred softphone (e.g. Skype for Business). It is recommended to download and install Jabra Direct from [jabra.com/direct](http://jabra.com/direct).

## 5.5 Connect headset to a computer

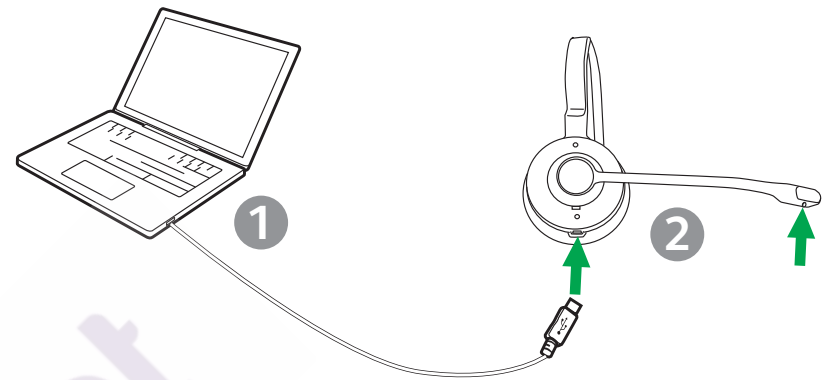





1. Plug the supplied micro-USB cable into an available USB port on your computer.
2. Press and hold either the Volume up, or Volume down, or Mute button on the headset while plugging the other end of the micro-USB cable into the headset. Once the LED on the headset stops flashing green, release the button.
3. The headset can now be selected as an audio playback device on the computer.

## 5.6 Pair to a mobile device, or mobile devices, using Bluetooth

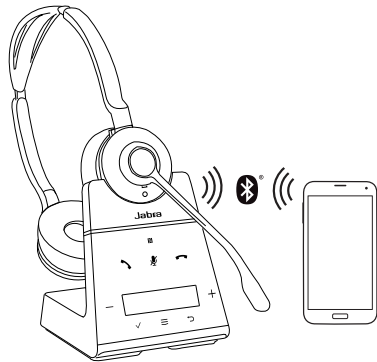
---

It is possible to pair and connect to two mobile devices.



1. Plug the base into a power supply using the supplied power cable.
2. Tap  to open the Settings menu, and tap  to navigate down to **Mobile device**.
3. Tap  to select **New**. Follow the onscreen pairing instructions to pair your mobile device to the headset.

After pairing, the headset and base will automatically connect to your mobile device whenever the mobile device is turned on, within range of the base, and has Bluetooth enabled.

Note: Pairing to a third mobile device will replace the pairing of one of the previously paired mobile devices, so long as one of those mobile devices is currently not connected to the base.

## 5.7 Pair to a mobile device using NFC

---

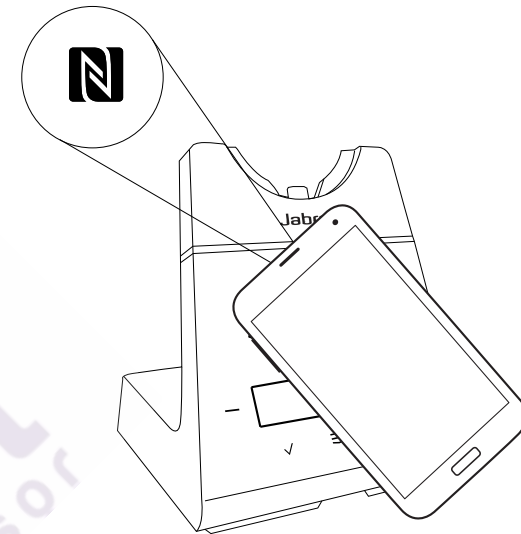

1. Plug the base into a power supply using the supplied power cable.
2. Ensure NFC is enabled on your mobile device.
3. Hold the mobile device against the NFC logo on the base, and follow the instructions on your mobile device to complete the pairing.

After pairing, the headset and base will automatically connect to your mobile device whenever the mobile device is turned on, within range of the base, and has Bluetooth enabled.

Note: The specific NFC location on the mobile device may vary. Refer to the user manual for the mobile device for more information.

## 6. How to use

### 6.1 Stereo/Mono headset overview

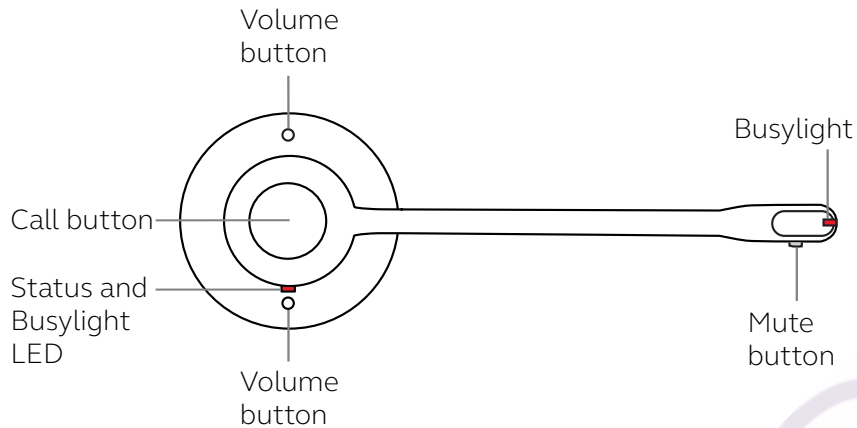

### 6.2 Convertible headset overview

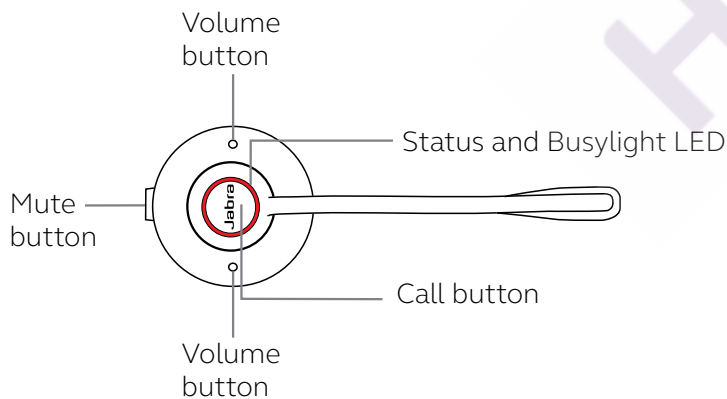

### 6.3 Base overview

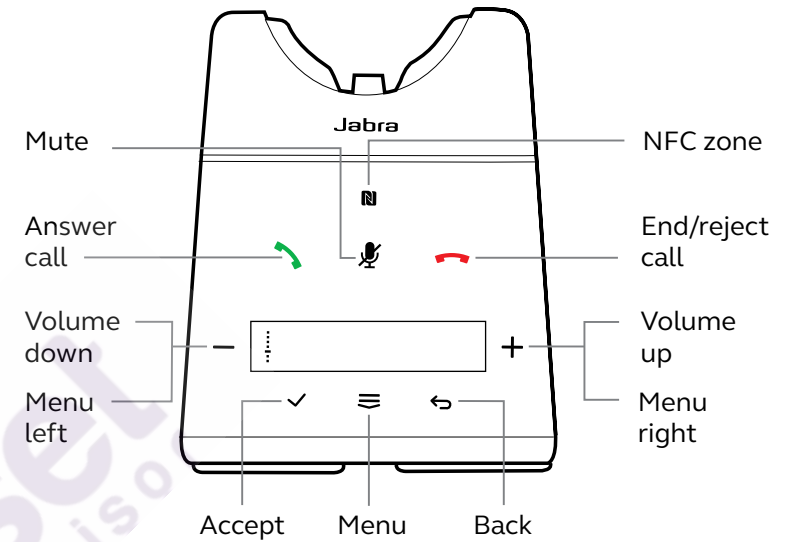

### 6.4 Base status icons

Icon	Description
	Battery status
	Unknown battery status
	Headset connected
	(blinking) Headset not detected
	Two headsets in conference mode

**Questions?  
Click to Live Chat**

**3x📞** Three headsets in conference mode

**4x📞** Four headsets in conference mode

 Mobile device

 Desk phone

 Computer

 Second mobile device

 Paired mobile device not connected

 Target phone

 Call on target phone

 Held call

**>>> 📞 <<<<** Incoming call on mobile device

**>>> 📞 <<<<** Incoming call on desk phone

**>>> 🖥️ <<<<** Incoming call on computer

**>>> 📱 <<<<** Incoming call on second mobile device

**> Caller ID <** Incoming call with caller id

## 6.5 How to change language

---









### **Onscreen text**

There are 16 available languages for the onscreen text: English, German, French, Chinese (simplified), Spanish, Czech, Danish, Dutch, Finnish, Hungarian, Italian, Norwegian, Polish, Russian, Swedish, and Turkish.

### **Headset voice announcements**

There are 5 available languages for the headset voice announcements: English, German, French, Japanese, and Spanish.

To change language:





1. Tap  to open the Settings menu, and tap  to navigate down to **Language**.
2. Tap  or  to switch between **Text** or **Voice**, and then tap  to confirm your choice.
3. Tap  or  to cycle through the available languages, and then tap  to confirm your choice.

Note: When choosing a voice language, if **Follow text** is selected and the current text language is not one of the 5 available voice languages, the voice language will default to **English**.

## 6.6 How to adjust the microphone volume for desk phone calls

---

To adjust the desk phone microphone volume:







1. Tap  on the base to open the Settings menu.
2. Tap  or  to adjust the desk phone microphone volume, and then tap  to confirm your choice.

The microphone volume can be adjusted while you are on a call, however the microphone volume will reset to the default level when the call ends.

## 6.7 How to reset





Resetting the headset and the base clears the list of paired devices and resets all settings.

To reset:

1. Dock the headset in the base.
2. Hold  for 2 seconds to open the Advanced settings menu.
3. Tap  to select **Base**, and then tap  to confirm your choice.
4. Tap  to navigate down through the settings until **Reset configuration** is selected.
5. Tap  to select **Yes**, and then tap  to confirm your choice. The headset and base will reboot and all settings will return to their default values.

## 7. How to make calls

### 7.1 Basic call usage

Function	Action
Power on	Press the <b>Call</b> button on the headset, or dock the headset in the base
Power off	Hold the <b>Call</b> button for 4 seconds
Answer call	Press the <b>Call</b> button, undock the headset, or tap  on the base
End call	Press the <b>Call</b> button, dock the headset, or tap  on the base
Reject call	Double-press the <b>Call</b> button, or tap  on the base
Switch target phone	Undock the headset and hold the <b>Call</b> button for 1 second  Alternatively, hold  on the base for 1 second

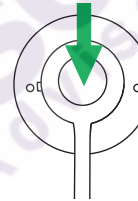



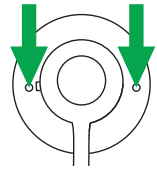

Adjust volume

Press the **Volume** buttons.

The headset uses motion sensors to detect which button is volume up and which is volume down, depending on the headset orientation

Toggle  
Busylight

Press both **Volume** buttons at the same time

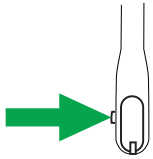

Mute/un-mute  
microphone

Press the **Mute** button (stereo/mono headset)

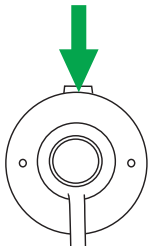



Mute/un-mute  
microphone

Press the **Mute** button (convertible headset)

## 7.2 Merge calls

It is possible to merge an incoming call with a current call.

To merge calls:

1. Hold the **Call** button (2 secs) on the headset, or tap  on the base, to accept the incoming call. This will place the current call on hold.
2. Tap  and select **Yes** to merge the calls.

To unmerge the calls, tap  and then select **Yes** to unmerge the calls.

To end the merged call, dock the headset or press the **Call** button on the headset.

## 7.3 Conference calls

### Add headset(s) to a conference call

Up to three additional headsets can be connected to one base for conferencing.

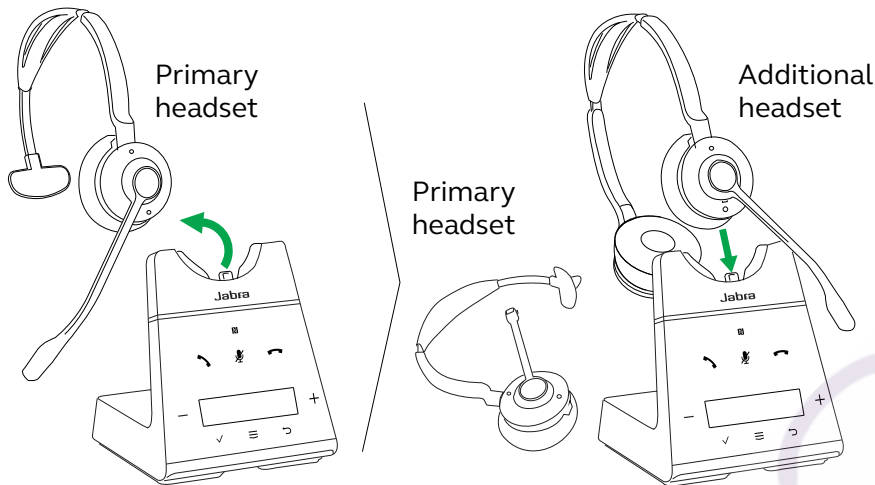

1. Undock the primary headset.
2. Dock an additional headset in the base.
3. Tap ✓ to add the headset as an additional conference headset.
4. A voice prompt will play in the primary headset. Press the **Call** button on the primary headset to accept the additional headset to the conference. The audio will now be shared between headsets.

By default, the additional headset will be muted.

Note: It is possible to use Jabra Engage 65 headsets for conference calls.

### Add headset(s) to a conference call without docking

Up to three additional headsets can be connected to one base, without the need to dock the headsets.

1. Tap ☰ on the base to open the settings menu, and navigate to **Add headset**.
2. Tap + to switch to **Pair without docking**.
3. Tap ✓ to put the base into pairing mode.
4. Power off the additional headset by holding the **Call** button for 4 seconds.
5. Put the additional headset into pairing mode by holding the **Call** button for 5 seconds until the status LED on the headset flashes blue.
6. A voice prompt will play in the primary headset. Press the **Call** button on the primary headset to accept the additional headset, to the conference. The audio will now be shared between headsets.

By default, the additional headset will be muted.

Note: It is possible to use Jabra Engage 65 headsets for conference calls.

### ***End or leave a conference call***

To end the call for all headsets, press the **Call** button on the primary headset, or dock the primary headset in the base.

Additional headsets can leave the conference by pressing the **Call** button on the headset, or by docking the additional headset in the primary headset's base (not the additional headset's base). The conference call will continue for all other headsets.

### ***Permanent conference mode***

By default, the conference will end automatically for all additional headsets when the call ends.

It is possible to continue the conference with the additional headsets until the primary headset is docked, by changing this setting in Jabra Direct.

### 7.4 Transfer a call from desk phone to headset

---

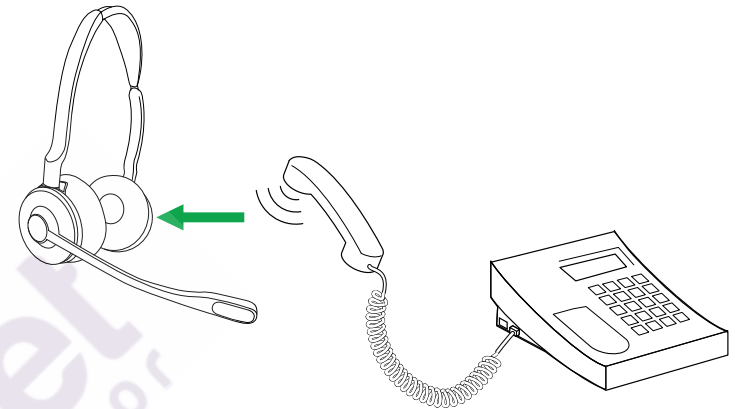

To transfer a call:

1. Select the desk phone as the target phone on the base.
2. Lift the headset from the base, or tap the **Call** button on the headset. If necessary, press the headset button on the desk phone. The audio will transfer from the desk phone handset to the headset.

Do not hang up the desk phone handset until the call is finished.

## 7.5 Transfer a call from headset to desk phone

---

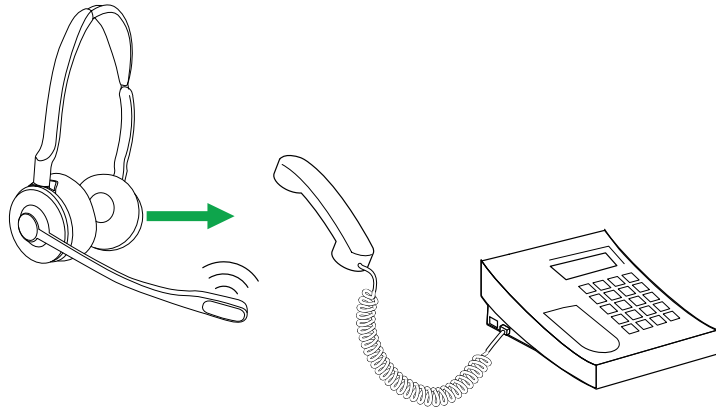

To transfer a call from the headset to a desk phone, lift the desk phone handset and then dock the headset in the base.

The audio will transfer from the headset to the desk phone.

## 7.6 Transfer a call from mobile device to headset

---

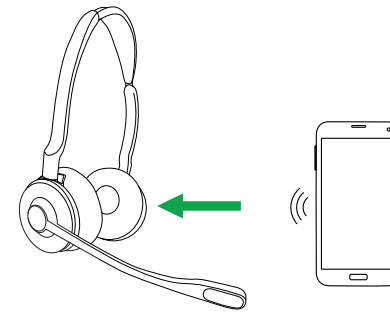

To transfer a call:

1. Select the mobile device as the target phone on the base.
2. Lift the headset from the base, or tap the **Call** button on the headset.
3. Select **Yes** on the base to transfer the call audio to the headset.

Do not end the call on the mobile device until the call is finished.

## 7.7 Multiple call handling

---

The headset and base can accept and handle multiple calls at the same time.

### Multiple call handling

Answer incoming call and put current call on hold Tap  on the base

Switch between held call and active call Tap  on the base

Reject incoming call, while on a current call Tap  on the base

## 8. How to change settings

Headset, base, phone, and general settings can be changed on the base using the Basic settings menu, or the Advanced settings menu.

Alternatively, all settings can be changed using Jabra Direct on your computer. Jabra Direct can be downloaded at [jabra.com/direct](http://jabra.com/direct).

### 8.1 Basic settings

---

Tap  to access the Basic settings menu.

#### Desk phone microphone

Volume controls Tap + or - to adjust the desk phone microphone volume

#### Add headset settings

How to View instructions on how to add a new headset to the base

Pair without docking Select to put the base into pairing mode, and then view instructions on how to pair a headset to the base without docking the headset

Conference Select the method to use for ending conference calls

**Mobile device settings**

New	View instructions on how to pair the headset/base to a mobile device
Devices	View a list of paired mobile devices
Disconnect	Select to disconnect all paired mobile devices
Delete pairing	Select to unpair all mobile devices

**Language settings**

Text	Select the screen text language from a list of 16 languages
Voice	Select the headset voice language from a list of 5 languages

**Ringtone settings**

Desk phone	Select a ringtone and ringtone volume for incoming desk phone calls
USB desk phone	Select a ringtone and ringtone volume for incoming USB desk phone calls
Softphone	Select a ringtone and ringtone volume for incoming softphone calls
Mobile device	Select a ringtone and ringtone volume for incoming mobile device calls

**Screen settings**

Idle screen	Select what should be displayed on the base when it is not in use
Brightness	Select the brightness of the screen and the screensaver

**Clock settings\***

Hour format	Select the clock format
Set	Set the time

\*Only available when **Synchronize clock with computer** is set to **Off** in Jabra Direct.



## 8.2 Advanced settings

Hold  (2 secs) to access the Advanced settings menu.

Headset settings	
Equalizer for calls	Select an audio preference to use for all calls
Optimize audio for music	Select to optimize the audio for music, or to optimize for battery performance and reduced density issues
Audio announcements	Select the audio announcement type
Audio protection	Select the level of audio protection to be used. The headset always provides protection against sound spikes, ensuring that your hearing is always protected, regardless of the setting selected
Audio bandwidth	Select the audio bandwidth type. Wideband provides better audio, and narrowband provides better battery life
Mute reminder	Select to use a periodic audio reminder when the microphone is muted

Sidetone	Select the volume level used for Sidetone. Sidetone refers to audio from the microphone that is reproduced in the headset, enabling you to hear your own voice. Sidetone does not affect the volume level of your voice that other people will hear
Voice language	Select the headset voice announcement language
Busylight	Select to enable or disable the headset busylight
Headset conferencing	Select to enable headset conferencing mode, allowing the connection of multiple headsets to the same call
Pair without docking	Select to enable pairing of a headset without docking it
PowerNap	Select to enable sleep mode when the headset has not been docked for 30 minutes, and has not been moved, and is not in use

Base settings	
Button feedback volume	Select the volume level of the sound made when you tap the buttons on the base
Screen brightness	Select the brightness level of the screen and the screensaver
Wireless signal range	Select the wireless range between the headset and base
Record call	Select to enable calls from mobile devices or desk phones to be recorded on your computer. The supplied USB cable needs to be connected between the base and the computer, and third party recording software is required
Merge call	Select to enable call merging, allowing multiple ongoing calls to participate in the same conversation
Call priority	Select which call takes priority when a second call is accepted, without interaction on the base (e.g. a second phone call was accepted on the phone).
Phone for outgoing call	Select which phone to use for outgoing calls

Answer call on undock	Select to enable incoming calls to be answered by undocking the headset
Simultaneous ring	Select which incoming call is displayed, if several connected phones ring simultaneously
PowerNap	Select to enable sleep mode if the base has been idle for 10 hours
Base name	View the base name. The base name and/or headset name can be changed using Jabra Direct
Reset configuration	Select to reset the headset and base to their default configuration
Softphone settings	
	Select <b>Yes</b> to open the Advanced softphone settings menu
Start setup	Tap  to navigate down through the available softphone settings
	Press  to accept any changes made to the settings. The base will reboot



### Desk phone settings

Select **Yes** to open the Advanced desk phone settings menu

Start setup

Tap  to navigate down through the available desk phone settings

Press  to accept any changes made to the settings. The base will reboot

### USB desk phone settings

Select **Yes** to open the Advanced USB desk phone settings menu

Start setup

Tap  to navigate down through the available USB desk phone settings

Press  to accept any changes made to the settings. The base will reboot

### Mobile device settings

Select **Yes** to open the Advanced Mobile device settings menu

Start setup

Tap  to navigate down through the available mobile device settings

Press  to accept any changes made to the settings. The base will reboot

### Product information

Tap  to navigate down through the list of product information

## 9. Jabra Direct

Jabra Direct is computer software designed to support, manage, and enable optimal functionality for your Jabra devices.

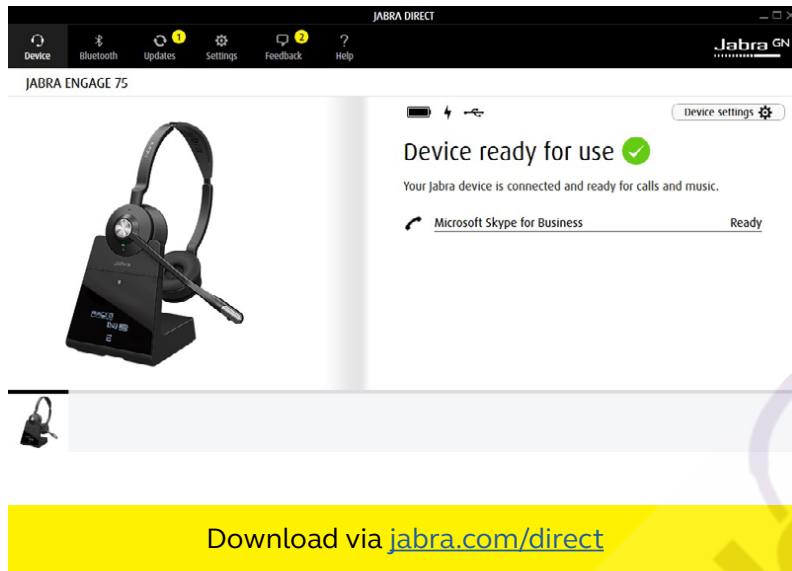

### 9.1 Firmware update

Jabra Direct will notify you when there is a firmware update available.

## 10. Support

### 10.1 FAQ

---

View the FAQs on [jabra.com/engage](https://jabra.com/engage).

### 10.2 How to care for your device

---

- It is recommended to keep the headset between -5°C and 45°C (23°F and 113°F).
- Do not store the headset for extended periods of time without recharging the battery (max. three months).
- If the headset or base becomes dirty, it is recommended to clean them with a soft, lint-free cloth that has been dampened with clean water.

### 10.3 Replacement accessories

---

Replacement or additional accessories can be purchased online at [jabra.com/accessories](https://jabra.com/accessories).

**Questions?  
Click to Live Chat**

Headset  
Advisor