

# Hydraulic MultiScoop (MSC-H)

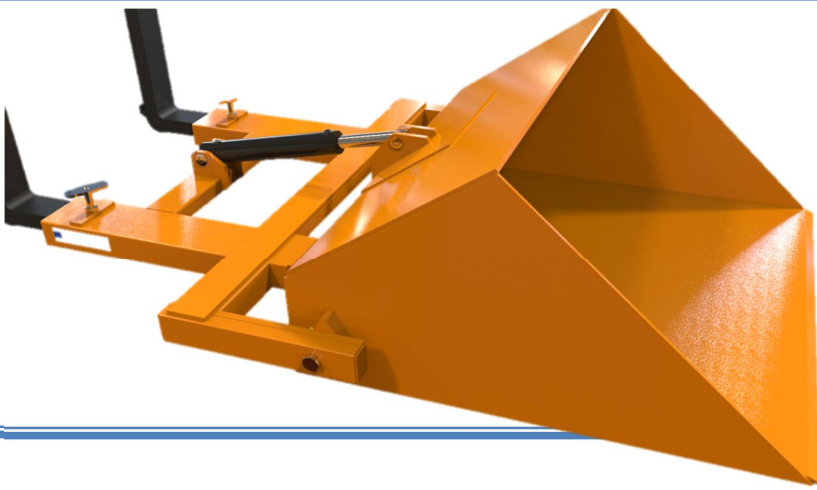

When filling material such as sand or aggregate from a substantial heap, the attachment should not be driven directly into the heap. The approach should be at ground level, but the mast should be slowly raised as the truck is driven forwards, so that the bucket runs up and fills off the angled face of the heap. This reduces wear and tear on the mast bearings etc. Ensure when loading that the material fills right to the back of the bucket.

Maximum Fork Size 125 x 40 mm

Max Fork Spread 886mm

The Ideal scoop for loading small vans and charging hoppers. Hydraulically operated.

Long reach allows discharge of materials into centre of lorry, whilst small tipping arc allows discharge where headroom is confined. Calibrated model also available, ideal for point of sale measurement and loading of loose material.

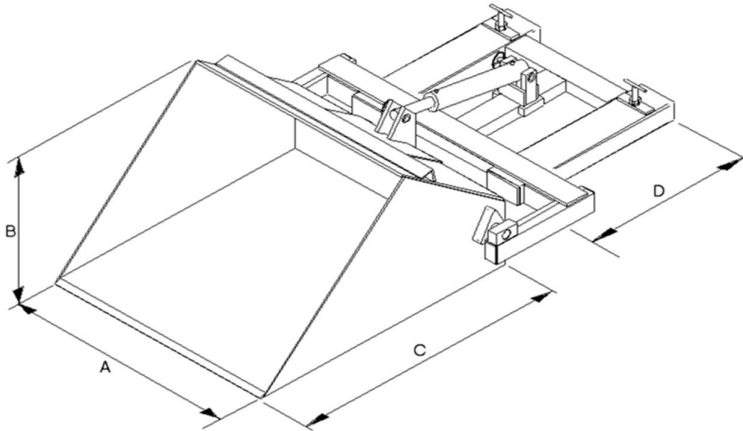

Model Ref.	Weight	C of G Min	C of G Max	Load Centre
MSC 20H	190Kg	750mm	1080mm	1220mm
MSC 40H	205Kg	790mm	1120mm	1220mm
MSC 50H	350Kg	820mm	1150mm	1220mm

Model Ref.	Volume	Capacity	A (Bucket Height)	B (Bucket Width)	C (Bucket Length)	D (Pocket Length)
MSC 20H	0.20m <sup>3</sup>	300Kg	505mm	800mm	930mm	750mm
MSC 40H	0.40m <sup>3</sup>	600Kg	608mm	1000mm	1170mm	750mm
MSC 50H	0.50m <sup>3</sup>	600Kg	608mm	1250mm	1170mm	750mm