



William Hackett



Lifting365

WH GT Corrosion Protected Geared Trolley

The William Hackett WH GT Corrosion Protected Geared Trolleys meet and exceed the requirements of the following international standards: British Standard BS EN 13157:2004 + A1:2009.

This high quality trolley range is precision engineered in WLL capacities from 500kg to 5 tonnes.

Enabling exact positioning or easy traversing of large loads incorporating Manual hoists, the William Hackett series geared trolley can be supplied to suit various track widths with beam range 1 and the extended beam range 2.

It has been designed so that the bottom of the hand chain loop is located approximately 500mm from ground level.

The runners (trolley wheels) are precision machined and they rotate on maintenance sealed ball bearings.

All William Hackett geared trolleys are fitted with anti-jump bars rubber end stops as standard.



Specifications

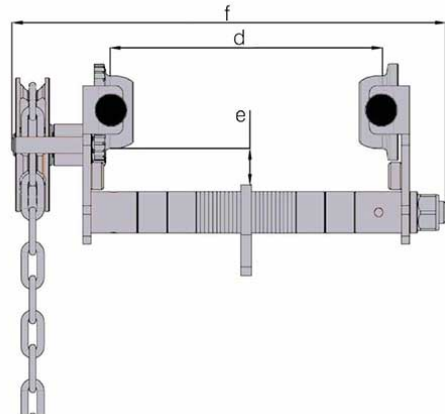
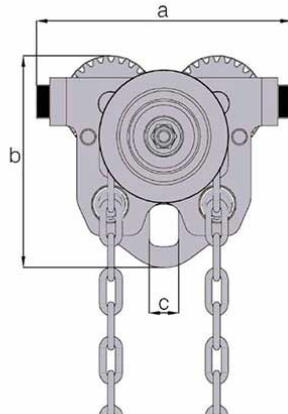

Part Code	WLL t	Min.radius of Curve m	a mm	b mm	c mm	e mm
055.050.CP	0.50	0.8	190	154	22	27
055.100.CP	1.00	0.9	206	180	30	26
055.200.CP	2.00	1.0	246	210	37	26
055.320.CP	3.20	1.2	300	249	42	28
055.500.CP	5.00	1.3	336	277	50	37

Standard Range 1

WLL t	I Beam Width mm	d Max. width mm	f Max. mm	Mass kg
0.50	50-203	203	323	9.60
1.00	64-203	203	332	12.30
2.00	88-203	203	341	17.20
3.20	100-203	203	359	28.40
5.00	114-203	203	366	40.10

Extended Range 2

WLL t	I Beam Width mm	d Max. width mm	f Max. mm	Mass kg
0.50	-	-	-	-
1.00	64-305	305	434	13.70
2.00	88-305	305	443	19.00
3.20	100-305	305	461	31.20
5.00	114-305	305	468	44.20