

## Load indicators

Measuring range: 0 - 20 tonne

The Tigrip load indicators, TZL and TZR, are compact measuring devices for the weighing of loads. The TZL model is the standard digital display unit and the TZR model comes complete with a radio remote control.

On account of their flexibility, these load indicators are suitable for a multitude of applications. Whether used as a conventional crane weigher or to measure forces, it is the economical choice for various applications. They are very simple and straight forward to use!

The load indicators have a liquid crystal display (LCD), which can tare as well as show either the gross or the net load. It also indicates overload at 110% of the rated capacity and the status of the battery.

### Model: TZL (WITHOUT remote control)

#### Features and benefits include:

- ✓ High accuracy.
- ✓ Lightweight design.
- ✓ Easy-to-read display.
- ✓ Easy to use.
- ✓ Robust design.
- ✓ Retains the peak value to memory.
- ✓ The battery capacity provides for around 200 operating hours.
- ✓ Automatic setting to zero when load indicator is switched on.
- ✓ Use of rechargeable batteries possible (external battery charger\*).
- ✓ Display of maximum weight (gross/net).
- ✓ Display of measuring units at the load indicator.
- ✓ Measuring units: kg, tonnes, lbs, and kN.
- ✓ Automatic stand-by for a prolonged battery lifetime.
- ✓ Simple change of batteries.
- ✓ Warning, if batteries are low.
- ✓ Overload warning.

#### Included in delivery of TZL:

- ✓ Load indicator.
- ✓ 4 x 1.5 V AA batteries.
- ✓ Test certificate.

**\*NB. External battery charger is not supplied as standard, but must be specified as an optional extra.**



\* Shackles shown in photograph are not supplied as standard.



### Model: TZR (WITH remote control)

The TZR load indicator can be operated by radio control. The displayed values can be taken off the remote control device and can be easily transferred to a PC. The system can be combined with an easy-to-read display. Several measured values can be totalled and saved.

#### TZR has the same features as the TZL model plus:

- ✓ Remote control and data exchange via radio transmission.
- ✓ USB interface.
- ✓ Accumulation memory .

#### Included in delivery of TZR:

- ✓ Load indicator.
- ✓ Remote control with display.
- ✓ 7 x 1.5 V AA batteries.
- ✓ Test certificate.
- ✓ PC cable (RS232).
- ✓ User software.
- ✓ Carrying case.



## TECHNICAL DATA / PRICES

Model	Article number	Measuring range tonne	Nominal load tonne	Limit load tonne	Braking load tonne	Weight without shackles kg	Accuracy of the end value %	Resolution step (partition) kg
TZL 1.0	N53808323	0 - 1	1	1.1	>4	1.1	0.2	1
TZL 2.5	N53808324	0 - 2.5	2.5	2.75	>10	1.7	0.2	1
TZL 5.0	N53808325	0 - 5	5	5.5	>20	2.1	0.2	1
TZL 10.0	N53808326	0 - 10	10	11	>40	3.9	0.2	10
TZL 20.0	N53808327	0 - 20	20	22	>80	6.8	0.2	10
TZR 1.0	N53808331	0 - 1	1	1.1	>4	1.1	0.2	1
TZR 2.5	N53808332	0 - 2.5	2.5	2.75	>10	1.7	0.2	1
TZR 5.0	N53808334	0 - 5	5	5.5	>20	2.1	0.2	1
TZR 10.0	N53808333	0 - 10	10	11	>40	3.9	0.2	10
TZR 20.0	N53808335	0 - 20	20	22	>80	6.8	0.2	10

### Technical data on TZL and TZR:

- Operation time, approximately 200 hours with 4 x 1.5V AA batteries.
- Temperature range when in storage -20°C to +70°C.
- 20.5 mm high LCD display (4.5 digits).
- Overload warning at 110% of the rated capacity.
- Temperature range when in operation -10°C to +50°C.
- IP 54 protection.
- Tare range is 100% of rated capacity.

## DIMENSIONS

Model	TZL 1.0 TZR 1.0	TZL 2.5 TZR 2.5	TZL 5.0 TZR 5.0	TZL 10.0 TZR 10.0	TZL 20.0 TZR 20.0
A, mm	190	233	250	325	378
B, mm	118	118	118	118	118
C, mm	14	22	27	48	55
D, mm	151	173	180	213	233
E, mm	12.5	19	21.5	22	32
F, mm	37	-	-	-	-
G, mm	21	25	30.5	47	57
H, mm	38.4	42.2	45.1	64.4	74.2
J, mm	348	604	610	690	780
K, mm	30	34	50	105	92
L, mm	26	38	44	95	95
M, mm	10	16	19	35	35
N, mm	25	25	32	50	70
O, mm	23	23	37	63	80
P, mm	17	17	28	44	57
Q, mm	235	309	315	535	562
R, mm	16	-	-	-	-

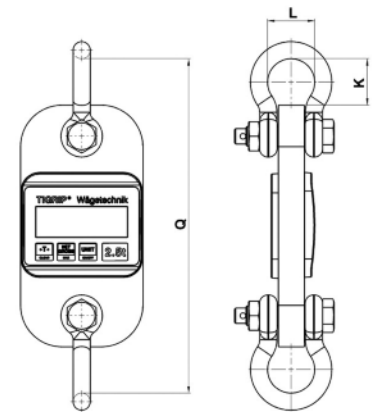

Load indicator.  
Model TZL/TZR with shackle.

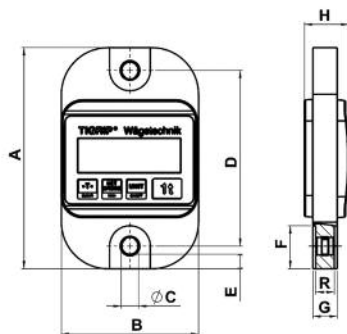

Load indicator.  
Model TZL/TZR 1.0t.

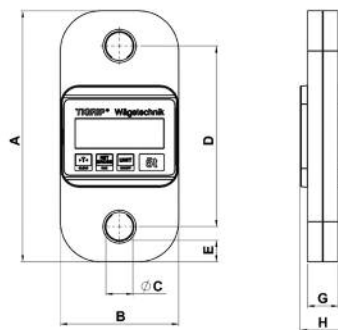

Load indicator.  
Model TZL/TZR 2.5 up to 20t.

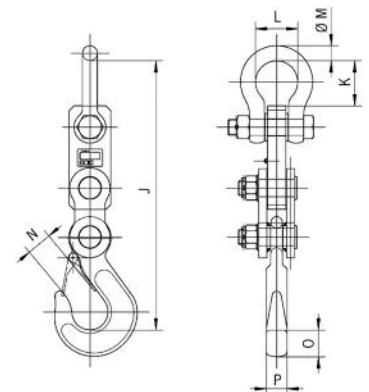

Load indicator.  
Model TZL/TZR with hook.