

# TCR-250 AIR HOIST

 **Lifting365.com**



**RED ROOSTER  
LIFTING**

RAISING EXPECTATIONS

The **TCR-250** is a 250 kg chain hoist from Red Rooster Lifting. This is part of our air hoist hook suspension range for lifting equipment applications in industry. Compact and lightweight.



The **Red Rooster Lifting** TCR series of air hoists offers a comprehensive range of lifting equipment suited to all types of industrial and marine environments. Red Rooster Lifting hoists are the perfect lifting solution for where the duty is high, or where a robust hoist is required to withstand harsh conditions. The hoists comply with the European Machinery Directive and are all CE marked.

## STANDARD FEATURES

- Compact and lightweight body
- ATEX zone 2 specification
- Toku rotary vane motor
- Robust epicycle gearbox
- Failsafe automatic internal disc brake
- Mechanical upper & lower switches
- Aluminium housing
- Internal silencing down to 83 dB(A)
- Alloy safety swivel hooks with safety catch
- Load chain 4 x 12mm of European manufacture to EN818-7

## AVAILABLE OPTIONS

- Marine specification
- Special paint systems
- Corrosion protection
- ATEX zone 1 specification
- Chain collectors (PVC, galvanised or stainless steel)
- Air service units
- Festoon systems
- Radio control
- Main air shut off valve



**ATEX ZONE 2  
AS STANDARD**

 **Lifting365.com**

# TCR-250 AIR HOIST

 Lifting365.com



**RED ROOSTER  
LIFTING**

RAISING EXPECTATIONS

## DIMENSIONS

All measurements are in mm  
Information subject to change without notice

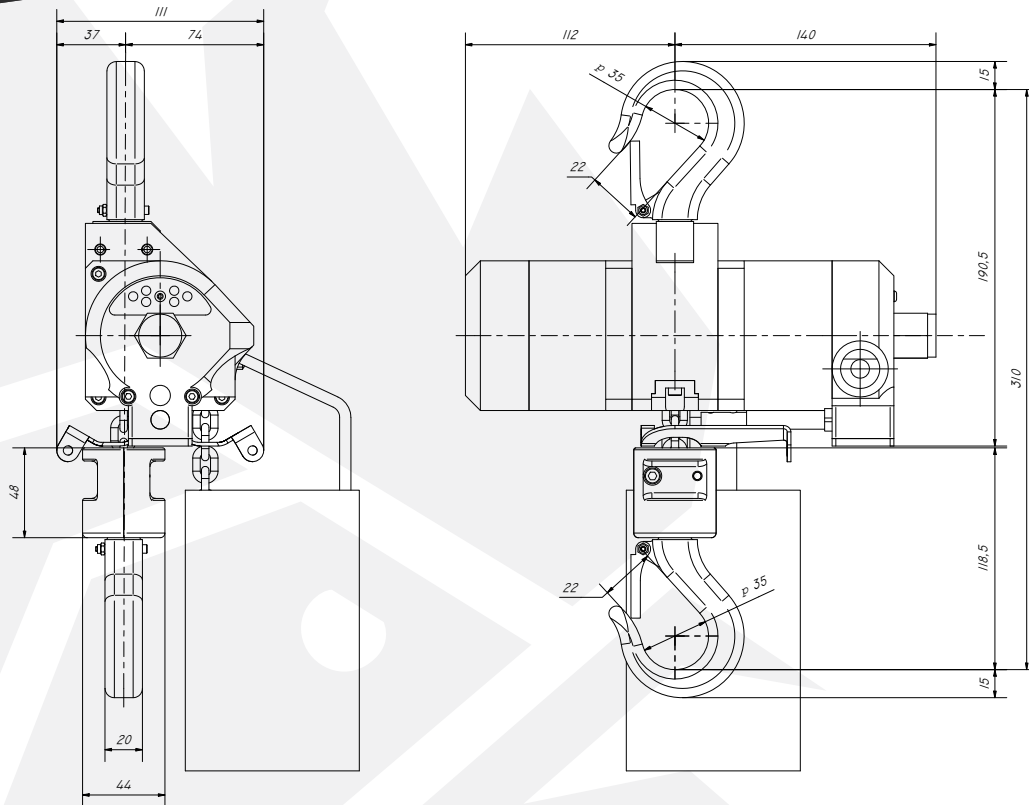

HOIST MODEL	TCR-250
WLL	250 kg
CHAIN FALLS	1
LIFTING SPEED WITH LOAD	9.3 m/min
LIFTING SPEED WITHOUT LOAD	19.0 m/min
LOWERING SPEED WITH LOAD	17.9 m/min
AIR CONSUMPTION LIFTING	13 l/sec
AIR CONSUMPTION LOWERING	15 l/sec
WORKING PRESSURE	6 Bar
AIR CONNECTION	1/2" BSP
MINIMUM HOSE DIA.	1/2"
WEIGHT 3M HOL	7.0 kg
ADDITIONAL METRE HOL	0.35 kg

 Lifting365.com