



Operating Instructions

Translation of original operating instructions

Adjustable Paver Transport Cart

VTK-V

Contents

- 1 EC-Declaration of Conformity 3**
- 2 General..... 4**
 - 2.1 Authorized use..... 4
 - 2.2 Survey and construction 5
 - 2.3 Technical data 6
- 3 Safety 7**
 - 3.1 Safety symbols 7
 - 3.2 Safety Marking..... 8
 - 3.3 Definition skilled worker / specialist 8
 - 3.4 Personal safety requirements 9
 - 3.5 Protective equipment..... 9
 - 3.6 Accident prevention 9
 - 3.7 Function Control..... 9
 - 3.7.1 General 9
 - 3.8 Safety procedures 10
 - 3.8.1 General 10
- 4 Installation.....11**
 - 4.1 Assembly of the VTK-V 11
 - 4.2 Adjusting the VTK-V 11
 - 4.3 Installation of supporting wheel (optional) 12
 - 4.4 Installation of special gripper and wider load support 12
 - 4.5 Installation of insertable storage tray 14
- 5 Operation 15**
 - 5.1 Loads on firm ground 15
 - 5.2 Load on the pallet..... 16
- 6 Maintenance and care 17**
 - 6.1 Maintenance 17
 - 6.1.1 Mechanical 17
 - 6.2 Trouble shooting 18
 - 6.3 Repairs 18
 - 6.4 Safety procedures 19
 - 6.5 Hints to the type plate..... 20
 - 6.6 Hints to the renting/leasing of PROBST devices 20

1 EC-Declaration of Conformity

Description: **Adjustable Paver Transport Cart**
 Type: **VTK-V**
 Order number: **5110.0015**
 Manufacturer: Probst GmbH
 Gottlieb-Daimler-Straße 6
 71729 Erdmannhausen, Germany
info@probst-handling.de
www.probst-handling.de



Complies with the following provisions applying to it

EC-machinery directive 2006/42/EC

Based on the following harmonized standards (in excerpts):

DIN EN ISO 12100

Safety of machinery - General principles for design - Risk assessment and risk reduction (ISO 12100:2010)

DIN EN ISO 13857

Safety of machinery - safety distances to prevent hazard zones being reached by upper and lower limbs (ISO 13857:2008)

Authorized person for EC-documentation:

Name: J. Holderied
 Address: Probst GmbH; Gottlieb-Daimler-Straße 6; 71729 Erdmannhausen, Germany

Signature, information to the subscriber:

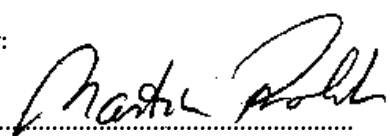
Erdmannhausen, 06.11.2017.....
 (M. Probst, Managing director)

2 General

2.1 Authorized use

- The Adjustable Paver Transport Cart is specially designed for the transport of steel-banded or detached plasters, kerbstones or plates. The capacity and the nominal width of the device must not be exceeded (see “Technical Data”).
- Only rectangular goods have to be lifted with the VTK-V, conical goods could slip off.



- The device is only designed for the use specified in this documentation.
- Every other use is not authorized and is forbidden!
- All relevant safety regulations, corresponding legal regulations, especially regulations of the declaration of conformity, and additional local health and safety regulations have to be observed.



Prior to every operation the user **must** ensure that:

- The equipment is suited to the intended operation, the functioning and the working condition of the equipment is examined, and the load is suitable to be handled.

Any doubts about instructions should be raised with the manufacturer prior to use.



NOT ALLOWED ACTIVITIES:

Unauthorized alterations of the device and the use of any self-made additional equipment could cause danger and are therefore **forbidden!**

Never exceed the **carrying capacity** and the **nominal width/nominal size** of the device.

All unauthorized transportations with the device are not allowed:

- Transportation of people and animals.
- Transportation of other loads and materials than described in this manual.
- Never suspend any goods with ropes, chains or similar at the device.

2.2 Survey and construction

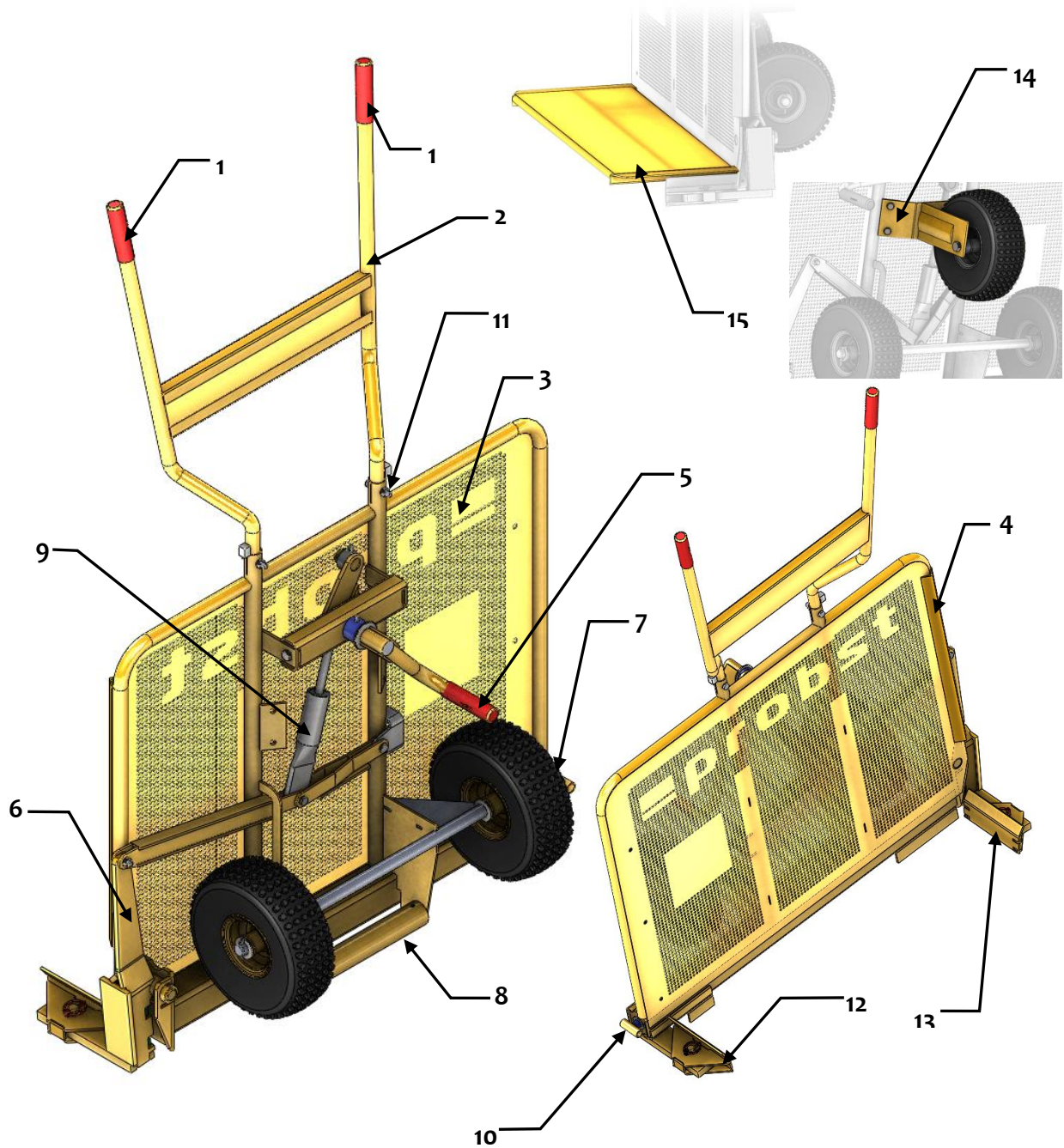

1	PVC-handles	10	Adjusting screw
2	Pipe clamp	11	Standpipe
3	Bottom plate	12	Adjustable jaw
4	Stop for gripping good	13	Moving jaw with griping depth adjustment
5	Clamping lever	14	Supporting wheel (optional) Order No.: 41100041
6	Swing arm for gripper		
7	Wheel		
8	Support roll	15	Insertable storage (optional) (Order No.: 41100010)
9	Overload protection		

2.3 Technical data

Type:	Gripping width mm (in)	Block Height mm (in)	Gripper Length mm (in)	Carrying Capacity kg (lbs)	Dead Weight kg (lbs)	Max. Tyre Pressure bar (psi)
VTK-V	550 – 1.050 (21½ – 41½")	900 (35½")	200 (8")	400 (880)	68 (150)	2,0 (29)

3 Safety

3.1 Safety symbols

**Danger to life!**

Identifies imminent hazard. If you do not avoid the hazard, death or severe injury will result.

**Hazardous situation!**

Identifies a potentially hazardous situation. If you do not avoid the situation, injury or damage to property can result.

**Prohibition!**

Identifies imminent a prohibition. If you do not avoid the prohibition, death and severe injury, or damage to property will result.



Important informations or useful tips for use.

3.2 Safety Marking

Warning sign

Symbol	Meaning	Order No.:	Size [mm]:
	Danger of squeezing the hands.	2904.0221	30 mm
		2904.0220	50 mm
		2904.0107	80 mm

REGULATORY SIGN

Symbol	Meaning	Order No.:	Size [mm]:
	Each operator must have read and understood the operating instructions (and all safety instructions).	2904.0665 2904.0666	30mm 50 mm

INSTRUCTIONS FOR THE OPERATOR

Symbol	Meaning	Order No.:	Size [mm]:
	Hint „Warning, spring tension“ and usage hints	2904.0072	160 x 165

MANUFACTURER LOGOTYPE

Symbol	Meaning	Order No.:	Size [mm]:
	Probst VTK-V logotype	2904.0075	400 x 90

3.3 Definition skilled worker / specialist

Only skilled workers or specialists are allowed to carry out the installation-, maintenance-, and repair work on this device!

Skilled workers or specialists must have for the following points (if it applies for this device), the necessary professional knowledge.

- for mechanic
- for hydraulics
- for pneumatics
- for electricians

3.4 Personal safety requirements



- Each operator must have read and understood the operating instructions (and all safety instructions).
- Only qualified, authorized personal is allowed to operate the device and all devices which are connected (lifting device/carrier).



- The manual guiding is only allowed for devices with handles.

3.5 Protective equipment

The protective equipment must consist, according to the safety regulations of the following parts:

- Protective clothing
- Safety gloves
- Safety shoes

3.6 Accident prevention



- The workplace has to be covered for unauthorized persons, especially children.
- Take care in case of thunderstorm!



- The workplace has to be sufficiently illuminated.
- Take care with handling wet, dirty and not solidified components.



- The working with the device in case of atmospheric editions under 3 °C (37,5 °F) is forbidden! Because the goods could be fall down caused by dampness or freezing.

3.7 Function Control

3.7.1 General



- Before using the device check the functions and the working condition.
- Maintenance and lubrication are only permitted when device is shut down!



- Do not use the device, until all faults which can cause safety hazards are removed.
- If there are any cracks, splits or damaged parts on any parts of the device, **immediately** stop using it.



- The operating instructions must be available at the workplace every time.
- Do not remove the type plate of the machine.
- Unrecognisable information signs (such as regulatory or prohibition signs) must be replaced.

3.8 Safety procedures

3.8.1 General



- The manual guiding of the device is only allowed at the handles.
- The operator is not allowed to leave the control unit as long as the device loaded with load. The load must always be in the range of vision of the operator.



- While using the device the stay of persons in the working area is forbidden. Except it is indispensable, caused of the way of using the device, e.g. if the device must be leaded by hand.
- The jerky lifting and lowering of the device with and without load, e.g. caused through driving fast with the lifting equipment/carrier over uneven grounds is **forbidden**. Unchecked movements of the device can be the result. The gripping good could **fall down**.



- The device should not be opened if the opening path of the gripping arm is blocked by a resistance.
- Never exceed the carrying capacity/working load limit (WLL) and the nominal width of the device.

4 Installation

4.1 Assembly of the VTK-V

The VTK-V is prefabricated, only the handles have to be assembled as follows:

Put the handles (1) into the standpipe (11) and fix it with the pipe clamp.

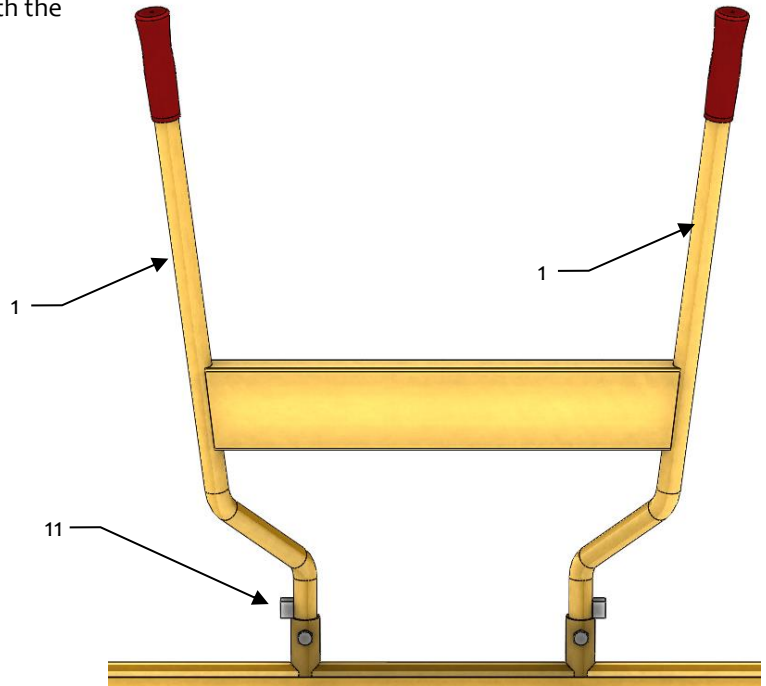

4.2 Adjusting the VTK-V

Turn the clamping lever (5) to the left (as shown)

→ Left clamping jaw (13) is in opened position.

Drive the VTK-V to the gripping good. Take care that the gripping good touches the stop (4).

Turn the adjusting screw (10) clockwise until the right clamping jaw (12) is in light contact with the gripping good.

Turn the screw (10) by two or three complete turns counterclockwise.

Turn the clamping lever (5) clockwise up to the stop.

→ Left gripping jaw (13) touches the good and clamps.

If the operating power for the clamping lever is too big or the gripping good is not fixed, then adjust the VTK-V again and vary the screw (10) appropriate.

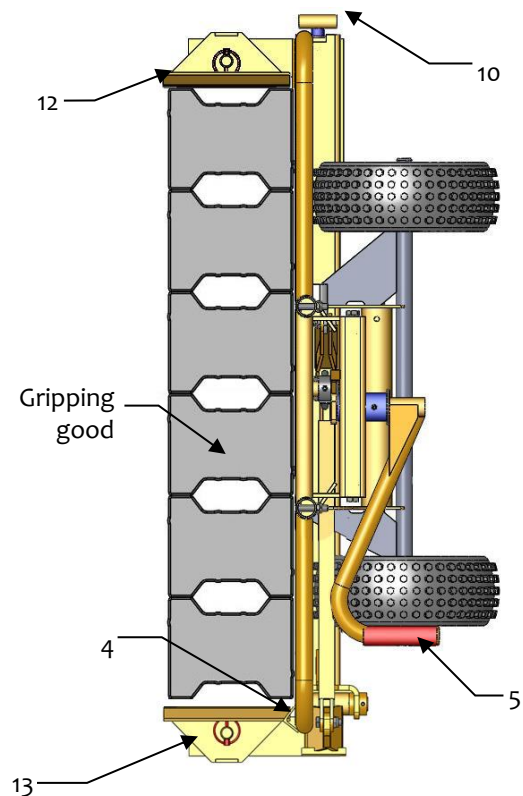

If the load on the lever is too strong, material deformation may appear.

4.3 Installation of supporting wheel (optional)



Before installing accessories, make sure they are in a proper condition.

Mount the supporting wheel (41100041) on the paver transport cart with the four screws. Tighten the screws. The installation position is shown on the opposite.

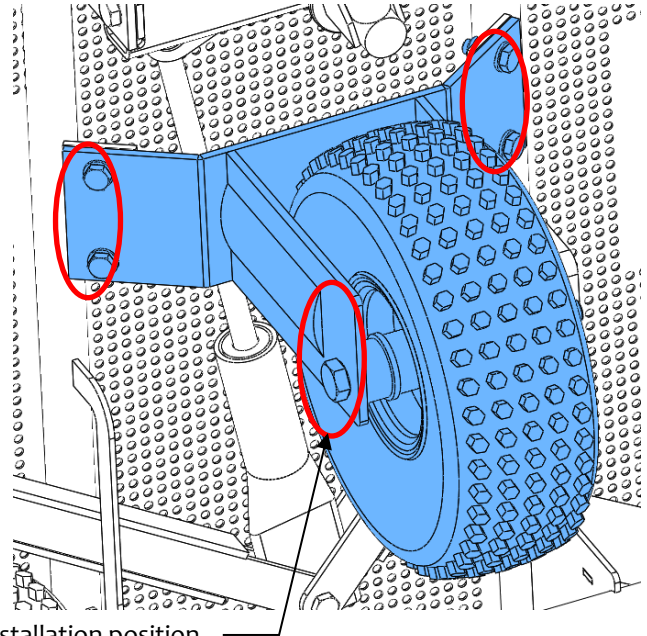

installation position

4.4 Installation of special gripper and wider load support



Before installing accessories, make sure they are in a proper condition.

1. Dismount the gripper (12) by detaching the safety splint and remove the bolt.

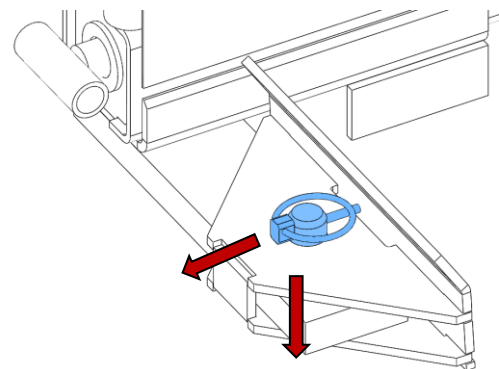

2. Loosen both screws and remove the standard gripper holder.

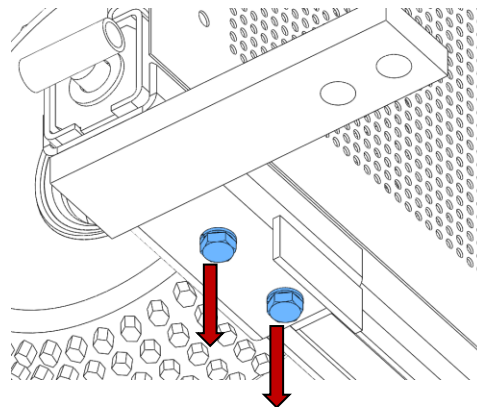

3. Mount the extension for special gripper and fix it with two screws. Tighten up the screws.

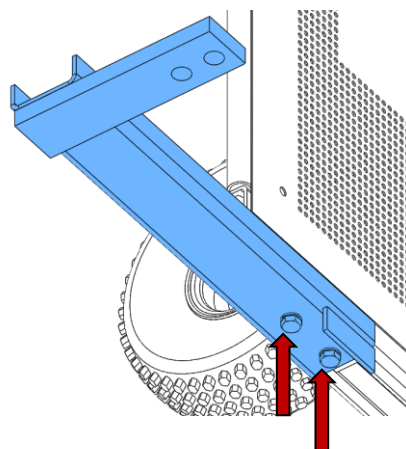

4. Mount the gripper (12) on the extension with bolt and safety splint.

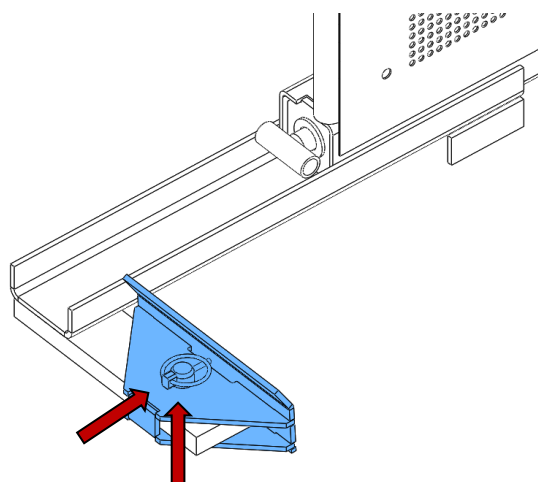

5. Fix the wider load support with tree screws as shown in the picture and tighten up the three nuts.

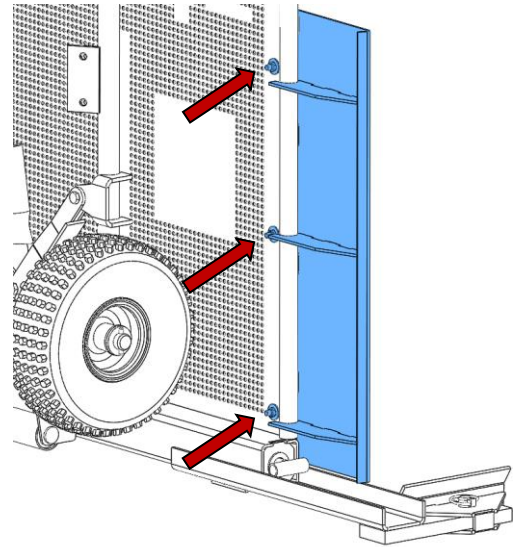

4.5 Installation of insertable storage tray



Before installing accessories, make sure they are in a proper condition.

Attach the flap (A) to the lower edge of the insertable storage tray and then lay the tray on the grippers (B).

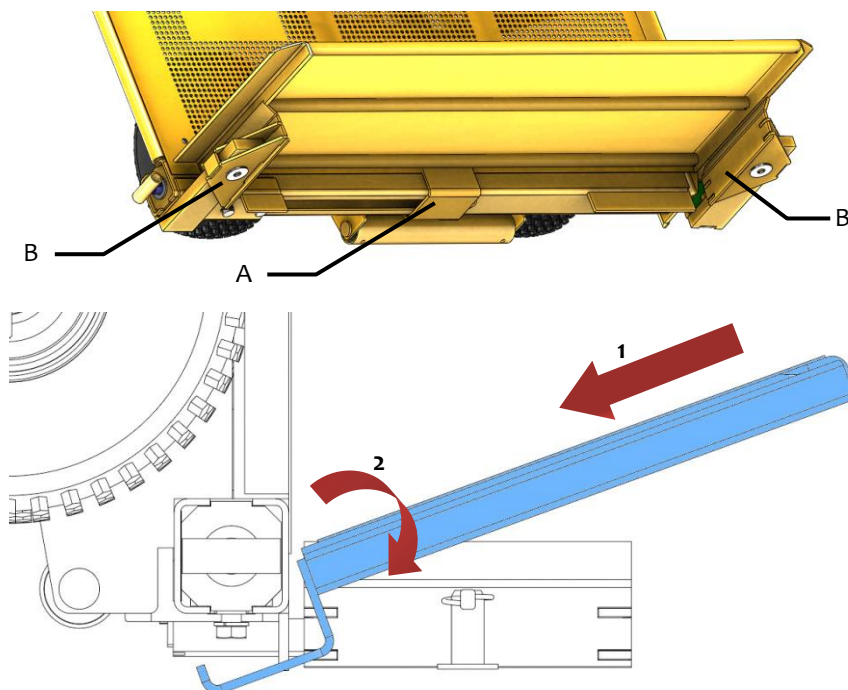

5 Operation

5.1 Loads on firm ground

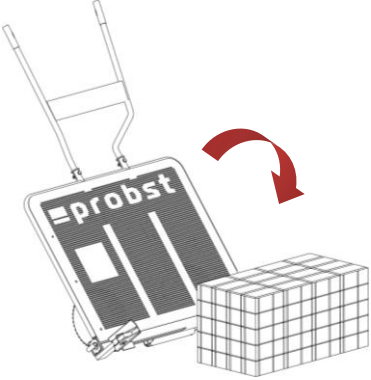
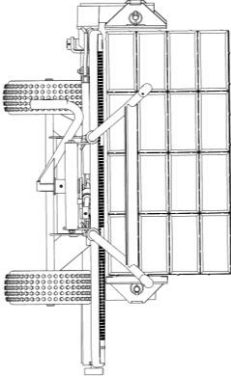
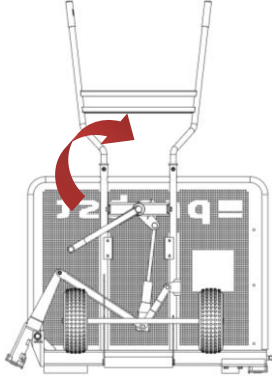
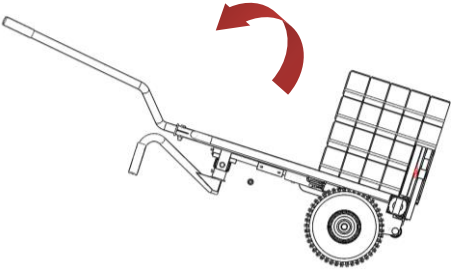
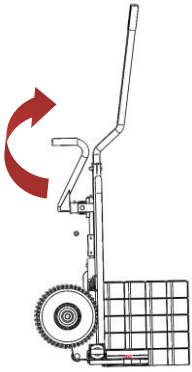
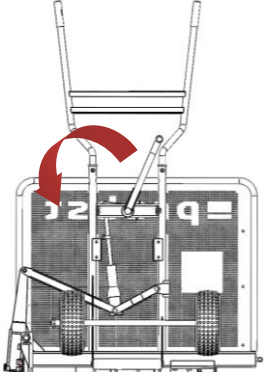
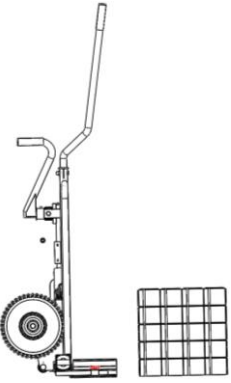
 <p>1. Move the VTK-V carefully to the load.</p>	 <p>2. Bring the stop and the bottom plate in position by placing the VTK-V in the upright position.</p>	 <p>3. Engage the lever up to the stop clockwise, so the load is getting clamped.</p>
 <p>4. Take the VTK-V by the handles, bring it in horizontal position and carefully transport the load to place of destination.</p>	 <p>5. At place of destination, bring the VTK-V carefully in the upright position.</p>	 <p>6. Rotate the lever counterclockwise to release the load.</p>
 <p>7. The VTK-V can now be moved away.</p>		

5.2 Load on the pallet

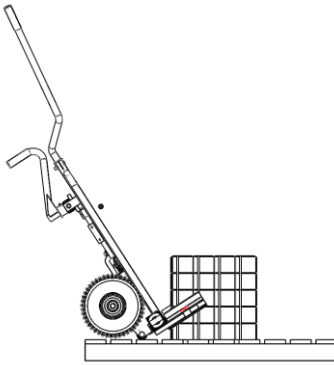

1. Use the support roll to place the VTK-V on the pallet. Move the VTK-V carefully to the load.

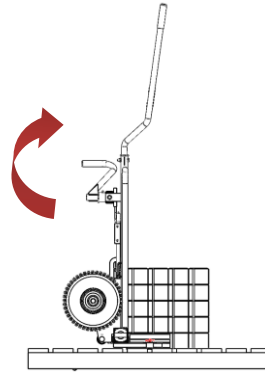

2. Bring the stop and the bottom plate in position by placing the VTK-V in the upright position.

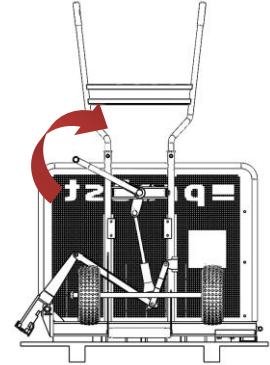

3. Engage the lever up to the stop clockwise, so the load is getting clamped.

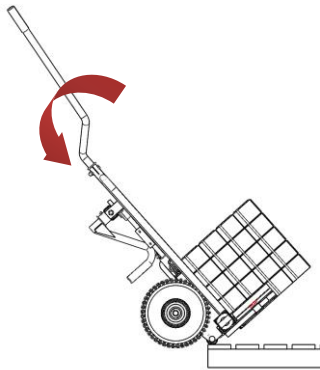

4. Tilt the VTK-V towards yourself and pull it so the support roll is on the edge of the pallet. The wheels have to extend over the edge of the pallet.

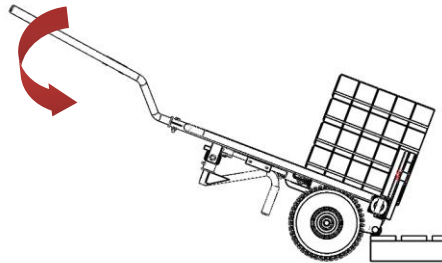

5. Tilt the VTK-V further on until it stands on its wheels.

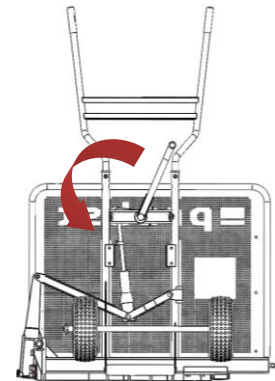

6. At place of destination, bring the VTK-V carefully in the upright position. Rotate the lever counterclockwise to release the load.

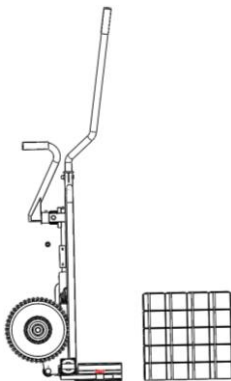

7. The VTK-V can now be moved away.

6 Maintenance and care

6.1 Maintenance



To ensure the correct function, safety and service life of the device the following points must be executed in the maintenance interval.

Used **only original spare parts**, otherwise the warranty expires.



All operations may only be made in closed state of the device!

6.1.1 Mechanical

SERVICE INTERVAL	Maintenance work
First inspection after 25 operating hours	<ul style="list-style-type: none"> Control and tighten all screws and connections. (The implementation is only allowed by an expert).
All 50 operating hours	<ul style="list-style-type: none"> Tighten all screws and connections (take care that the tightening torques according to the property class of the screws are observed). Check all existing safety elements (such as linchpins) for perfect function and replace defective safety elements. → 1) Check all joints, bolts, guidance's and gears for correct function, if necessary adjust or replace it. Check all grippers (if available) for signs of wear. Grease all slidings (if available) when the device is in opened position with a spatula. Grease all grease nipples (if available) with a grease gun.
Minimum 1x per year (at rough conditions shorten the interval)	<ul style="list-style-type: none"> Check of all the suspension parts, bolts and straps. Check for corrosion and safety by an expert.

1)

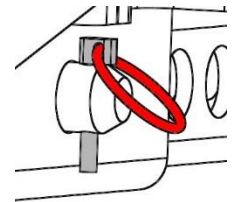
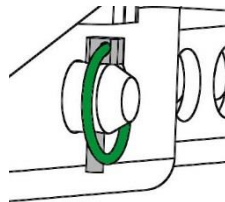

6.2 Trouble shooting

ERROR	CAUSE	REPAIR
The clamping force is insufficient, the load is slipping out		
(optional)	The grippers are worn	Replace the grippers
(optional)	The maximum load is exceeded	Reduce the weight of the load
Adjustment of the gripping range (optional)	The actual opening width is not correct	Adjust the gripping range according to the load you want to transport
Property of material	The surface of the material is dirty or the material is not suitable / allowed for this device	Check the surface of the material or ask the manufacturer, if the material is allowed for this device

6.3 Repairs



- Only persons with the appropriate knowledge and ability are allowed to repair the device.
- Before the device is used again, it has to be checked by an expert.

6.4 Safety procedures

- It is the contractor’s responsibility to ensure that the device is checked by an expert in periods of max. 1 year and all recognized errors are removed (→ see BGR 500).
- The corresponding legal regulations and the regulations of the declaration of conformity have to be observed!
- We recommend that after checking the device, the badge “Safety checked” is put on the device. (Order-No.: 2904.0056+inspection sticker with date).
- You can receive these badges from us.



The check by an expert must be proved!

Device	Year	Date	Expert	Company

6.5 Hints to the type plate



Type, serial-number and production year are very important for the identification of your device. If you need information to spare-parts, warranty or other specific details please refer to this information.

The maximum carrying capacity/working load limit (WLL) is the maximum load which can be handled with the device. Do not exceed this carrying capacity/working load limit (WLL).

If you use the device in combination with other lifting equipment (Crane, chain hoist, forklift truck, excavator) consider the deadweight of the device.



Example:

6.6 Hints to the renting/leasing of PROBST devices



With every renting/leasing of PROBST devices the original operating instructions must be included unconditionally (in deviation of the users country's language, the respective translations of the original operating instructions must be delivered additionally)!

Proof of maintenance



Warranty claim for this machine only apply for performance of the mandatory maintenance works (by an authorised specialist workshop)! After each completed performance of a maintenance interval the included form must be fill out, stamped, signed and send back to us immediately ¹⁾.

1) via e-mail to service@probst-handling.de / via fax or post

Operator: _____

Device type: _____

Device-No.: _____

Article -No.: _____

Year of make: _____

First inspection after 25 operating hours

Date:	Maintenance work:	Inspection by company:
		Company stamp Name Signature

All 50 operating hours

Date:	Maintenance work:	Inspection by company:
		Company stamp Name Signature
		Company stamp Name Signature
		Company stamp Name Signature

Minimum 1x per year

Date:	Maintenance work:	Inspection by company:
		Company stamp Name Signature
		Company stamp Name Signature

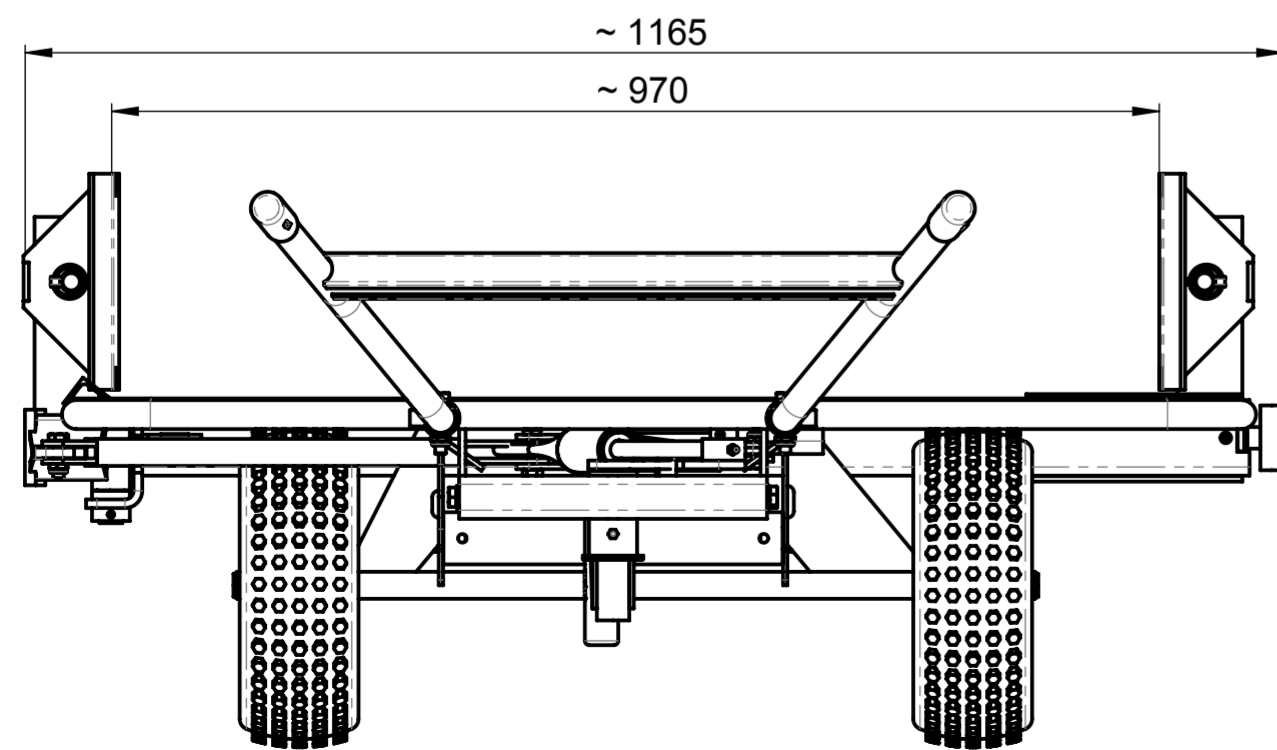
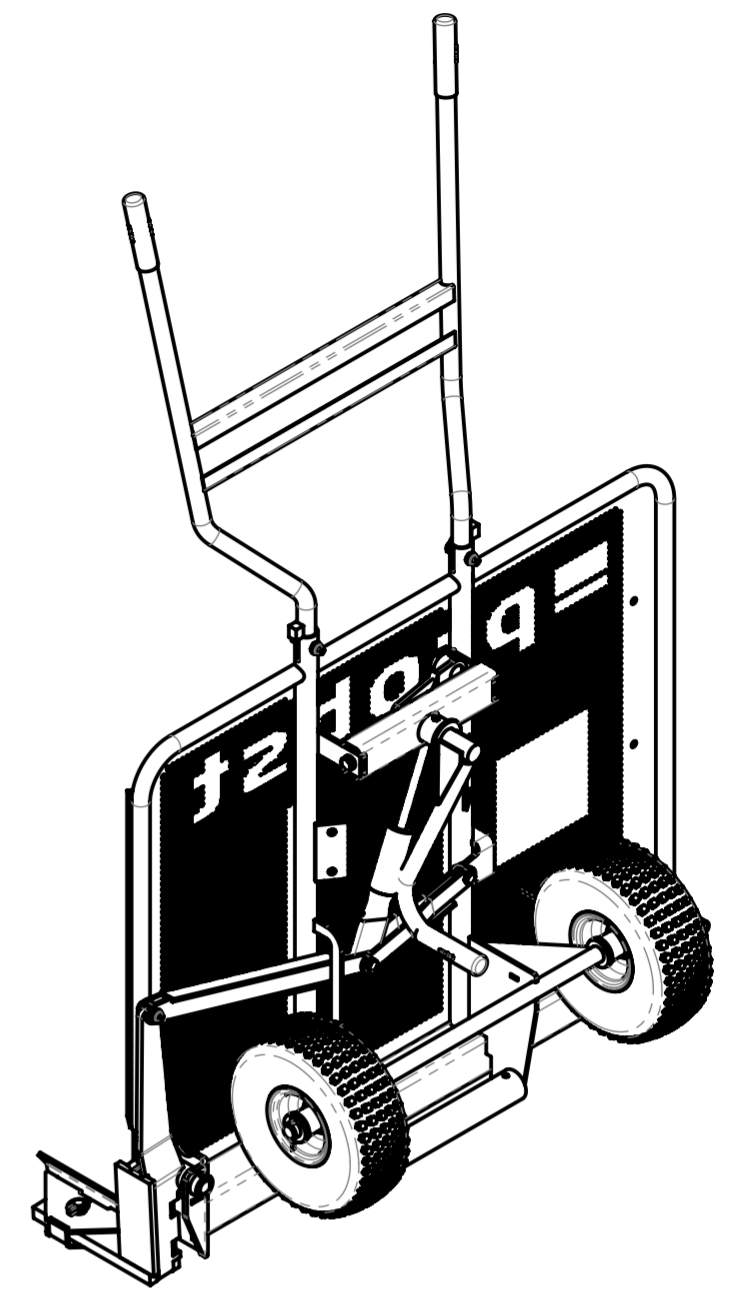
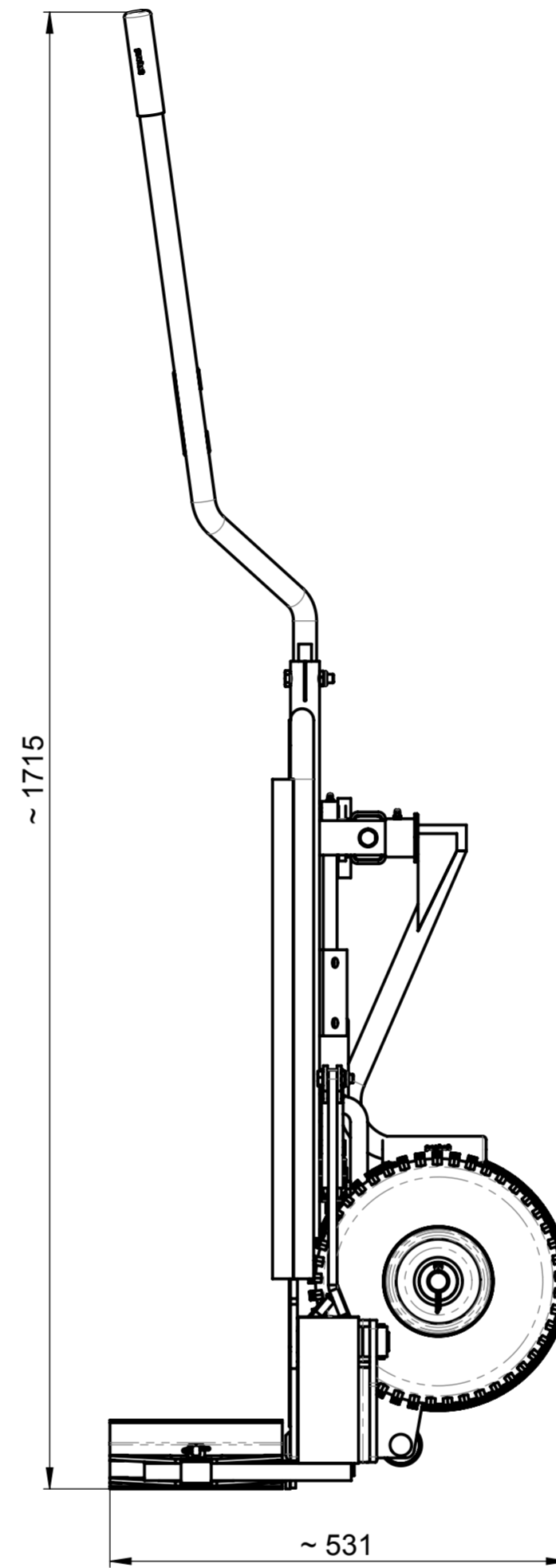
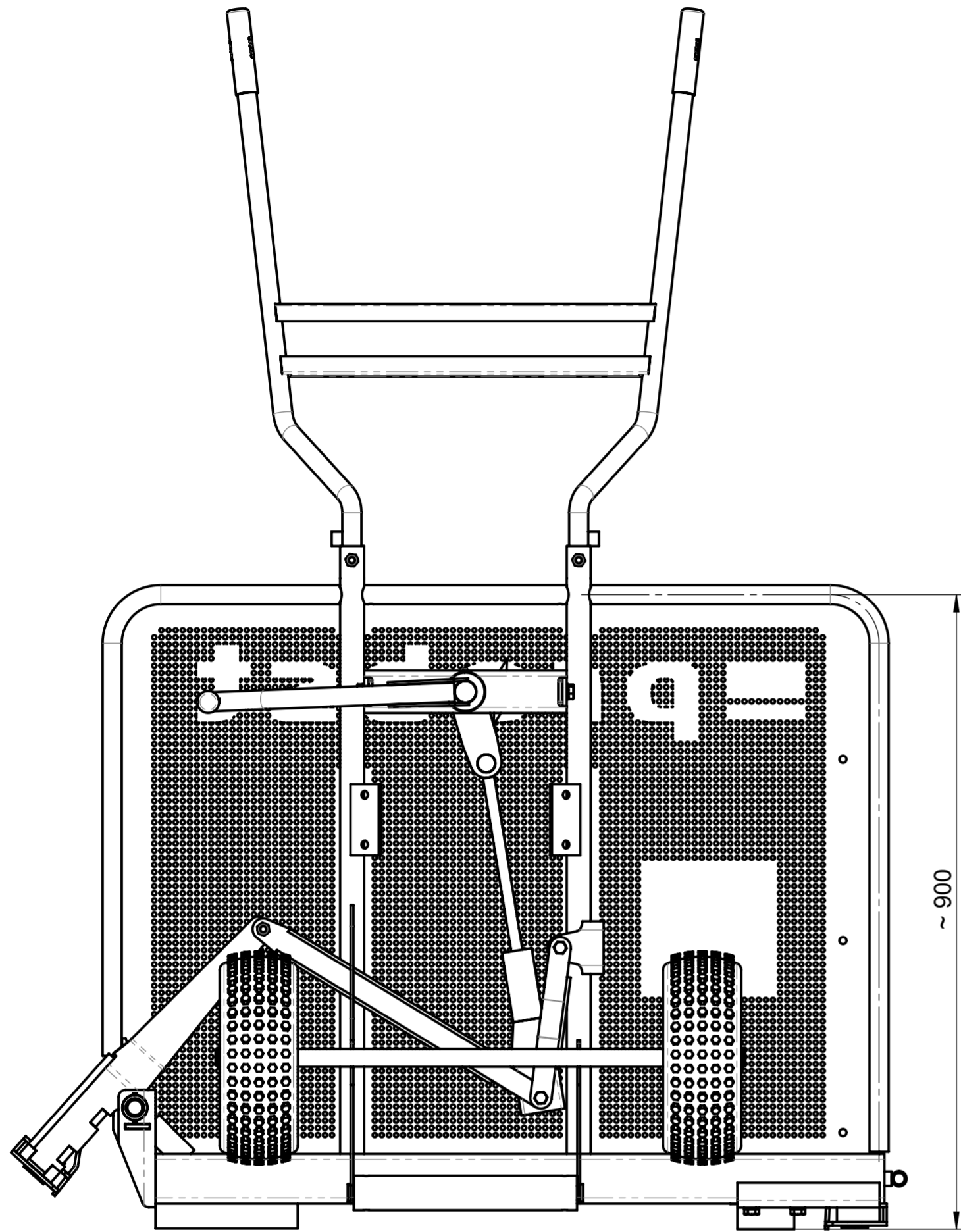

Tragfähigkeit / Working Load Limit WLL:
400 kg / 880 lbs

Eigengewicht / Dead Weight:
68 kg / 150 lbs

Product Name:
Adjustable Paver Transport Cart VTK-V



© all rights reserved conform to ISO 16016

Datum	Name	Benennung
Erst. 27.4.2016	M.Wunder	VTK-V
Gepr. 2.2.2017	M.Wunder	
Artikelnummer/Zeichnungsnummer		Blatt
D51100015		1
Zust. Urspr.		von 1
Ers. f.		Ers. d.



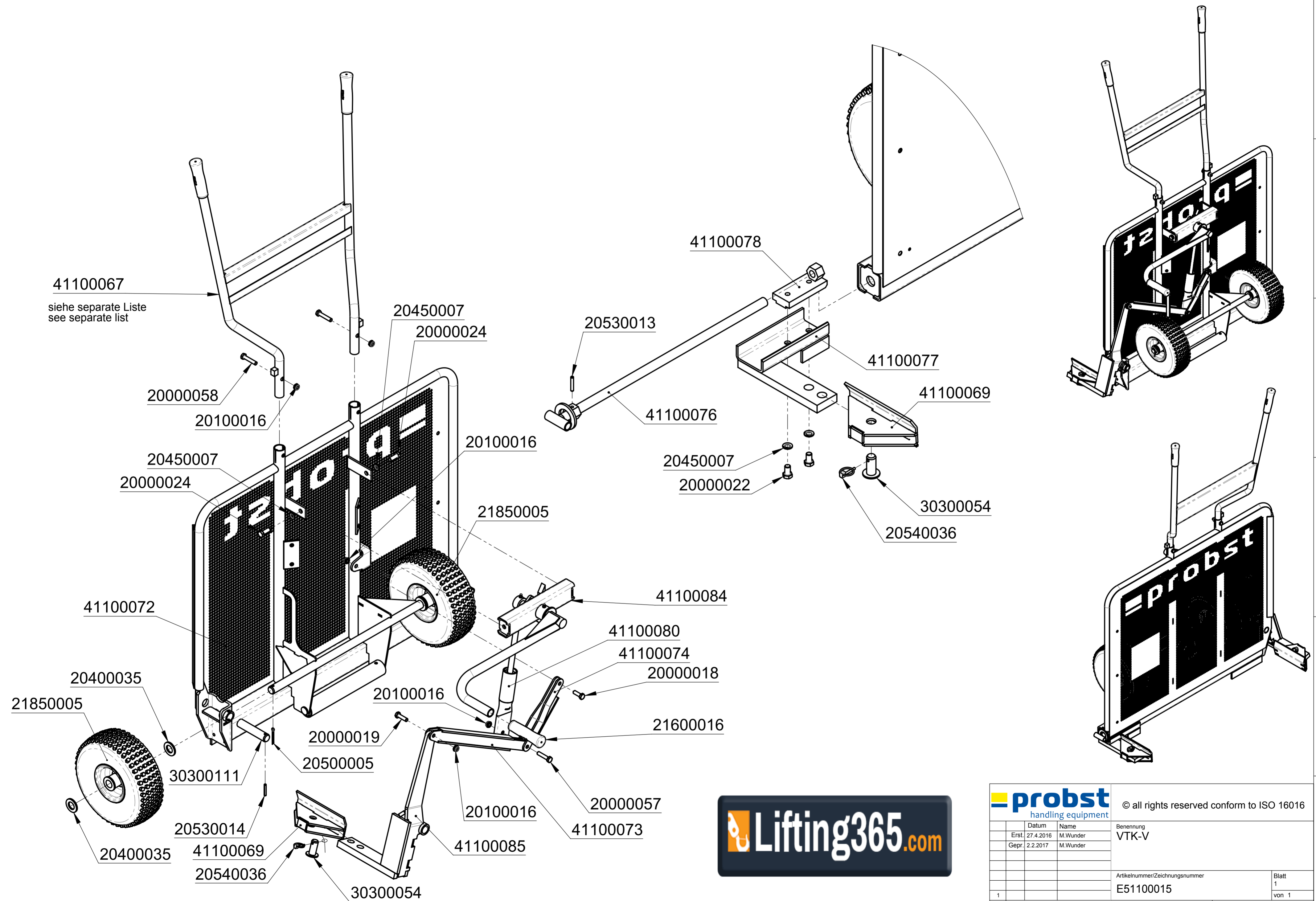

probst handling equipment		© all rights reserved conform to ISO 16016	
	Datum	Name	Benennung
	Erst. 27.4.2016	M.Wunder	VTK-V
	Gepr. 2.2.2017	M.Wunder	
			Artikelnummer/Zeichnungsnummer
			E51100015
1			Blatt 1 von 1
Zust.	Urspr.	Ers. f.	Ers. d.

8

7

6

5

4

3

2

1

F

E

D

C

B

A

21600016

41100106

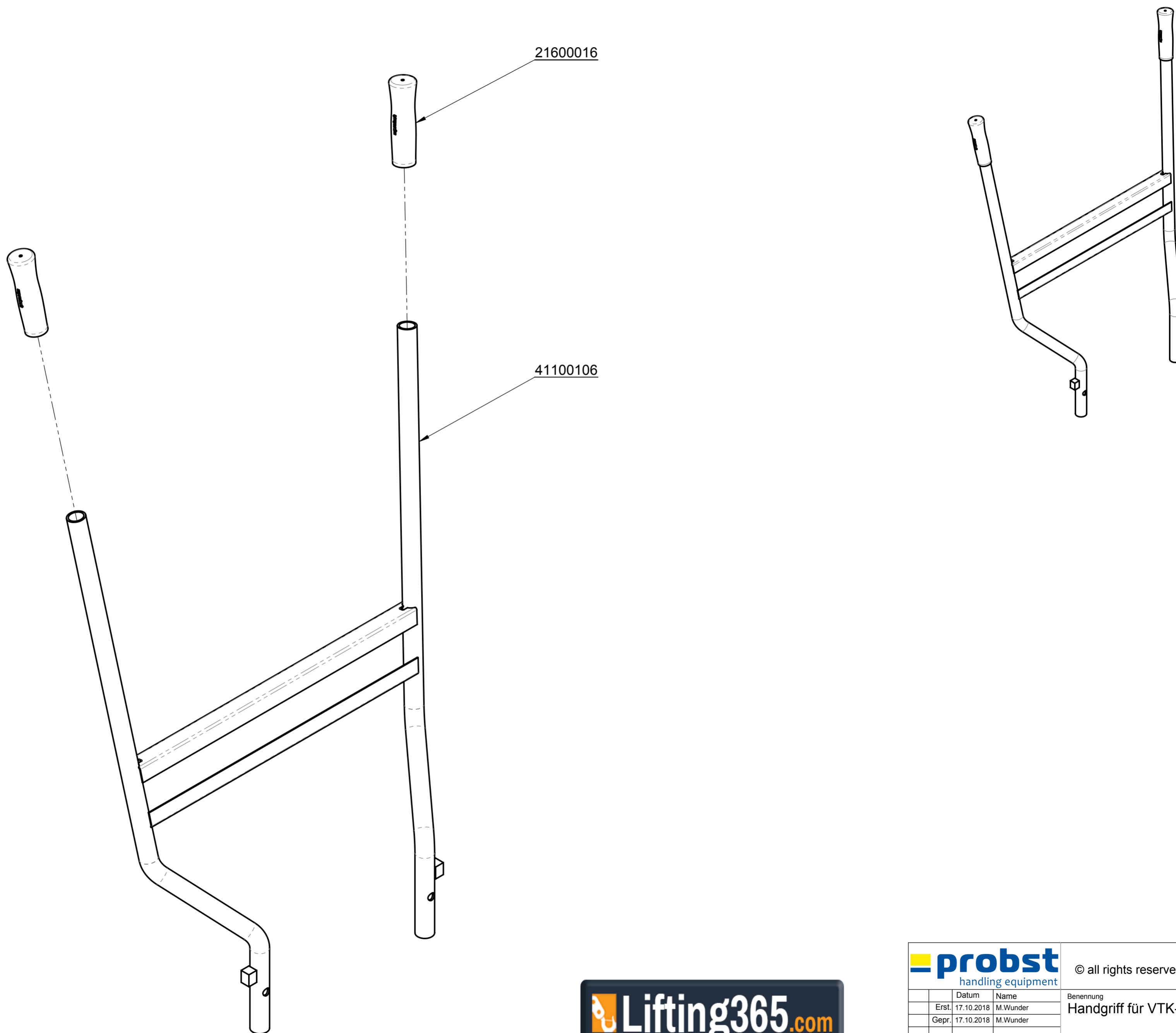

probst
handling equipment

© all rights reserved conform to ISO 16016

	Datum	Name	Benennung
Erst.	17.10.2018	M.Wunder	Handgriff für VTK-V
Gepr.	17.10.2018	M.Wunder	
Artikelnummer/Zeichnungsnummer			Blatt
E41100067			1
Zust. Urspr. J052-30013			von 1
Ers. f.		Ers. d.	

8

7

6

5

4

3

2

1



29040075

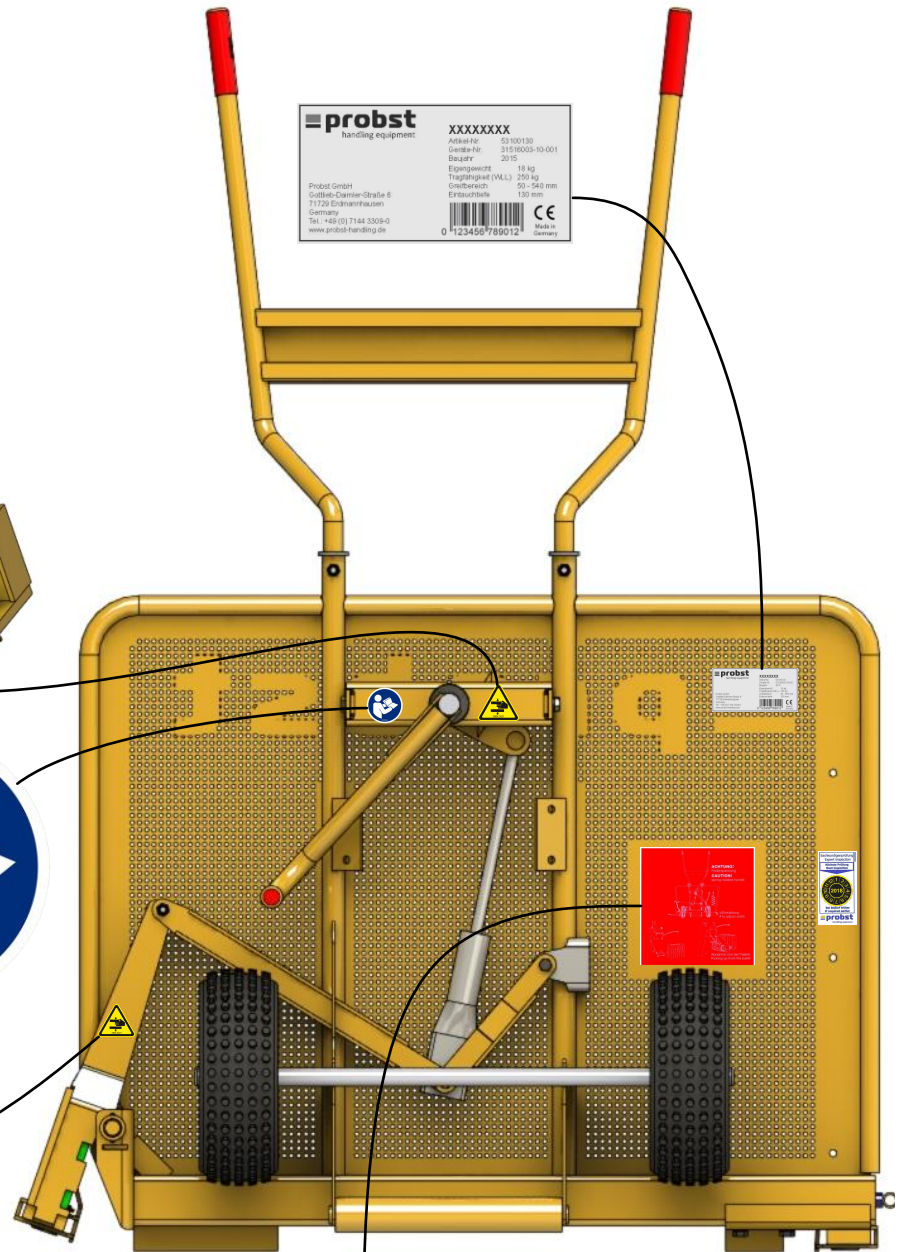

29040665



29040221

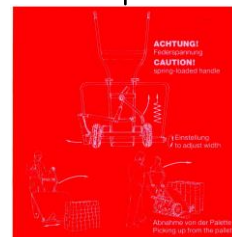

29040072



29040056