

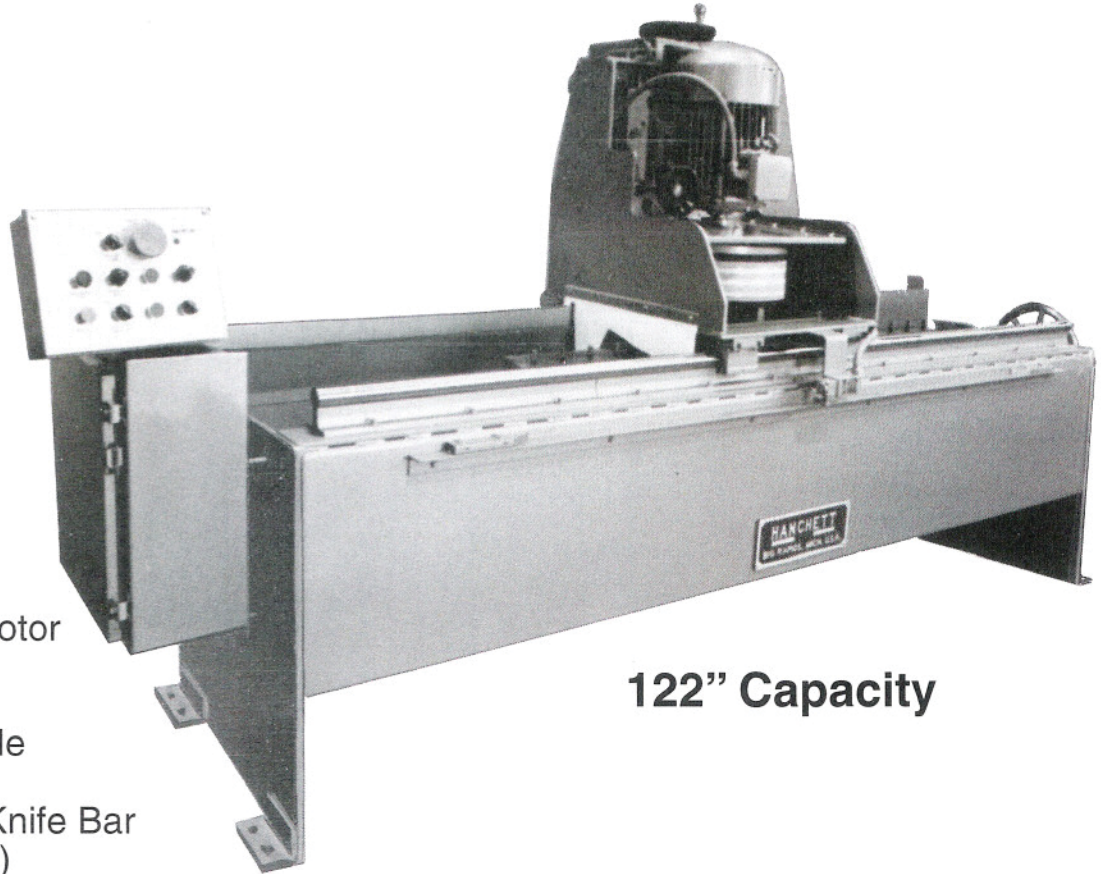

**HANCHETT**

# CHALLENGER

**Vertical Spindle - Traveling Head - Knife Grinder**



## STANDARD FEATURES

- 7½ HP Ball Bearing Head Motor
  - Standard Size Grinding Wheel
  - Built-In Adjustable Wheel Dresser
  - 360° Swiveling Knife Bar (8" x 4" x Length)
  - Precision Angle Indicator
  - Simple, Illuminated Electric Controls
  - Automatic/Manual Variable Rate Downfeed, with Rapid Traverse
  - Limits of Head Traverse Easily Adjustable
  - Infinitely Adjustable Speed of Head Traverse from 5 to 50 FPM
  - Replaceable Ways and Replaceable Head Traverse Bearings
  - Full-flood Coolant System with hollow spindle flow
  - 230 / 460 Volts, 60 Hz, 3 Phase Electrical Input
  - Electronic Downfeed Timer with Finished Cycle Light
  - Worm and Gear Knife Bar Turning Mechanism
- 122" Capacity**
- 60", 84", 122", or 150" Lengths
  - Low Prices
  - Maintenance Free
  - Ready Availability of Parts
  - American Made
  - Minimum Initial Investment



**Smith Sawmill Service**

181 County Road 4763  
Timpson, TX 75975 USA

Phone: 1-800-598-6344

Fax: 936-354-3975

sawmill.shop

info@smithsawmillservice.com





## SIMPLE WHEEL CHANGEOVER

**WHEEL DRESSER IS STANDARD**

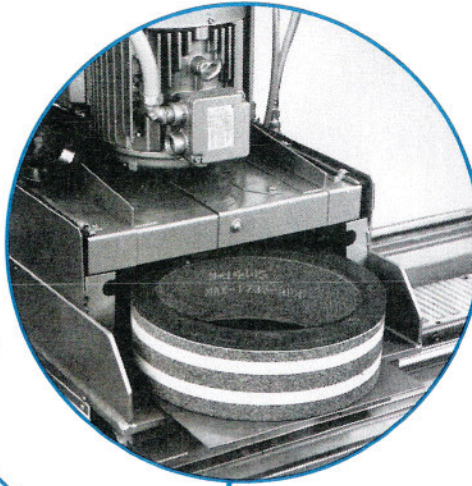
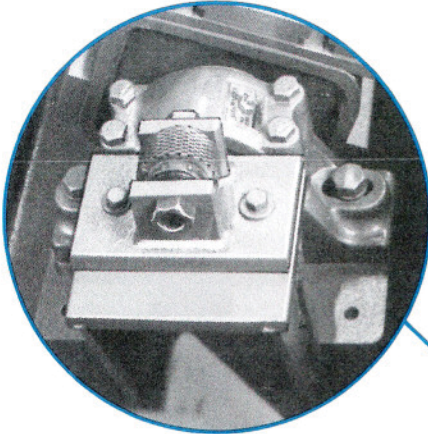

**WORK HEIGHT** – With knife bar at 0° setting, 4" high work can be accommodated.

**SPINDLE ALIGNMENT** – Mounted on a precision slide with replaceable bearings the grinding head can also be adjusted for hollow or flat grinding applications.

**COOLANT SYSTEM** – Free standing Flood Coolant and approximately 6 gpm submersible pump, with piping and discharge nozzles for ample flooding and washing of work.

**LUBRICATION** – All critical points requiring lubrication are with convenient grease fittings.

**DUAL "T"-RAILS**

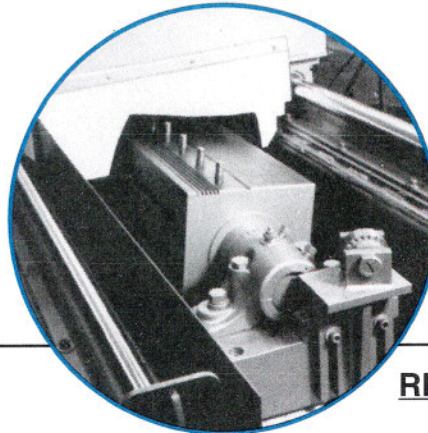

**OPTIONS AVAILABLE:**

- Electronic Infeed System with Digital Readout.
- Segmental grinding wheel.
- Magnetic Knife Bars.
- Acme Knife Bars.

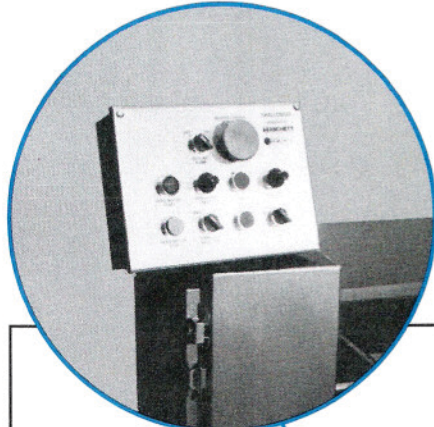

**FUNCTIONAL MACHINE CONTROLS**

**REFERENCE DATA**

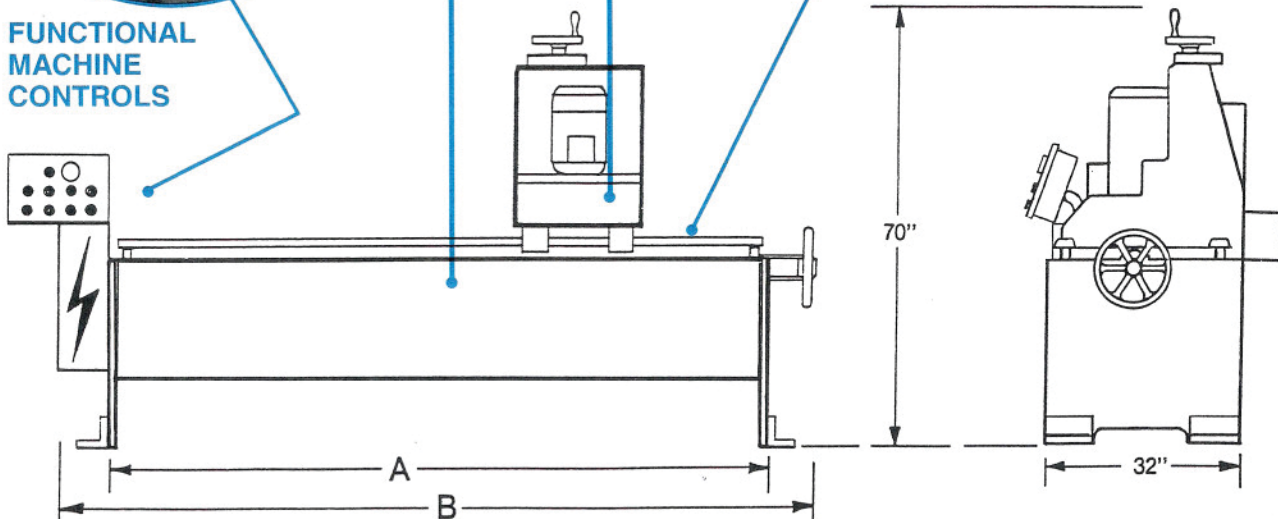

MACHINE MODEL NO.	KNIFE BAR WORKING LENGTH		BASE LENGTH A		OVERALL LENGTH B		OVERALL DIMENSIONS SKIDDED FOR SHIPMENT L x W x H		SHIPPING WEIGHT (APPROX.)	
	Inches	mm	Inches	mm	Inches	mm	Inches	mm	Lbs.	Kg.
CH-60	60	1524	130	2616	112	2845	148x68x78	3759x1727x1981	3950	1778
CH-84	84	2134	127	3226	136	3454	172x68x78	4369x1727x1981	4350	1958
CH-122	122	3099	163	4140	181	4598	218x68x78	5538x1727x1981	5500	2475



**Smith Sawmill Service**

181 County Road 4763  
Timpson, TX 75975 USA

Phone: 1-800-598-6344

Fax: 936-354-3975

sawmill.shop

info@smithsawmillservice.com

