

the new **HANCHETT**

CHALLENGER

Vertical Spindle - Traveling Head - Knife Grinder

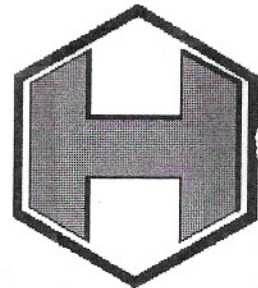
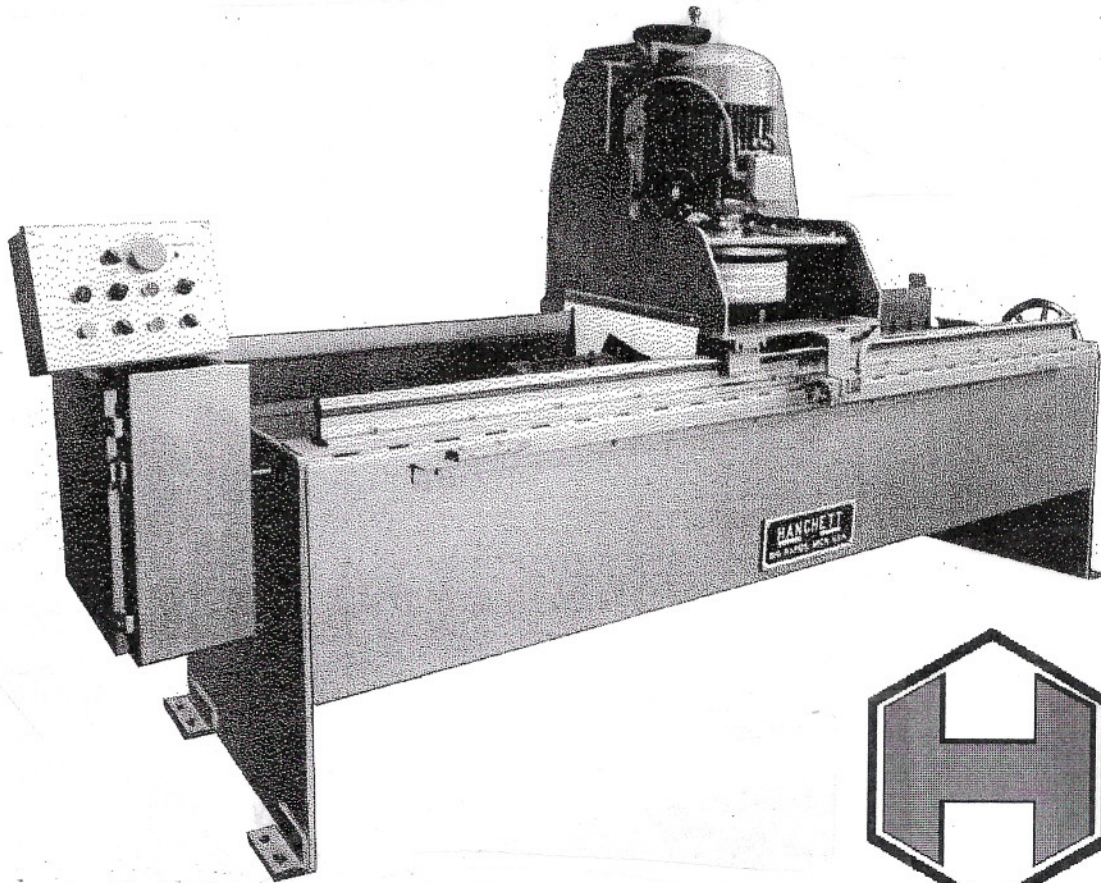

84'' ILLUSTRATED PARTS LIST

HANCHETT MFG.
906 N. STATE
BIG RAPIDS, MI 49307

PH: (800) 454-7463
PH: (231) 796-7678
FAX: (231) 796-4851

TABLE OF CONTENTS

| | |
|-------------------------------|---------------|
| TABLE OF CONTENTS | PAGES 1 & 2 |
| CARRIAGE ASSEMBLY | PAGES 3 & 4 |
| DOWNFEED ASSEMBLY | PAGES 5 & 6 |
| SPLASH GUARD COMPONENTS | PAGES 7 & 8 |
| DRIVE SYSTEM | PAGES 9 & 10 |
| BASE ASSEMBLY | PAGES 11 & 12 |
| COOLANT SYSTEM | PAGES 13 & 14 |
| DRESSER ASSEMBLY | PAGES 15 & 16 |
| KNIFE BAR ASSEMBLY | PAGES 17 & 18 |
| ELECTRICAL ASSEMBLY | PAGES 19 & 20 |
| SPARE PARTS COMPONENTS | PAGES 21 & 22 |

NOTES:

IMPORTANT:

WHEN ORDERING REPAIR PARTS FOR
YOUR MACHINE, YOU NEED TO KNOW
THE SERIAL NUMBER OF YOUR
MACHINE. THIS INFORMATION IS
FOUND ON THE NAMEPLATE LOCATED
ON THE BASE OF THE MACHINE. IT
IS OF GREAT ASSISTANCE TO US,
IF YOU CAN INCLUDE A PART NAME
AND PART NUMBER WHEN POSSIBLE.

SERIAL NO. _____

- | | | |
|----|----------|-------------------------------|
| 1 | CH-0184 | CARRIAGE |
| 2 | CH-0194 | CARRIAGE BACK PLATE |
| 3 | CH-0191 | CARRAIGE RAIL |
| 4 | CH-0197 | SLIDE |
| 5 | CH-0030 | SWIVEL PLATE |
| 6 | CH-0027 | MOTOR SPACER (2) REQ'D |
| 7 | BAA0124R | 5 HP 1200RPM MOTOR |
| 8 | CH-0048 | WHEEL COLLAR |
| 9 | LH-65 | WHEEL PLATE |
| 10 | CH-0034 | PILLOW BLOCK SPACER (4) REQ'D |
| 11 | CVV0012J | FLOATING BEARING (2) REQ'D |
| 12 | CVV0002S | FIXED BEARING (2) REQ'D |
| 13 | CVV0014T | OPEN SLEEVE BEARING (4) REQ'D |
| 14 | CVV0011B | OPEN PILLOW BLOCK (4) REQ'D |
| 15 | CH-0192 | WHEEL CHANGE PLATE |

8

2

1



10

11

12

15

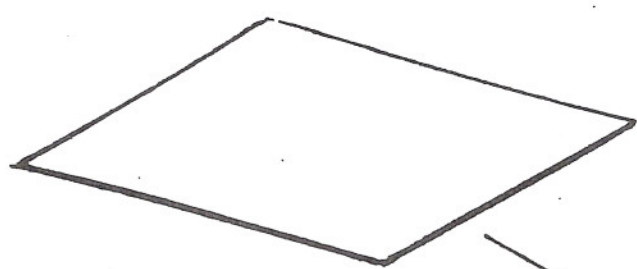

3

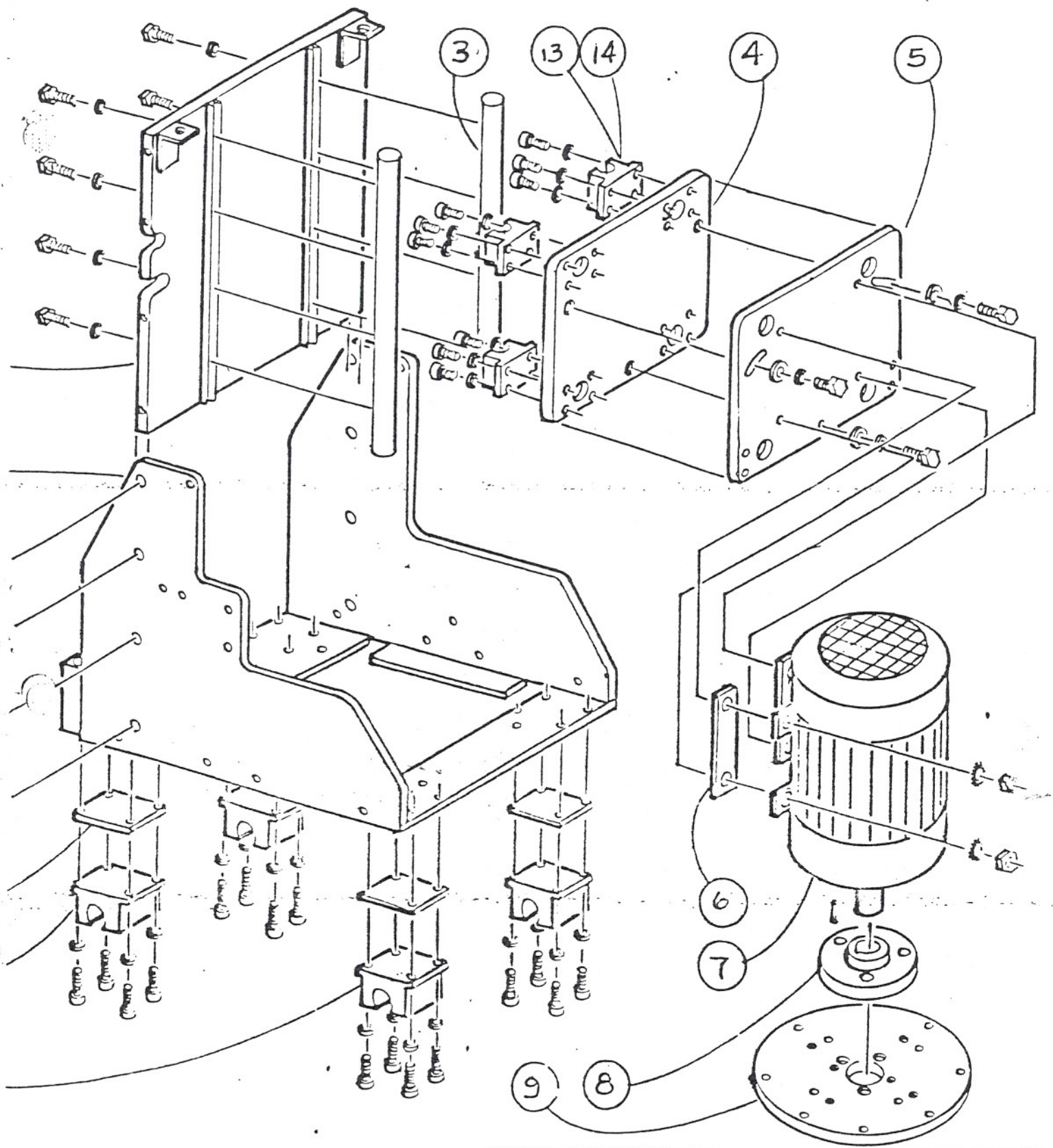

| | | | |
|-------------------|--------|-------|--------------|
| TITLE | | | |
| CARRIAGE ASSEMBLY | | | |
| | | | |
| DR BY | DATE | SCALE | REF LAYOUT |
| CRISENBERG | / / | | CHALL NUMBER |
| CKD | | | |
| SHT | DWG NO | | |

4

| | | |
|----|-----------|-------------------------|
| 16 | BGG0114R | 1/8 HP - 37RPM MOTOR |
| 17 | CH-0024 | DOWNFEED SWIVEL PLATE |
| 18 | CH-0200 | DOWNFEED MOUNTING PLATE |
| 19 | CH-0053 | SPUR GEAR |
| 20 | CH-0053-1 | SPUR GEAR |
| 21 | CH-0026-1 | DOWNFEED SCREW W/ NUT |
| 23 | CH-0052 | FEED SCREW HANDWHEEL |
| 24 | CH-0201 | DOWNFEED NUT BRACKET |
| 25 | CH-0100-1 | UPPER CARRIAGE COVER |
| 26 | GAA0001D | SWIVEL SCREW CLAMP |
| 27 | GAA0002V | TOGGLE CLAMP |
| 28 | CEE0088S | BRONZE BUSHING |
| 29 | PAK0005T | 1" SHAFT COLLAR |
| 30 | CDD0012T | THRUST BEARING |
| 31 | PAP0001T | WIRE SPRING |

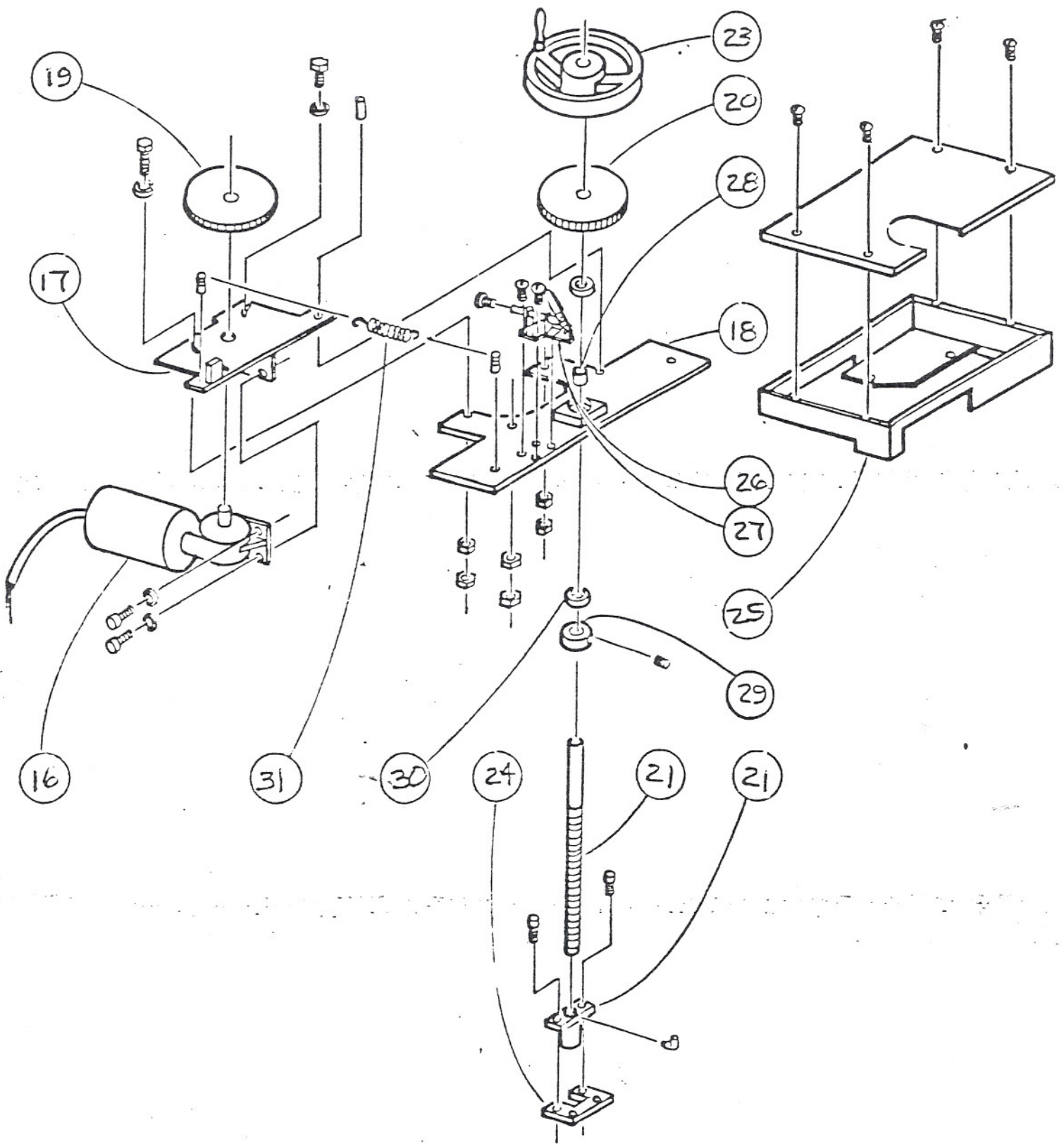

| | | | |
|-------------------|--------|-------|----------|
| TITLE | | | |
| DOWNFEED ASSEMBLY | | | |
| DR BY | DATE | SCALE | REF LAYO |
| CRISENBERG | / / | | C HALLEN |
| CKD | DWG NO | | |
| SHT | | | |

| | | |
|----|-----------|-----------------------|
| 32 | CH-0091 | FEED SCREW GUARD |
| 33 | CH-0093 | REAR SPLASH GUARD |
| 34 | CH-0094 | FRONT SPLASH GUARD |
| 35 | CH-0095 | CARRIAGE SPLASH GUARD |
| 36 | CH-0097-1 | CLAMP STRIP |
| 37 | CH-0098-1 | CLAMP STRIP |
| 38 | CH-0108 | BRUSH STRIP |
| 39 | CH-0225 | FRONT CLAMP STRIP |
| 40 | CH-0226 | WHEEL ACCESS DOOR |
| 41 | CH-0231 | WHEEL COVER GUARD |
| 42 | PAA0021K | 1/4" TUBING STRAP |
| 43 | 100-377 | DRESSER SLOT COVER |

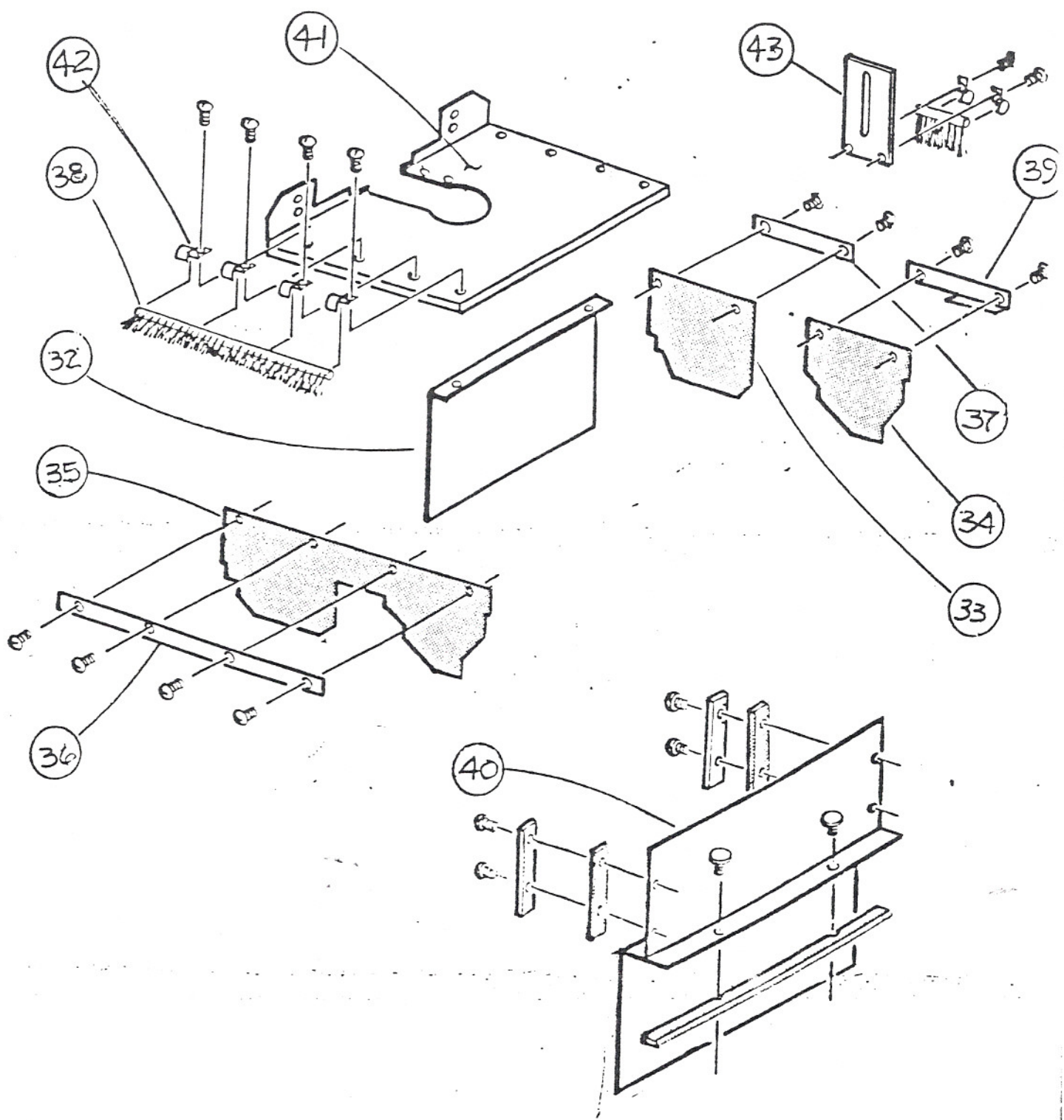

| | | | |
|---------------|--|------------|-------------|
| TITLE | | | |
| SPLASH GUARDS | | | |
| DR BY | | DATE | SCALE |
| CRISENBERRY | | / / | REF. LAYOUT |
| CK'D | | CHALLENGER | |
| SHT | | DWG NO | |

| | | |
|----|-----------|--------------------------------|
| 44 | BBB0018F | 1/2 HP - 1800RPM MOTOR |
| 45 | BHH0017K | GEAR REDUCER 30:1 |
| 46 | CH-0021 | LOCKING SHAFT BRACKET |
| 47 | CH-022-2 | TRANSMISSION LOCKING SHAFT |
| 48 | CH-0054 | TRANSMISSION LOCKING BRKT |
| 49 | CH-0055 | TRANSMISSION LOCKING HANDWHEEL |
| 50 | CH-0085 | TRANSMISSION DRIVE SPRING |
| 51 | CH-0086 | TRANSMISSION LOCKING SPRING |
| 52 | CH-0089 | TRANSMISSION MOTOR GUARD |
| 53 | CH-0195 | LIMIT SWITCH MOUNTING BRKT |
| 54 | CH-0198 | TRANSMISSION MOUNTING PLATE |
| 55 | CH-0199 | TRANSMISSION HINGE PIN |
| 56 | CH-0229 | SPROCKET |
| 57 | CKK0037Y | PILLOW BLOCK BEARING |
| 58 | CRR0005D | 5/8 FEMALE SPHERICAL BEARING |
| 59 | PAK0004L | 3/4" SHAFT COLLAR |
| 60 | PCC0120C | 1/2-13 x 6" SOC CAP SCREW |
| 61 | CH-0007 | MOVABLE CHAIN TENSIONER |
| 62 | CH-0008 | CHAIN ANCHOR |
| 63 | CH-0009 | FIXED CHAIN TENSIONER |
| 64 | CH-0049 | CHAIN RAIL |
| 65 | CH-0063 | ROLLER RAIL |
| 66 | CH-0072-1 | CHAIN |
| 67 | CH-0167 | TRIP DOG RAIL |
| 68 | CH-0173 | CARRIAGE OVERTRAVEL STOP |
| 69 | DHH0007Y | CONNECTING LINK |
| 70 | MG-009 | L.H. TRIP DOG |

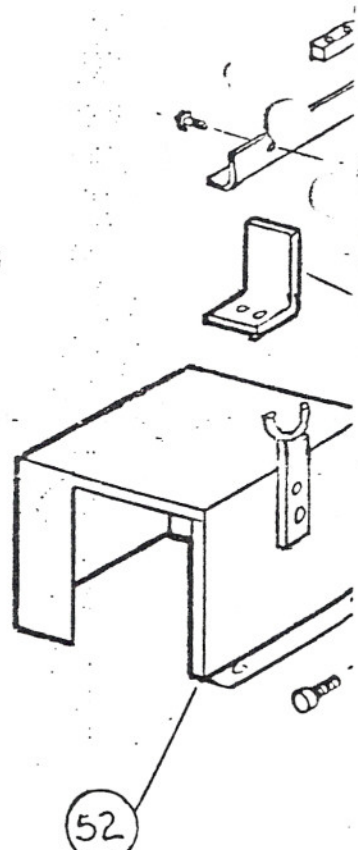

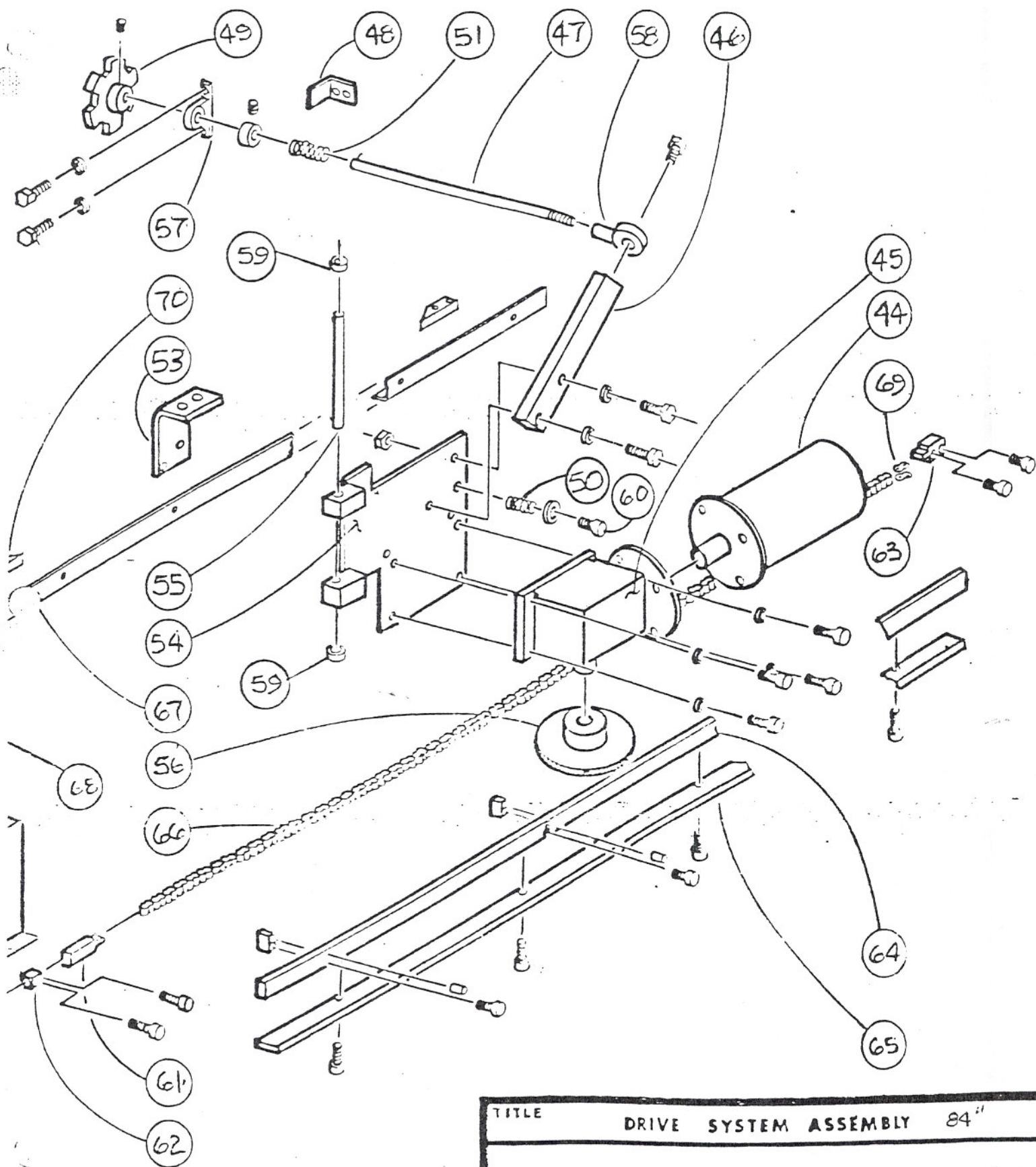

| | | | |
|-----------------------|--------|-------|------------|
| TITLE | | | |
| DRIVE SYSTEM ASSEMBLY | | | 84" |
| DR BY | DATE | SCALE | REF LAYOUT |
| CHK'D | / / | | CHALLENGER |
| SHT | DWG NO | | |

| | | |
|----|-----------|----------------------------|
| 71 | CH-0103 | LEVELING PAD |
| 72 | CH-0170 | SPLASH COVER W/ PROTRACTOR |
| 73 | CH-0172 | PLAIN SPLASH COVER |
| 74 | CH-0179-2 | BASE RAIL ASSEMBLY |
| 75 | CH-0187-A | FINISHED BASE |
| 76 | CH-0193-2 | BASE RAIL SPLASH GUARD |
| 77 | DN-348 | NAMEPLATE |

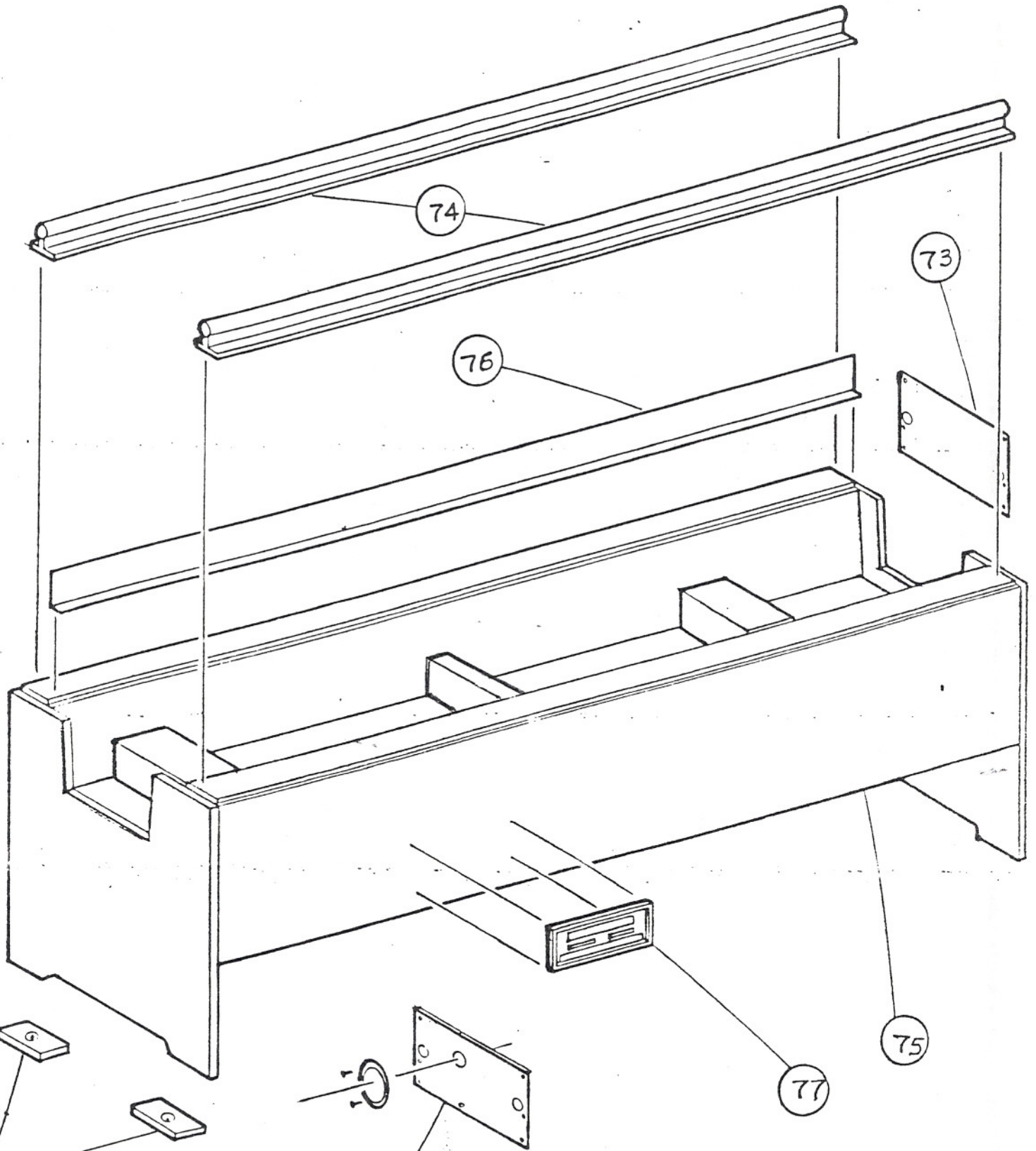

71

72

12

77

75

| | | | |
|-------------------|--|-------------|-------|
| TITLE | | | |
| BASE ASSEMBLY 84" | | | |
| DR. BY | | DATE | SCALE |
| CRISENBERRY | | / / | |
| CK'D | | REF. LAYOUT | |
| | | CHALLENGER | |
| SHT. | | DWG. NO. | |

| | | |
|----|----------------|---------------------|
| 78 | CH-0246 | COOLANT PIPE HOLDER |
| 79 | FBB0070L | 1/2" SHUT-OFF VALVE |
| 80 | JAA0008A | COOLANT PUMP |
| 81 | KLL0011H | VINYL TUBING |
| 82 | KLL0028L | 1/2 " LOC-LINE HOSE |
| 83 | PAE0004Z | WORM GEAR CLAMP |
| 84 | PBB0030F | 1/2 X 3" NIPPLE |
| 85 | PBB0080F | 1/2" STREET ELL |
| 86 | PBB0118D | 1/2" TEE |
| 87 | PBB0159V | 1/2 X 12" NIPPLE |
| 88 | PBB0247F | 1/2 X 8" NIPPLE |
| 89 | RA-177 | COOLANT TANK |
| 90 | 1-502-01-095-2 | COOLANT STRAINER |

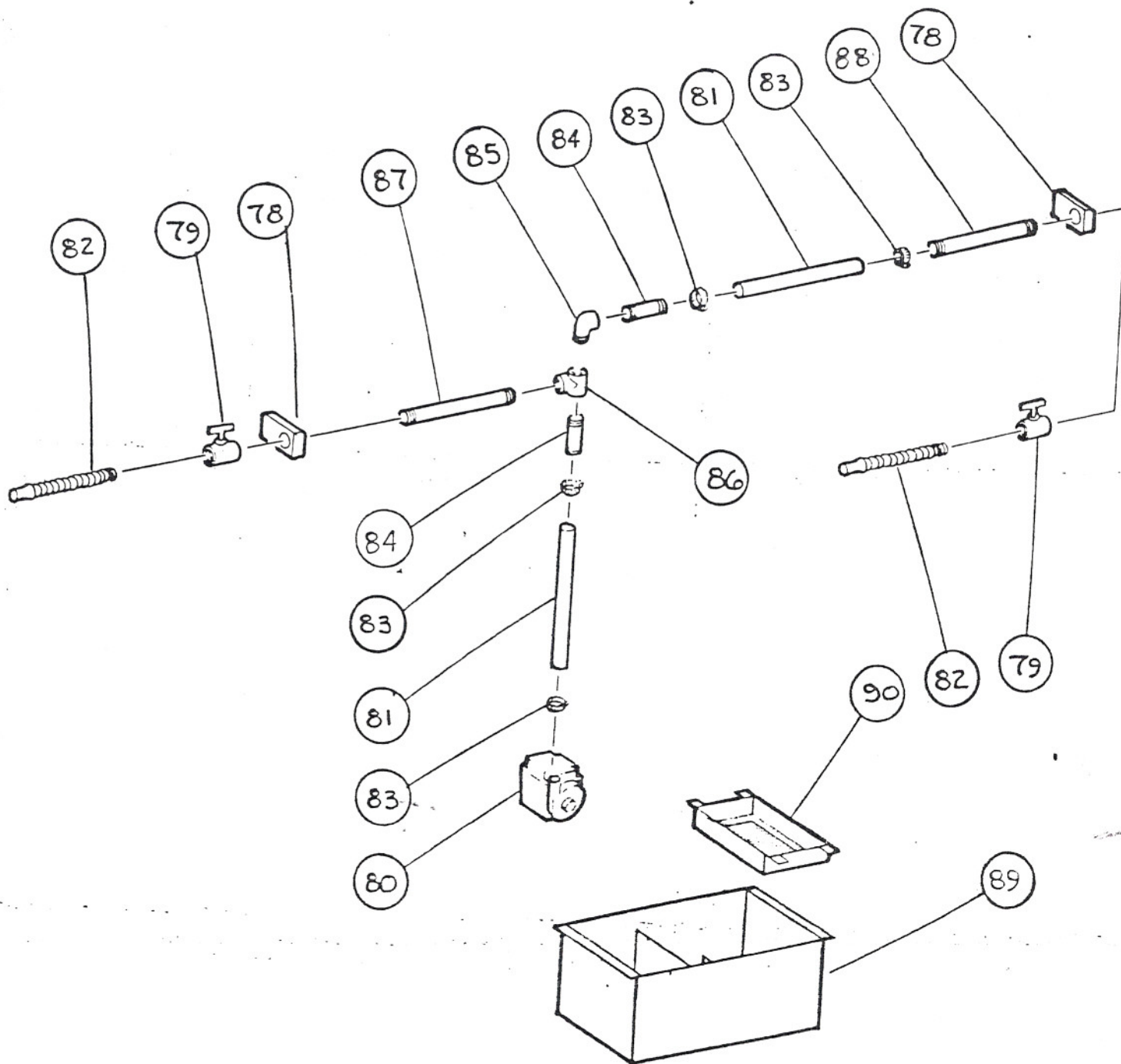

| | | | |
|----------------|----------|-------|-------------|
| TITLE | | | |
| COOLANT SYSTEM | | | |
| DR. BY | DATE | SCALE | REF. LAYOUT |
| CRISENBERY | / / | | CHALLENGER |
| CK'D | DWG. NO. | | |
| SHT. | | | |

14

| | | |
|----|----------|------------------------------|
| 91 | CH-0185 | DRESSER BRACKET |
| 92 | CH-0190 | DRESSER MOUNTING RAIL |
| 93 | PCC0021s | 3/8-16 x 1-1/4 SOC CAP SCREW |
| 94 | PXX0006P | 3/8" FLAT WASHER |
| 95 | SA00231C | "CC" ASSEMBLY |
| 96 | 25-062 | CENTER NUT |
| 97 | 25-064 | CENTER SCREW |

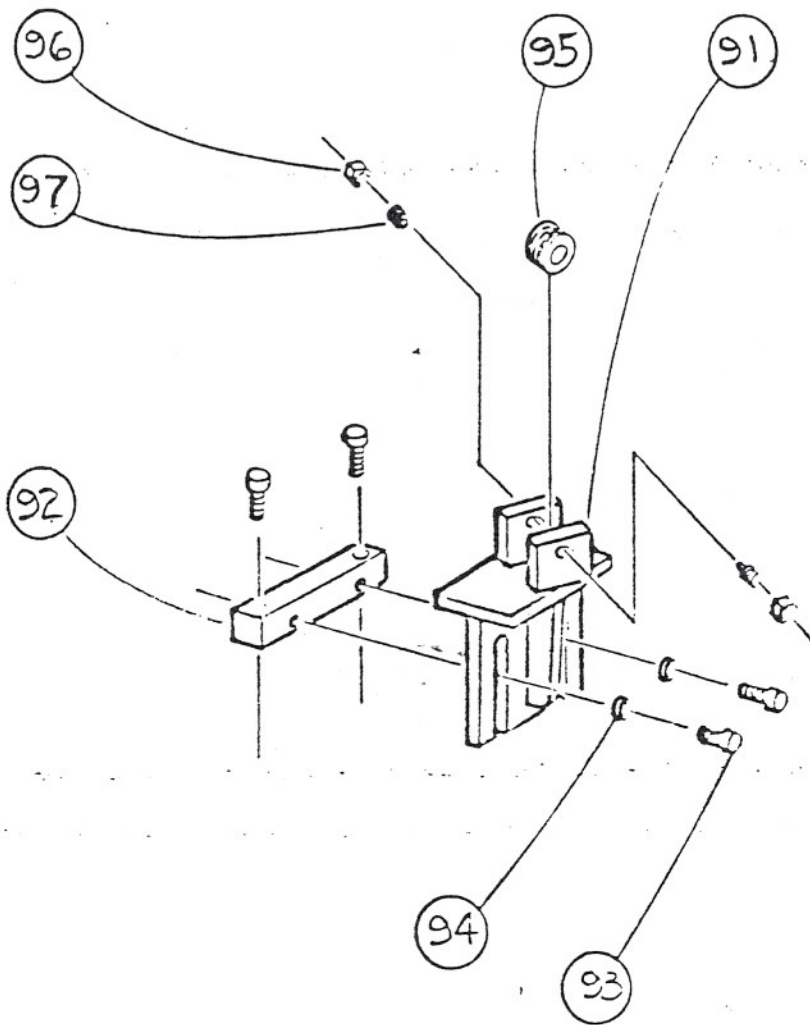

| | | | | | | | |
|-------------|--|--|--|------------------------|--|-------|------------|
| TITLE | | | | WHEEL DRESSER ASSEMBLY | | | |
| DR BY | | | | DATE | | SCALE | REF LAYOUT |
| CRISENBERRY | | | | / / | | | CHALLENGER |
| CK'D | | | | DWG NO | | | |
| SHT. | | | | | | | |

16

| | | |
|-----|----------|--------------------------|
| 98 | CH-0056 | HANDWHEEL |
| 99 | CH-0144 | KNIFE BAR SHAFR |
| 100 | CH-0155 | SLEEVE BEARING |
| 101 | CH-0180 | SLEEVE BEARING |
| 102 | CH-0158 | R.H. KNIFE BAR BRG BLOCK |
| 103 | CH-0159 | L.H. KNIFE BAR BRG BLOCK |
| 104 | CH-0169 | POINTER ASSEMBLY |
| 105 | CH-018Z | CENTER KB BEARING BLOCK |
| 106 | AK-615 | KNIFE CLAMP |
| 107 | CH-0183 | 84" KNIFE BAR |
| 108 | MDD0014P | OFFSET SOCKET WRENCH |
| 109 | PPP0011D | 1/2-13 HEX NUT |
| 110 | PXX0007g | 1/2" FLAT WASHER |
| 111 | VR-251-5 | KNIFE CLAMP STUD |

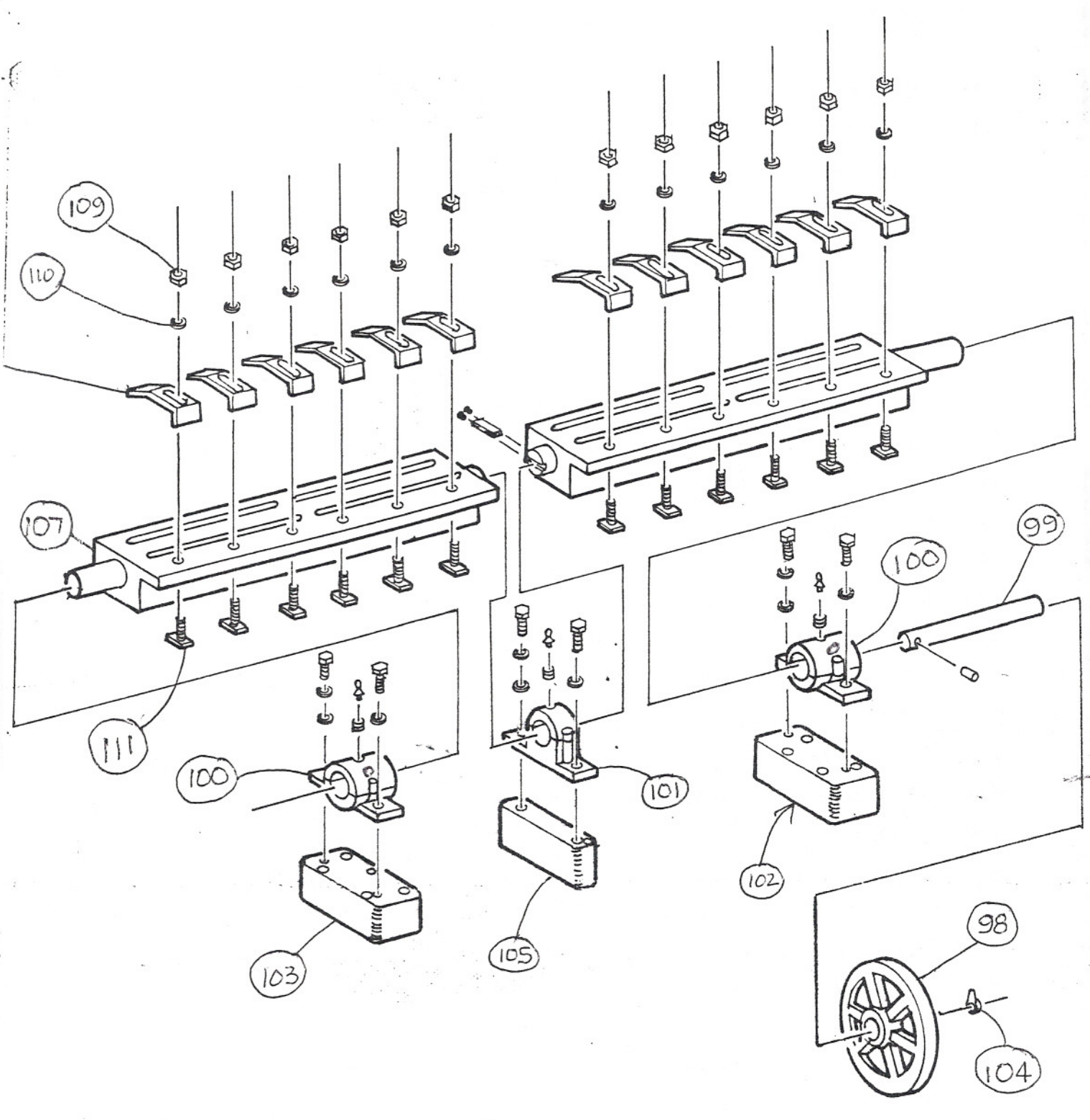

(14)

| | | | | | |
|------------|--|-----------|--|---------------|--|
| TITLE | | KNIFE BAR | | (84" Machine) | |
| DR. BY | | DATE | | SCALE | |
| CRISENBERY | | / / | | REF. LAYOUT | |
| CK'D | | DWG. NO. | | CHALLENGER | |
| SHT. | | | | | |

| | | |
|-----|----------|---|
| 112 | AAA0086Y | PUSHBUTTON - RED MUSHROOM HEAD |
| 113 | AAA0087J | PUSHBUTTON - RED EXTENDED HEAD |
| 114 | AAA0088T | PUSHBUTTON - GREEN FLUSH HEAD - ILLUMINATED |
| 115 | AAA0089C | SELECTOR SWITCH - BLUE ILLUMINATED |
| 116 | AAA0090S | SELECTOR SWITCH - GREEN ILLUMINATED |
| 117 | AAA0093E | POTENTIOMETER OPERATOR |
| 118 | AAA0096N | SELECTOR SWITCH - GREEN ILLUMINATED |
| 119 | AAA0130N | PUSHBUTTON - GREEN FLUSH HEAD |
| 120 | AAA0131W | PUSHBUTTON - GREEN FLUSH HEAD |
| 121 | AAC0018E | CONTROL BOARD - CARRIAGE DRIVE (SA00998S-1) |
| 122 | AAC0019A | CONTROL BOARD - DOWNFEED DRIVE (SA00999 -1) |
| 123 | AAF0024N | RESISTOR - 1/2HP PLUG-IN |
| 124 | AAF0025W | RESISTOR - 1/8HP PLUG-IN |
| 125 | AAF0093J | RESISTOR - 2.5KOHM 25W |
| 126 | AAF0052X | RESISTOR - 4.7KOHM 1/2W |
| 127 | AAN0013X | POTENTIOMETER - 5000 OHM |
| 128 | AAP0108E | CONNECTOR - UNIVERSAL TERMINAL |
| 129 | ABB0122H | STARTER - 3 PHASE MAGNETIC |
| 130 | ACC0005H | RECEPTACLE COVER - FLUSH PLUG |
| 131 | ACC0016X | UTILITY BOX |
| 132 | ACC0053D | SCREW COVER ENCLOSURE |
| 133 | ACC0122W | ENCLOSURE PANEL - 3 X 5 |
| 134 | ACC0123E | ENCLOSURE PANEL - 17 X 17 |
| 135 | AEE0037F | CONTROL RELAY |
| 136 | AEE0042A | TIME DELAY RELAY |
| 137 | AEE0043H | CONTROL RELAY |
| 138 | AGG0001Y | LIMIT SWITCH ROLLER ARM |
| 139 | AGG0002K | TERMINAL BLOCK MOUNTING RAIL |
| 140 | AGG0003W | RETAINING CLIP |
| 141 | AGG0004P | FUSE PULLER |
| 142 | AGG0005E | END BARRIER |
| 143 | AGG0006P | END BARRIER |
| 144 | AGG0016E | CLOSING BUTTON |
| 145 | AGG0019P | TERMINAL BLOCK |

| | | |
|-----|----------|--|
| 146 | AGG0023M | TERMINAL BLOCK |
| 147 | AGG0024V | TERMINAL BLOCK |
| 148 | AGG0090M | SINGLE OUTLET |
| 149 | AGG0110J | END BARRIER |
| 150 | AGG0142Z | OCTAL BASE |
| 151 | AKK0235G | 15AMP FUSE - DUAL ELEMENT |
| 152 | ASS0012X | AUXILLIARY CONTACT |
| 153 | AVV0044M | TRANSFORMER |
| 154 | AXX0003C | LIMIT SWITCH |
| 155 | CH-0087 | PUSHBUTTON BOX LEGEND |
| 156 | CH-0161 | ELECTRICAL ENCLOSURE - 20 X 20 X 8 |
| 157 | CH-0162 | TUBULAR SPACER |
| 158 | CH-0163 | CONTROLLER BOARD BRACKET |
| 159 | CH-0171 | PUSHBUTTON BOX MOUNTING BRACKET |
| 160 | PAA0002F | 3/8" FLEX CONNECTOR - STRAIGHT |
| 161 | PAA0004Y | 3/4" FLEX CONNECTOR - STRAIGHT |
| 162 | PAA0006A | 3/8" X 90 FLEX CONNECTOR - ELBOW |
| 163 | PAA0008K | 3/4" X 90 FLEX CONNECTOR - ELBOW |
| 164 | PAA0026G | 3/4" X 90 NON-METALLIC CONNECTOR - ELBOW |
| 165 | PAA0034A | 1/2" FLEX CONNECTOR - STRAIGHT |
| 166 | PDD0001B | 1/4-20 X 3/8" HEX SCREW |
| 167 | PDD0002J | 1/4-20 X 1/2" HEX SCREW |
| 168 | PDD0067C | 3/8-16 X 2-1/2" HEX SCREW |
| 169 | KNN0001K | FLEXIBLE SEALTITE CONDUIT |
| 170 | KNN0005D | FLEXIBLE SEALTITE CONDUIT |
| 171 | KNN0007H | FLEXIBLE NON-METALLIC CONDUIT |
| 172 | CH-0160 | PUSHBUTTON BOX |
| 173 | AEE0038Z | THERMAL OVERLOAD RELAY - 3PH BI-METALLIC |

| | | | |
|-----------------------|--|----------|-------------|
| TITLE | | | |
| ELECTRICAL COMPONENTS | | | |
| DR. BY | | DATE | SCALE |
| CRISENBERY | | / / | |
| CK'D | | | REF. LAYOUT |
| | | | CHALLENGER |
| SHT. | | DWG. NO. | |

20

| | | |
|-----|----------|---|
| 175 | MG-050 | KNIFE ALIGNING FIXTURE |
| 176 | PZZ0011L | 3/8" ALLEN WRENCH |
| 177 | PZZ0012Y | 5/16" ALLEN WRENCH |
| 178 | SA00470S | RA COOLANT - 1 GALLON <i>OR COOLRA201</i> |
| | SA00471K | RA COOLANT - 5 GALLON <i>OR COOLRA205</i> |

GRINDING WHEELS

10" X 3" X 1" RIM

| | | |
|----------|--------|-------------------------|
| HBB0003L | M165XO | RESINOID |
| HBB0004A | M34445 | VITRIFIED |
| HBB0006E | M74345 | PREMIUM VITRIFIED |
| HBB0005S | M46435 | VITRIFIED SUPER PREMIUM |

14" X 4" X 1-1/4" RIM

| | | |
|----------|--------|--------------------------|
| HBB0008C | M16445 | VITRIFIED |
| | M14445 | |
| HBB0011Z | M76445 | PREMIUM VITRIFIED |
| HBB0010G | M46435 | VITRIFIED SUPER PREMIUM |
| HBB0009P | M36450 | SPECIAL PREMIUM RESINOID |

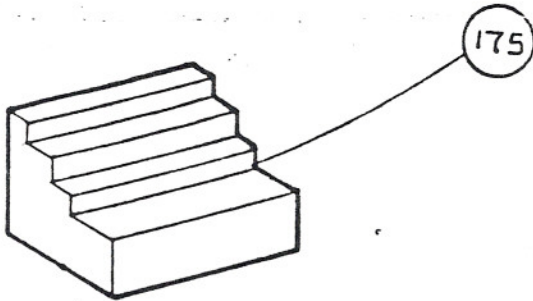
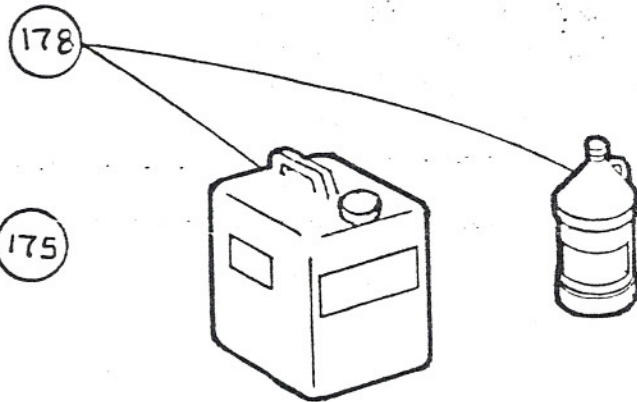
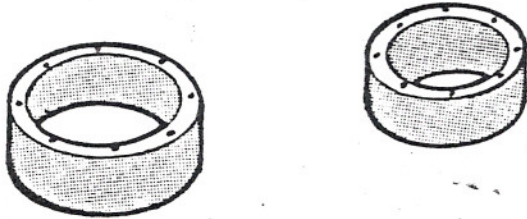
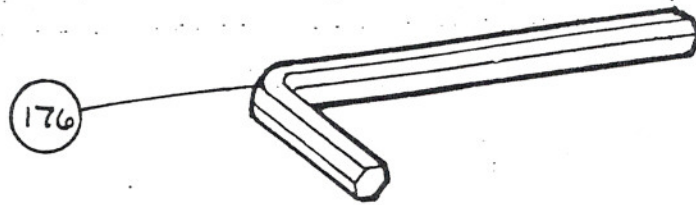
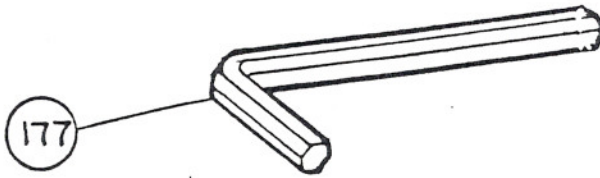

| | | | |
|-----------------|----------|-------|-------------|
| TITLE | | | |
| ACCESSORY PARTS | | | |
| DR. BY | DATE | SCALE | REF. LAYOUT |
| CRISENBERY | / / | | CHALLENGER |
| CK'D | DWG. NO. | | |
| SHT. | | | |

22