

IMPORTANT! Read and save these instructions. This manual to be left with the equipment.

2583703_C_EN_1812_Nortec-GS_IM



INSTALLATION MANUAL

Gas-fired Steam Humidifier
Nortec GS-Series



DANGER!

Fire or explosion hazard!

If the information in this manual is not followed exactly, a fire or explosion may result causing property damage, personal injury or loss of life.

DO NOT store or use gasoline or other flammable vapors and liquids in the vicinity of this or any other appliance.

WHAT TO DO IF YOU SMELL GAS

- DO NOT try to light any appliance.
- DO NOT touch any electrical switch.
- DO NOT use any phone in the building.
- Immediately call your gas supplier from a neighbor's phone. Follow the gas supplier's instructions.
- If you cannot reach your gas supplier, call the fire department.

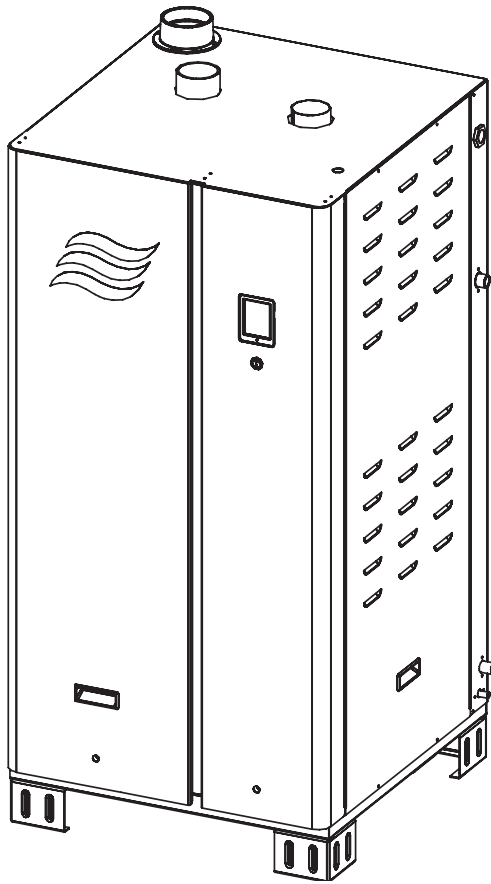

INSTALLATION MANUAL

Gas-fired Steam Humidifier
Nortec **GS Series**



Thank you for choosing Condair

Installation date (DD/MM/YYYY):

Commissioning date (DD/MM/YYYY):

Site:

Model:

Serial number:

Proprietary Notice

This document and the information disclosed herein are proprietary data of Condair Ltd. Neither this document, nor the information contained herein shall be reproduced, used, or disclosed to others without the written authorization of Condair Ltd., except to the extent required for installation, operation or maintenance of the customer's equipment.

Liability Notice

Condair Ltd. does not accept any liability due to incorrect installation, maintenance or operation of the equipment, or due to the use of parts/components/equipment that are not authorized by Condair Ltd.

Copyright Notice

© Condair Ltd, All rights reserved.

Technical modification rights reserved.

Contents

1	Introduction	7
1.1	Before You Start!	7
1.2	General	7
2	For Your Safety	9
3	Receiving and Storage	13
3.1	Inspection	13
3.2	Storage and Transportation	13
4	Product Overview	15
4.1	General Description	15
4.2	Model Designation	16
4.3	Model Specifications	17
4.4	Options	19
4.5	Accessories	19
5	Installation	21
5.1	General	21
5.2	Installation Overview	22
5.2.1	Typical Installation – Compact Units	22
5.2.2	Typical Installation – Full-Size Units	23
5.3	Site Requirements	24
5.4	Mounting the Humidifier	26
5.4.1	Clearances	26
5.4.1.1	Overall Dimensions and Weight	28
5.4.2	Standard Wall Mounting – Compact Unit Only	28
5.4.3	Standard Floor Stand Mounting – Compact Unit Only	31
5.4.4	Standard Mounting – Full-Size Unit	33
5.4.5	Optional Stand Mounting – Full-Size Unit	34
5.4.6	Mounting Checklist	35
5.5	Steam Connection	36
5.5.1	Installing the Main Steam Pipe	36
5.5.2	Best Practices for Installing Steam and Condensate Lines	37
5.5.2.1	Common Steam and Condensate Line Installation Mistakes	40
5.5.3	Steam Connection Checklist	41
5.6	Water Connections	42
5.6.1	Water Connections – Compact Unit	42
5.6.2	Water Connections – Full-Size Unit	43
5.6.3	Installing Exhaust Condensate Drain Line (CS/NX Model Only)	44
5.6.4	Water Connection Requirements	45
5.6.5	Water Connections Checklist	46
5.7	Combustion Air Connection	47
5.7.1	Space Air Installation	47
5.7.2	Sealed Combustion Installation	48
5.7.3	Combustion Air Checklist	49
5.8	Exhaust Vent Connection	50
5.8.1	General Requirements	50

5.8.2	Exhaust Vent Installation for CS/NX Model	56
5.8.2.1	Installation as a Category IV Appliance	56
5.9	Gas Connection	58
5.9.1	Gas Connection, Compact and Full-Size Unit	58
5.9.2	Gas Connection Requirements	59
5.9.3	Gas Leakage Test	59
5.9.4	Gas Connection Checklist	60
5.10	Humidity Control Systems	61
5.10.1	Control Device Locations	61
5.10.2	Permissible Control Signal Inputs	62
5.11	Electrical Connections	63
5.11.1	General	63
5.11.2	Wiring Diagrams	64
5.11.2.1	Nortec GS 50/100/150/200/300/450/600	64
5.11.2.2	Nortec GS 450/600	65
5.11.3	External Connections	66
5.11.3.1	External Security Loop	66
5.11.3.2	Modulating Demand or Humidity Signal	67
5.11.3.3	On/Off Humidistat Signal	68
5.11.3.4	Full Tank Blowdown Signal Connection	68
5.11.3.5	Remote Fault PCB Connections	69
5.11.3.6	Single-Phase Power Supply Connection	70
5.11.3.7	Modbus Connection	71
5.11.4	Connecting Multiple Units Using Linkup	72
5.11.5	Electrical Connections Checklist	73
6	Product Specifications	74
6.1	Weights	74
6.2	Dimensions	74
A	Appendix	80
A.1	Installation Checklist	80
B	Appendix	84
B.1	Commissioning Checklist	84
B.1.1	Pre-Start-Up Checklist	84
B.1.2	Performance Checklist	88

1 Introduction

1.1 Before You Start!

Thank you for purchasing the Nortec GS humidifier.

The Nortec GS humidifier incorporates the latest technical advances and meets all recognized safety standards. Never-the-less, improper use of the Nortec GS humidifier may result in danger to the user or third parties, and/or damage to property.

To ensure safe, proper and economical operation of the Nortec GS humidifier, observe and comply with all information and safety instructions contained in this manual, as well as all relevant documentation of components of the installed humidification system. Comply with all local and regional regulations dealing with gas, combustion air, flue gases, water, steam and electrical installations.

You can find the latest updates to our manuals on our website, <https://www.humidity.com>. If you have additional questions, contact your Condaire representative. They will be glad to assist you.

1.2 General

Limitations

The subject of this manual is the Nortec GS humidifier. The various options and accessories may only be described in-so-far as is necessary for proper installation and operation of the equipment. Additional information on available options and accessories can be obtained in the instructions that are supplied with them.

This manual is restricted to the installation of the Nortec GS humidifier, and is intended for well trained personnel who are suitably qualified for their respective tasks.

Symbols Used in This Manual



CAUTION!

The catchword "CAUTION" in conjunction with the general caution symbol is used to provide safety instructions that, if neglected, may cause damage and/or malfunction of the unit or damage to property.



WARNING!

The catchword "WARNING" in conjunction with the general warning symbol is used to provide safety instructions that, if neglected, may cause injury to personnel. Other specific warning symbols may also be used in place of the general symbol.



DANGER!

The catchword "DANGER" in conjunction with the general danger symbol is used to provide safety instructions that, if neglected, may cause severe injury to personnel or even death. Other specific danger symbols may also be used in place of the general symbol.

Other Related Publications

This manual is supplemented by other publications such as the Operation and Maintenance Manual, Spare Parts List, etc., which are included in the delivery of the equipment. Where necessary, appropriate cross-references to these publications have been added in this manual.

Storage of Manual

Keep this manual in a place where it is safe and readily accessible. If the equipment is moved to another location, make sure that the manual is passed on to the new user.

If the manual is lost or misplaced, contact your Condair representative for a replacement copy.

Language Versions

This manual is also available in other languages – contact your Condair representative.

2 For Your Safety

General

Every person who is tasked with the installation of the Nortec GS humidifier must read and understand this manual before performing any work on the unit. Knowing and understanding the contents of the Installation Manual, and the Operation and Maintenance Manual is a basic requirement for protecting personnel against any kind of danger, preventing faulty operation, and operating the unit safely and correctly.

All labels, signs and markings applied to the Nortec GS humidifier must be observed and kept in a readable state.

Personnel Qualifications

All procedures described in this manual must only be performed by personnel who are adequately qualified, well trained and are authorized by the customer.

For safety and warranty reasons, any activity beyond the scope of this manual must only be performed by qualified personnel authorized by Condaire.

All personnel working with the Nortec GS humidifier must be familiar with, and comply with the appropriate regulations on workplace safety and prevention of accidents.

Intended Use

The Nortec GS humidifier is intended exclusively for air humidification using a Condaire-approved steam distributor within specified operating conditions (refer to the Operation and Maintenance Manual for details). Any other type of application, without the express written consent of Condaire, is considered to be NOT conforming to its intended purpose, and may lead to dangerous operation and will void the warranty.

In order to operate the equipment in the intended manner all information contained in this manual, in particular the safety instructions, must be observed closely.

Safety Precautions that Must be Observed



DANGER!
Risk of electric shock!

The Nortec GS humidifier is mains powered. Live parts may be exposed when the access panels are removed. Touching live parts may cause severe injury or even death.

Prevention: The Nortec GS humidifier must be connected to the mains only after all installation work has been completed, checked for correct workmanship, and the access panels are installed properly and fastened securely.



DANGER!
Risk of fire or explosion!

The Nortec GS is a gas-fired humidifier. Improper installation, adjustment, alteration, service, maintenance or use can cause carbon monoxide poisoning, explosion, fire or other hazards that can cause serious injury, death or property damage.

If over-heating occurs or if the gas fails to shut off: Shut off the gas supply at the manual gas shutoff valve before shutting off the electrical power supply.

DO NOT use this appliance if any part has been under water. Call a qualified service technician immediately to inspect and replace any part of the control system or gas control that has been under water.

Any work on the gas system must only be performed by a qualified installer, service agency or your local gas supplier. Use only factory-authorized and listed kits or accessories when installing or modifying this appliance.

DO NOT store or use gasoline or other flammable vapors and liquids in the vicinity of the humidifier or any other appliance.

What to do if You Smell Gas:

DO NOT try to light any appliance.

DO NOT touch any electrical switch.

DO NOT use any phone in the building.

Leave the building immediately.

Call your gas supplier immediately from a location far away from the building with the gas leak.

Follow the gas supplier's instructions.

If you cannot reach your gas supplier, call the fire department.



WARNING!
Risk of severe burns from contact with hot steam vapors!

The Nortec GS humidifier produces hot steam vapors for humidification. Bare skin in contact with hot steam vapors can result in severe burns.

Prevention: Avoid contact with steam vapors, or wear appropriate personal protective equipment when working near steam vapors.



WARNING!
Risk of severe burns from contact with hot surfaces!

The water tank, steam line and exhaust system in the Nortec GS humidifier get very hot during operation. Bare skin in contact with hot surfaces can result in severe burns.

Prevention: Shut down the humidifier and wait for it to cool down to room temperatures before touching these surfaces, or wear appropriate personal protective equipment.

Preventing Unsafe Operation

All personnel working with the Nortec GS humidifier must immediately report to the customer any alterations to the unit that may affect safety, and **secure the humidifier against accidental power-up.**

Modifications to the Unit Prohibited

Modifications are NOT permitted on the Nortec GS humidifier without the express written consent of Condaire.

The location of the various safety labels on the Nortec GS humidifier is shown in *Figure 1*.

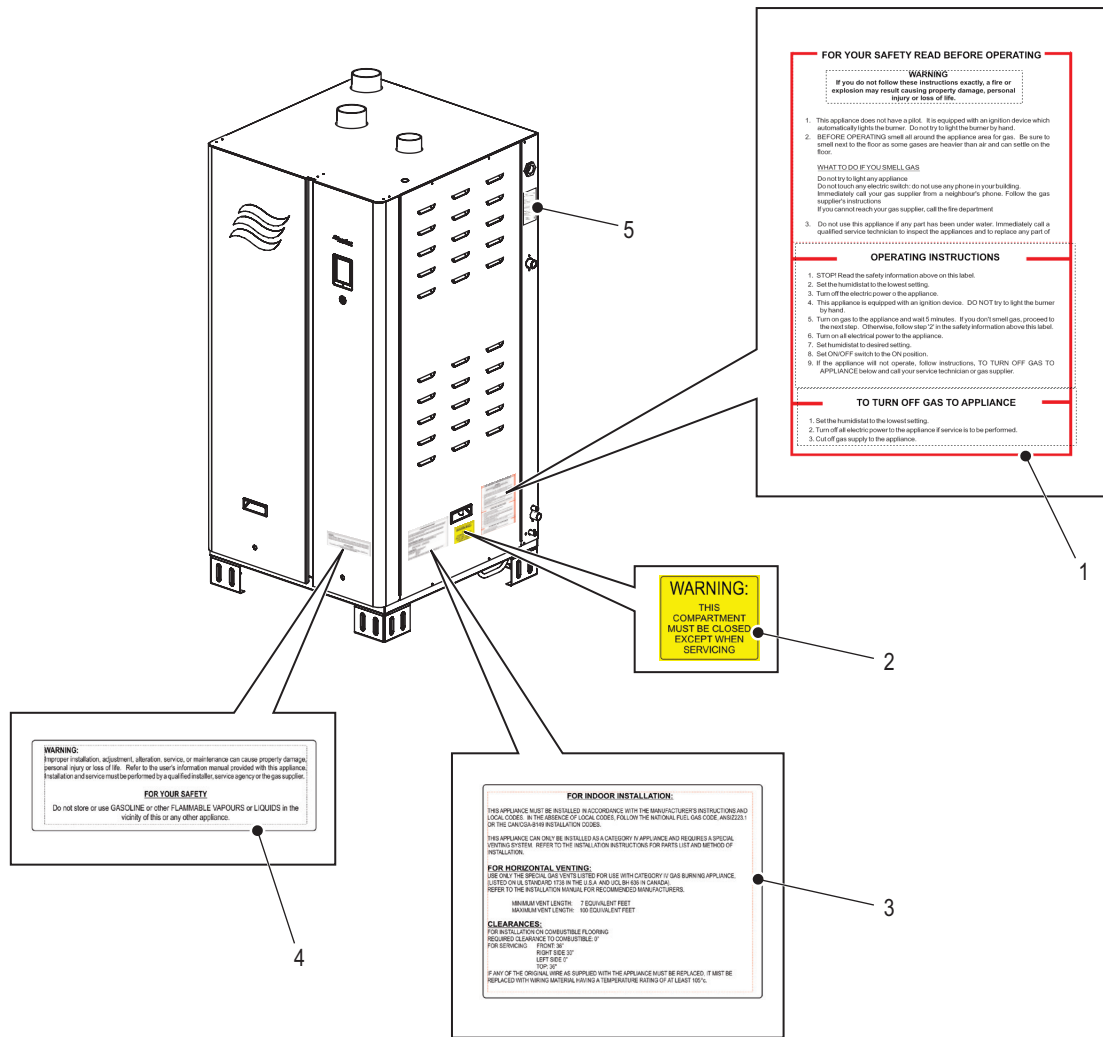

Figure 1: Safety Labels

- 1 Label, gas safety warning
- 2 Label, keep cabinet closed warning
- 3 Label, installation guidelines
- 4 Label, general safety warning
- 5 Label, specification

This page intentionally left blank

3 Receiving and Storage

3.1 Inspection

All Condaire products are shipped F.O.B at the factory. All damage, breakage or loss claims are the responsibility of the shipping company.

After receiving the shipment, inspect the goods as follows:

- Inspect the shipping boxes for damage. Report any shipping box damages to the shipping company without delay.
- Check the goods against the packing slip to ensure that all items have been delivered. Report any shortages to your Condaire representative within 48 hours of receipt of the goods. Condaire does not assume responsibilities for any shortages beyond this period.
- Unpack the parts/components and check for any damage.
If parts/components are damaged, notify the shipping company immediately.
- Verify the model type on the specification label to ensure that it is suitable for your installation. Refer to [Figure 3 on page 16](#).

3.2 Storage and Transportation

Storage

Store the Nortec GS humidifier in its original packaging inside a protected area that meets the following requirements until it is installed. These requirements also apply if the unit needs to be stored for an extended period of time.

- Room temperature: 41 to 104°F (5 to 40°C)
- Room humidity: 10 to 75% RH

Transportation

For optimum protection always transport the unit and components in their original packaging, and use appropriate lifting/transporting devices.

Packaging

Keep the original packaging of the unit/components for later use.

If the packaging needs to be disposed off, observe local regulations on waste disposal. Recycle packaging where possible.

This page intentionally left blank

4 Product Overview

4.1 General Description

The Nortec GS series is a completely new design of gas-fired steam humidifiers. It is designed to provide clean steam humidification at an economical price. The Nortec GS humidifier is available in condensing high-efficiency (CS), and ultra-low NOx condensing (NX) models in capacities ranging from 50 lb/h (23 kg/h) to 600 lb/h (260 kg/h). The CS and NX models are classified as Category IV appliances.

The Nortec GS humidifier comes in two housing styles – compact (50-100 lb/h (23-45 kg/h)), and full-size (150-600 lb/h (65-260 kg/h)). Refer to [Figure 2](#).

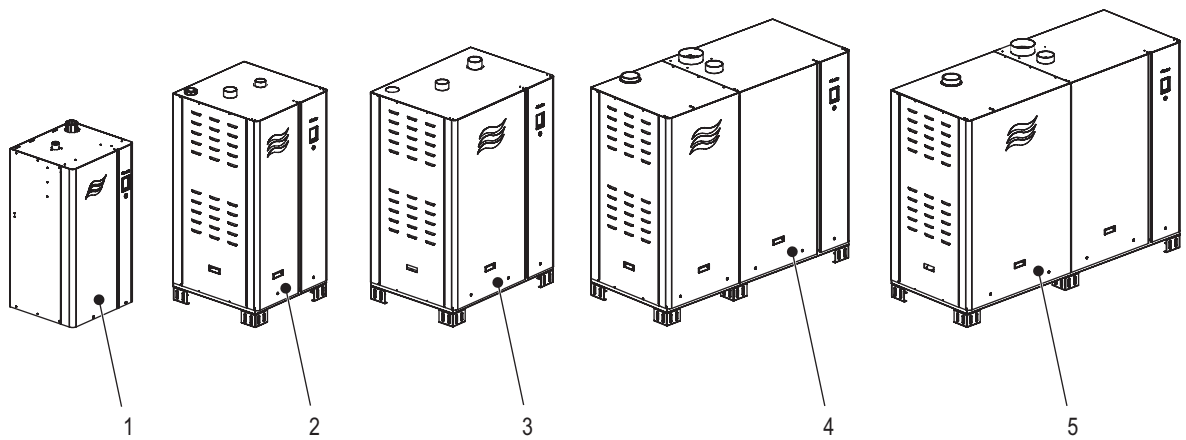

Figure 2: Nortec GS Series Humidifiers

- 1 GS 50/100 (compact housing)
- 2 GS 150 (full-size housing)
- 3 GS 200/300 (full-size housing)
- 4 GS 450 (full-size housing)
- 5 GS 600 (full-size housing)

4.2 Model Designation

The specification label on the right side of the Nortec GS humidifier shows its model number, serial number and ratings – refer to [Figure 3](#).

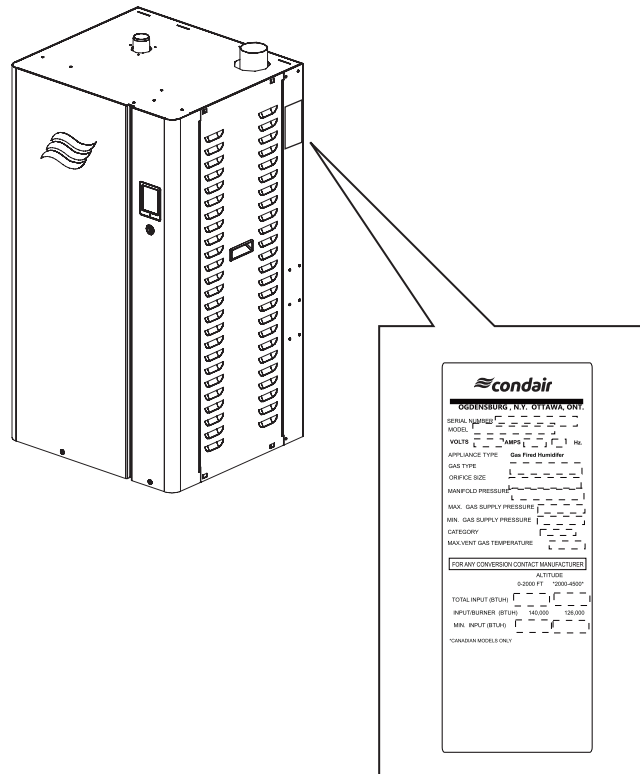
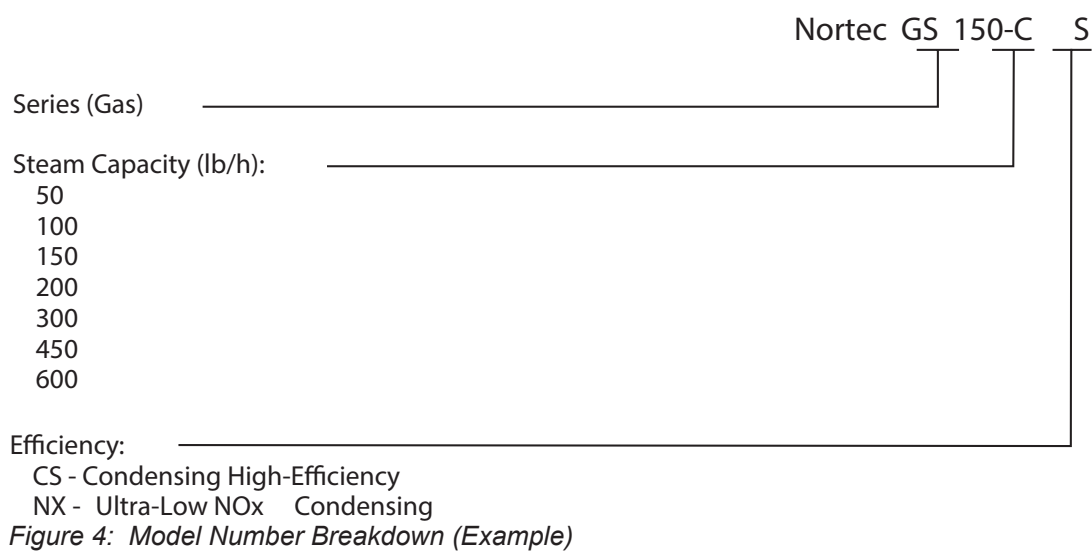

Figure 3: Nortec GS Humidifier Specification Label

The breakdown of the model number is shown in [Figure 4](#).



4.3 Model Specifications

Table 1 and Table 2 on page 18 list the specifications for the Nortec GS humidifier. Also, refer to "High Altitude De-rating" on page 19 for high altitude de-rating of the Nortec GS humidifier

Condensing High-efficiency (CS) Model Specifications

Table 1: Condensing High-Efficiency (CS) Model Specifications

Fuel	Blower Speed	Input BTUh (kW)	Steam Capacity lb/h (kg/h)	Manifold Pressure in H ₂ O (Pa)
Model GS 50-CS				
Natural gas	Maximum	62,000 (18.2)	50 (23)	-0.01 (-2.5)
	Minimum	12,400 (3.6)	10 (4.5)	-0.01 (-2.5)
Propane	Maximum	62,000 (18.2)	50 (23)	-0.01 (-2.5)
	Minimum	13,000 (3.8)	10 (4.5)	-0.01 (-2.5)
Model GS 100-CS				
Natural gas	Maximum	124,000 (36.3)	100 (45)	-0.01 (-2.5)
	Minimum	24,800 (7.3)	20 (9)	-0.01 (-2.5)
Propane	Maximum	124,000 (36.3)	100 (45)	-0.01 (-2.5)
	Minimum	24,800 (7.3)	20 (9)	-0.01 (-2.5)
Model GS 150-CS				
Natural gas	Maximum	186,000 (54.5)	150 (68)	-0.01 (-2.5)
	Minimum	37,200 (10.9)	30 (13.6)	-0.01 (-2.5)
Propane	Maximum	186,000 (54.5)	150 (68)	-0.01 (-2.5)
	Minimum	37,200 (10.9)	30 (13.6)	-0.01 (-2.5)
Model GS 200-CS				
Natural gas	Maximum	248,000 (72.7)	200 (91)	-0.01 (-2.5)
	Minimum	24,800 (7.3)	20 (9)	-0.01 (-2.5)
Propane	Maximum	248,000 (72.7)	200 (91)	-0.01 (-2.5)
	Minimum	24,800 (7.3)	20 (9)	-0.01 (-2.5)
Model GS 300-CS				
Natural gas	Maximum	372,000 (109.0)	300 (136)	-0.01 (-2.5)
	Minimum	37,200 (10.9)	30 (13.6)	-0.01 (-2.5)
Propane	Maximum	372,000 (109.0)	300 (136)	-0.01 (-2.5)
	Minimum	37,200 (10.9)	30 (13.6)	-0.01 (-2.5)
Model GS 450-CS				
Natural gas	Maximum	558,000 (163.5)	450 (204)	-0.01 (-2.5)
	Minimum	37,200 (10.9)	30 (13.6)	-0.01 (-2.5)
Propane	Maximum	558,000 (163.5)	450 (204)	-0.01 (-2.5)
	Minimum	37,200 (10.9)	30 (13.6)	-0.01 (-2.5)
Model GS 600-CS				
Natural gas	Maximum	744,000 (218.0)	600 (272)	-0.01 (-2.5)
	Minimum	37,200 (10.9)	30 (13.6)	-0.01 (-2.5)
Propane	Maximum	744,000 (218.0)	600 (272)	-0.01 (-2.5)
	Minimum	37,200 (10.9)	30 (13.6)	-0.01 (-2.5)

Ultra-Low NOx Condensing (NX) Model Specifications

Table 2: Ultra-Low NOx Condensing (NX) Model Specifications

Fuel	Blower Speed	Input BTUh (kW)	Steam Capacity lb/h (kg/h)	Manifold Pressure in H2O (Pa)
Model GS 50-NX				
Natural gas	Maximum	65,000 (19.0)	50 (23)	-0.01 (-2.5)
	Minimum	13,000 (3.8)	10 (4.6)	-0.01 (-2.5)
Model GS 100-NX				
Natural gas	Maximum	120,000 (35.2)	100 (45)	-0.01 (-2.5)
	Minimum	26,000 (7.6)	20 (9)	-0.01 (-2.5)
Model GS 150-NX				
Natural gas	Maximum	187,500 (55.0)	150 (68)	-0.01 (-2.5)
	Minimum	39,000 (11.4)	30 (13.6)	-0.01 (-2.5)
Model GS 200-NX				
Natural gas	Maximum	240,000 (70.3)	200 (91)	-0.01 (-2.5)
	Minimum	26,000 (7.6)	20 (9)	-0.01 (-2.5)
Model GS 300-NX				
Natural gas	Maximum	375,000 (109.9)	300 (136)	-0.01 (-2.5)
	Minimum	39,000 (11.4)	30 (13.6)	-0.01 (-2.5)
Model GS 450-NX				
Natural gas	Maximum	562,500 (164.9)	450 (204)	-0.01 (-2.5)
	Minimum	39,000 (11.4)	30 (13.6)	-0.01 (-2.5)
Model GS 600-NX				
Natural gas	Maximum	750,000 (219.8)	600 (272)	-0.01 (-2.5)
	Minimum	39,000 (11.4)	30 (13.6)	-0.01 (-2.5)

High Altitude De-rating

All high altitude installations have a de-rating of the input capacity. All Canadian models have an automatic 10% de-rating for installations between altitudes of 2000-4500 ft (610-1372 m). For U.S. models, refer to [Table 3](#) for the applicable de-ratings.

Table 3: High Altitude De-rating

Altitude		De-rating (%)
Feet (ft)	Meters (m)	
0-2000	0-610	0
2001-3000	610-915	8
3001-4000	915-1220	12
4001-4500	1220-1370	16
4501 and higher	1370 and higher	Contact factory

4.4 Options

[Table 4](#) shows the options for the Nortec GS humidifier. Contact your Condair representative for details.

Table 4: Nortec GS Series Options

Option	Application
Natural gas or propane	Factory-installed gas valve for using either natural gas or propane in the Nortec GS humidifier. Note: only CS models can be configured for propane.

4.5 Accessories

[Table 5](#) shows the accessories for the Nortec GS humidifier. Contact your Condair representative for details.

Table 5: Accessories for the Nortec GS Series

Accessory	Application
Steam distributor – ASD, BSD, CSD	Steam distribution system for use in an air duct.
SAM-e steam distribution manifold, and mini SAM-e	Steam distribution system for use in an air duct where reduced absorption distance is required.
Blower pack (remote-mounted)	For direct room humidification or use in conditioned spaces without a built-in air distribution system. The Nortec GS can use a remote-mounted blower pack for steam distribution (blower pack ordered as an accessory). Larger Nortec GS units require multiple blower packs.
Digital or analog control humidistat with either On/Off or modulating operation	Input device used to meter the output of the humidifier based on the sensed relative humidity. The humidistat can be installed in the conditioned space that is being humidified, or within the duct.
Digital RH transducer	Input device used to communicate the relative humidity in a conditioned space or a duct to the humidifier.
Digital or analog high limit humidistat with either On/Off or modulating operation	Input device used to limit the output of the humidifier by either shutting it down or throttling it down when the humidity in the duct approaches the high limit.
Air proving switch	Input device to ensure that humidification only occurs when air is moving through the duct.
Outdoor temperature sensor	Input device used to communicate the outdoor temperature to the humidistat so that it can lower the setpoint value during cold weather to prevent condensation on exterior windows/surfaces.
Mounting stand	(Required) Stand for independent mounting of the Nortec GS humidifier on the floor.

This page intentionally left blank

5 Installation

5.1 General

Strictly observe all instructions and perform all tasks (including the mounting of the unit and connection of the gas, flue gas, water, steam and power supplies) as described in this manual.

Adhere to all local and national codes dealing with gas, combustion air, flue gas, water, steam and electrical installations. In the absence of local codes, the installation must conform to the ANSI Z223.1, National Fuel Gas Code, and/or CSA B149.1 codes.

Condair does not accept any liability for installation of humidification equipment by unqualified personnel, or the use of equipment/parts that are not authorized by Condair.

Personnel Qualifications

All installation work must be performed only by licensed personnel authorized by the customer. It is the customer's responsibility to verify qualifications of the personnel.

Safety

Observe the following safety precautions:



DANGER!
Risk of explosion and fire!

The Nortec GS is a gas-fired humidifier. Improper installation, adjustment, alteration, service, maintenance or use can cause carbon monoxide poisoning, explosion, fire or other hazards that can cause serious injury, death or property damage. If assistance is required, contact a qualified installer, service agency or your local gas supplier.

Use only factory-authorized and listed kits or accessories when installing or modifying this appliance.



DANGER!
Risk of electric shock!

The Nortec GS humidifier is mains powered. Live parts may be exposed when the access panels are removed. Touching live parts may cause severe injury or even death.

Prevention: The Nortec GS humidifier must be connected to the mains only after all installation work has been completed, checked for correct workmanship, and the access panels are installed properly and fastened securely.



CAUTION!
Risk of damage to internal components from electrostatic discharge (ESD)!

The electronic components inside the humidifier are sensitive to electrostatic discharge (ESD).

Prevention: Take appropriate measures to protect the electronic components inside the unit against damage caused by electrostatic discharge (ESD). Refer to ANSI/ESD-S20.20.

5.2 Installation Overview

5.2.1 Typical Installation – Compact Units

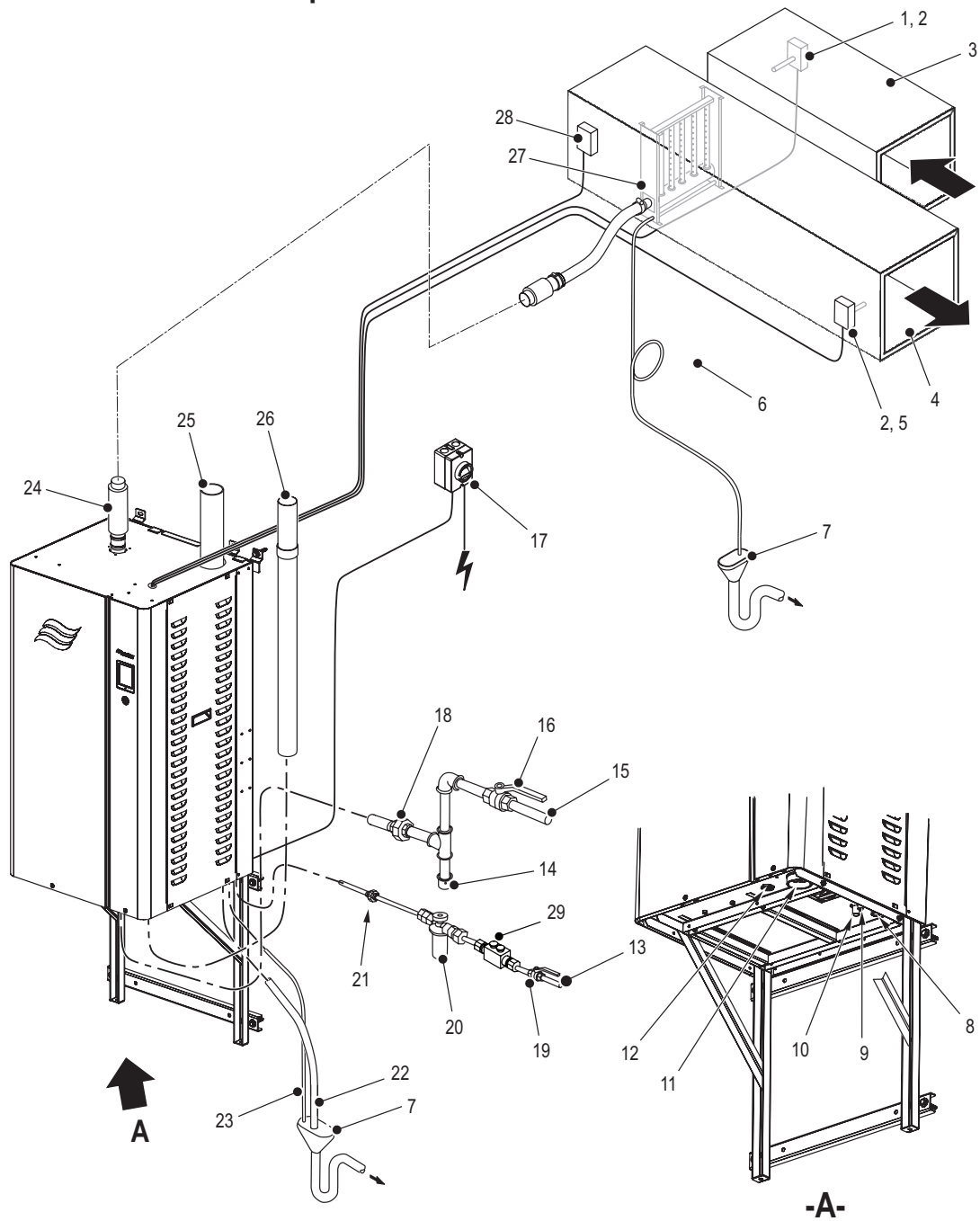

Figure 5: Installation Overview – Compact Unit

- | | | | |
|----|--|----|--|
| 1 | Humidistat, On/Off (used for humidity control) | 15 | Supply line, gas |
| 2 | Humidity sensor or modulating humidistat (used for control of the space in the return duct, high limit in the supply duct) | 16 | Valve, manual gas shutoff |
| 3 | Duct, return air | 17 | Switch, disconnect, electrical fused (dedicated) |
| 4 | Duct, supply air | 18 | Fitting, union |
| 5 | Humidistat, On/Off, high limit (external security loop) | 19 | Valve, water shutoff |
| 6 | Drain line, condensate (with trap) | 20 | Filter, water (optional, but recommended) |
| 7 | Funnel, air gap (with optional trap) | 21 | Fitting, union |
| 8 | Inlet, water | 22 | Drain line |
| 9 | Outlet, condensate drain | 23 | Drain line, exhaust condensate (CS/NX model only) |
| 10 | Outlet, drain | 24 | Steam line |
| 11 | Inlet, intake air | 25 | Vent, exhaust (connected to exterior) |
| 12 | Inlet, gas | 26 | Vent, air intake (connected to exterior – optional) |
| 13 | Supply line, water | 27 | Distributor, steam |
| 14 | Trap, sediment | 28 | Switch, air proving (external security loop) |
| | | 29 | Double check valve backflow preventer (supplied by others) |

5.2.2 Typical Installation – Full-Size Units

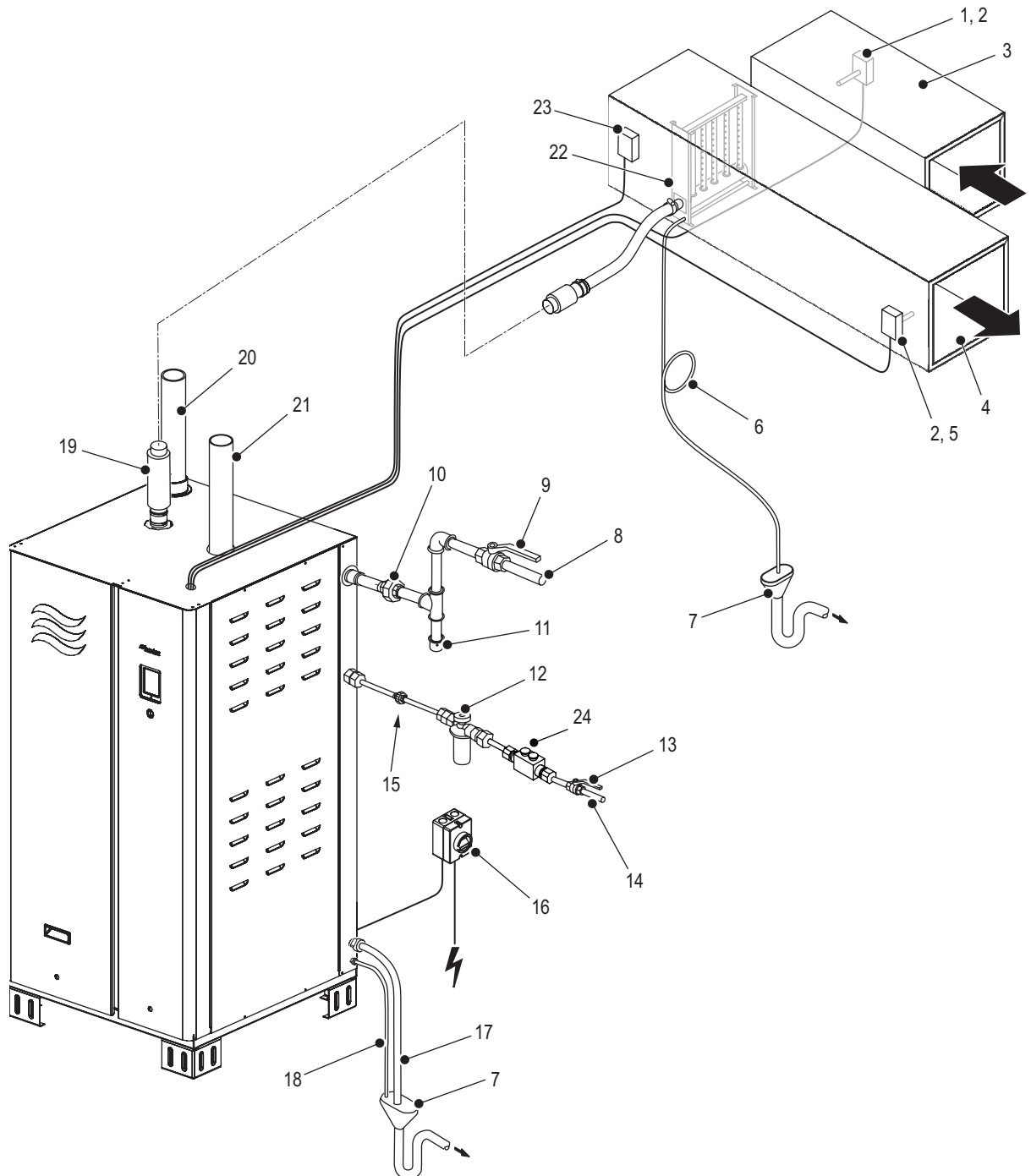

Figure 6: Installation Overview – Full-Size Units (GS 150 Shown)

- | | | | |
|----|--|----|--|
| 1 | Humidistat, On/Off (used for humidity control) | 13 | Valve, water shutoff |
| 2 | Humidity sensor or modulating humidistat (used for control of the space in the return duct, high limit in the supply duct) | 14 | Supply line, water |
| 3 | Duct, return air | 15 | Fitting, union |
| 4 | Duct, supply air | 16 | Switch, disconnect, electrical fused (dedicated) |
| 5 | Humidistat, On/Off, high limit (external security loop) | 17 | Drain line |
| 6 | Drain line, condensate (with trap) | 18 | Drain line, exhaust condensate (CS/NX model only) |
| 7 | Funnel, air gap (with optional trap) | 19 | Steam line |
| 8 | Supply line, gas | 20 | Vent, air intake (connected to exterior – optional) |
| 9 | Manual gas shutoff valve | 21 | Vent, exhaust vent (connected to exterior) |
| 10 | Fitting, union | 22 | Distributor, steam |
| 11 | Trap, sediment | 23 | Switch, air proving (external security loop) |
| 12 | Filter, water (optional, but recommended) | 24 | Double check valve backflow preventer (supplied by others) |

5.3 Site Requirements

In preparation for installation of the Nortec GS humidifier ensure that the following site requirements are satisfied. Report any discrepancies to the site engineer.

Steam and Condensate Lines

- The location of the Nortec GS humidifier is largely dependent on the location of the steam distributor, the exhaust vent pipe and the air intake pipe. To minimize heat loss through the steam line, choose the location of the humidifier so that it is as close as possible to the steam distributor.
- Keep the length of the steam line as short as possible. When possible, install the humidifier below the steam distributor. Make sure that the selected location permits proper routing of steam and condensate lines. Refer to [“Best Practices for Installing Steam and Condensate Lines” on page 37](#) for details.

Mounting

- The space in which the humidifier is to be installed must allow adequate clearances for ease of maintenance, and must be easily accessible for servicing. Refer to [“Clearances” on page 26](#) for the required and suggested clearances. Adhere to all local and national installation codes. Condaire is not responsible for any installation code violations.
- The Nortec GS humidifier is designed to be floor-mounted, with the exception of the GS 50/100 unit which comes with a floor stand that also converts to mounting bracket for wall-mounting. The GS 150-600 units can also be mounted on an optional floor stand. The floor must be level if mounting the unit on the floor. If wall-mounting the compact unit, choose a wall or other suitable vertical surface that offers a sufficiently high load-bearing capacity – refer to maximum operating weight in [Table 11 on page 28](#). In addition, the mounting surface must be able to withstand temperatures of 140-158 °F (60-70 °C) that can be generated during operation of the humidifier. Care must also be taken to ensure that the unit is not mounted above sensitive equipment or walkways.
- Do not mount the humidifier on wooden floors, carpeting or near combustible materials. Adhere to all local and national installation codes.
- Do not mount the humidifier on vibrating surfaces, or near hot surfaces or surfaces that can freeze.
- The Nortec GS humidifier must be installed in a drip-proof location within buildings, where the ambient temperature is 41-104 °F (5-40 °C) and the relative humidity is 5-80% (non-condensing). The selected location must also protect all electrical components in the humidifier from water damage.

Water Supply

- The water supply to the humidifier must be cold potable drinking water, reverse osmosis (RO) water or de-ionized water (DI), with a flow rate of 2.6 gpm (10 L/min) for Nortec GS 50-300 unit or 5.3 gpm (20 L/min) for Nortec GS 450/600 unit. The water quality requirements are listed in [Table 6](#).

Table 6: Water Quality Requirements

Water Type	Hardness gpg (PPM)	Alkalinity (pH)	Chloride (PPM)
Potable	0-15 (0-256)	5-8	0-50
Treated	0-0.99 (0-17)	5-8	0-50

- The water supply line to the humidifier must have a minimum diameter of 1/2 in (13 mm) with a 1/2 in NPT female end. The line must also have a shutoff valve and a union fitting for ease of maintenance.
- The water supply should be filtered to 5 µm (optional, but recommended) and pressure regulated to 30-80 psig (207-550 kPa). If necessary, a surge arrestor should be installed if pressure surges occur.
- For best performance, water temperature should be 34-59 °F (1-15°C), and maximum temperature must not exceed 77 °F (25 °C).
- The water from the tank may flow back to the water source. To prevent backflow from the unit to the water supply, install a double check valve backflow preventer. Adhere to all local and national installation regulations.
- The water supply pipe can be made of plastic that is pressure-proof and certified for use with drinking

water systems, copper (not permitted for DI water) or stainless steel (minimum DIN 1.4301).

- The water supply should be free of additives such as corrosion inhibitors, disinfectants, etc., which may affect the performance of the humidifier.

Drainage

- The humidifier should be connected to a dedicated building drain (recommended) with a minimum drainage rate of 5.3 gpm (20 L/min). The drain line must allow free and easy drainage.
- The building drain pipe should be made of a material rated to handle high temperature discharge water at 212 °F (100 °C).
- The space in which the humidifier is to be installed should have a floor drain connected to the building drain. However, if a floor drain is not available, a leakage monitoring device must be supplied to permit interruption of the water supply in case of a leakage. A drain pan is also recommended to prevent property damage.

Combustion Air

- The space in which the humidifier is to be installed must have access to a good supply of clean combustion air at atmospheric pressure. Adhere to appropriate local and national installation regulations for sealed combustion and space air installations.
- The maximum temperature of the combustion air supply should be 86°F (30°C).
- For additional requirements for sealed combustion and space air installations refer to [“Combustion Air Connection” on page 47](#).

Exhaust Venting

- The space in which the humidifier is to be installed must permit routing of exhaust air to the outside. Adhere to all local and national installation regulations.
- For additional requirements for the different types of exhaust vent installations refer to [“Exhaust Vent Connection” on page 50](#).

Gas Supply

- Gas supply to the unit must be equipped with a certified manual gas shutoff valve located in the immediate vicinity of the humidifier.
- If black pipe is used, a sediment trap (located between the manual shutoff valve and the unit) must also be supplied.
- A capped 1/8 in NPT test port must be supplied in the gas line immediately upstream from the humidifier gas connection.
- A union fitting must be supplied in the gas line immediately upstream from the humidifier gas connection.
- The operating pressure of the gas supply to the humidifier must be as listed in [Table 7](#).

Table 7: Gas Operating Pressure

Gas Type	Operating Pressure	
	Minimum	Maximum
Natural gas (North America)	5 in H2O (1.25 kPa)	10.0 in H2O (2.49 kPa)
Propane (North America)	9.0 in H2O (2.24 kPa)	14.0 in H2O (3.49 kPa)

- The gas supply line must be sized as listed in [Table 8](#). The pipe connection should have male NPT threads.

Table 8: Gas Line Size

Model	Minimum Gas Line Size	Gas Inlet Size (Female)
GS 50	1/2 in (15 mm)	1/2 in NPT
GS 100	1/2 in (15 mm)	1/2 in NPT
GS 150	3/4 in (20 mm)	3/4 in NPT
GS 200	1 in (25 mm)	1 in NPT
GS 300	1 in (25 mm)	1 in NPT
GS 450	1-1/4 in (32 mm)	1 in NPT
GS 600	1-1/4 in (32 mm)	1 in NPT

Power Supply

- The power supply to the humidifier must not exceed the rated current draw indicated on the specification label. Refer to [Figure 3 on page 16](#).
- The power supply must have an external dedicated fused disconnect switch located in the immediate vicinity of the humidifier. The **fusing must be a slow-blow fuse and not exceed the maximum current draw of 15 A**.
- If a remote-mounted blower pack is used for steam distribution, an external 120 VAC, 15 A power source must be supplied.

5.4 Mounting the Humidifier

Before mounting the Nortec GS humidifier, refer to [“Site Requirements” on page 24](#) for the location and mounting requirements.

5.4.1 Clearances

The required clearances are listed in [Table 9 on page 28](#), and the suggested clearances are listed in [Table 10 on page 28](#). Refer to [Figure 7](#). Consult local and national installation regulations. Condair does not accept responsibility for violations of the installation codes.

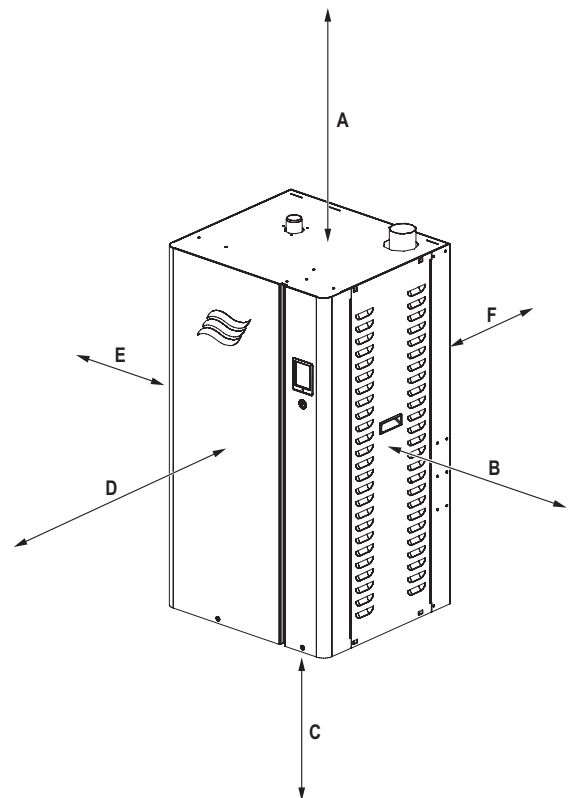
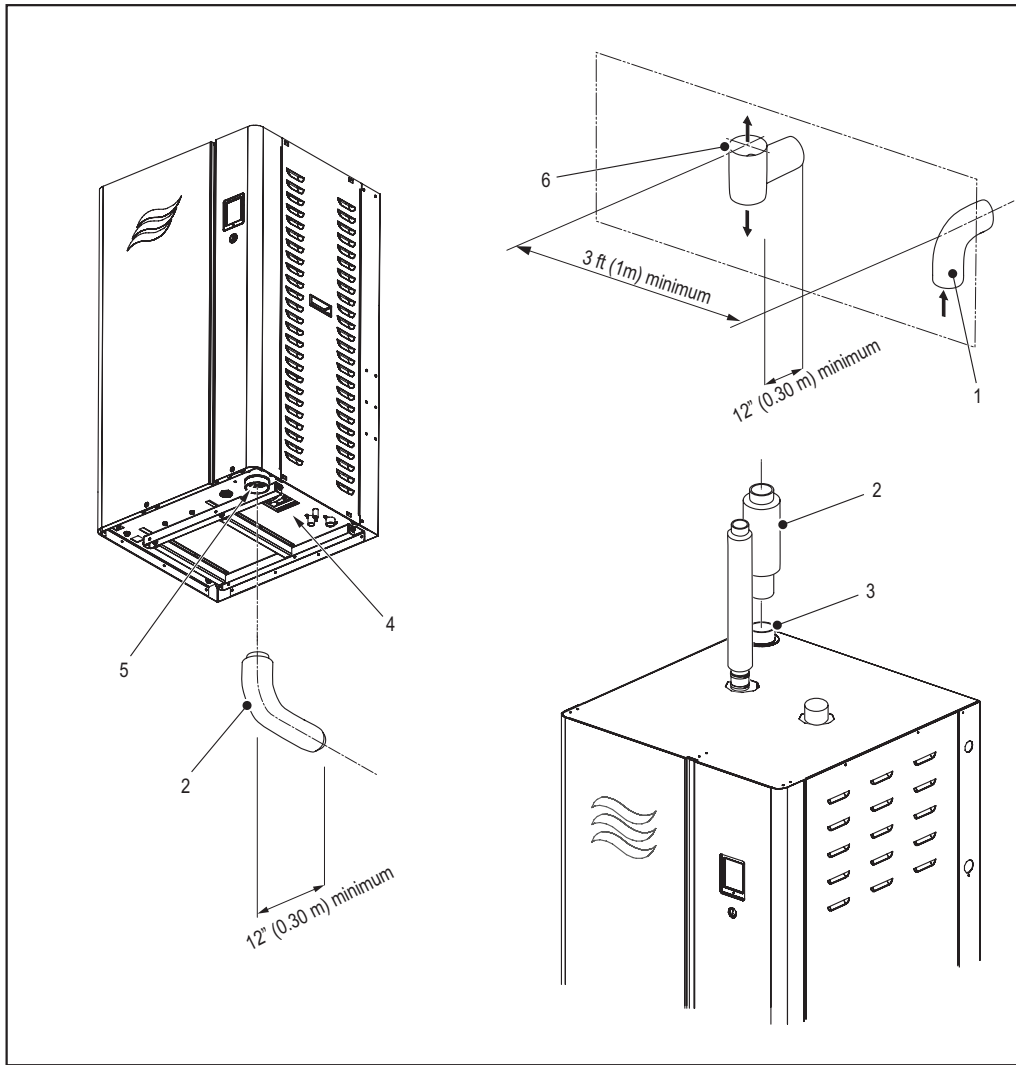

Figure 7: Nortec GS Humidifier Suggested Clearances

Table 9: Required Clearances*

Model	Overhead Clearance "A"	Right Side Clearance "B"	Ground Clearance "C"	Front Clearance "D"	Left Side Clearance "E"	Rear Clearance "F"
GS 50	16 in (406 mm)	24 in (610 mm)	24 in (610 mm)	36 in (914 mm)	0 in (0 mm)	0 in (0 mm)
GS 100	16 in (406 mm)	24 in (610 mm)	24 in (610 mm)	36 in (914 mm)	0 in (0 mm)	0 in (0 mm)
GS 150	16 in (406 mm)	24 in (610 mm)	0 in (0 mm)	36 in (914 mm)	0 in (0 mm)	0 in (0 mm)
GS 200	16 in (406 mm)	24 in (610 mm)	0 in (0 mm)	36 in (914 mm)	0 in (0 mm)	0 in (0 mm)
GS 300	16 in (406 mm)	24 in (610 mm)	0 in (0 mm)	36 in (914 mm)	0 in (0 mm)	0 in (0 mm)
GS 450	16 in (406 mm)	24 in (610 mm)	0 in (0 mm)	36 in (914 mm)	24 in (610 mm)	0 in (0 mm)
GS 600	16 in (406 mm)	24 in (610 mm)	0 in (0 mm)	36 in (914 mm)	24 in (610 mm)	0 in (0 mm)

* Consult local and national installation codes.

Table 10: Suggested Clearances (for ease of service and maintenance)

Model	Overhead Clearance "A"	Right Side Clearance "B"	Ground Clearance "C"	Front Clearance "D"	Left Side Clearance "E"	Rear Clearance "F"
GS 50	36 in (914 mm)	30 in (762 mm)	24 in (610 mm)	36 in (914 mm)	0 in (0 mm)	0 in (0 mm)
GS 100	36 in (914 mm)	30 in (762 mm)	24 in (610 mm)	36 in (914 mm)	0 in (0 mm)	0 in (0 mm)
GS 150	36 in (914 mm)	30 in (762 mm)	0 in (0 mm)	36 in (914 mm)	0 in (0 mm)	0 in (0 mm)
GS 200	36 in (914 mm)	30 in (762 mm)	0 in (0 mm)	36 in (914 mm)	0 in (0 mm)	0 in (0 mm)
GS 300	36 in (914 mm)	30 in (762 mm)	0 in (0 mm)	36 in (914 mm)	0 in (0 mm)	0 in (0 mm)
GS 450	36 in (914 mm)	30 in (762 mm)	0 in (0 mm)	36 in (914 mm)	30 in (762 mm)	0 in (0 mm)
GS 600	36 in (914 mm)	30 in (762 mm)	0 in (0 mm)	36 in (914 mm)	30 in (762 mm)	0 in (0 mm)

5.4.1.1 Overall Dimensions and Weight

The overall dimensions and weight of the Nortec GS humidifier are listed in [Table 11](#). **Note:** The dimensions and weights shown do not include the floor stand or wall mount bracket.

Table 11: Nortec GS Humidifier Overall Dimensions and Weights

Model	Dimensions			Weight	
	Height	Width	Depth	Net	Operating
GS 50-CS/NX	43.4 in (1102 mm)	23.5 in (598 mm)	21.2 in (539 mm)	190 lb (86.2 kg)	340 lb (154.2 kg)
GS 100-CS/NX	43.4 in (1102 mm)	23.5 in (598 mm)	21.2 in (539 mm)	210 lb (95.3 kg)	365 lb (165.6 kg)
GS 150-CS/NX	55.5 in (1410 mm)	27.0 in (684 mm)	27.7 in (705 mm)	320 lb (145.1 kg)	500 lb (226.8 kg)
GS 200-CS/NX	55.5 in (1410 mm)	37.8 in (960 mm)	27.7 in (705 mm)	480 lb (217.7 kg)	775 lb (351.5 kg)
GS 300-CS/NX	55.5 in (1410 mm)	37.8 in (960 mm)	27.7 in (705 mm)	480 lb (217.7 kg)	800 lb (362.8 kg)
GS 450-CS/NX	55.5 in (1410 mm)	62.2 in (1580 mm)	27.7 in (705 mm)	800 lb (362.9 kg)	1200 lb (544.3 kg)
GS 600-CS/NX	55.5 in (1410 mm)	73.2 in (1859 mm)	27.7 in (705 mm)	910 lb (412.8 kg)	1550 lb (703.1 kg)

5.4.2 Standard Wall Mounting – Compact Unit Only

Install the compact Nortec GS humidifier on the wall or other suitable vertical mounting surface as follows. Refer to [Figure 8 on page 30](#).

1. Check that the selected mounting location provides adequate clearances for maintenance, and is at an easily servicable height. Refer to ["Clearances" on page 26](#).
2. Make sure that the mounting surface has adequate structural strength to support the operating weight of the unit – refer to [Table 11 on page 28](#) for weights. Condaire recommends mounting to 3/4 (20 mm) thick plywood or equivalent.

3. Remove all the packaging material around the Nortec GS humidifier that was used for shipping the unit. Remove the accessory box and open its contents.
4. Assemble the mounting bracket using the instructions in the accessory box.
5. Locate the mounting bracket at the desired position on the wall or other suitable vertical mounting surface.
6. Attach the mounting bracket with one 3/8 in lag bolt and washer (not supplied). Use longer bolt if going through drywall or other structural material into the mounting surface.
7. Level the mounting bracket, and mark the locations of the remaining three attachment points.
8. Install three more 3/8 in lag bolts and washers (not supplied), and secure the mounting bracket to the mounting surface.
9. Remove the door panels from the humidifier.
10. Remove and discard the two shipping screws that secure the unit to the shipping pallet.



WARNING!

Heavy object – risk of personal injury, or damage to equipment!

Prevention: Use an appropriate lifting device to lift the humidifier. Lift the unit from the bottom, and not the side or top panels.

11. Carefully lift the humidifier by its base frame and raise it off the shipping pallet.
12. Carefully lower the humidifier onto the mounting bracket that is secured to the mounting surface.
13. Install four M6×12 bolts and washers (supplied) and secure the humidifier to the mounting bracket. Torque the bolts to 6.5 lb·ft (9 N·m).
14. Install the two L-brackets on the top of the unit with the sheetmetal screws (supplied).
15. Secure the L-brackets to the vertical mounting surface with two 1/4 in lag bolts and washers (not supplied).
16. Install the door panels.

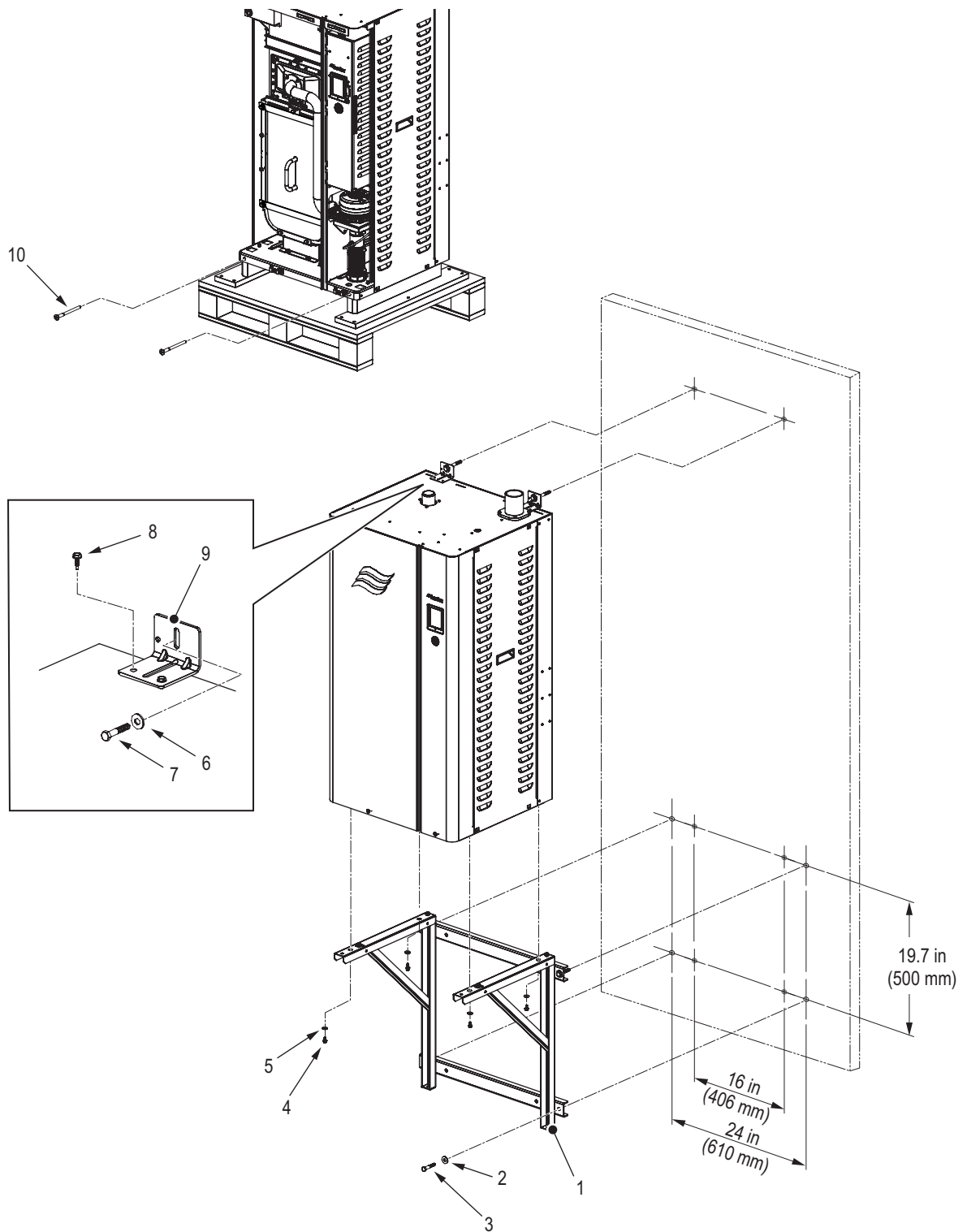

Figure 8: Standard Wall Mounting, Compact Unit Only

- 1 Bracket, mounting (supplied)
- 2 Washer, flat, 3/8 in (×4, not supplied)
- 3 Bolt, lag, 3/8×2 in (×4, not supplied)
- 4 Bolt, M6×12 (×4, supplied)
- 5 Washer, flat, M6 (×4, supplied)
- 6 Washer, flat, 1/4 in (×2, not supplied)
- 7 Bolt, lag, 1/4×1 in (×2, not supplied)
- 8 Screw, sheetmetal (×4, supplied)
- 9 Bracket, L (×2, supplied)
- 10 Screw, shipping (×2, discard)

5.4.3 Standard Floor Stand Mounting – Compact Unit Only

Install the compact Nortec GS humidifier on the floor stand, if desired, as follows. Refer to [Figure 9 on page 32](#).

1. Check that the selected mounting location provides adequate clearances for maintenance. Refer to [“Clearances” on page 26](#).
2. Remove all the packaging material around the Nortec GS humidifier that was used for shipping the unit. Remove the accessory box and open its contents.
3. Assemble the floor stand using the instructions in the accessory box.
4. Make sure that the floor is hard and level, then set the floor stand on the floor (and optionally against a wall or other suitable vertical mounting surface). Level the stand using the leveling screws on its feet.
Note: If desired, remove the leveling screws and secure the floor stand to the floor with 3/8 in bolts and washers (not supplied).
5. Remove the door panels from the humidifier.
6. Remove and discard the two shipping screws that secure the unit to the shipping pallet.



WARNING!

Heavy object – risk of personal injury, or damage to equipment!

Prevention: Use an appropriate lifting device to lift the humidifier. Lift the unit from the bottom, and not the side or top panels.

7. Carefully lift the humidifier by its base frame and raise it off the shipping pallet.
8. Carefully lower the humidifier onto the floor stand.
9. Install four M6×12 bolts and washers (supplied) and secure the humidifier to the floor stand. Torque the bolts to 6.5 lb·ft (9 N·m).
10. Install the two L-brackets on the top of the unit (optional) with the sheetmetal screws (supplied).
11. Secure the L-brackets to the vertical mounting surface with two 1/4 in lag bolts and washers (not supplied).
12. Install the door panels.

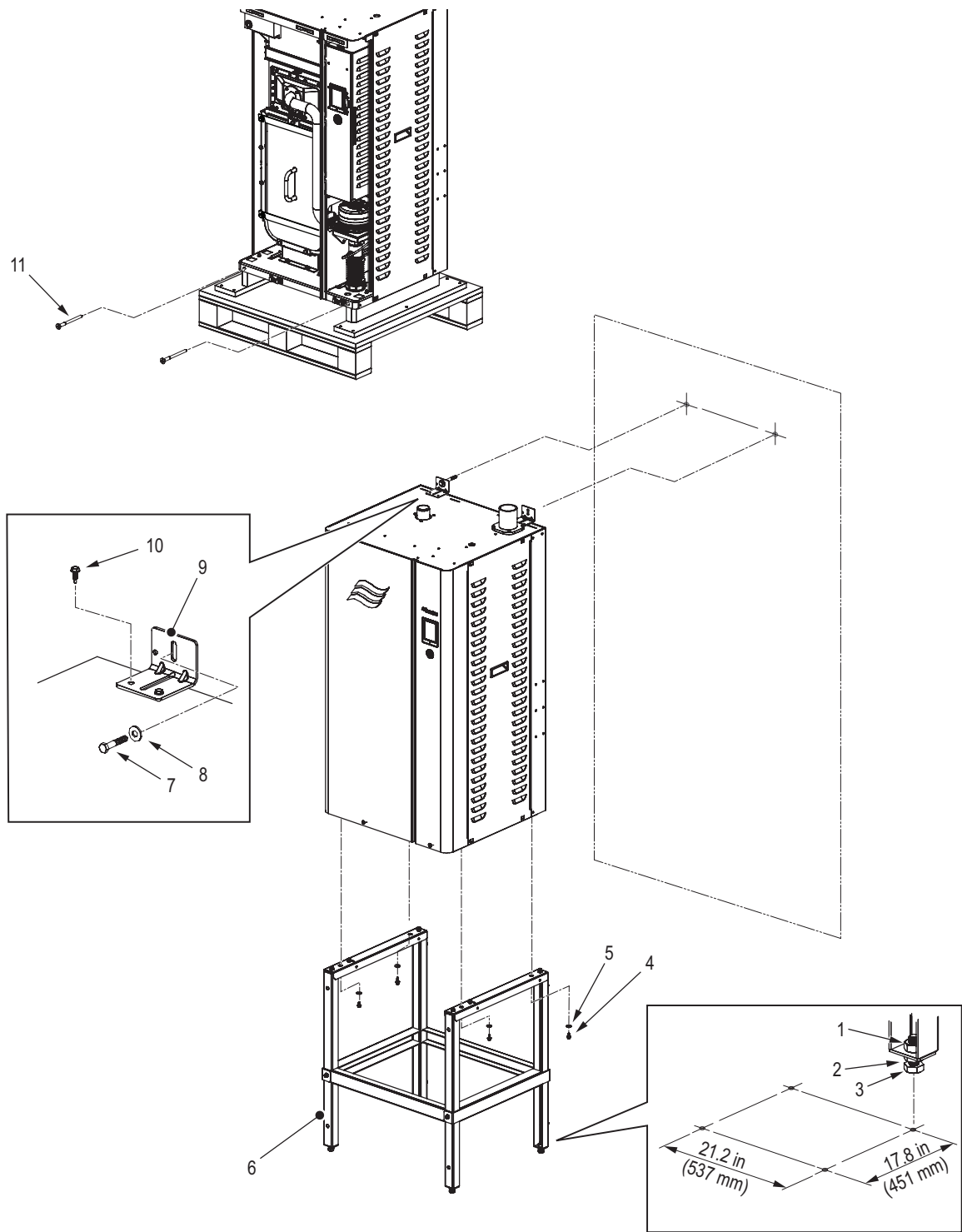

Figure 9: Standard Floor Stand Mounting, Compact Unit Only

- 1 Nut
- 2 Nut, jam
- 3 Screw, leveling
- 4 Bolt, M6×12 (×4, supplied)
- 5 Washer, flat, M6 (×4, supplied)
- 6 Stand, floor
- 7 Bolt, lag, 1/4×1 in (×2, not supplied)
- 8 Washer, flat, 1/4 in (×2, not supplied)
- 9 Bracket, L (×2, supplied – used if unit is installed against a vertical mounting surface)
- 10 Screw, sheetmetal (×4, supplied)
- 11 Screw, shipping (×2, discard)

5.4.4 Standard Mounting – Full-Size Unit

Install the full-size Nortec GS humidifier directly on the floor as follows. Refer to [Figure 10](#).

1. Check that the selected mounting location provides adequate clearances for maintenance. Refer to [“Clearances” on page 26](#).
2. Remove all the packaging material around the Nortec GS humidifier that was used for shipping the unit.



WARNING!

Heavy object – risk of personal injury, or damage to equipment!

Prevention: Use an appropriate lifting device to lift the humidifier. Lift the unit from the bottom, and not the side or top panels

3. Carefully lift the humidifier by its base frame and raise it off the shipping pallet. Lower it onto a hard level floor.
4. Add shims under the frame brackets, if necessary, to level the unit.

Note: If desired, secure the unit to the floor with 3/8 in bolts and washers (not supplied).

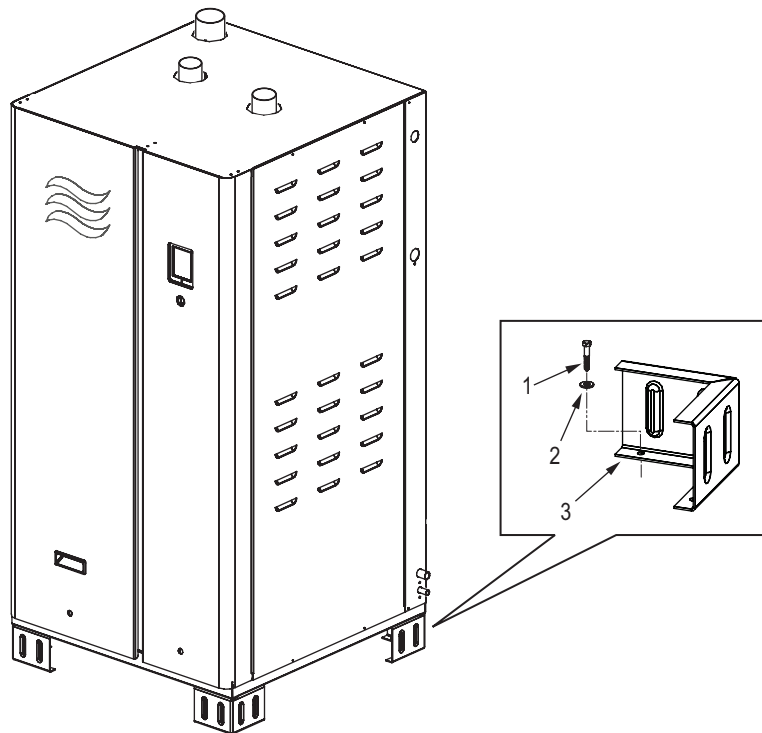

Figure 10: Standard Mounting, Full-Size Unit (GS 150 Shown)

- 1 Bolt, 3/8×2 in (×4, not supplied)
- 2 Washer, flat, 3/8 in (×4, not supplied)
- 3 Bracket, frame

5.4.5 Optional Stand Mounting – Full-Size Unit

Install the full-size Nortec GS humidifier on an optional mounting stand as follows. Refer to [Figure 11](#).

1. Check that the selected mounting location provides adequate clearances for maintenance. Refer to [“Clearances” on page 26](#).
2. Remove all the packaging material around the Nortec GS humidifier that was used for shipping the unit. Remove the accessory box and open its contents.
3. Assemble the mounting stand using the instructions in the accessory box.
4. Set the mounting stand on a hard level floor, and level it using shims, if necessary.

Note: If desired, secure the mounting stand to the floor with 3/8 in bolts and washers (not supplied).



WARNING!

Heavy object – risk of personal injury, or damage to equipment!

Prevention: Use an appropriate lifting device to lift the humidifier. Lift the unit from the bottom, and not the side or top panels

5. Carefully lift the humidifier by its base frame and raise it off the shipping pallet. Lower it onto the mounting stand. Check that it is seated properly.

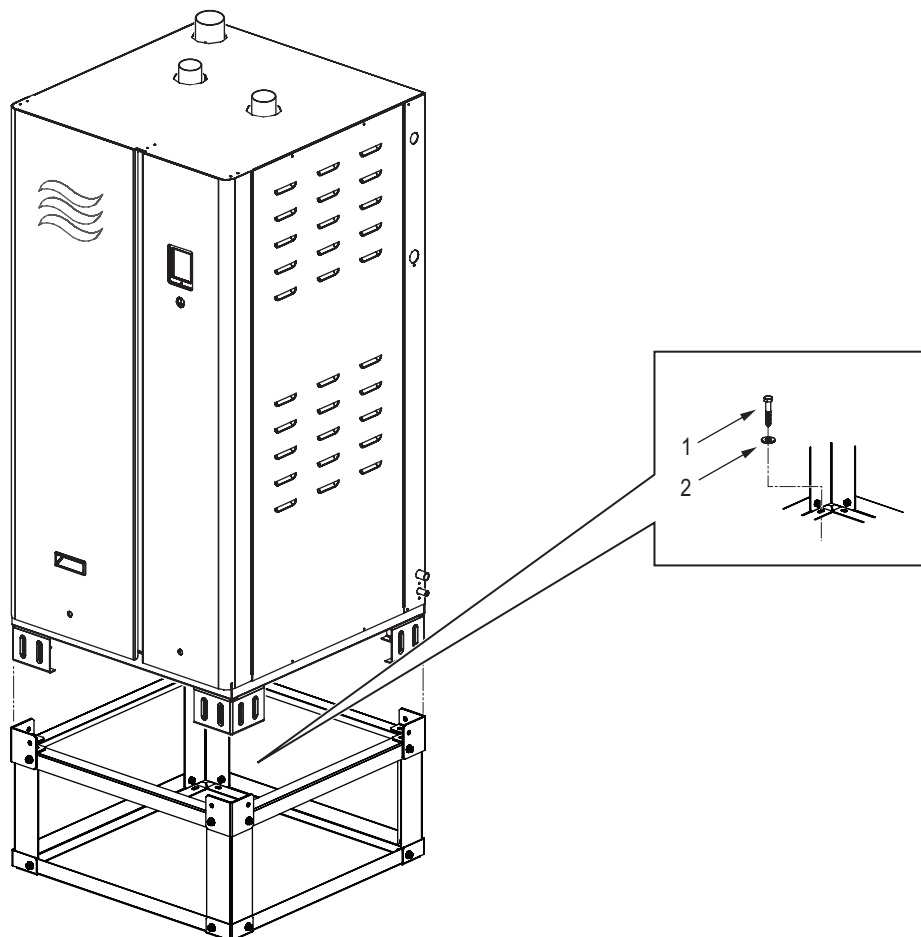

Figure 11: Optional Mounting, Full-Size Unit (GS 150 Shown)

- 1 Bolt, 3/8×2 in (×4, not supplied)
- 2 Washer, flat, 3/8 in (×4, not supplied)

5.4.6 Mounting Checklist

Check the following to ensure that the humidifier has been mounted correctly:

- Unit installed in the correct location (according to ["Clearances" on page 26](#))?
- Adequate clearance for servicing unit?
- Mounting surface stable, and capable of supporting the full operating weight of the humidifier?
- Unit level?
- Unit secured properly?

5.5 Steam Connection

Steam generated by the Nortec GS humidifier can be distributed into a conditioned space through an air handling unit (AHU) using Condairsteam distributors, blower packs or Condairsteam SAM-e steam distribution manifolds – refer to their respective manuals for installation details.

Refer to “[Site Requirements](#)” on page 24 for the steam and condensate line installation requirements. Read “[Best Practices for Installing Steam and Condensate Lines](#)” on page 37 before installing the main steam line and condensate lines.

5.5.1 Installing the Main Steam Pipe

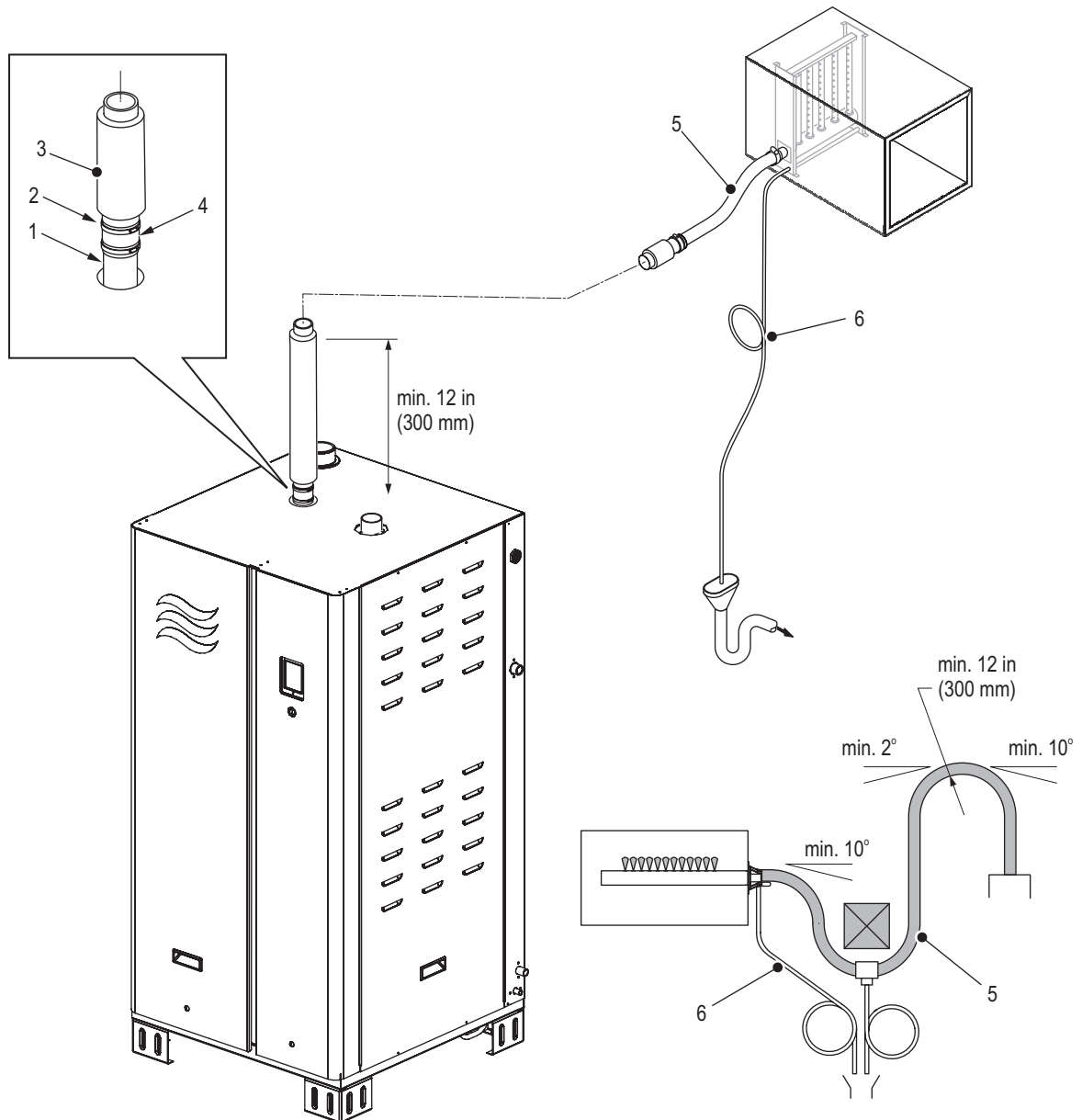

Figure 12: Main Steam Line Installation

- 1 Steam outlet, humidifier
- 2 Clamp, gear (supplied)
- 3 Steam pipe, rigid (main) – must rise straight up minimum 12 in (300 mm) above steam outlet before continuing to steam distributor. Refer to [Table 12 on page 37](#) for maximum equivalent length of steam line.
- 4 Cuff, hose (supplied)
- 5 Steam hose – must have minimum bend radius of 12 in (300 mm), and minimum upslope of 10° or minimum downslope of 2° to steam distributor. Steam hose must not sag – add condensate drain line, as shown, if necessary.
- 6 Drain line, condensate – must have minimum downslope of 1.2°. The trap should be minimum 12 in (300 mm) in diameter, and located minimum 12 in (300 mm) below the steam distributor or dip in the steam line.

5.5.2 Best Practices for Installing Steam and Condensate Lines

Condair recommends that you observe the following best practices for installing atmospheric steam lines and condensate lines.

Steam Line

- Use rigid steam pipe made of copper (MED Type-L) or stainless steel (minimum DIN 1.4301) exclusively. Steam pipes made of any other materials may adversely affect the operation of the unit, and will void the warranty.
- Refer to [Table 12](#) for the required minimum internal diameter of the steam pipe. The internal diameter of the steam pipe can be expanded, but once expanded a reduction in diameter is not permitted, except at the steam distributor.

Table 12: Steam Pipe Diameter

Model	Minimum Internal Diameter	Maximum Equivalent Steam Line Length
GS 50	1.75 in (45 mm)	45 ft (14 m)
GS 100	1.75 in (45 mm)	69 ft (21 m)
GS 150	3 in (76 mm)	100 ft (30 m)
GS 200	3 in (76 mm)	120 ft (37 m)
GS 300	3 in (76 mm)	150 ft (46 m)
GS 450	4 in (102 mm)	180 ft (55 m)
GS 600	4 in (102 mm)	260 ft (79 m)

- The length of the steam line should be kept as short as possible. It should not exceed the maximum equivalent length shown in [Table 12](#). Exceeding the maximum length can affect performance of the unit, and may void the warranty. Backpressure in the line combined with duct static pressure must not exceed 6 in H₂O (1.49 kPa) for compact units, and 10 in H₂O (2.49 kPa) for full-size units. Refer also to [Table 13 on page 38](#) for equivalent length of typical steam line fittings.

IMPORTANT! When calculating the backpressure on the unit, include allowance of approximately 0.12 in H₂O for every foot (100 Pa for every meter) of steam line, and every 90° elbow.

- Use long radius elbows for steam pipes. This minimizes backpressure and formation of condensation.

IMPORTANT! When determining the length and routing of steam lines, allowances must also be made for thermal expansion.

- The steam line from the humidifier must lead straight upwards for a minimum of 12 in (300 mm), before continuing on to the steam distribution system – refer to [Figure 12 on page 36](#). The steam line must have a minimum upslope of 10°, or a minimum downslope of 2° – refer to [Figure 13 on page 38](#).
- Use only Condair steam hose between the steam outlet on the humidifier and the steam distributor. Other types of steam hoses can affect performance of the unit, and may void the warranty. The length of the steam hose must be kept to a minimum. The minimum bend radius of the steam hose is 300 mm. The steam hose must not sag, and must have a minimum upslope of 10°, or a minimum downslope of 2° to the steam distributor.

IMPORTANT! When calculating the backpressure on the unit, include allowance of approximately 0.12 in H₂O for every foot (100 Pa for every meter) of steam line, and every 90° elbow. Allowances must also be made for shrinkage in the length of the steam hose due to aging.

- Use short lengths of steam hose to connect the steam line to the humidifier or steam distributor. Secure the steam hoses with gear clamps.



CAUTION!
Risk of damage to the gear clamp.

Do not over-tighten the gear clamp. The maximum torque value for gear clamps is 16 in·lbs (180 N·cm).

- Do not combine multiple steam lines, except at the steam distributor. Use a Condair adaptor specifically designed for that purpose, and only if the humidifiers connected to the adaptor operate in parallel.
- To minimize formation of condensation, the steam pipe must be insulated with a minimum of 1 in (25 mm) of pipe insulation over its entire length.
- The weight of the steam pipe must be supported so there is no load on the humidifier.



WARNING!
Risk of severe burns from contact with hot steam vapors!

Restrictions in the cross-section of the steam line will cause excessive backpressure in the steam tank when the unit is operating, which may cause unexpected release of hot steam vapors. Bare skin exposed to the hot steam vapors can result in severe burns. In addition, excess backpressure also affects performance of the unit.

Prevention: Observe the following:

- Upon completion of the installation, purge the steam line to remove any contaminants and installation materials.
- The steam hose (if used) must not have any kinks or other restrictions.
- To prevent condensate pockets, the steam line must not sag. If necessary, support the steam line with pipe clamps, trough, or wall brackets, and install a condensate drain at the lowest point in the steam line.
- DO NOT install a shutoff valve (e.g. a manually operated shutoff valve, solenoid valve, etc.) in the steam line.

Table 13: Equivalent Length of Typical Steam Line Fittings

Nominal Tube Size	Standard 90° Elbow	Standard 45° Elbow	Side-Outlet Tee
1.75 in (45 mm)	3.5 ft (1.1 m)	1.75 ft (0.5 m)	7 ft (2.1 m)
3 in (75 mm)	5 ft (1.5 m)	2.5 ft (0.8 m)	11 ft (3.4 m)
4 in (100 mm)	8 ft (2.4 m)	4 ft (1.2 m)	15 ft (4.6 m)

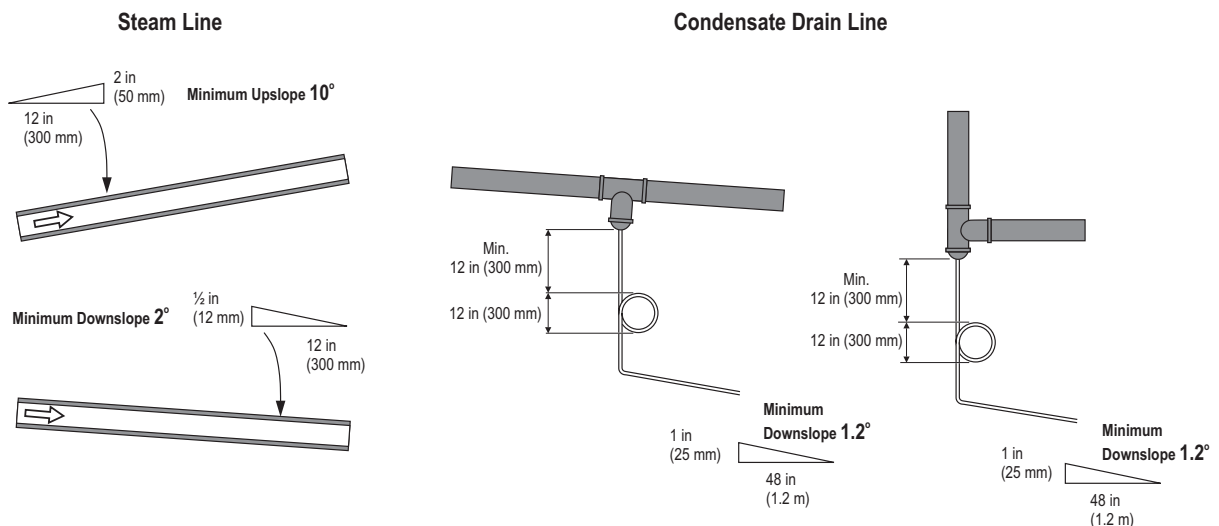

Figure 13: Steam and Condensate Line

Condensate Lines

- Use 1/2 in Condair condensate hose, or 1/2 in stainless steel pipe or copper pipe for condensate lines and traps.



WARNING!

Risk of severe burns from contact with hot fluids or steam!

The condensate lines may be filled with hot fluids or steam. Bare skin in contact with hot fluids or steam can result in severe burns.

Prevention: Never plumb the condensate lines to empty into a sink used by personnel. Always connect the lines to a floor drain according to applicable national and local plumbing codes.

- Condensate traps must also be installed at all low points and at horizontal-to-vertical transitions in the steam line. The condensate drain lines should always connect to full-size "Tee" connectors in the steam line. Refer to [Figure 13 on page 38](#).
- The condensate lines must have a minimum downslope of 1.2°, with a minimum 12 in (300 mm) diameter condensate trap, and connect to the building floor drain with condensate cooler (if required). The condensate trap must be at least 12 in (300 mm) below the condensate "Tee" and the steam distributor.
- For a steam line that is longer than 15 ft (4.5 m) up to the maximum recommended length, install condensate lines and traps at regular intervals. The maximum distance between condensate lines for long runs is 15 ft (4.5 m).
- Condensate lines must have individual traps before emptying to a common condensate drain. The common condensate drain must be sized appropriately to handle all the condensate.
- Make sure that the condensate lines allow proper flow.
- Do not over-tighten the hose clamps on the condensate lines.

IMPORTANT! Before starting up the unit, prime the condensate traps with water.

5.5.2.1 Common Steam and Condensate Line Installation Mistakes

Some common steam and condensate line installation mistakes are shown in [Figure 14](#).

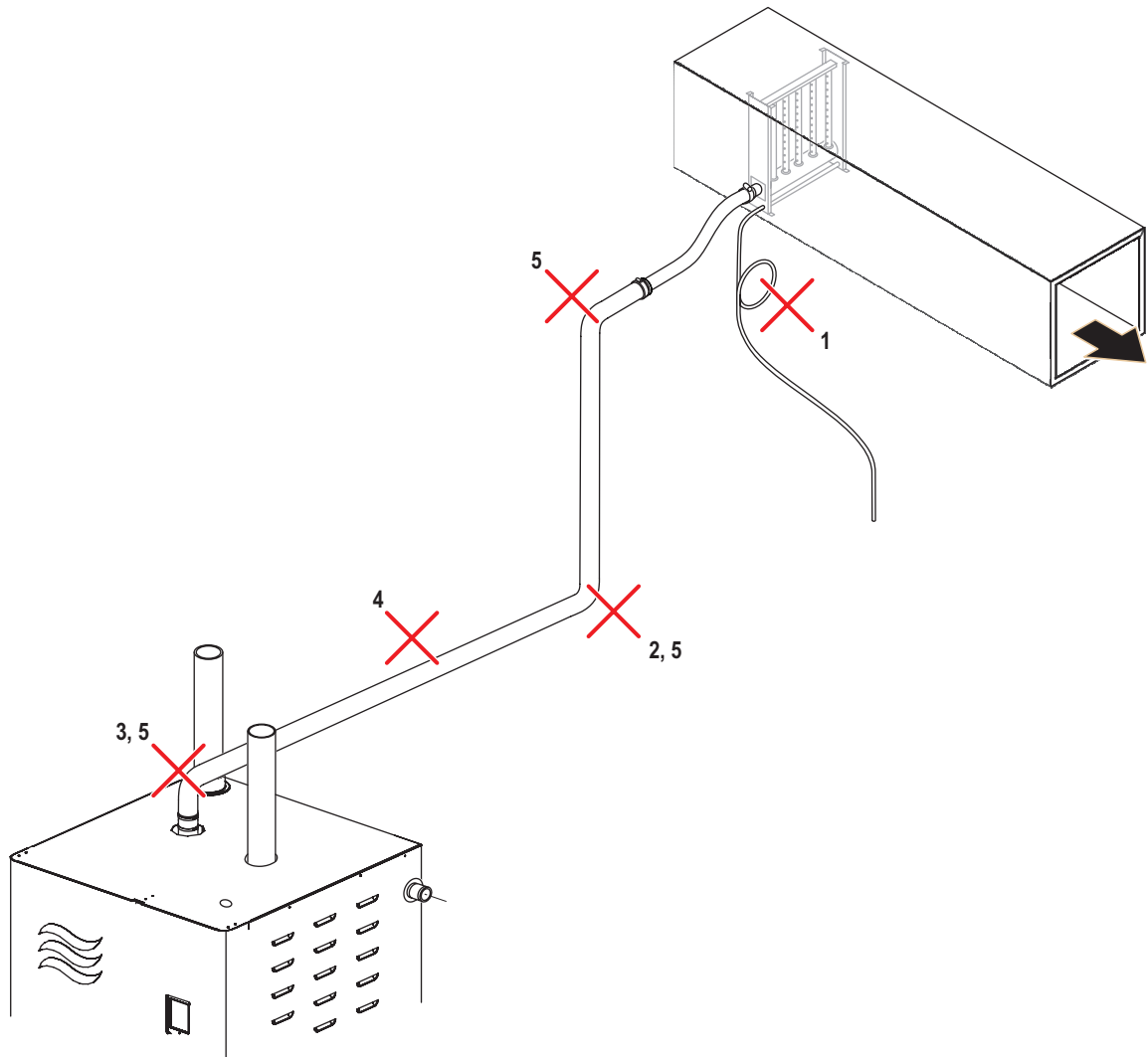

Figure 14: Common Steam and Condensate Line Installation Mistakes

- 1 The condensate trap is located less than the required minimum 12 in (300 mm) below the steam distributor.
- 2 No condensate trap is installed at the horizontal-to-vertical transition.
- 3 The steam line does not run straight up for the required minimum 12 in (300 mm) before continuing on to the steam distributor.
- 4 Steam line is not sloped – upslope minimum 10° /downslope minimum 2° is not maintained.
- 5 The required long radius elbow (for rigid pipe) is not used.

5.5.3 Steam Connection Checklist

Check the following to ensure that the steam connections for the humidifier have been installed correctly:

Steam Line

- Observed all best practices?
- Steam pipe sized correctly?
- The steam line does not exceed maximum equivalent length listed in [Table 12 on page 37?](#)
- Long radius elbows (for rigid pipes) used?
- Backpressure in the line combined with duct static pressure does not exceed 6 in H₂O (1.49 kPa) for compact units, or 10 in H₂O (2.49 kPa) for full-size units?
- Steam line runs straight up from the humidifier steam outlet for at least 12 in (300 mm) before bend?
- Steam line has minimum upslope of 10°, or minimum downslope of 2°?
- Steam line does not reduce in diameter except at the steam distributor; and condensate line installed just before the restriction?
- Steam lines do not merge except at the steam distributor through a Condair adaptor?
- Steam line does not sag?
- Steam connections secured with clamps? Clamps torqued adequately?
- Allowances made for thermal expansion of rigid pipes, and shrinkages of steam hose?
- Steam line insulated over its entire length?

Condensate Line

- Local regulations on drain water temperature requirements have been satisfied?
- Condensate traps installed at all low points, and at horizontal-to-vertical transitions in the steam line?
- Condensate lines in the steam line always connect to full-size "Tee" connectors?
- Condensate traps have a minimum loop diameter of 12 in (300 mm) and installed at least 12 in (300 mm) below the condensate "Tee" and the steam distributor?
- All condensate lines have a minimum downslope of 1.2°?
- Condensate traps installed at regular intervals on long runs exceeding 15 ft (4.5 m)?
- Condensate lines have individual traps before emptying to a common condensate drain? Condensate drain sized appropriately to handle all the condensate?
- Condensate traps primed with water?

5.6 Water Connections

Refer to “[Site Requirements](#)” on page 24 for the water supply and drain requirements.

Read “[Water Connection Requirements](#)” on page 45, and perform the water connections as shown in [Figure 15](#) or [Figure 16](#) on page 43, as applicable.

5.6.1 Water Connections – Compact Unit

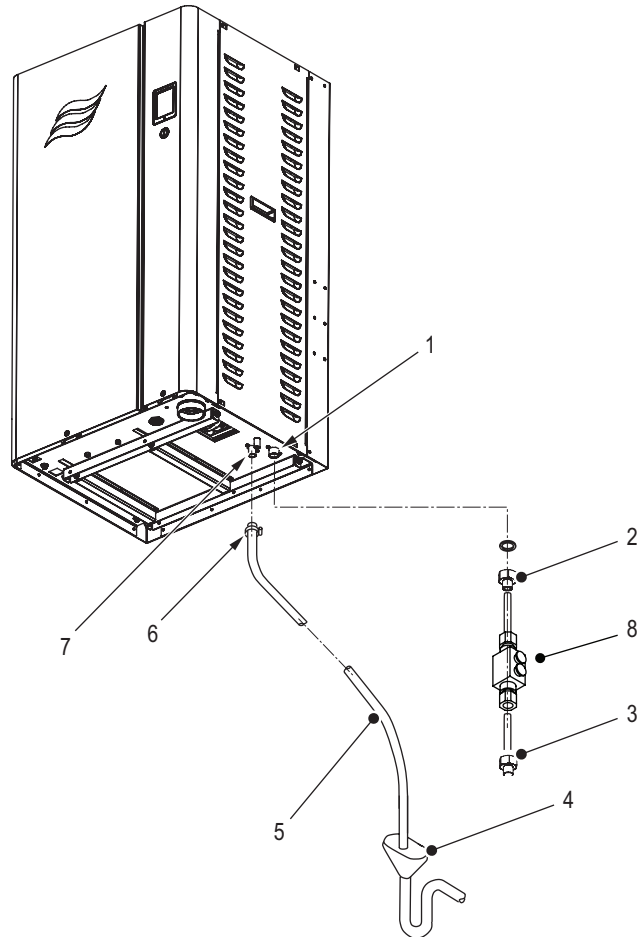

Figure 15: Water Supply and Drain Connections, Compact Unit

- 1 Inlet, fill valve – 3/4 in BSPP (plastic thread)
- 2 Adaptor, 3/4 in BSPP to 1/2 in NPT (supplied)
- 3 Supply line, water – minimum 1/2 in (13 mm) diameter
- 4 Funnel, air gap – should be minimum 2-1/2 in (64 mm) in diameter, and drain pipe connected to it should have minimum diameter of 1-1/2 in (38 mm). Must be located within 3 ft (1 m) from the unit (or according to code)
- 5 Hose, drain, 7/8 in (22 mm) I.D. (not supplied) – minimum downslope of 1.2°, and must not touch sides or bottom of funnel
- 6 Clamp, hose (not supplied)
- 7 Outlet, drain, 7/8 in (22 mm) O.D. (unthreaded)
- 8 Double check valve backflow preventer (supplied by others)

5.6.2 Water Connections – Full-Size Unit

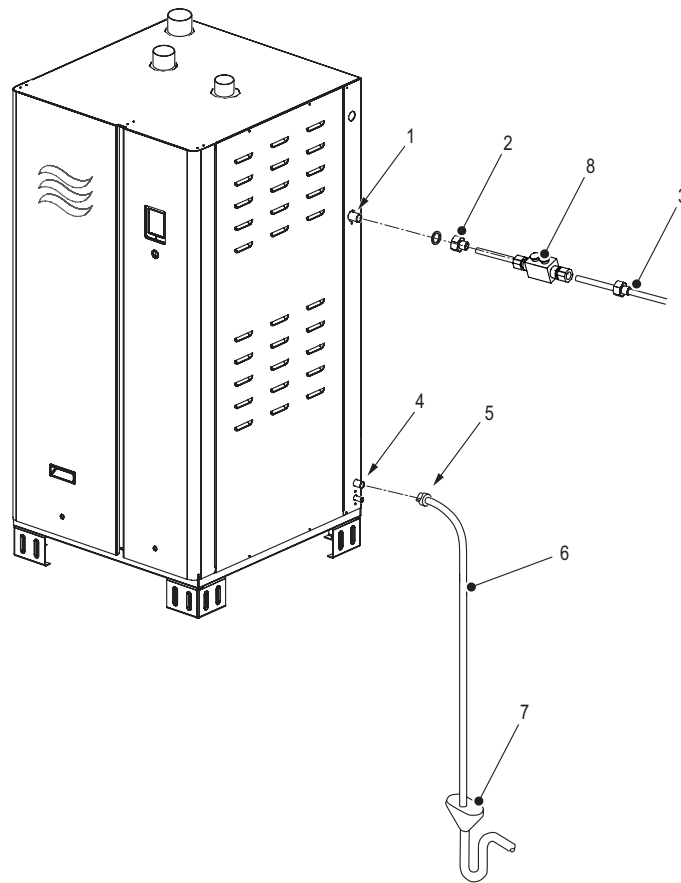

Figure 16: Water Supply and Drain Connections, Full-Size Unit

- 1 Inlet, fill valve – 3/4 in BSPP (plastic thread)
- 2 Adaptor, 3/4 in BSPP to 1/2 in NPT (supplied)
- 3 Supply line, water – minimum 1/2 in (13 mm) diameter
- 4 Outlet, drain, 7/8 in (22 mm) O.D. (unthreaded)
- 5 Clamp, hose (not supplied)
- 6 Hose, drain, 7/8 in (22 mm) I.D. (not supplied) – minimum downslope of 1.2°, and must not touch sides or bottom of funnel
- 7 Funnel, air gap – should be minimum 2-1/2 in (64 mm) in diameter, and drain pipe connected to it should have minimum diameter of 1-1/2 in (38 mm). Must be located within 3 ft (1 m) of the unit (or according to code).
- 8 Double check valve backflow preventer (supplied by other)

5.6.3 Installing Exhaust Condensate Drain Line (CS/NX Model Only)

Install the exhaust condensate drain line (CS/NX model only) as shown in [Figure 17](#).

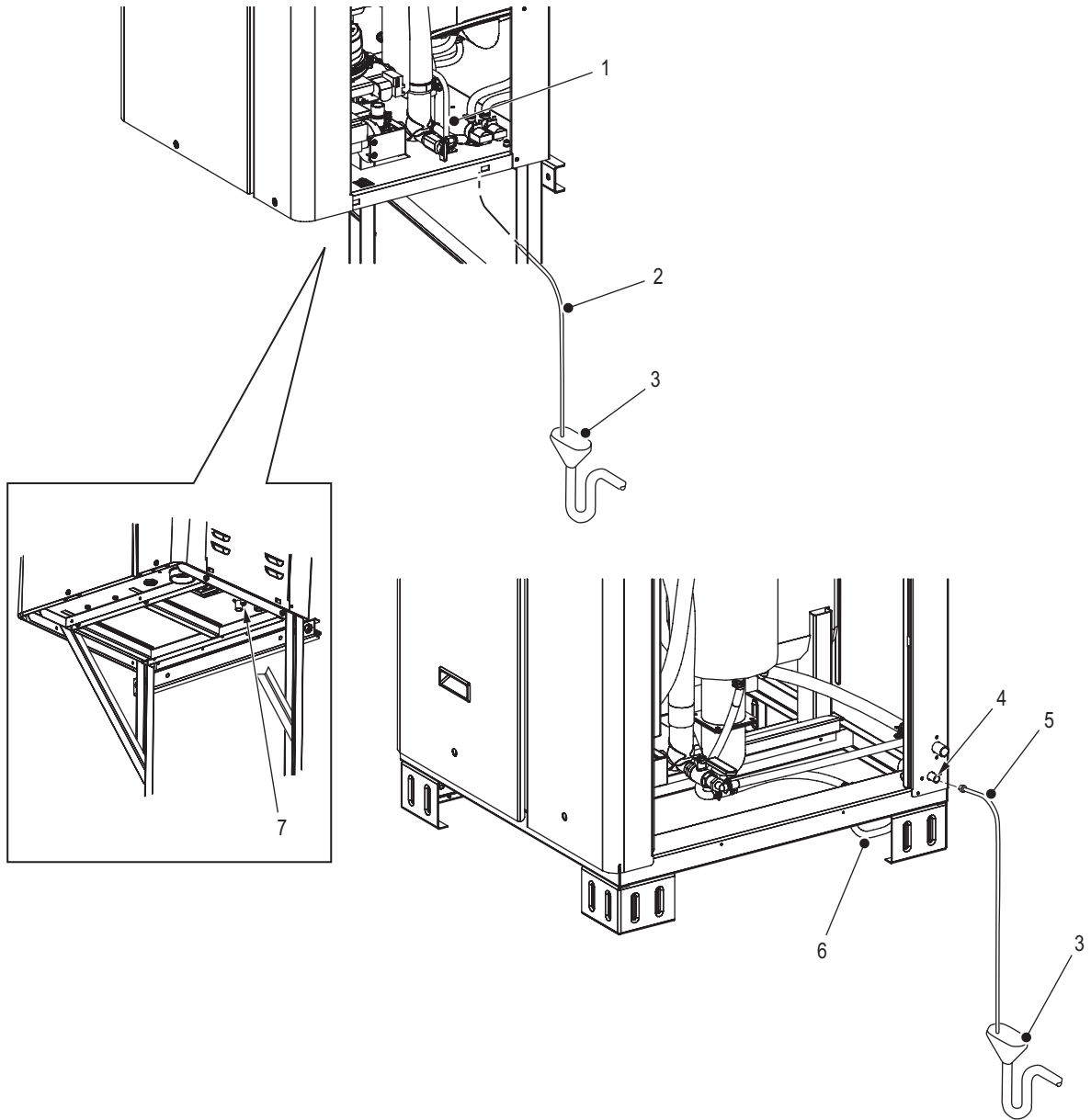

Figure 17: Exhaust Condensate Drain Line (CS/NX Model Only)

- 1 Trap, internal condensate (compact unit) – primed with water
- 2 Hose, drain, exhaust condensate (compact unit) – (not supplied) must have minimum downslope of 1.2°, and must not touch sides or bottom of funnel. Use Condair condensate hose.
- 3 Funnel, air gap – funnel must be located below the condensate outlet and within 3 ft (1 m) of the unit (or according to code)
- 4 Outlet, condensate drain (full-size unit), 1/2 in (13 mm) O.D. (unthreaded)
- 5 Hose, drain, exhaust condensate (full-size unit) – (not supplied) must have minimum downslope of 1.2°, and must not touch sides or bottom of funnel.
- 6 Trap, internal condensate (full-size unit) – primed with water
- 7 Outlet, condensate drain (compact unit), 3/8 in (9.5 mm) O.D. (unthreaded)

5.6.4 Water Connection Requirements

Water and drain connections must meet the following requirements:

- All water supply and drain connections must be installed to local plumbing codes.
- For ease of maintenance, a water shutoff valve and union fitting must be installed in the supply line before the humidifier.
- If a water filter is used (optional, but recommended), it must be installed as close as possible to the humidifier.
- Prevent water from the tank from re-entering the water supply. Install a double check valve back-flow preventer and secure it along the water supply line to the unit. Adhere to all local and national installation regulations.
- The water supply piping to the humidifier should be minimum 1/2 in (13 mm) in diameter with a 1/2 in NPT female end. The water supply pipe can be made of plastic (pressure-proof to 100 psig (690 kPa) and certified for use with drinking water systems), copper (not permitted for DI water) or stainless steel (minimum DIN 1.4301).



CAUTION!

Risk of damage to the plastic threads in the fill valve!

Prevention: Hand-tighten the NPT adaptor to the fill valve.

- The air gap funnel in the floor should be located away (max 3 ft (1 m) from the unit) from the control cabinet to keep any rising steam from damaging the electrical components in the control cabinet. The diameter of the air gap funnel should be minimum 2-1/2 in (64 mm).
- The drain pipe connecting the air gap funnel to the building drain should have a minimum inner diameter of 1-1/2 in (38 mm). Use stainless steel (minimum DIN 1.4301) or copper pipe (not permitted for DI water).
- The drain hose from the humidifier should be as short as possible, and empty into the air gap funnel without touching its sides or bottom. Drain hose must have a minimum constant downslope of 1.2° and must be secured with a hose clamp. The drain hose must be rated for 212 °F (100 °C).
- Install the condensate drain hose (CS/NX model only), and secure it with a hose clamp – refer to [Figure 17 on page 44](#). The hose must be rated to 212 °F (100 °C). Connect the hose to a condensate neutralization device, if required by local code, before connecting the hose to a drain.
- Upon completion of installation, disconnect and flush the water supply and drain lines to clear out any debris in the lines. Check the strainer in the fill valve is free of all debris. Reconnect the lines.
- Prime the condensate trap inside the unit (CS/NX model only) with water.
- **Drain water cooling reduces the drain water exiting the unit to 140 °F (60 °C).**

5.6.5 Water Connections Checklist

Check the following to ensure that the water connections for the humidifier have been installed correctly:

- Water quality meet the requirements listed in [Table 6 on page 24](#)?
- Shutoff valve and union fitting installed in supply line?
- Double check valve backflow preventer is installed along the water supply line to the unit? Is the double check valve backflow preventer installed, adhering to all applicable local and national installation regulations?
- Water supply piping to humidifier minimum 1/2 in (13 mm) diameter? Plastic pipe (pressure-proof and certified for use with drinking water systems), copper or stainless steel if using potable drinking water or RO water? Plastic or stainless steel pipe if using DI water?
- 5 µm water filter (optional, but recommended) installed in the supply line close to the humidifier?
- Water supply temperature 34-60 °F (1-15 °C)? Do not exceed 77 °F (25 °C).
- Water supply surge-protected and pressure regulated to 30-80 psig (207-550 kPa)?
- Check for leaks in the water supply line?
- Air gap funnel in the floor located away (max 3 ft (1 m) from the unit) from the control cabinet in the humidifier?
- Air gap funnel minimum 2-1/2 in (64 mm) in diameter?
- Drain pipe between air gap funnel and building drain have a minimum internal diameter of 1-1/2 in (38 mm)? Copper or stainless steel pipe if using potable drinking water or RO water? Stainless steel pipe if using DI water?
- Drain hose from humidifier empty into the air gap funnel without touching its sides or bottom? Drain hose have a minimum constant downslope of 1.2°, and secured with hose clamp? Drain hose rated for 212 °F (100 °C)?
- Condensate hose installed (CS/NX model only)? Hose rated for 212 °F (100 °C)?
- Condensate trap inside unit primed with water?
- Water supply line and drain lines flushed? Strainer in the fill valve free of debris?

5.7 Combustion Air Connection

Combustion air provisioning must meet the requirements stated in Sections 5.3 of the National Fuel Gas Code (ANSI Z223.1) in the USA, or Sections 7.2, 7.3, 7.4 of the CAN/CGA B149 Installation Codes in Canada, or applicable provisions of the local building codes.

Excess exposure to contaminated combustion air will result in safety and performance-related problems with the humidifier. Known contaminants include: halogens, ammonia, and chlorides, excessive dust, lime or dirt. Excess exposure to these contaminants will also affect the on-board electronics. Contact Condaire if you have any questions. If necessary, isolate the unit from the contaminated space.

Refer to “[Site Requirements](#)” on page 24 for combustion air requirements.

Select the type of installation required for combustion air – refer to “[Space Air Installation](#)” or “[Sealed Combustion Installation](#)”, as applicable.

5.7.1 Space Air Installation

This type of installation draws combustion air from inside the room/space where the humidifier is installed. Refer to [Table 14](#) for the required minimum cross-sectional area for the fresh air intake in the room/space. An appropriate opening to the outside of the building must be provided to allow fresh combustion air into the space. Adhere to all local and national installation regulations.

Note: Condaire requires installing an elbow (fitted with a screen) at the intake air inlet on all Nortec GS 150-600 units to prevent dirt and debris from being drawn into the combustion chamber. Seal the connection with silicone sealant. Keep the area around the air intake clear of all obstructions. Refer to [Figure 18](#). Refer to [Table 15 on page 48](#) for outside diameter of elbow.

Table 14: Room Fresh Air Intake Cross-sectional Area

Model	Minimum Cross-sectional Area
GS 50	8 in ² (51.61 cm ²)
GS 100	13 in ² (83.87 cm ²)
GS 150	18 in ² (116.13 cm ²)
GS 200	23 in ² (148.39 cm ²)
GS 300	35 in ² (225.81 cm ²)
GS 450	53 in ² (341.93 cm ²)
GS 600	71 in ² (458.06 cm ²)

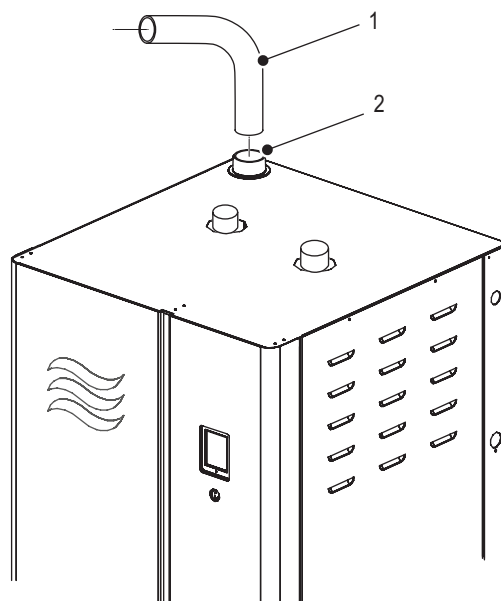

Figure 18: Space Air Installation – GS 150-600

- 1 Elbow (not supplied)
- 2 Inlet, intake air (full-size unit)

5.7.2 Sealed Combustion Installation

A sealed combustion installation draws fresh combustion air from the outside. Sealed combustion requirements for combustion air are governed by national and local installation codes, as stated at the beginning of this section. The vent diameter listed in [Table 15](#) must be maintained over the entire length of the vent. Adhere to all local and national installation codes.

In addition, refer to [“Sealed Combustion Installation Requirements” on page 49](#).

Table 15: Air Intake Vent Diameter

Model	Intake Vent Diameter
GS 50	2 in (50 mm)
GS 100 GS 150	3 in (75 mm)
GS 200 GS 300	4 in (100 mm)
GS 450 GS 600	6 in (150 mm)

[Figure 19](#) shows the sealed combustion connection for the compact and full-size Nortec GS humidifiers.

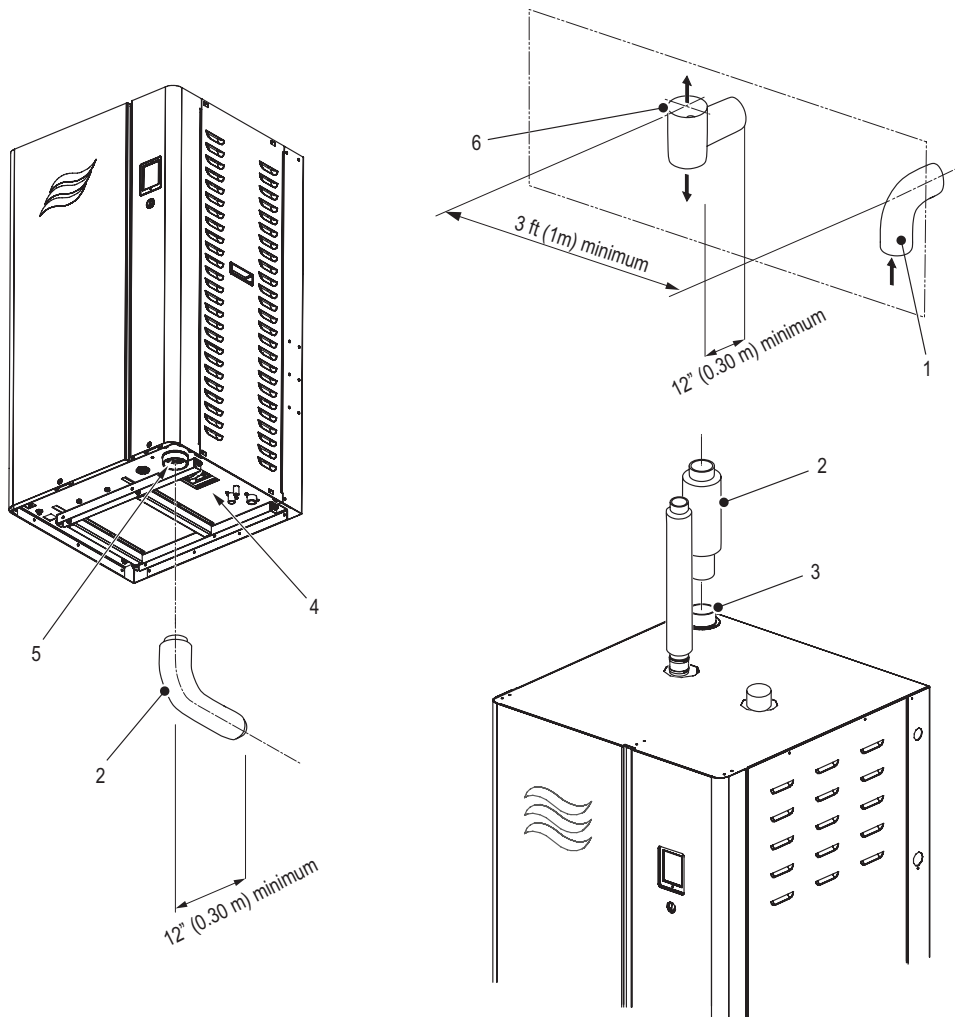

Figure 19: Nortec GS Series Sealed Combustion Connection

- 1 Terminal, air intake (elbow) – terminal located outside building and facing down (not supplied), 12 " (30cm) from wall.
- 2 Vent, intake – wrapped with insulation (not supplied)
- 3 Inlet, intake air (full-size unit)
- 4 Access, maintenance (compact unit) – do not block
- 5 Inlet, intake air (compact unit)
- 6 Terminal, exhaust ("Tee") – terminal located outside building and opening vertical (not supplied), 12" (30cm) from wall.

Sealed Combustion Installation Requirements

In addition to the requirements of the applicable national and local codes for sealed combustion installations, the following requirements must also be satisfied:

- The intake vent must not exceed an equivalent length of 100 ft (30 m), except for the Nortec GS 50 using propane gas which is limited to 50 ft (15 m).
Note: Each 90° bend is equal to 10 ft (3 m) of straight pipe, and each 45° bend is equal to 5 ft (1.5 m) of straight pipe. The intake vent should not have more than six bends.
- The intake vent diameter is listed in [Table 15 on page 48](#). The vent diameter must remain uniform over the entire run.
- Intake vent pipes can be made of stainless steel, ABS, PVC, CPVC or poly-propylene. All joints and seams must be sealed with an appropriate sealant.

IMPORTANT! Route the intake vent so that it does not obstruct access to any of the services to the humidifier. On the compact unit, make sure that the maintenance access for the drain pump is not obstructed.

- The intake vent must be supported every 5 ft (1.5 m), and at every pipe bend.
- An intake (elbow) terminal must be installed on the outside termination of the air intake vent, with the elbow facing down – refer to [Figure 19 on page 48](#). The location and spacing between the air intake terminal and exhaust vent terminal must comply with all local and national regulations, with at least a minimum spacing of 3 ft (1 m) between them.
- At low temperatures, water condensation can occur on the outside of the air intake vent. To prevent this, Condaire suggests adding in-line heating and insulation on the intake vent.

5.7.3 Combustion Air Checklist

Check the following to ensure that the combustion air connection for the humidifier has been installed correctly:

- Combustion air requirements for the specific type of installation selected meet all national and local regulations?

Space Air Installation

- Fresh combustion air requirements for the room/space ([Table 14 on page 47](#) and all national and local regulations) satisfied?
- Elbow installed at the intake air inlet (on Nortec GS 150-600 units)?

Sealed Combustion Installation

- All relevant national and local regulations for sealed combustion installation satisfied?
- Intake vent length does not exceed an equivalent length of 100 ft (30 m)? If unit is a Nortec GS 50 using propane gas, is it limited to 50 ft (15 m)? Maximum six bends?
- Vent diameter as listed in [Table 15 on page 48](#), and uniform over the entire run?
- All joints and seams sealed with appropriate sealant?
- Intake vent supported?
- Spacing between air intake terminal and exhaust vent terminal minimum 3 ft (1 m)?
- Intake vent heated and insulated in cold climates?

5.8 Exhaust Vent Connection

The Nortec GS CS/NX model uses a condensing type exhaust venting system, and must be installed as a Category IV appliance.

The general requirements and the different exhaust venting types are discussed in [“General Requirements”](#). Other specific requirements are listed in [“Exhaust Vent Installation for CS/NX Model” on page 55](#).

5.8.1 General Requirements

The exhaust vent system used with the Nortec GS series humidifier must satisfy the following general requirements:

- The exhaust vent systems shall be certified to UL or UL/CSA standard, and meet the installation requirements in Part 7 (Venting of Equipment) of the National Fuel Gas Code (ANSI Z223.1) in the USA, or Section 7 (Venting Systems and Air Supply for Appliances) of the CAN/CGAB149 Installation Codes in Canada, or applicable provisions of the local building codes. Any local regulations related to exhaust venting systems must also be adhered to.
- In applying the codes, refer to the vent system manufacturer's instructions, the local gas supplier regulations, and the specific instructions in this manual.
- This appliance must be installed in compliance with national regulations and codes. The installation must only be performed by a qualified technician who is well versed with these codes and the local requirements of the jurisdiction.
- Proper removal of combustion gases must be assured, and building materials must be protected from degradation by flue gases.
- Never mix venting types. Never use two different manufacturer's equipment for the same exhaust vent.
- All horizontal exhaust vent runs must maintain a constant minimum upslope of 2° to prevent accumulation of condensate.
- When an exhaust vent run exceeds 20 ft (6.1 m), insulate the exhaust vent pipe to reduce the amount of condensate that could form in the flue gases.
- When an exhaust vent passes through a cold area or a location that has large amounts of air flow over the vent, insulate the exhaust vent pipe to prevent condensation inside the vent.
- When an exhaust vent passes through walls, floors, and ceilings, proper clearances must be maintained around combustible materials and venting manufacturer's fire stop equipment.
- The exhaust vent shall not pass through any air circulation duct or plenum.



WARNING!

Risk of severe burns from contact with hot exhaust vent!

Prevention: Install a screen or barrier around the exhaust vent to prevent contact with it.

- Exhaust condensate management is required on all Nortec GS (CS and NX models) installations. Refer to [“Exhaust Vent Installation for CS/NX Model” on page 55](#).

IMPORTANT! Before starting up the unit, prime all condensate traps with water.

- Never vent into an un-lined masonry or concrete chimney unless the chimney is sized and installed according to the provisions of the national fuel code in the USA (ANSI Z223.1) or the Canadian standards (CSA B149).
- A chimney or exhaust vent should extend at least 3 ft (1 m) above the roof, and at least 2 ft (0.6 m) above any ridge within 10 ft (3 m) of the chimney. Local codes apply.

- The exhaust vent must terminate at a sufficient height above the roof to prevent blockage due to accumulation of snow.
 - The exhaust vent must be secured with hangers or pipe straps. All horizontal runs must be adequately supported with hangers or straps to prevent sagging.
 - The exhaust vent must not exceed an equivalent length of 100 ft (30 m), except for the Nortec GS 50 using propane gas which is limited to 50 ft (15 m).
 - The vent run should be as direct as possible with no more than six elbows in the system.
- Note:** Each 90° elbow is equivalent to 10 ft (3 m), and each 45° elbow is equivalent to 5 ft (1.5 m) of straight pipe.
- [Table 16](#) lists the diameter of the exhaust vent. The vent diameter must remain uniform over the entire run. Adhere to all local and national installation codes.

Table 16: Exhaust Vent Details

Model	Appliance Category	Exhaust Outlet Size	Exhaust Vent Diameter	Vent Type
GS 50-CS/NX	Category IV	(60 mm)*	2 in	CPVC only
GS 100-CS/NX	Category IV	(80 mm)*	3 in	Type BH (stainless steel) or CPVC
GS 150-CS/NX	Category IV	(80 mm)*	3 in	Type BH (stainless steel) or CPVC
GS 200-CS/NX	Category IV	(100 mm)*	4 in	Type BH (stainless steel) or CPVC
GS 300-CS/NX	Category IV	(100 mm)*	4 in	Type BH (stainless steel) or CPVC
GS 450-CS/NX	Category IV	(150 mm)*	6 in	Type BH (stainless steel) or CPVC
GS 600-CS/NX	Category IV	(150 mm)*	6 in	Type BH (stainless steel) or CPVC

* The exhaust outlet on the CS/NX unit has a female connection (metric size). Each unit is supplied with a metric to imperial adaptor (with internal seals) to accommodate imperial vent sizes.

Sidewall Venting Requirements

The following additional requirements of the National Fuel Gas Code (ANSI Z223.1), or CAN/CGA B149 Installation Codes must be satisfied if the exhaust vent terminates through a sidewall:

- Locate the humidifier as close as possible to the wall that is used for termination of the vent.
- Locate the exhaust terminal at least 3 ft (900 mm) above any forced air inlet located within 10 ft (3 m); or at least 4 ft (1.2 m) below, and 4 ft (1.2 m) horizontally from, or 12 in (300 mm) above any door, window, or gravity air inlet into any building.
- Maintain a minimum horizontal clearance of 4 ft (1.2 m) from electric meters, gas meters, regulator and relief equipment.
- Install certified vent terminals at the vent terminations.
- Locate the vent terminal at least 7 ft (2.1 m) above grade when it is adjacent to public walkways.
- Locate the bottom of the vent terminal at least 12 in (300 mm) above grade or ground, or normally expected snow accumulation level. The snow level may be higher on walls exposed to prevailing winds.
- Avoid areas where experience shows that condensate drip may cause problems – such as above planters, patios, or over public walkways, or over an area where condensate or vapor could create a nuisance or hazard, or could be detrimental to the operation of regulators, relief valves, or other equipment. Refer to the vent manufacturer's installation instructions.
- The vent terminal must be installed in the same atmospheric pressure zone as the combustion air inlet for the humidifier. If that is not possible (as in cases of positive or negative room pressures), sealed combustion must be utilized.

Figure 20 on page 53 and Figure 21 on page 54 show the general types of venting arrangements. These are guidelines only. For the specific venting arrangements refer to “Exhaust Vent Installation for CS/NX Model” on page 55. Adhere to all national or local codes.

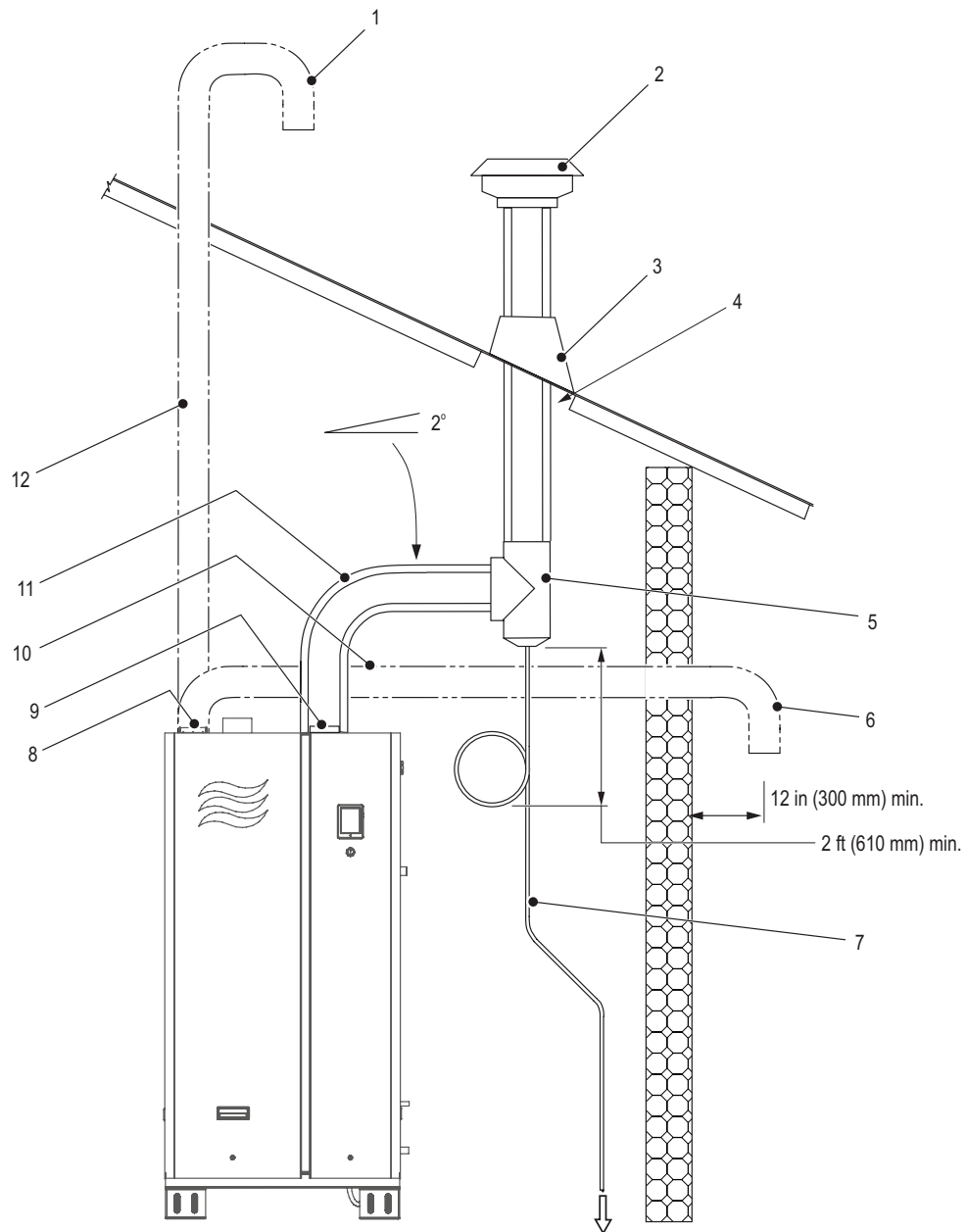

Figure 20: Vertical Venting (with Optional Sealed Combustion Hookup) – Category IV

- 1 Terminal, air intake – elbow pointed down (for optional sealed combustion vertical hookup)
- 2 Cap, vent, exhaust – UL/CSA-listed
- 3 Flashing
- 4 Air gap – must be maintained to local codes
- 5 "Tee", condensate
- 6 Terminal, air intake – 90° elbow pointed down, for optional sealed combustion hookup outside
- 7 Drain, condensate (with trap) – minimum 12 in (300 mm) trap height, and connected to floor drain or condensate pump
- 8 Inlet, air intake
- 9 Outlet, exhaust
- 10 Vent, air intake – for optional sealed combustion horizontal hookup
- 11 Vent, exhaust, type BH – refer to [Table 16 on page 51](#) for vent details. All joints air and water-tight. Short horizontal run with slope as shown (recommended, but not required). All horizontal-to-vertical transitions must include a full condensate "Tee" with condensate

- port and trap.
 12 Vent, air intake – for optional sealed combustion vertical hookup

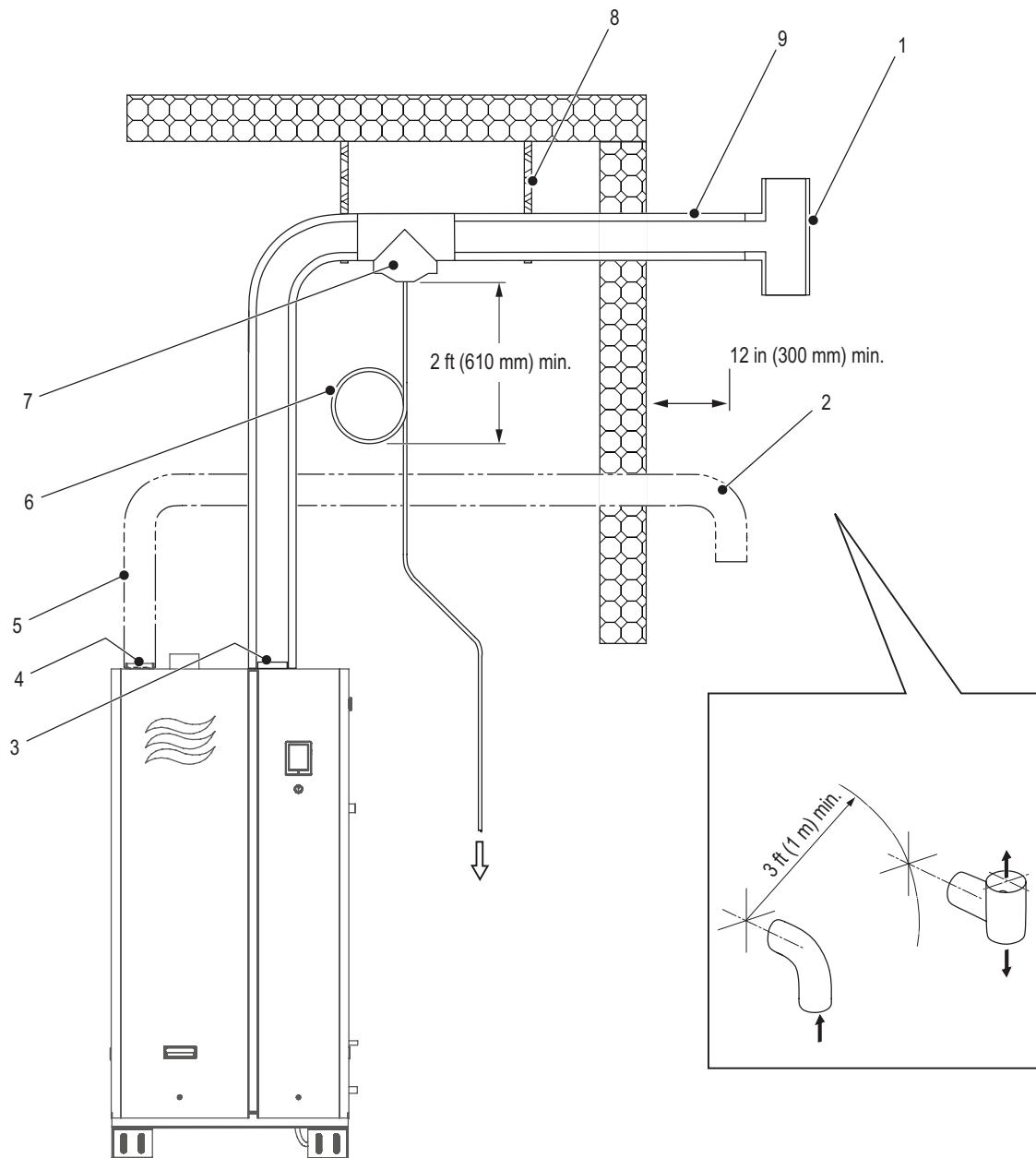

Figure 21: Horizontal Venting (with Optional Sealed Combustion Hookup) – Category IV

- 1 Terminal, exhaust ("Tee")
- 2 Terminal, air intake (90° elbow) – pointed down, for optional sealed combustion hookup
- 3 Outlet, exhaust outlet
- 4 Inlet, air intake
- 5 Vent, air intake – for optional sealed combustion horizontal hookup
- 6 Drain, condensate (with trap) – minimum 12 in (300 mm) trap height, and connected to floor drain or condensate pump
- 7 "Tee", condensate
- 8 Hanger
- 9 Vent, exhaust, type BH – refer to [Table 16 on page 51](#) for vent details. All joints air and water-tight. Full condensate "Tee" with condensate port and trap.

5.8.2 Exhaust Vent Installation for CS/NX Model

5.8.2.1 Installation as a Category IV Appliance

The Nortec GS CS/NX model humidifier must be installed as a Category IV fan-assisted gas appliance. In addition to the specific requirements described in this section, refer to [“General Requirements” on page 50](#).

The exhaust outlet on the unit has a female connection (metric size). Each unit is supplied with a metric-to-imperial adaptor (with internal gaskets) to accommodate imperial vent sizes.

To connect the exhaust vent, first insert the adaptor into the exhaust outlet and secure it to the top panel with four sheetmetal screws (supplied) – refer to [Figure 22](#). Then slide the exhaust vent into the adaptor until it bottoms out, and secure it with the clamp built into the adaptor. A sealant is not required.

Make sure that the exhaust vent is supported by hangers or pipe straps so that there is no load on the humidifier.

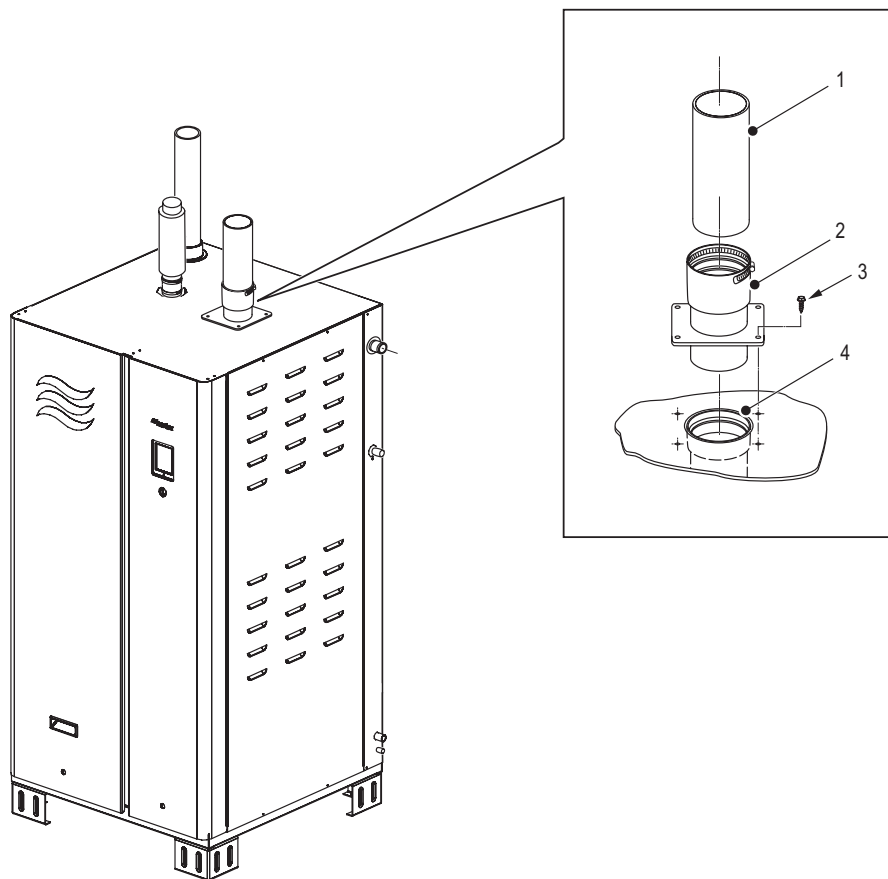

Figure 22: Nortec GS Exhaust Vent Connection – CS/NX Model (Category IV Appliance)

- 1 Vent, exhaust – CPVC or type BH (CPVC only for GS 50-CS/NX)
- 2 Adaptor, exhaust (metric-to-imperial) – plastic (supplied)
- 3 Screw, sheetmetal (×4, supplied)
- 4 Outlet, humidifier exhaust

The following requirements must be satisfied when the Nortec GS CS/NX model humidifier is installed as a Category IV appliance:

- Category IV appliances can be vented vertically or horizontally, and can terminate on a rooftop or sidewall provided they meet the requirements of the National Fuel Gas Code (ANSI Z223.1), or CAN/CGA B149 Installation Codes. Refer to [Figure 20 on page 53](#) and [Figure 21 on page 54](#). Adhere to vent manufacturer's instructions.
- Refer to [Table 16 on page 51](#) for vent type and diameter of the exhaust vent for this type of installation. The vent diameter must remain uniform over the entire run.
- The Nortec GS CS/NX model humidifier can be installed with type BH or plastic vents. Plastic pipe (CPVC certified to ULC-S636) is preferred. Type BH vent, if used, must be UL or UL/CSA-listed.
Note: The Nortec GS 50-CS/NX must only use CPVC plastic pipe.
- The recommended manufacturer for CPVC plastic pipe is IPEX Inc.
- The following is a list of recommended stainless steel type BH vent manufacturers:
 - a. Flex-L International Inc.
 - b. FasNSeal
 - c. Heat-Fab Inc.
 - d. Z-Flex
- The exhaust vent must not connect to a common vent that is shared with any other natural gas appliance or power-assist appliance.
- The exhaust vent must not share a chimney flue servicing an appliance designed to burn solid fuel.
- All joints must be sealed using a sealant recommended by the vent manufacturer.
- The exhaust vent must have a minimum equivalent length of 10 ft (3 m), and must not exceed an equivalent length of 100 ft (30 m), except for the Nortec GS 50 using propane gas which is limited to 50 ft (15 m). The pipe diameter must remain uniform over the entire run. The vent run should be as direct as possible with no more than six elbows in the system. Each 90° elbow is equivalent to 10 ft (3 m), and each 45° elbow is equivalent to 5 ft (1.5 m) of straight pipe.
- Exhaust vents used in sealed combustion applications must not exceed an equivalent length of 100 ft (30 m), except for the Nortec GS 50 using propane gas which is limited to 50 ft (15 m).
- The maximum operating flue temperature is 160 °F (71 °C). Normal operating range is 120-140 °F (49-60 °C).
- During normal operation, a Category IV appliance will create exhaust condensate. Install condensate drain lines according to vent manufacturer's instructions every 15 ft (4.5 m) on all horizontal runs, and at every horizontal-to-vertical transition. Install a full "Tee" with condensate port and trap at all horizontal-to-vertical transitions. The condensate trap must be minimum 12 in (300 mm) in diameter. Refer to [Figure 20 on page 53](#) or [Figure 21 on page 54](#).
- Install condensate neutralizer, if required by local code.

5.9 Gas Connection

Gas piping must meet the requirements of the National Fuel Gas Code (ANSI Z223.1) in the USA, or CAN/CGA B149 Installation Codes in Canada, or applicable gas supply pressure requirements of the local building codes.

Refer to “[Site Requirements](#)” on page 24 for the gas supply requirements. For gas connection sizes refer to [Table 8](#) on page 26. In addition, refer to “[Gas Connection Requirements](#)” on page 58.

IMPORTANT! Tampering with the gas valve, without the express consent of Condair, will void the warranty.

5.9.1 Gas Connection, Compact and Full-Size Unit

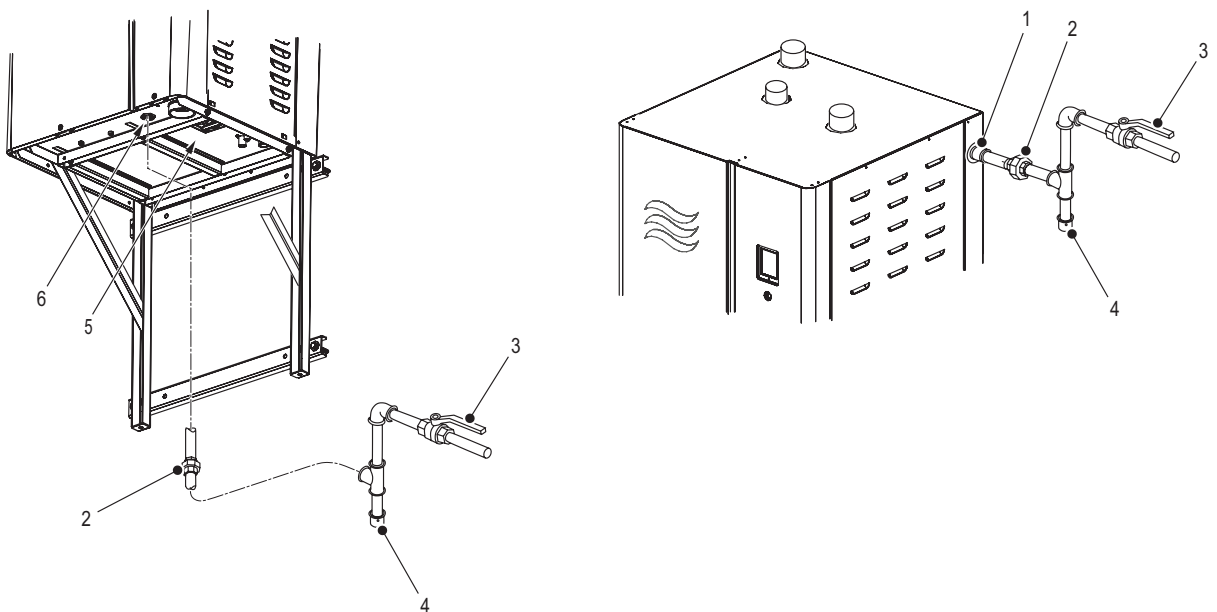

Figure 23: Gas Connection

- 1 Inlet, gas, NPT female (full-size unit) – see note below
- 2 Fitting, union (not supplied)
- 3 Valve, manual gas shutoff (not supplied)
- 4 Trap, sediment (not supplied)
- 5 Maintenance access for drain pump – do not obstruct
- 6 Inlet, gas, NPT female (compact unit)

Note: For Nortec GS 450/600 only, the gas line will require a 1-1/4 to 1 in NPT adaptor (not supplied) to connect to the inlet gas connection on the unit..

5.9.2 Gas Connection Requirements

In addition to the requirements of the applicable national and local codes for gas connections, the following requirements must also be satisfied:

- A certified manual gas shutoff valve must be installed immediately upstream from the humidifier. Refer to [Figure 23](#).
- For gas inlet size and gas line size refer to [Table 8 on page 26](#).
- If black pipe is used, a sediment trap must also be installed immediately upstream from the humidifier.

IMPORTANT! Route the gas line so that it does not obstruct access to any of the services to the humidifier. On the compact unit, make sure that the maintenance access for the drain pump is not obstructed.

- DO NOT use teflon tape on gas line pipe threads. A flexible sealant suitable for use with natural gas and propane gas is required.
- All gas piping must be adequately supported to prevent any strain on the humidifier gas connection.
- Upon completion of the gas installation, perform the “[Gas Leakage Test](#)” described below.

5.9.3 Gas Leakage Test



DANGER!
Risk of explosion and fire!

Prevention: NEVER use an open flame to check for gas leaks. Risk of injury, death or property damage. Use a commercial soap solution or a gas sniffer to check for leaks.



CAUTION!
Risk of damage to the gas valve!

Prevention: Before performing the leakage test described below, close the manual gas shutoff valve at the humidifier to isolate the gas valve from system pressure. Failure to do so may damage the gas valve, and will void warranty.

1. Close the manual gas shutoff valve at the humidifier.
2. Pressurize the gas supply line to a maximum of 14 in H₂O (3.5 kPa), and test all gas connections external to the humidifier for leaks using a commercial soap solution or a gas sniffer. Seal all leaks before operating the humidifier.
3. After completing the leakage test, de-pressurize the gas supply line BEFORE opening the manual gas shutoff valve.

5.9.4 Gas Connection Checklist

Check the following to ensure that the gas connection for the humidifier has been installed correctly:

- Certified manual gas shutoff valve installed immediately upstream from the humidifier?
- Sediment trap installed (if using black pipe)?
- Gas pipe routing allow clear access to other service connections at humidifier?
- Gas piping adequately supported?
- Gas leakage test completed, and all leaks fixed?
- De-pressurize gas supply line after leak test?

5.10 Humidity Control Systems

5.10.1 Control Device Locations

The following schematic describes a potential system setup with respect to control devices. Refer to [Figure 24](#),

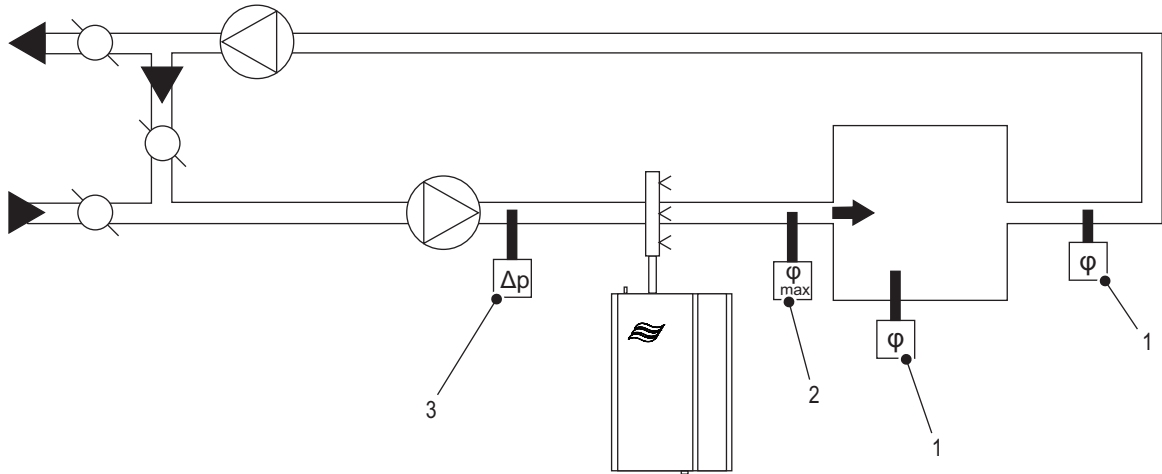

Figure 24: System Setup Schematic

- 1 Humidistat or humidity sensor
- 2 High limit humidistat or humidity sensor
- 3 Switch, air proving

Notes:

- Locate the air proving switch in the same duct as the humidifier's distributor so that it can sense air flow (or lack thereof).
- Locate the high limit humidistat downstream of the humidifier's distributor so that it can sense a duct that is over-humidified. Recommended setting is 85% RH. Locate it downstream of the distributor – at least 5x the absorption distance away. If the absorption distance is not known, locate it at least 10 feet (3 m) downstream from the distributor. Can be a humidistat (modulating or On/Off), or a humidity sensor.
- Humidity sensors and humidistats can be modulating or On/Off. Preferred location is in the return duct, as the supply air is well mixed with the room air at this location. Avoid placing near discharge diffuser, near doorways, in sunlight, or in airflow "dead-zones".

5.10.2 Permissible Control Signal Inputs

Table 18 shows the different permissible control signal inputs the Nortec GS humidifier can handle.

Table 18: Permissible Control Signal Inputs

Humidity Control with External Controller Control Signals	Humidity Control with Internal PI Controller Humidity Sensor Signals	Digital Inputs (via Modbus, BACnet IP/MSTP slave)
0-5 VDC (potentiometer 135-10kΩ) 1-5 VDC 0-10 VDC 2-10 VDC 0-20 VDC 0-16 VDC 3.2-16 VDC 0-20 mA 4-20 mA	0-5 VDC (potentiometer 135-10kΩ) 1-5 VDC 0-10 VDC 2-10 VDC 0-20 VDC 0-16 VDC 3.2-16 VDC 0-20 mA 4-20 mA	BACnet IP BACnet MSTP Slave Modbus Lonworks (Option) BACnet MSTP BTL Certified (Option) BACnet IP BTL Certified (Option)
Humidistat (24 V On/Off)		

5.11 Electrical Connections

Refer to “[Site Requirements](#)” on page 24 for the electrical requirements.

Install the electrical connections according to the wiring diagram(s) ([Figure 25 on page 63](#), and [Figure 26 on page 64](#), as applicable) and the instructions for “[External Connections](#)” on page 65.

For connecting multiple Nortec GS humidifiers, refer to “[Connecting Multiple Units Using Linkup](#)” on page 71.

5.11.1 General

Safety

The electrical installation work requires removal of the access panels in the humidifier. Observe the following safety precautions:



DANGER!
Risk of electric shock!

The Nortec GS humidifier is mains powered. Live parts may be exposed when the access panels are removed. Touching live parts may cause severe injury or even death.

Prevention: The Nortec GS humidifier must be connected to the mains only after all installation work has been completed, checked for correct workmanship, and the access panels are installed and fastened securely.



CAUTION!
Electrostatic discharge (ESD)!

The electronic components inside the humidifier are sensitive to electrostatic discharge (ESD).

Prevention: Take appropriate measures to protect the electronic components inside the unit against damage caused by electrostatic discharge (ESD). Refer to ANSI/ESD-S20.20.

- All electrical installation work must be performed only by a licensed electrician authorized by the customer. It is the customer’s responsibility to verify qualifications of the personnel.
- The electrical installation must be performed according to the wiring diagrams in this manual, the instructions in this section, as well as applicable national and local codes.
- Make sure that the main power cable is properly grounded through the ground lug inside the control cabinet. When installed, the appliance must be electrically grounded in accordance with local codes or, in the absence of local codes, with the National Electrical Code (ANSI/NFPA70) in the USA, and/or CSA C22.1 Electrical Code in Canada.
- Field wiring from the humidistat to the humidifier and between devices must be shielded minimum 18 AWG, and shall conform with temperature rise limitation of 63 °F (35 °C) for Type-T wire.
- All cables must lead into the unit, via appropriate strain relief connectors, and be secured with clamp straps.
- Make sure the cables are secured, and do not rub on any components or become a tripping hazard.
- Adhere to national and local codes for maximum cable length and required wire sizes for cables.

5.11.2 Wiring Diagrams

5.11.2.1 Nortec GS 50/100/150/200/300/450/600

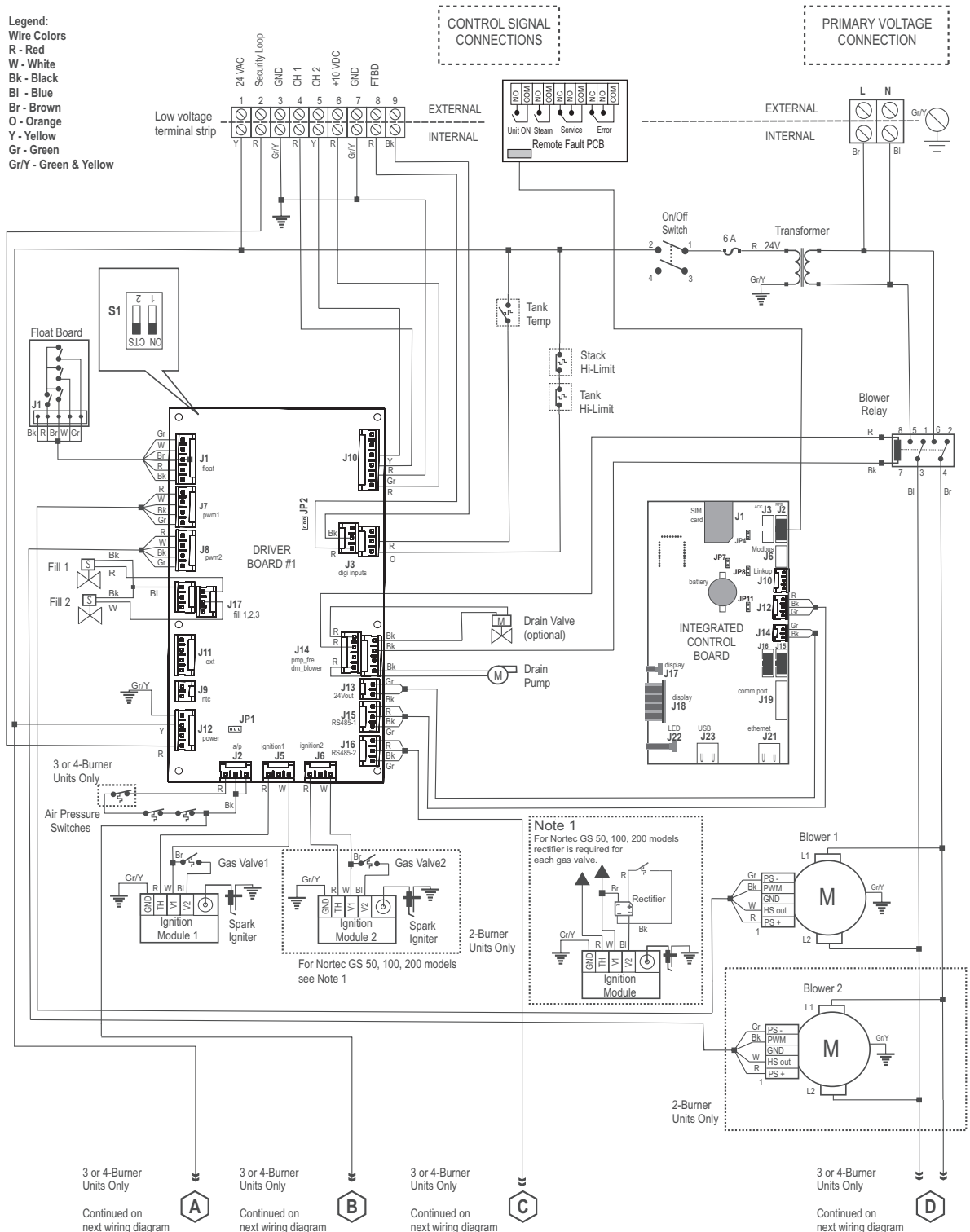

Figure 25: Wiring Diagram - Nortec GS 50/100/150/200/300/450/600

JP4 Jumper – for activating the termination resistor for Modbus or BACnet MSTP network.

J6 Connector, Modbus (RS485 interface)

JP7 Jumper – for activating Modbus or BACnet MSTP communication via connector J6.

JP8 Termination, Linkup system

J10 Connector, Linkup

5.11.2.2 Nortec GS 450/600

Figure 26 shows the supplementary wiring diagram for the Nortec GS 450 and Nortec GS 600. The connections are carried over from Figure 25 on page 63.

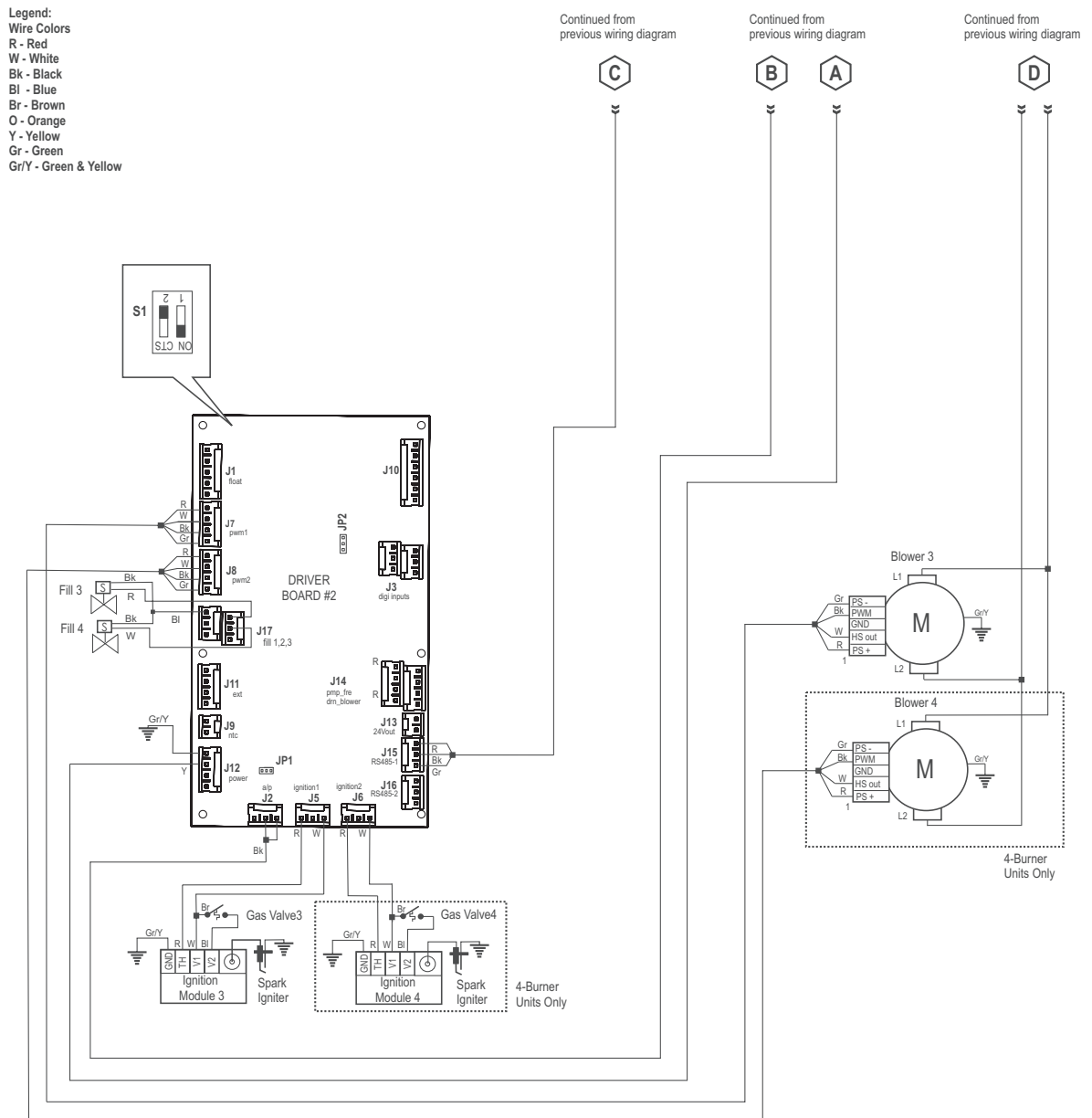

Figure 26: Wiring Diagram - Nortec GS 450/600

5.11.3 External Connections

This section describes the different external control signal and power connections to the Nortec GS humidifier.



CAUTION!
Risk of improper operation, or damage to equipment and property!

Prevention: Before disconnecting the control signal cables, tag all wires. Reconnect all wires properly after servicing.

5.11.3.1 External Security Loop

The external security loop consists of dry contacts of the external monitoring devices (for example, ventilation interlock, high limit humidistat, air proving switch, etc.). Connect the external safety devices in series to pins "1" and "2" in the low voltage terminal strip. Refer to [Figure 25 on page 63](#) and [Figure 27](#).

IMPORTANT! A high limit humidistat is highly recommended to prevent over-humidification and potential damage to property.

IMPORTANT! Install a jumper between pins "1" and "2" in the low voltage terminal strip if no external On/Off devices are connected to the security loop.

The connecting cables must lead into the control cabinet through a cable gland or grommet.



CAUTION!
Risk of damage to internal components!

Prevention: DO NOT apply voltage to low voltage terminal strip pins "1" and "2" through the contacts of the external On/Off devices.

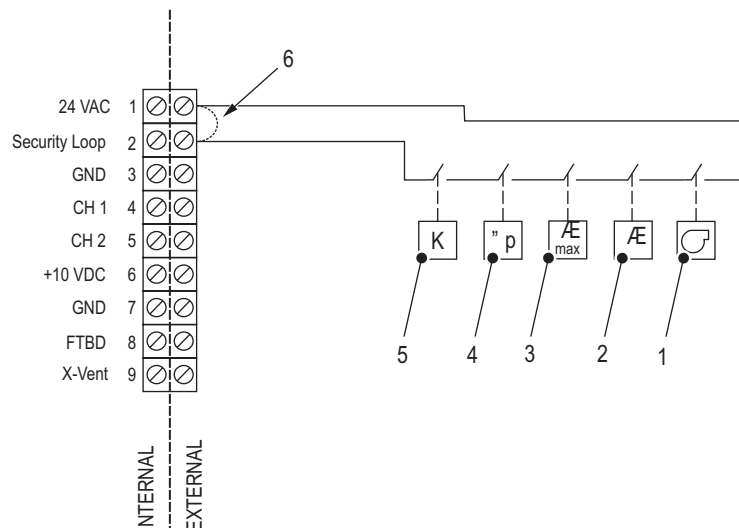

Figure 27: External Security Loop Connections

- 1 Blower pack
- 2 Humidistat, On/Off
- 3 Humidistat, high limit
- 4 Switch, air proving
- 5 Interlock, ventilation
- 6 Jumper (installed if no devices connected to security loop)

5.11.3.2 Modulating Demand or Humidity Signal

Connect an external humidity sensor input or direct demand modulating input to pins "3" and "4" in the low voltage terminal strip. Refer to [Figure 25 on page 63](#) and [Figure 28](#). The permissible control signal input values are shown in [Table 18 on page 61](#).

Do not connect multiple modulating signals to the same modulating input on the humidifier. If necessary, connect the second modulating signal to pin "5" and "3", using pin "3" as common. Make sure that Control Channels is set to "Dual" in the control software to utilize the second modulating signal – refer to the Operation and Maintenance Manual.

Alternately, transducer signals or demand signals can be written to the humidifier via a valid digital communication protocol.

The signal cable must lead into the control cabinet through an appropriate strain relief connector. If a shielded signal cable is used, connect the shielding to pin "3".

! CAUTION!

If the shielding of the signal is already connected to a potential or a grounded conductor, do not connect it to pin "3".

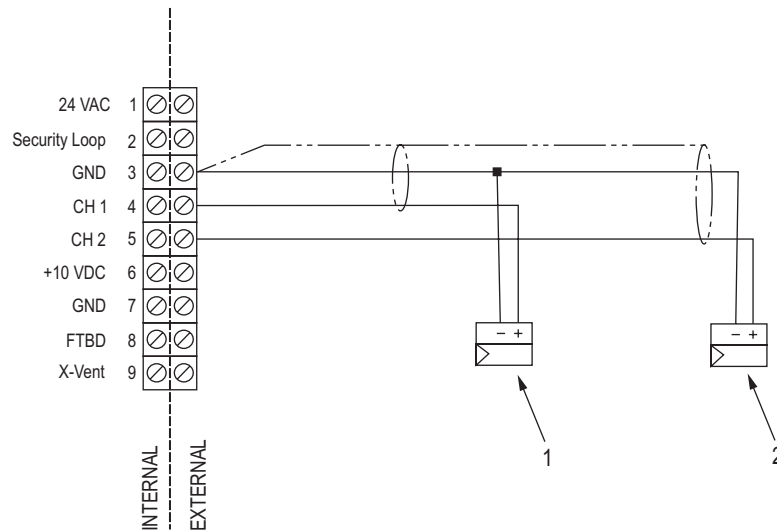

Figure 28: Modulating Demand or Humidity Signal Connections

- 1 Modulating demand or humidity sensor signal
- 2 Modulating high limit demand or humidity sensor signal (additional, for Dual channels)

5.11.3.3 On/Off Humidistat Signal

If an On/Off humidistat is used, connect the signal cable to terminal pins "4" and "6" in the low voltage terminal strip. Refer to [Figure 29](#). Set Control Mode must be set to "On/Off" in the control software – refer to the Operation and Maintenance Manual.

IMPORTANT! When connecting a 24 VDC On/Off humidistat, jumper JP2 on the driver board must be set to 24 V (so that pin "6" will output 24 VDC).

Note: By default the jumper JP2 is set to 10 VDC, so that the output can also be used for test purposes.

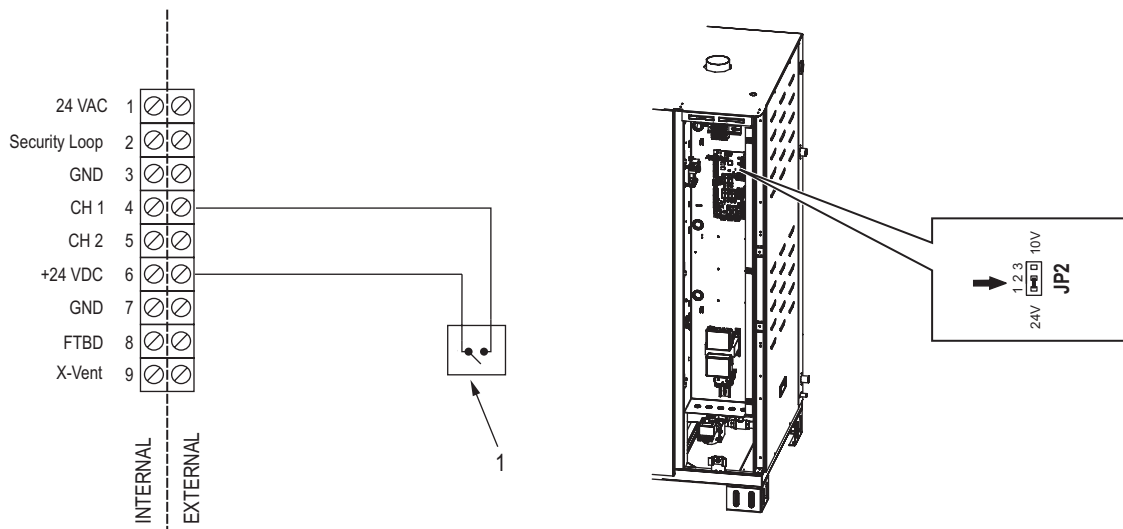

Figure 29: 24 V On/Off Humidistat Connection

1 Humidistat, 24 VDC On/Off

5.11.3.4 Full Tank Blowdown Signal Connection

If an external full tank blowdown signal is used, connect the 24 VAC input signal to pins "1" and "8" in the low voltage terminal strip. Refer to [Figure 30](#).

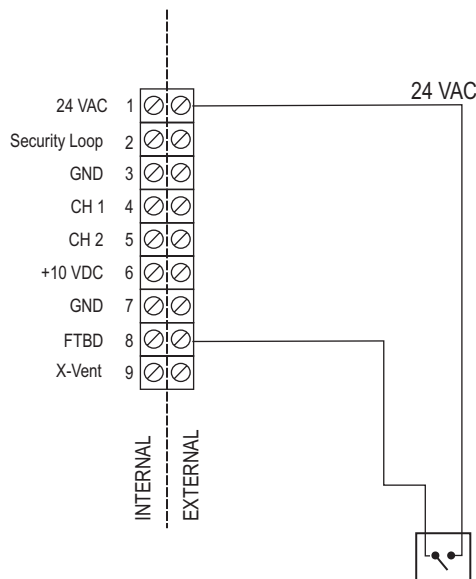

Figure 30: Full Tank Blowdown Signal Connection

5.11.3.5 Remote Fault PCB Connections

The remote fault PCB (printed circuit board) in the Nortec GS humidifier has the following four dry relay contacts for remote display of humidifier status and fault conditions. Refer to [Figure 31](#) for the relevant terminal contacts.

- Error – this relay can be wired to open (NC) or close (NO) when a fault is detected by the humidifier controls.
- Service – this relay is activated when the set maintenance interval elapses. It can be wired to open (NC) or close (NO) when a warning appears on the touchscreen panel of the humidifier and the status LED turns yellow in color.

Note: This relay can be configured in the control software to indicate status updates or system warnings – refer to the Remote Fault Board tab in the Operation and Maintenance Manual.

- Steam – this normally open (NO) relay closes when the unit is producing steam.
- Unit on – this normally open (NO) relay closes when the humidifier has power, and the On/Off switch is in the On position.

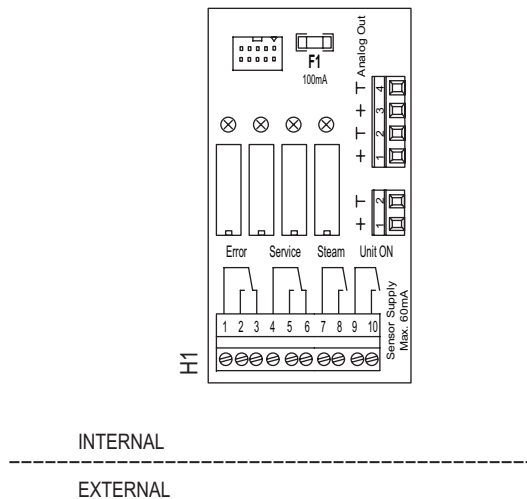

Figure 31: Remote Fault PCB Connections

The remote relay PCB connects to the connector J2 on the Nortec GS control board.

5.11.3.6 Single-Phase Power Supply Connection

Connect the single-phase power supply to the Nortec GS humidifier as shown in [Figure 32](#). Refer to the specification label ([Figure 3 on page 16](#)) for power requirement and sizing of fused disconnect switch.

IMPORTANT! Make sure that the main power cable is properly grounded through the ground lug inside the control cabinet.

All wiring must be in accordance with national and local electrical codes.

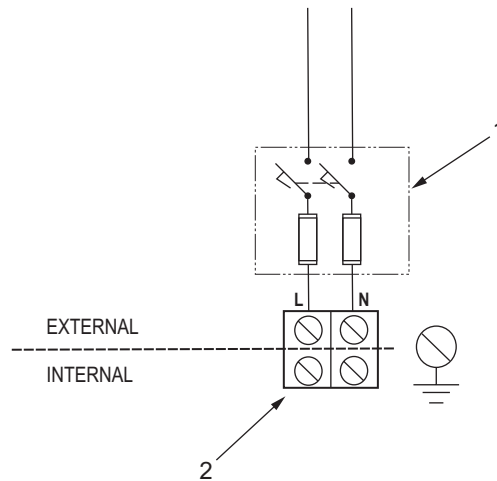

Figure 32: Single-Phase Power Supply Connections

- 1 Switch, disconnect, external fused
- 2 Terminal block, power supply

5.11.3.7 Modbus Connection

The Nortec GS humidifier comes standard with a Modbus communications interface, which can be used to remotely control its output or monitor its operation.

Refer to [Figure 33](#) and connect the Modbus communication cable to the Nortec GS humidifier as follows:

1. Connect a Modbus cable to the connector J6 on the Nortec GS control board. Refer to [Table 19](#) for Modbus cable requirements, and [Table 20](#) for communication parameters. Contact your Condaire representative if assistance is needed to change the default communication parameters.

Note: The jumper JP7 on the control board must be installed to activate Modbus or BACnet MSTP communication via RS485 interface (J6). If the jumper is not installed, no communication will take place through J6.

2. Install the jumper JP4 on the control board if the Nortec GS humidifier is the first or last unit in the network.

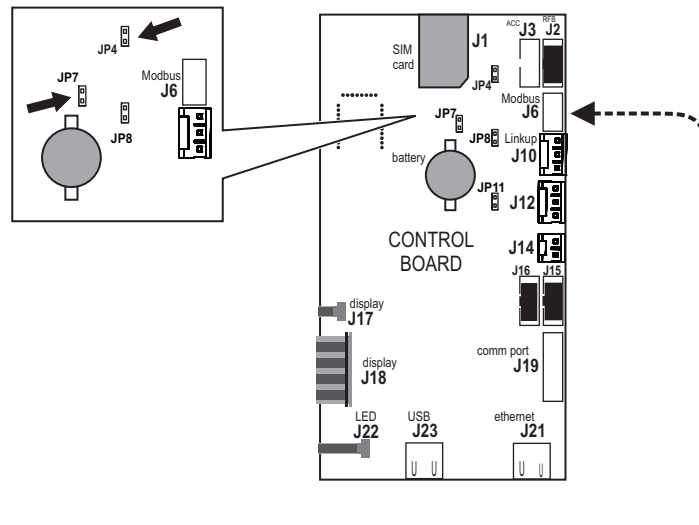

Figure 33: Modbus Connection on Nortec GS Humidifier

JP4 Jumper – for activating the termination resistor for Modbus or BACnet MSTP network

J6 Connector, Modbus (RS485 interface)

JP7 Jumper – for activating Modbus or BACnet MSTP communication via RS485 interface (J6)

Table 19: ModBus Cable Requirements

BMS Protocol	Signal Type	Recommended Cable	Maximum Distance from humidifier to BMS
Modbus	EIA-485, 2-wire	18-24 AWG shielded, twisted pair, 120Ω *	2200 ft (670 m)

* Connect humidifiers in a daisy chain to the Modbus RTU. Ground shield at on end only – either at the BMS or the humidifier.

Table 20: Modbus Communication Parameters

Parameter	Default	Adjustable Range
Signal type	EIA-485	–
Transmission mode	RTU	–
Baud rate	9600	110, 300, 600, 1200, 2400, 4800, 9600, 19200, 38400, 57600, 76800 or 115200
Data bits	8	–
Stop bits	1	–
Parity	Even	Odd, Even, None
Address	10	1-247
Time out	300 s	1-300 s

5.11.4 Connecting Multiple Units Using Linkup

The integrated control board in the Nortec GS humidifier allows up to four integrated controllers to connect in a "main-extension" configuration using Condaire's Linkup system. All the humidifiers within this setup must share the same environment, and be controlled by one set of control signals connected to the main unit.

Refer to [Figure 34](#) and connect multiple unit using Linkup as follows:

1. Connect all control signals for the entire Linkup configuration to the low voltage terminal strip in the main unit.
2. Install a jumper wire between the pins "1" and "2" in the low voltage terminal strip on all extension units.
3. Connect a multi-strand twisted pair shielded cable (18-24 AWG, 120 Ω) between the J10 connectors on the control board of each Nortec GS humidifier in the Linkup system. **Note:** Maximum recommended distance between units is 100 ft (30 m).

IMPORTANT! Do not reverse polarity.

4. Install the termination jumper JP8 in the control board of the last extension unit in the Linkup system.
5. Finally, refer to the Operation and Maintenance Manual to set up the multi-unit configuration in the control software.

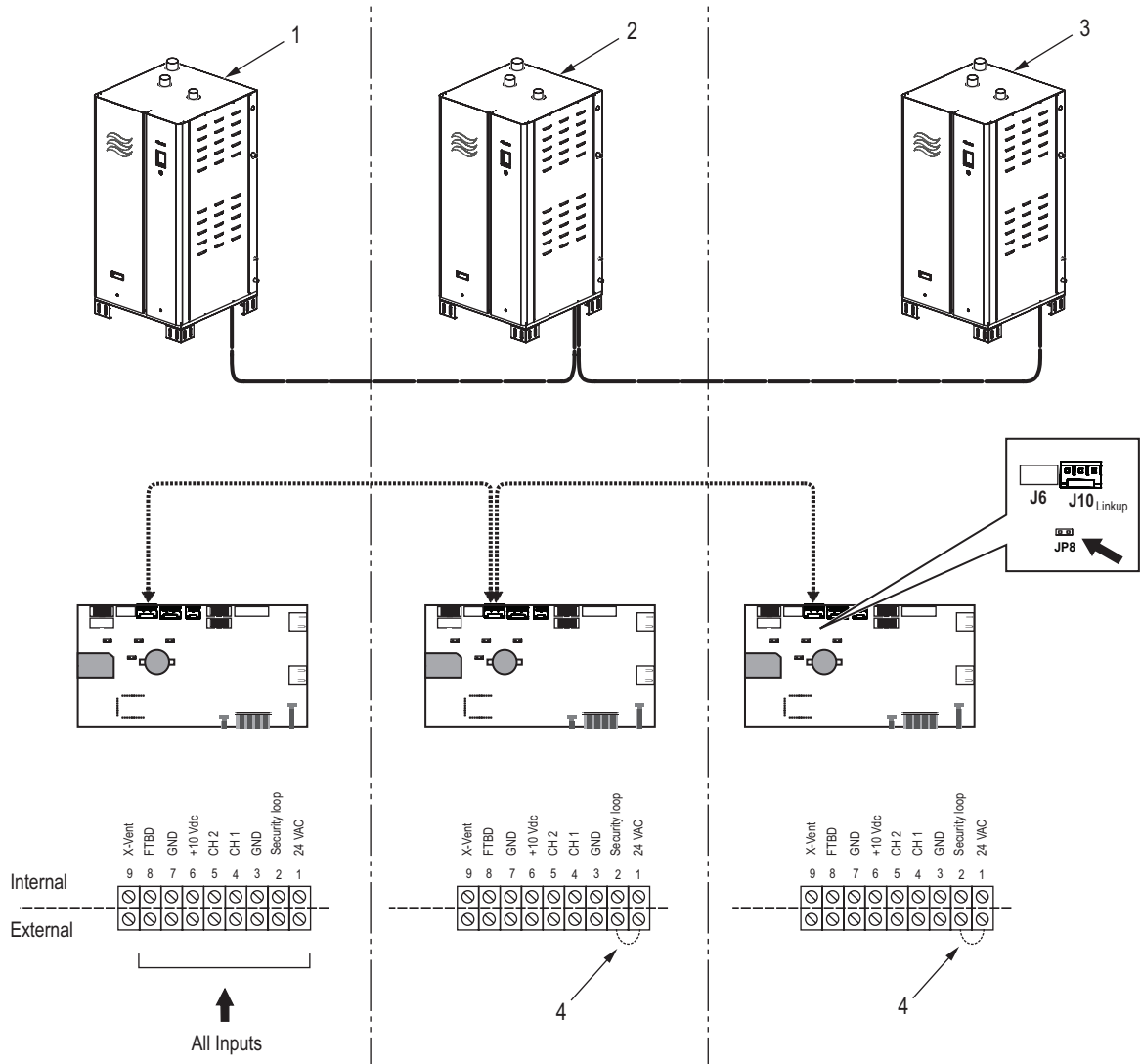

Figure 34: Multi-Unit Linkup Connections

- 1 Main unit (all control signals to unit)
- 2 Extension unit #1 (no control signals to unit)
- 3 Extension unit #X (no control signals to unit)

5.11.5 Electrical Connections Checklist

- Check the following to ensure that the electrical connections for the humidifier have been installed correctly:
- Power supply meet the rated current draw limits shown on the specification label ([Figure 3 on page 16](#))?
- Power supply have an external dedicated fused disconnect switch?
- All wiring done according to the wiring diagram and instructions in this manual?
- Main power cable proper grounding through the ground lug inside the electric cabinet?
- All cables fastened securely?
- All cables free of tension and pass through cable glands or grommets?
- Electrical installation meet the applicable national and local codes?
- All access panels closed and fastened securely?

6 Product Specifications

6.1 Weights

For the weights of the Nortec GS humidifier models refer to [Table 13 on page 23](#).

6.2 Dimensions

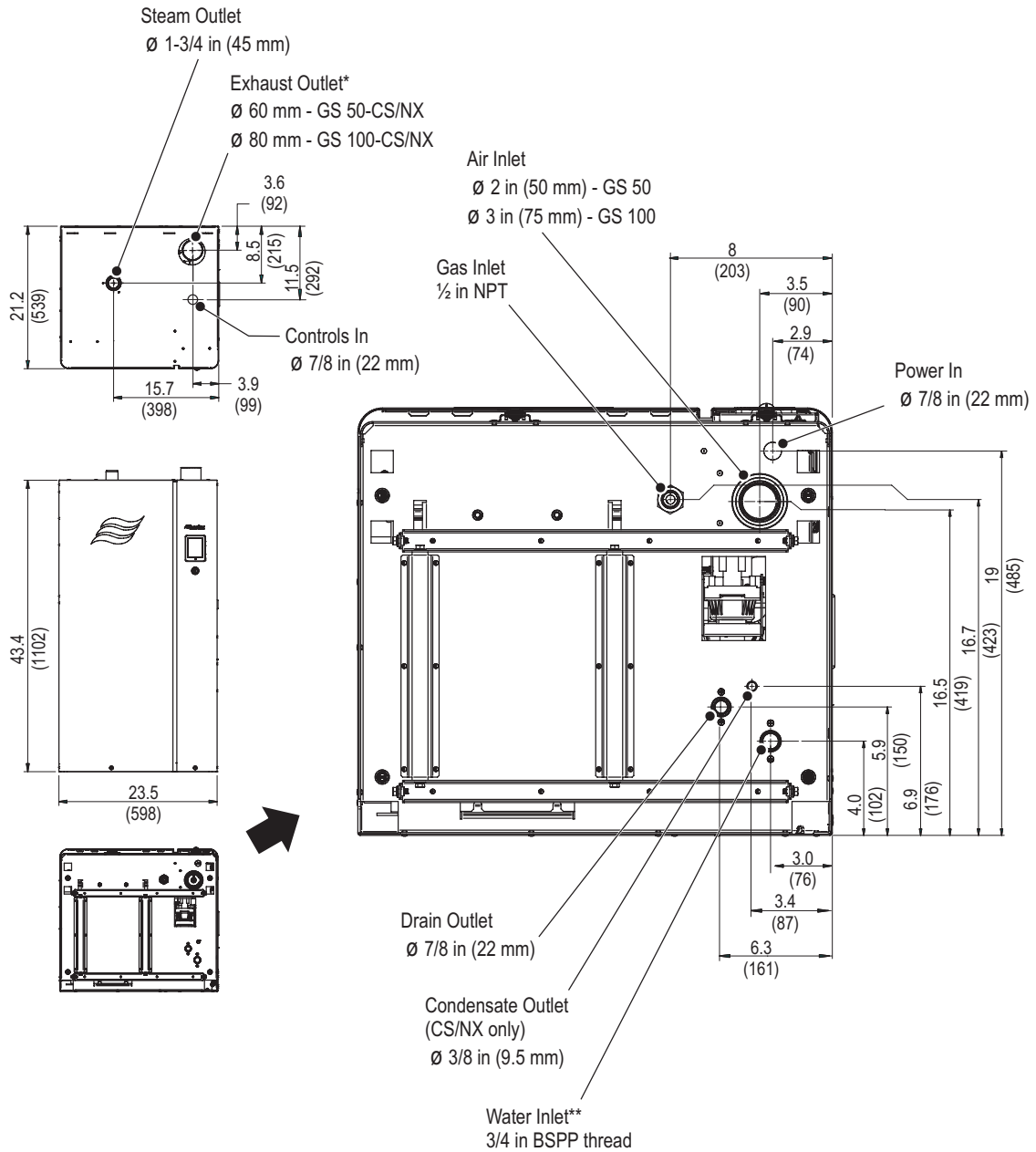

* Metric to imperial size adaptor supplied with unit

** BSPP to NPT adaptor supplied with unit

Figure 36: Nortec GS 50/100

Dimensions are shown in inches, and values in brackets are in millimeters.

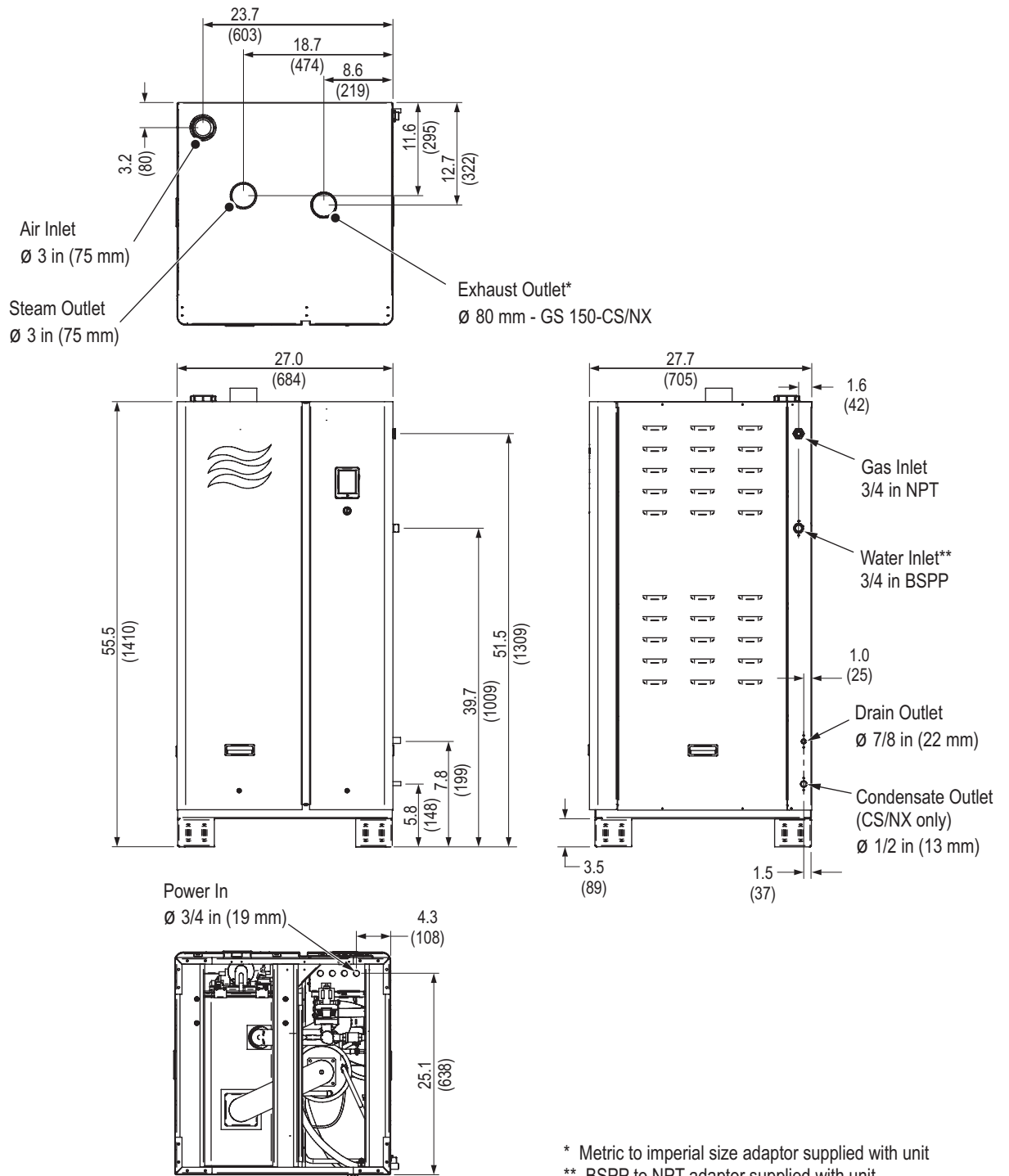

* Metric to imperial size adaptor supplied with unit
 ** BSPP to NPT adaptor supplied with unit

Figure 37: Nortec GS 150

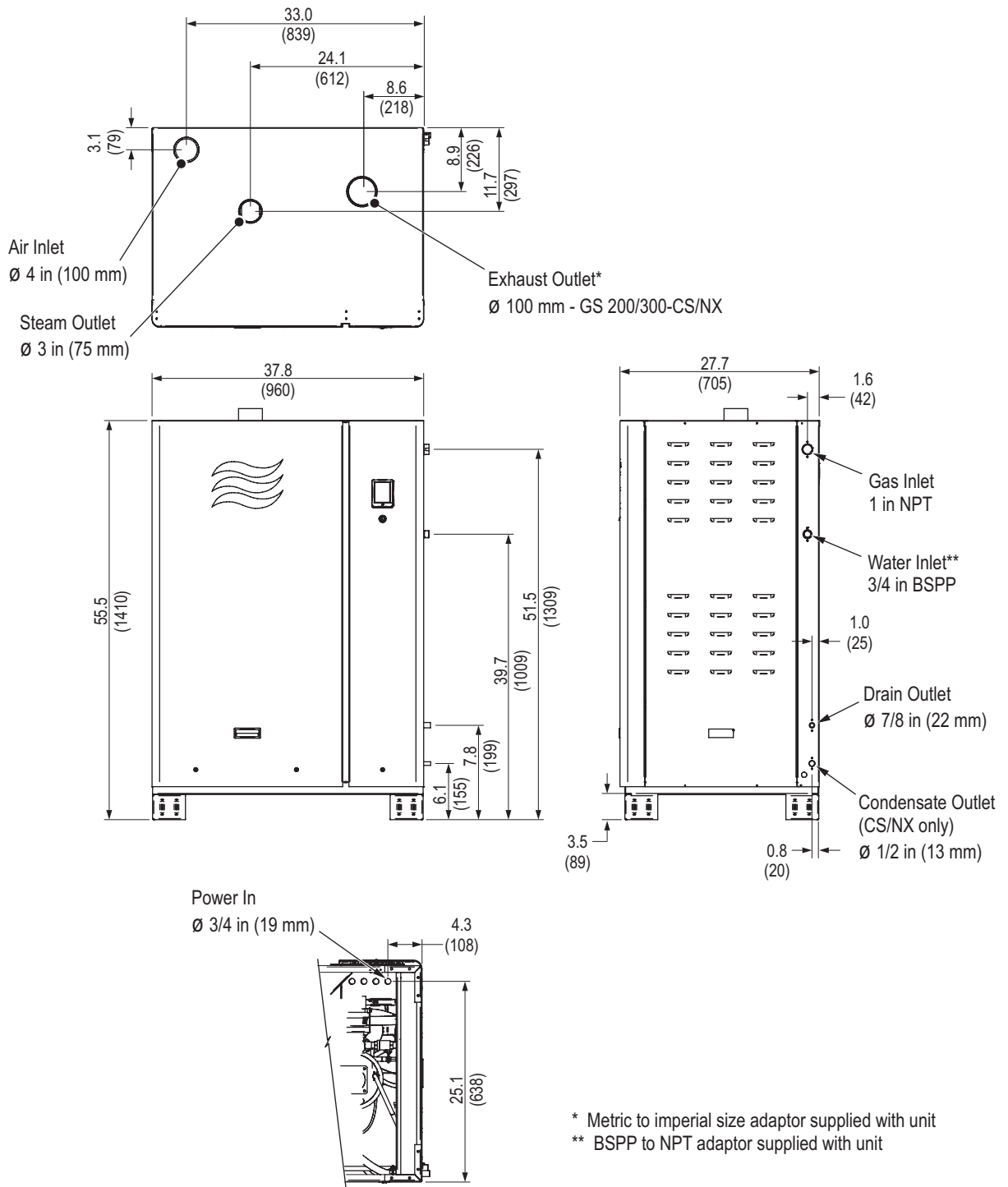

Figure 38: Nortec GS 200/300

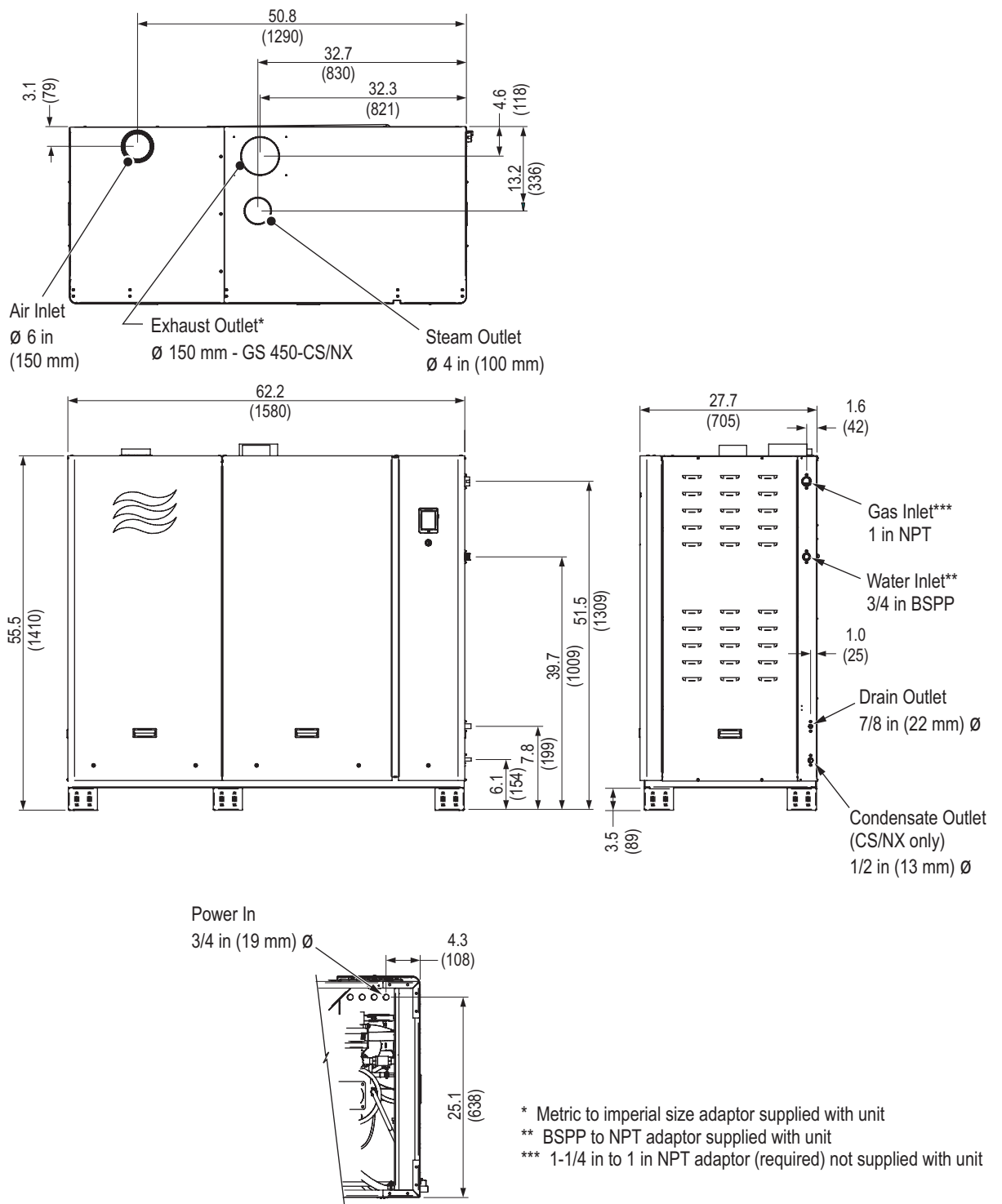

Figure 39: Nortec GS 450

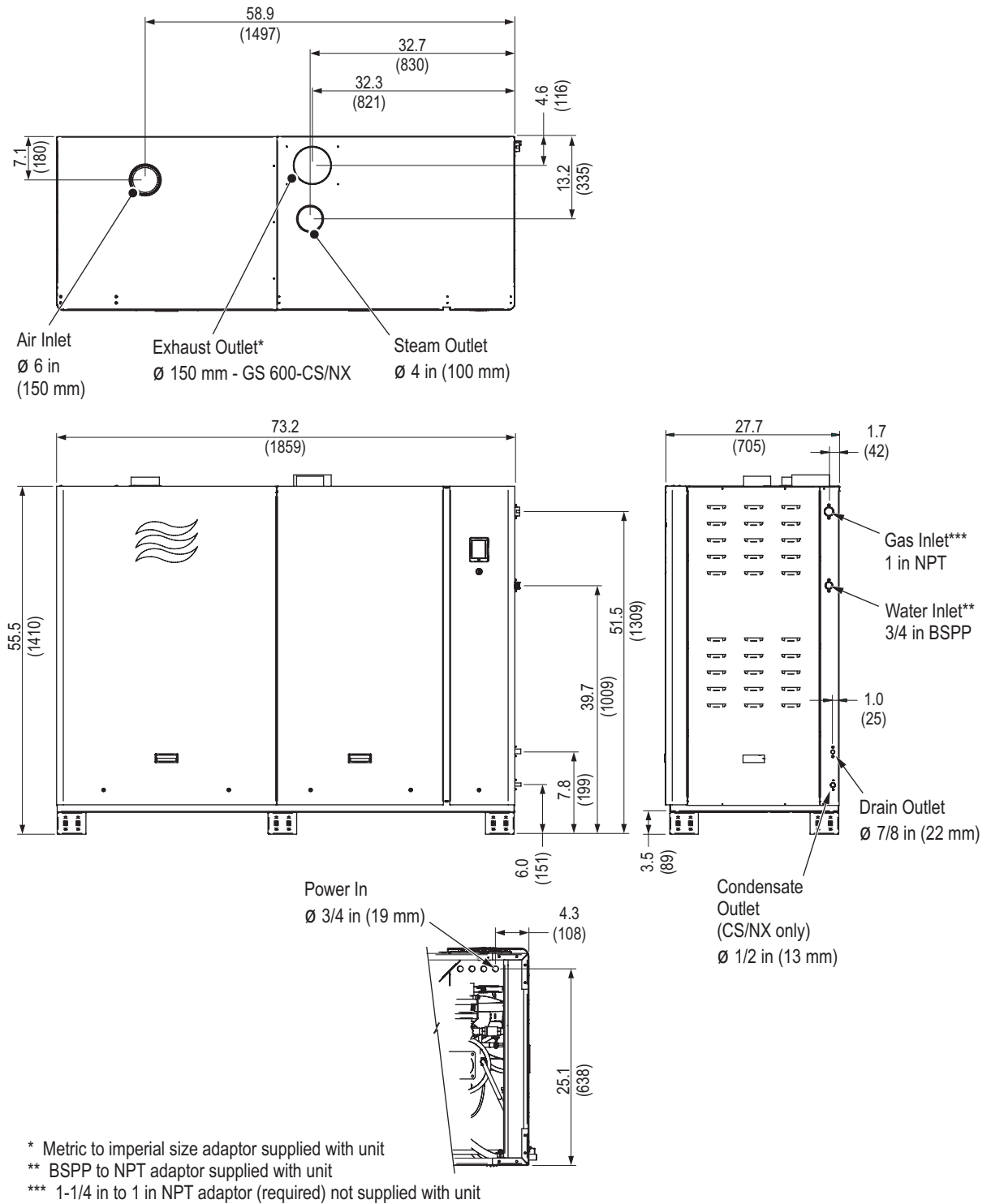

Figure 40: Nortec GS 600

This page intentionally left blank

A Appendix

A.1 Installation Checklist

The following is a consolidated installation checklist that can be used in the commissioning of the unit:

Mounting

- Unit installed in the correct location (according to "[Clearances](#)" on page 22)?
- Adequate clearance for servicing unit?
- Mounting surface stable, and capable of supporting the full operating weight of the humidifier?
- Unit level?
- Unit secured properly?

Steam Line

- Observed all best practices?
- Steam pipe sized correctly?
- The steam line does not exceed maximum equivalent length listed in [Table 14](#) on page 32?
- Long radius elbows (for rigid pipes) used?
- Backpressure in the line combined with duct static pressure does not exceed 6 in H₂O (1.49 kPa) for compact units, or 10 in H₂O (2.49 kPa) for full-size units?
- Steam line runs straight up from the humidifier steam outlet for at least 12 in (300 mm) before bend?
- Steam line has minimum upslope of 10°, or minimum downslope of 2°?
- Steam line does not reduce in diameter except at the steam distributor; and condensate line installed just before the restriction?
- Steam lines do not merge except at the steam distributor through a Condair adaptor?
- Steam line does not sag?
- Steam connections secured with clamps? Clamps torqued adequately?
- Allowances made for thermal expansion of rigid pipes, and shrinkages of steam hose?
- Steam line insulated over its entire length?

Condensate Line

- Local regulations on drain water temperature requirements have been satisfied?
- Condensate traps installed at all low points, and at horizontal-to-vertical transitions in the steam line?
- Condensate lines in the steam line always connect to full-size "Tee" connectors?
- Condensate traps have a minimum loop diameter of 12 in (300 mm) and installed at least 12 in (300 mm) below the condensate "Tee" and the steam distributor?
- All condensate lines have a minimum downslope of 1.2°?
- Condensate traps installed at regular intervals on long runs exceeding 15 ft (4.5 m)?
- Condensate lines have individual traps before emptying to a common condensate drain? Condensate drain sized appropriately to handle all the condensate?
- Condensate traps primed with water?

Water Connections

- Water quality meet the requirements listed in [Table 8 on page 20](#)?
- Shutoff valve and union fitting installed in supply line?
- Water supply piping to humidifier minimum 1/2 in (13 mm) diameter? Plastic pipe (pressure-proof and certified for use with drinking water systems), copper or stainless steel if using potable drinking water or RO water? Plastic or stainless steel pipe if using DI water?
- 5 µm water filter (optional, but recommended) installed in the supply line close to the humidifier?
- Water supply temperature 34-60 °F (1-15 °C)? Do not exceed 77 °F (25 °C).
- Water supply surge-protected and pressure regulated to 30-80 psig (207-550 kPa)?
- Double check valve backflow preventer is installed along the water supply line to the unit? Is the double check valve backflow preventer installed, adhering to all applicable local and national installation regulations?
- Check for leaks in the water supply line?
- Air gap funnel in the floor located away (max 3 ft (1 m) from the unit) from the control cabinet in the humidifier?
- Air gap funnel minimum 2-1/2 in (64 mm) in diameter?
- Drain pipe between air gap funnel and building drain have a minimum internal diameter of 1-1/2 in (38 mm)? Copper or stainless steel pipe if using potable drinking water or RO water? Stainless steel pipe if using DI water?
- Drain hose from humidifier empty into the air gap funnel without touching its sides or bottom? Drain hose have a minimum constant downslope of 1.2°, and secured with hose clamp? Drain hose rated for 212 °F (100 °C)?
- Water supply line and drain lines flushed? Strainer in the fill valve free of debris?
- Condensate hose installed (CS/NX models only)? Hose rated for 212 °F (100 °C)?
- Condensate trap inside unit primed with water?

Combustion Air Connection – Space Air Installation

- Fresh combustion air requirements for the room/space ([Table 16 on page 42](#) and all national and local regulations) satisfied?
- Elbow installed at the intake air inlet (on Nortec GS 150-600 units)?

Combustion Air Connection – Sealed Combustion Installation

- All relevant national and local regulations for sealed combustion installation satisfied?
- Intake vent length does not exceed an equivalent length of 100 ft (30 m)? If unit is a Nortec GS 50 using propane gas, is it limited to 50 ft (15 m)? Maximum six bends?
- Vent diameter as listed in [Table 17 on page 43](#), and uniform over the entire run?
- All joints and seams sealed with appropriate sealant?
- Intake vent supported?
- Spacing between air intake terminal and exhaust vent terminal minimum 3 ft (1 m)?
- Intake vent heated and insulated in cold climates?

Exhaust Vent Connection

- Exhaust vent installed to meet all national and local codes, vent manufacturer and Condaire requirements?
- Proper clearances maintained between exhaust vent and combustible materials?
- Exhaust vent diameter as listed in [Table 18 on page 46](#), and uniform over the entire run?

- Exhaust vent length does not exceed an equivalent length of 100 ft (30 m)? If unit is a Nortec GS 50 using propane gas, is it limited to 50 ft (15 m)? Maximum six elbows in the exhaust vent?
- Exhaust vent diameter uniform over the entire run?
- Exhaust vent secured properly with hangers or pipe straps?

Gas Connection

- Certified manual gas shutoff valve installed immediately upstream from the humidifier?
- Sediment trap installed (if using black pipe)?
- Gas pipe routing allow clear access to other service connections at humidifier?
- Gas piping adequately supported?
- Gas leakage test completed, and all leaks fixed?
- De-pressurize gas supply line after leak test?

Electrical Connections

- Power supply meet the rated current draw limits shown on the specification label ([Figure 3 on page 16](#))?
- Power supply have an external dedicated fused disconnect switch?
- All wiring done according to the wiring diagram and instructions in this manual?
- Main power cable proper grounding through the ground lug inside the electric cabinet?
- All cables fastened securely?
- All cables free of tension and pass through cable glands or grommets?
- Electrical installation meet the applicable national and local codes?
- All access panels closed and fastened securely?

This page intentionally left blank

B Appendix

B.1 Commissioning Checklist

The Nortec GS series humidifier must always be commissioned for the first time by a service technician from your local Condaire representative, by a Condaire employee, or by personnel who are well trained and authorized by the customer. It is the customer's responsibility to verify the qualifications of personnel.

The intent of the commissioning checklist is to verify that the humidification system has been installed according to the installation manual.

Commissioning of the Nortec GS humidifier consists of two steps – an inspection of the site services and the installation prior to start-up, and performance tests of the unit. Complete the ["Pre-Start-Up Checklist"](#) below and ["Performance Checklist"](#) on page 88. Enter all notes and exceptions in the space provided on page 89. Retain this copy in the installation manual, and submit a copy of the completed forms to your local Condaire representative.

B.1.1 Pre-Start-Up Checklist

Inspect the site services and the installation, and fill out the form below. **Note:** When filling out the form leave the checkbox un-checked if the item does not apply, or if the requirement is not satisfied.

Serial Number:		Tag:	
Model:		Capacity:	Voltage and Phase:
Customer/Job:		Representative:	
Customer Address:			

Site Ambient Conditions

Ambient temperature: (Permissible range – 41-104 °F (5-40 °C))	
Ambient humidity level: (Permissible range – 5-95% RH, non-condensing)	

Site Water Supply

<input type="checkbox"/>	Well water
<input type="checkbox"/>	City water
<input type="checkbox"/>	Softened water
<input type="checkbox"/>	Reverse osmosis (RO)
<input type="checkbox"/>	De-ionized water (DI)

Refer to [Table 8 on page 20](#) for water quality requirements. **Note:** Run the water for approximately five minutes before performing the tests:

Site Water Quality	Measurement*
Conductivity (µS/cm):	
Hardness (gpg):	
Silica (ppm):	
Chlorides (ppm):	
pH level:	

* Test sample must be collected as close as possible to the fill valve in the humidifier, so that the sample reflects the characteristics of the supply water entering the unit.

Site Water Supply, continued...

Note: For the GS 450/600 units, check water supply to each dual fill valve.

Water supply pressure meets requirement: (Permissible range – 30-80 psig (207-550 kPa) Select checkbox, or enter measurement, as appropriate).	<input type="checkbox"/>
Water supply pipe sized correctly: (Minimum 1/2 in (13 mm) diameter required).	<input type="checkbox"/>
Water supply temperature meets requirement: (Optimal range – 34-59 °F (1-15 °C); maximum 77 °F (25 °C)) Select checkbox, or enter measurement, as appropriate).	<input type="checkbox"/>
Water supply piping material: (Materials certified for drinking water systems permitted; plastic or stainless steel only for DI water).	<input type="checkbox"/>
Filter installed close to humidifier: (5 µm – optional, but recommended)	<input type="checkbox"/>
Shutoff valve and union fitting installed:	<input type="checkbox"/>
No pressure surges: (Surge protection device must be installed, if necessary).	<input type="checkbox"/>
All debris flushed from supply line:	<input type="checkbox"/>
No leakages in supply line:	<input type="checkbox"/>

Drainage

Drain pipe (funnel to building drain) diameter meets requirement: (Minimum 1-1/2 in (38 mm) diameter required).	<input type="checkbox"/>
Humidifier drain piping material meets requirement: (Must handle temperatures to 212 °F (100 °C)).	<input type="checkbox"/>
Drain pipe sloped adequately: (Minimum downslope of 1 in/48 in (1.2°) to air gap funnel).	<input type="checkbox"/>
Air gap funnel size meets requirement: (Minimum 2-1/2 in (64 mm) diameter required).	<input type="checkbox"/>
Drain pipe does not touch sides or bottom of air gap funnel:	<input type="checkbox"/>
Air gap funnel location does not permit any rising steam to enter control cabinet:	<input type="checkbox"/>
Air gap funnel located within 3 ft (1 m) from the unit (or according to code):	<input type="checkbox"/>
Drainage rate of building drain meets requirement: (Minimum 2.64 gal/min (10 L/min) for GS 50-300 unit, 5.28 gal/min (20 L/min) for GS 450/600).	<input type="checkbox"/>
Building drain piping material meets requirement: (Only copper or stainless steel permitted; stainless steel only for DI water).	<input type="checkbox"/>

Site Gas Connection

Gas type: (Natural gas or propane)	
Gas supply pressure: (Natural gas permissible range – 5-10 in H2O (1.25-2.49 kPa) Propane permissible range – 9-14 in H2O (2.24-23.49 kPa))	
Manual gas shutoff valve installed: Distance from humidifier: (Manual shutoff valve must be installed per local code).	<input type="checkbox"/>
Union fitting installed in gas line:	<input type="checkbox"/>
Gas supply pipe diameter and connection meet requirements: (Refer to Table 10 on page 21 for details).	<input type="checkbox"/>
Gas supply piping material: (Stainless steel or black pipe permitted)	
Sediment trap installed: (Sediment trap required if black pipe is used for gas line).	<input type="checkbox"/>
Performed leakage test on gas line (up to unit):	<input type="checkbox"/>

Humidifier Mounting

Refer to [Table 11 on page 23](#) and [Table 12 on page 23](#) for required and suggested clearances respectively.

Non-combustible mounting surface? (Withstand temperatures 140-158 °F (60-70 °C))	<input type="checkbox"/>
Unit level?	<input type="checkbox"/>
Front clearance:	
Left side clearance:	
Right side clearance:	
Ground clearance:	
Overhead clearance:	

Steam Line(s)

Steam line diameter and equivalent length meet requirements: (Refer to Table 14 on page 32 for details).	<input type="checkbox"/>
Steam line piping material meets requirement: (Copper (MED Type-L) or stainless steel (minimum DIN 1.4301) required).	<input type="checkbox"/>
Type of insulation:	
Slope of steam line meets requirement: (Minimum constant upslope of 2 in/12 in (10°), or minimum constant downslope of 1/2 in/12 in (2°) required).	<input type="checkbox"/>
Steam line rises straight up minimum 12 in (300 mm) before first bend:	<input type="checkbox"/>
Steam line does not reduce in diameter or merge, except at steam distributor:	<input type="checkbox"/>
No restrictions/kinks in steam line:	<input type="checkbox"/>
Steam line fully supported, with no sags:	<input type="checkbox"/>
All debris flushed from steam line:	<input type="checkbox"/>
Backpressure meets requirement: (Maximum permissible static pressure and backpressure in steam line – 6 in H2O (1.49 kPa) for compact units; or 10 in H2O (2.49 kPa) for full-size units) Duct static pressure: (Enter static pressure (if available), and if positive or negative pressure).	<input type="checkbox"/>

Steam Line Condensate Drains

Note: Make sure all condensate drains meet these requirements.

Slope of all condensate lines meets requirement: (Minimum constant downslope of 1 in/48 in (1.2°) required).	<input type="checkbox"/>
Condensate lines connect to full-size Tee connectors:	<input type="checkbox"/>
Diameter of condensate traps meets requirement: (Minimum 12 in (300 mm) required).	<input type="checkbox"/>
Condensate trap drop meets requirement: (Minimum 12 in (300 mm) below condensate Tee and steam distributor required).	<input type="checkbox"/>
Condensate traps installed at all low points, and horizontal-to-vertical transitions in steam line:	<input type="checkbox"/>
Condensate traps installed at regular intervals on long runs exceeding 15 ft (4.5 m):	<input type="checkbox"/>
Condensate lines have individual traps before emptying into a common drain:	<input type="checkbox"/>
No restrictions/kinks in condensate lines:	<input type="checkbox"/>
All debris flushed from condensate lines:	<input type="checkbox"/>
Condensate cooling installed, (if required by local code):	<input type="checkbox"/>
All condensate traps primed:	<input type="checkbox"/>

Electrical Power Connections

Power supply meets voltage and current requirements shown on specification label:	<input type="checkbox"/>
Dedicated external fused disconnect switch installed to local code: (The maximum current to the unit must not exceed 15 A).	<input type="checkbox"/>
Phase-to-phase voltage measurements:	
All contactor screws torqued properly: (Refer to label on contactor for correct torque value).	<input type="checkbox"/>
Proper grounding: (Green wire must be connected to GND in the supply)	<input type="checkbox"/>
All wiring and connectors fastened securely:	<input type="checkbox"/>

Combustion Air

Space Air Installation	
Combustion air requirements satisfied: (Meet all applicable local and national codes).	<input type="checkbox"/>
Combustion air free of contaminants:	<input type="checkbox"/>
Fresh air intake requirements satisfied: (Refer to Table 16 on page 42 for minimum fresh air cross-sectional area requirements. Refer to local codes).	<input type="checkbox"/>
Elbow installed at intake air inlet: (Required for GS 150-600 units).	<input type="checkbox"/>

Sealed Combustion Installation	
Combustion air requirements satisfied: (Meet all applicable local and national codes).	<input type="checkbox"/>
Intake vent type meets requirement: (ABS, PVC, CPCV or polypropylene vents permitted).	<input type="checkbox"/>
Intake vent length: (Permissible maximum equivalent length – 100 ft (30 m); maximum 50 ft (15 m) for GS 50 using propane).	
Intake vent diameter meets requirement: (Refer to Table 17 on page 43 for vent size).	<input type="checkbox"/>
Intake vent diameter uniform over entire length:	<input type="checkbox"/>
Spacing between air intake and exhaust terminals meets requirement: (Minimum 3 ft (1 m) required. Refer to local codes).	<input type="checkbox"/>
Intake vent joints and seams sealed:	<input type="checkbox"/>
Intake vent supported with hangers or pipe straps:	<input type="checkbox"/>
Intake vent insulated (in cold climates):	<input type="checkbox"/>

Exhaust Venting

Exhaust venting requirements satisfied: (Meet all applicable local and national codes).	<input type="checkbox"/>
Exhaust vent type: (Refer to Table 18 on page 46 for vent types).	
Exhaust vent length: (Permissible maximum equivalent length – 100 ft (30 m). Maximum 50 ft (15 m) for GS 50 using propane).	
Exhaust vent diameter meets requirement: (Refer to Table 18 on page 46 for exhaust vent size).	<input type="checkbox"/>
Exhaust vent diameter uniform over entire length:	<input type="checkbox"/>
Slope of exhaust vent meets requirement: (Minimum constant upslope of 1/2 in/12 in (2°) required).	<input type="checkbox"/>
Exhaust vent insulated on runs over 20 ft (6.1 m):	<input type="checkbox"/>
Exhaust vent joints and seams sealed:	<input type="checkbox"/>
Exhaust vent supported with hangers or pipe straps:	<input type="checkbox"/>
Condensate traps in the exhaust vent (if installed) primed with water:	<input type="checkbox"/>

Controls

Note: If Condair control devices are installed, enter their locations below; otherwise leave fields empty.

Condair humidity controls location:	
Condair high limit switch location: (Minimum 3× absorption distance from the distributor required).	
Condair air proving switch location:	

B.1.2 Performance Checklist

Complete the performance tests after inspecting the site services and the installation, then fill out the form below. **Note:** When filling out the form leave the checkbox un-checked if the item does not apply, or if the requirement is not satisfied. Enter all notes and exceptions in the space provided [on page 89](#).

Preliminary	
Pre-start-up checklist completed:	<input type="checkbox"/>
Gas leakage test inside unit completed:	<input type="checkbox"/>
Check for water leaks inside unit completed:	<input type="checkbox"/>
Condensate trap inside the unit primed: (Nortec GS CS/NX models only).	<input type="checkbox"/>
All access panels installed and fastened securely:	<input type="checkbox"/>

Start-Up	
Shutoff valve in water supply line open:	<input type="checkbox"/>
Fill tests completed successfully:	<input type="checkbox"/>
Ignition safety shutoff test completed successfully:	<input type="checkbox"/>
Manual gas shutoff valve open:	<input type="checkbox"/>
On/Off switch set to the On position:	<input type="checkbox"/>
Software version:	

Distribution System	
Note: For commissioning the distribution system itself, refer to the individual commissioning checklist for the distribution system.	
SAM-e	<input type="checkbox"/>
Mini-SAM-e	<input type="checkbox"/>
Blower Pack	<input type="checkbox"/>
ASD/BSD/CSD	<input type="checkbox"/>
Model:	
Number of XSD units:	
Distance to obstruction: (Minimum 1× absorption distance required from the distributor to first obstruction (coil/bend) downstream).	
Distance to filter: (Minimum distance between the distributor and filter downstream – 1.5-2× absorption distance for class C filter, and 2.5-3× absorption distance for sub-micron particle filter).	

Controls				
Select the type of signal input connected to the channels of the low voltage terminal strip #1: (Enter setpoint value (if applicable) in the field below the checkbox).	Demand Humidistat (modulating)	On/Off Humidistat	Transducer (modulating)	Digital Controls
	CH 1:	<input type="checkbox"/>	<input type="checkbox"/>	<input type="checkbox"/>
	CH 2:	<input type="checkbox"/>	<input type="checkbox"/>	<input type="checkbox"/>
	On/Off:	<input type="checkbox"/>	<input type="checkbox"/>	<input type="checkbox"/>
If a second set of inputs is connected to the channels of the low voltage terminal strip #2 (on dual cylinder units running in independent mode only), select the type of signal input connected to the terminal strip #2: (Enter setpoint value (if applicable) in the field below the checkbox).	Demand Humidistat (modulating)	On/Off Humidistat	Transducer (modulating)	Digital Controls
	CH 1:	<input type="checkbox"/>	<input type="checkbox"/>	<input type="checkbox"/>
	CH 2:	<input type="checkbox"/>	<input type="checkbox"/>	<input type="checkbox"/>
	On/Off:	<input type="checkbox"/>	<input type="checkbox"/>	<input type="checkbox"/>
Control signal configuration in the software matches inputs connected to unit:	<input type="checkbox"/>			

Controls, continued...	
Sensed humidity less than setpoint value (if transducer is used):	<input type="checkbox"/>
Security loop closed: (On a dual cylinder unit running in series or parallel mode, a jumper must be installed between the pins "2" in the two low voltage terminal strips).	<input type="checkbox"/>
Blower pack loop closed:	<input type="checkbox"/>
Humidifier responds to control signal interruption:	<input type="checkbox"/>

Notes

Enter notes and exceptions in the space below.

Notes:			
Commissioned by:		Commissioning Date:	
Company:			

Clear Form

Print Form

Save Form

To print the completed forms (if using an electronic version of the manual), select the **Print Form** button above. In the Print dialog box that appears, select the page numbers under *Pages to Print*, and the **Fit** option under *Page Sizing & Handling*. Click **Print**.

To save the completed electronic forms, first select the **Save Form** button above, and select "Adobe PDF" from the *Printer* drop-down list in the dialog box. Then select the page numbers, and click **Print**. Finally, enter a file name in the dialog box, and click **Save**.



Warranty

Condair Inc. and/or Condair Ltd. (hereinafter collectively referred to as THE COMPANY), warrant for a period of two years after installation or 30 months from manufacturer's ship date, whichever date is earlier, that THE COMPANY's manufactured and assembled products, not otherwise expressly warranted, are free from defects in material and workmanship. No warranty is made against corrosion, deterioration, or suitability of substituted materials used as a result of compliance with government regulations.

THE COMPANY's obligations and liabilities under this warranty are limited to furnishing replacement parts to the customer, F.O.B. THE COMPANY's factory, providing the defective part(s) is returned freight prepaid by the customer. Parts used for repairs are warranted for the balance of the term of the warranty on the original humidifier or 90 days, whichever is longer.

The warranties set forth herein are in lieu of all other warranties expressed or implied by law. No liability whatsoever shall be attached to THE COMPANY until said products have been paid for in full and then said liability shall be limited to the original purchase price for the product. Any further warranty must be in writing, signed by an officer of THE COMPANY.

THE COMPANY's parts or materials that are considered consumables, including but not limited to: cylinders, filters, nozzles, membranes, media, gaskets, O-rings, etc. are NOT covered by the warranty.

THE COMPANY makes no warranty and assumes no liability unless the equipment is installed in strict accordance with a copy of the catalog and installation manual in effect at the date of purchase and by a contractor approved by THE COMPANY to install such equipment.

THE COMPANY makes no warranty and assumes no liability whatsoever for consequential damage or damage resulting directly from misapplication, incorrect sizing or lack of proper maintenance of the equipment.

THE COMPANY makes no warranty and assumes no liability whatsoever for damage resulting from freezing of the humidifier, supply lines, drain lines, or quality of the water used.

THE COMPANY retains the right to change the design, specification and performance criteria of its products without notice or obligation.

THE COMPANY's limited warranty on accessories, not of the companies manufacture, such as controls, humidistats, pumps, etc. is limited to the warranty of the original equipment manufacturer from date of original shipment of humidifier.

Extended Warranty

Extended warranties are available to purchase under the conditions listed above.



A.G.A. 12-94
Gas Fired Humidifier



CGA CR98-004
Gas Fired Humidifier



CONSULTING, SALES AND SERVICE:

U.S.A.
835 Commerce Park Ave
Ogdensburg, NY 1366-2209

CANADA
2740 Fenton Road
Ottawa, ON, K1T 3T7

Tel: 1.866.667.8321
Fax: 613.822.7964

Email: na.info@condair.com
Website: www.condair.com

