



Explorer®

Analytical and Precision Balances



Completely re-imagined from the ground up, the OHAUS Explorer® rises to a whole new level – a product so extraordinary, it's like nothing you've seen before!

The OHAUS Explorer features SmarText™ 2.0, our user-friendly application-based graphical software platform in concert with a redesigned antistatic draftshield, enhanced weighing performance, and a flexible modular display that detaches from the weighing base. Ingeniously striking a balance between cutting-edge technology and functional design, the Explorer delivers accurate performance, that will improve your efficiency in the lab.

Features Include:

- **Intelligent Performance** – All Explorers have newly optimized linearity and repeatability specifications and enhanced vibration filtering for better balance stability. All models also come standard with AutoCal™ automatic internal calibration. These combined enhancements improve accuracy, efficiency, and throughput.
- **Intuitive Operation** – A large color touch-screen display, icon-driven application software that features 14 unique application modes, and an adjustable angle display make Explorer the easiest to use, most advanced balance in its class today.
- **Ingenious Design** – The base and terminal separate for maximum flexibility in any work area. The design also isolates the weighing chamber to enhance stability and speed results. Draftshield models feature an oversized chamber with a new quick remove design, enhanced with a unique anti static system.
- **Practical Features** – Explorer has four user-programmable touch free sensors to minimize cross contamination and button wear. All Explorers meet or exceed the Class I and II accuracy requirements in accordance with the National Institute of Standards and Technology (NIST) Handbook 44 (approval pending).

Explorer® Analytical and Precision Balances

Intelligent PERFORMANCE

Explorer delivers accurate results within seconds, improving operator efficiency, productivity and throughput, with a stabilization time up to 50% faster.

- **Fast stabilization time**
 - Improves operational efficiency
 - Increases throughput
 - Improves productivity
- **Optimized linearity and repeatability specifications**
 - Provides accurate and repeatable results
- **Optimized vibration filtering**
 - Provides balance stability in unstable environments

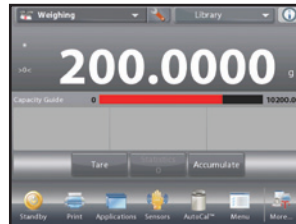

Intuitive SOFTWARE

SmarText™ 2.0 is OHAUS' easy-to-use graphical software featuring 14 applications, QWERTY / numeric keypads, and below-minimum weight indication.

- **Color VGA display with icons for simple menu navigation**
 - High resolution, 5.7 in (145 mm) color TFT display reproduces highly readable operating software
 - Resistive touch screen display quickly responds to operator's touch or stylus
- **14 built-in applications with customization capabilities to meet the varying needs in laboratory and industrial settings**
- **Minimum Weight capability with visual warning feature**
- **QWERTY keyboard and numeric keypad to quickly input GLP and GMP data and other application data**
- **User Manager with administrator capability**
- **Library function to store and recall customized applications**
- **Alternate RS232 command feature adapts the balance to existing data acquisition software**
- **External input for zero, tare or print operations via the external foot switch accessory**
- **Audible and visual feedback for button presses as well as the indication of the check weighing status**

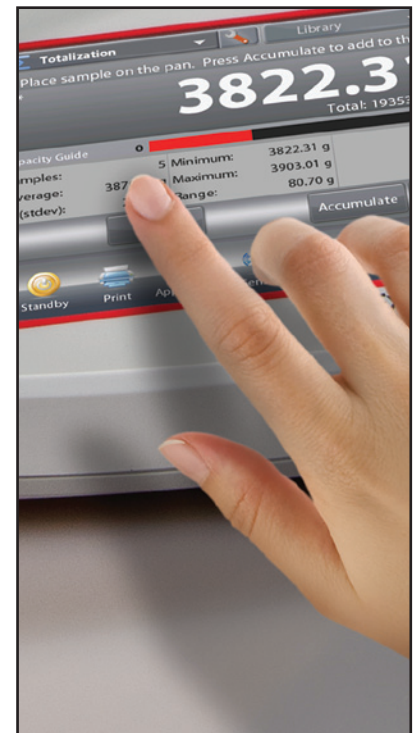

Ingenious DRAFTSHIELD

Explorer's draftshield provides ample access and visibility to the weighing chamber and features antistatic coated glass.

- Frameless, flip-top design provides unobstructed access to the weighing chamber
- The expansive side entry 6.3 x 9.4 in (160 mm x 240 mm) allows you to freely place and remove large weigh boats or other large vessels in the weighing chamber
- Antistatic coated glass helps dissipate static charges in the weighing chamber which could adversely affect the weighing results
- Side doors seamlessly glide on top-mounted bearings helping to prevent any potential bind up when balance is left uncleaned
- Easy to install and remove glass panels and a stainless steel bottom make Explorer extremely easy to clean
- A draftshield chamber light is available when the balance is used in low lighting environments

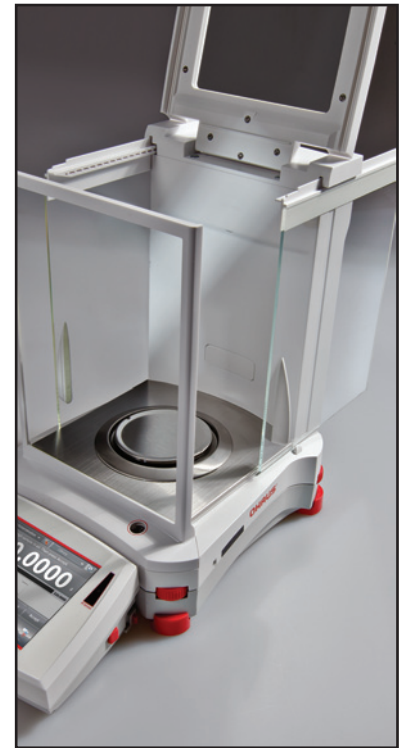

Practical TOUCHLESS SENSORS

Explorer features four touchless sensors for hands-free operation of print, calibration, tare, and other selectable functions

- **Hands-free operation**
 - Improves weighing efficiency
 - Eliminates sample residue transfer
 - Minimizes contamination
- **Two sensors on the base and two on the display** can be set up individually to allow for remote operations



Ingenious MODULAR DESIGN

Explorer's modular design features a color touch display that can be separated from the weighing base

- **Display features:**

- Angular adjustment to optimize viewing
- Easy access communication ports including standard USB and RS232 and an optional third port of either RS232 or Ethernet
- Left and right side cable exit feature for customized installation capability
- Tower and wall mount ready for modular installation
- In-use cover for protection against rugged use
- Extension cable accessory extends remote use up to 10 feet



- **Base features:**

- QuadraStance™ design with four low resistance adjustable thumbwheels make the balance easy to level and provide superior stability
- Robust die-cast metal bottom housing
- Accessory tower mount ready for modular installation
- Cable storage system

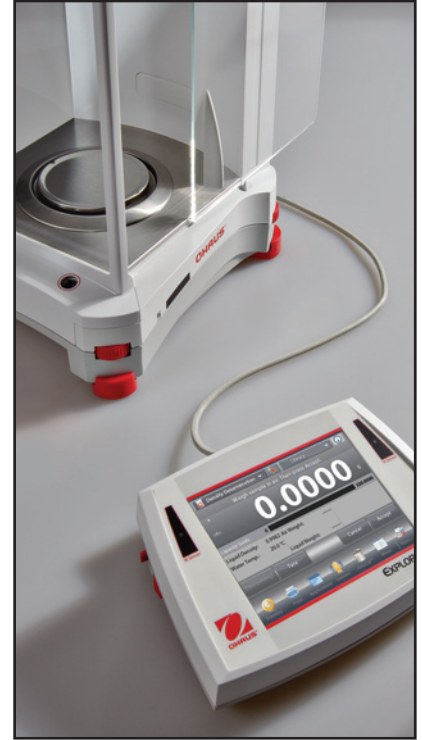

Practical APPROVALS*

Explorer is designed and engineered to meet stringent NTEP requirements for use in legal applications such as pharmacies, jewelry stores and retail outlets

The Explorer has been designed to meet or exceed the Class I and II accuracy requirements in accordance with the National Institute of Standards and Technology (NIST) Handbook 44.

In addition to being designed to meet or exceed the Class I and II accuracy requirements for a prescription balance, the Explorer will also be approved for Counting for Prescription Filling. Explorer will make it easy to comply with the regulations requiring that an approved balance to be installed in every operating pharmacy.



*Approval pending

Other Standard Features & Equipment

Menu lock switch, security bracket, integral weigh below hook for below balance weighing applications, removable stainless steel weighing platform, stability indicator, overload and underload indicators, auto standby, powered by an ENERGY STAR® qualified adapter for a better environment.

Accessories

	OHAUS Number
Tower Mount for Display	83021102
Display Extension Cable	83021083
Density Determination Kit	80253384
Draftshield Kit (0.01g and 0.1g balances)	83021084
Security Device	76288-01
Interface Cable, USB (Type A to B)	83021085
Second RS232 Kit	83021081
Ethernet Kit	83021082
Foot Switch Kit	83021086
Compact Thermal Printer	80251992
Compact Dot Matrix Impact Printer	80252042
RS232 Cable & Adapter to 80252042 Printer	80252571
RS232 Cable & Adapter to 80251992 Printer	80252581
RS232 Cable, PC 25 Pin.....	80500524
RS232 Cable, PC 9 Pin.....	80500525



Optional Tower Mount

Outline Dimensions

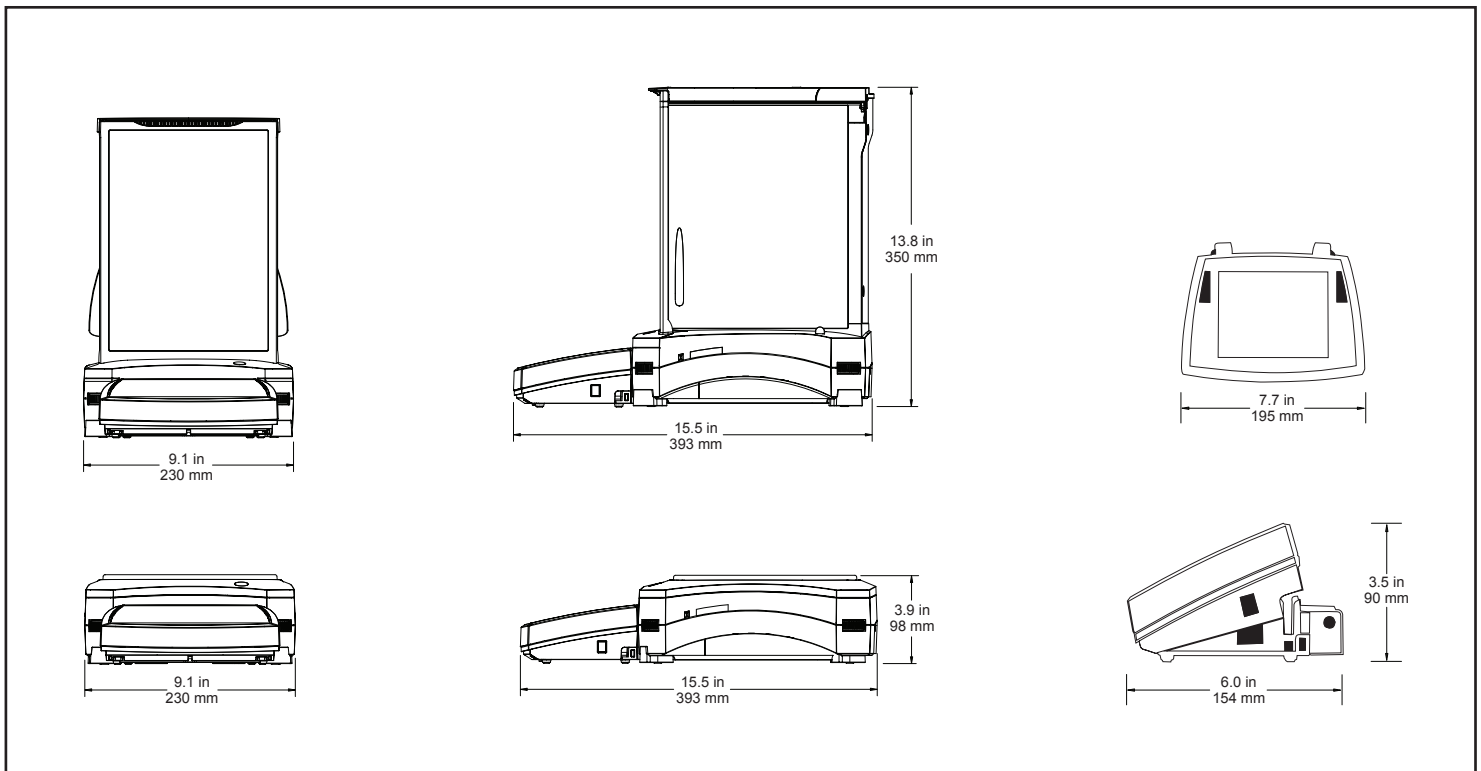

Explorer[®] Analytical and Precision Balances

Specifications

Model	EX124	EX224	EX324	EX223	EX423	EX623	EX1103	EX2202	EX4202	EX6202	EX10202	EX6201	EX10201
Capacity (g)	120	220	320	220	420	620	1100	2200	4200	6200	10200	6200	10200
Readability (g)	0.0001			0.001			0.01			0.1			
Repeatability std (g)	±0.0001			±0.001			±0.01			±0.1			
Linearity (g)	±0.0002			±0.002			±0.02			±0.1			
Stabilization Time (sec)	≤2	≤3	≤1.5				≤1						
Weighing Applications	Weighing, Percent Weighing, Parts Counting, Check Weighing, Dynamic/Animal Weighing, Filling, Totalization, Formulation, Differential Weighing, Density Determination, Peak Hold, Ingredient Costing, Pipette Adjustment, SQC												
Weighing Units	Gram, Milligram, Kilogram, Carat, Ounce, Ounce Troy, Pound, Pennyweight, Grain, Newton, Momme, Mesghal, Hong Kong Tael, Singapore Tael, Taiwan Tael, Tical, Tola, Baht, 3 Custom Units												
Calibration	AutoCal™ on Δ1.5°C temperature change, 11 hours, and external calibration												
Tare Range	To capacity by subtraction												
Power Requirements	AC Adapter Input: 100-240 VAC 0.6A 50-60 Hz												
Display Type	Full-color VGA graphic display, 4-wire resistive touch screen												
Display Size	5.7 in / 145 mm (diagonal)												
Display Housing Dimensions (W x H x D)	7.7 x 3.5 x 6.0 in / 195 x 90 x 154 mm												
Base Housing Dimensions (W x H x D)	9.1 x 13.8 x 15.5 in / 230 x 350 x 393 mm						9.1 x 3.9 x 15.5 in / 230 x 98 x 393 mm						
Communication	RS232, USB												
Operating Temperature Range	50°F (10°C) to 86°F (30°C)												
Operating Humidity Range	15% to 80% at 87.8°F (31°C) decreasing linearly to 50% at 40°C, non-condensing												
Storage Conditions	-14°F (-10°C) to 140°F (60°C) at 10% to 90% relative humidity, non-condensing												
Pan Size	Ø 3.5 in / 90 mm			Ø 5.1 in / 130 mm				7.5 x 7.9 in / 190 x 200 mm					
Net Weight	15.2 lb / 6.9 kg						9.5 lb / 4.3 kg			11 lb / 5 kg			
Shipping Weight	21.1 lb / 9.6 kg						15 lb / 6.8 kg			16.3 lb / 7.4 kg			
Shipping Dimensions	21 x 15 x 21 in / 55 x 38.5 x 55.1 cm						21 x 15 x 12 in / 55 x 38.5 x 29.1 cm						

Compliance

- This product conforms to the EMC Directive 2004/108/EC, the Low Voltage Directive 2006/95/EC and the Non-automatic Weighing Instruments Directive 2009/23/EC. The complete Declaration of Conformity is available online at www.ohaus.com.
- This equipment has been tested and found to comply with the limits for a Class A digital device, pursuant to Part 15 of the FCC Rules.
- Quality:** All OHAUS Explorer[®] balances are manufactured under an ISO 9001:2008 Registered Quality Management System. Our rugged construction and stringent quality control have been hallmarks of all OHAUS products for over a century.

Authorized Ohaus Dealer
 Graintec Scientific
www.graintec.com.au
 1300-640-299

OHAUS CORPORATION

* 7 Campus Drive
 Suite 310
 Parsippany, NJ 07054 USA
 Tel: 800.672.7722
 973.377.9000
 Fax: 973.944.7177

www.ohaus.com

*With offices throughout Europe,
 Asia, and Latin America*

* ISO 9001
 Registered Quality Management System

