

super
20 slings inc.
YEARS of

Secure Solutions

HOOKS & LINKS



Shackles & Turnbuckles	Chain Slings	Wire Rope Slings	Synthetic Chain Slings	Round Slings	Web Slings	Sling Protection		
Hooks & Links	Lifting Points	Hoists & Blocks	Lifting Devices	Pipe & Hose Restraints	Tie Down Assemblies	Tie Down Accessories	Towing & Recovery	Rope & Cordage

ASME B30.10 Hook

Inspection Criteria and Best Practices for Use

A look at the ASME B30.10 Hooks standard and what you need to know about the inspection and use of your hooks.

ASME B30.10 Chapter 10-1

This chapter specifically refers to all hooks that support the load in the base (bowl, saddle, or pinhole) of the hook. This includes all of the following types of load-bearing hooks:

- Clevis Hook (with or without latch)
- Eye Hook (with or without latch)
- Shank Hook (with or without latch)
- Duplex Hook—also known as a “Sister Hook” (with or without latches)
- Articulated Duplex Hook (with or without latches)
- Quad Hook (with or with latches)
- Single Plate Hooks and Laminated Plate Hooks

ASME B30.10 Chapter 10-2

This chapter specifically refers to all hooks that do not support a load in a direct-pull configuration, such as:

- Grab hooks,
- Foundry hooks
- Sorting hooks
- Choker hooks

Chapter 10-1 and Chapter 10-2 may have different information related to the materials and components, proof testing, fabrication and configurations, and repair and modification requirements—depending on if you're using load-bearing hooks, or hooks that don't support the load in a direct-pull configuration. Our recommendation is to obtain a copy of the most recent edition of ASME B30.10 - Hooks and review to make sure your hooks are being used, inspected, and maintained in accordance with industry standards.

Hook Identification Requirements

ASME B30.10 requires the manufacturer's identification and rated load identification be forged, cast, or die stamped on a low-stress and non-wearing area of the hook. If the hook is used in conjunction with equipment described in other B30 standards, such as on a sling assembly, or as part of a below-the-hook lifting device, the equipment manufacturer's identification and rated load identification shall be forged, cast, or die stamped on a low-stress and non-wearing area of the hook.



How Often Do You Need to Inspect Your Hooks?

Similar to sling inspections, all hook inspections shall be performed by a Designated Person with any deficiencies further examined and determination made by a Qualified Person as to whether they constitute a hazard.

For hooks in regular service, inspection procedures and record keeping requirements are governed by the kind of equipment in which they are used. If there are more stringent inspection requirements for hooks as stated in standards for specific equipment, those inspection requirements take precedence over the requirements listed below:

Initial Inspection

Prior to use, all new, altered, modified, or repaired hooks shall be inspected to verify compliance with the applicable ASME B30.10 Hooks standard. Written records of initial inspections are NOT required.

Frequent Inspection

Frequent inspections include observations of the hook being used during operation, as well as visual inspections to identify any conditions or removal criteria outlined in ASME B30.10. For semi-permanent and inaccessible locations where frequent inspections are not feasible, a Qualified Person will determine the frequency of periodic inspection requirements to satisfy ASME B30.10 requirements. Inspection intervals should be based on:

- The frequency of hook use
- Severity of service conditions
- Nature of load-handling activities
- Experience gained on the service life of hooks used in similar circumstances

Guidelines for frequent inspection intervals:

Normal Service – Monthly
 Heavy Service – Weekly to Monthly
 Severe Service – Daily to Weekly
 Conditions listed under Removal Criteria, or any other condition that may result in a hazard, shall cause the hook to be removed from service. Hooks shall not be returned to service until approved by a Qualified Person. Written records of frequent inspections are NOT required.



- Sling Protection
- Web Slings
- Round Slings
- Synthetic Chain Slings
- Wire Rope Slings
- Chain Slings
- Shackles & Turnbuckles
- Hooks & Links**
- Lifting Points
- Hoists & Blocks
- Lifting Devices
- Pipe & Hose Restraints
- The Down Assemblies
- The Down Accessories
- Towing & Recovery
- Rope & Cordage

Periodic Inspection

A complete and thorough inspection of the hook shall be performed. Disassembly of the hook may be required to perform a complete examination and identify conditions based on the removal criteria outlined in ASME B30.10. Periodic inspections shall be performed at a minimum interval of 12 months, unless approved by a Qualified Person. Periodic rigging inspection intervals should be based on:

- Frequency of hook use
- Severity of service conditions
- Nature of load-handling activities
- Experience gained on the service life of hooks used in similar circumstances

Guidelines for periodic inspection intervals:

- Normal Service – Yearly with equipment in place
 - Heavy Service – Semi-annually, with equipment in place unless external conditions indicate that disassembly should be done to permit detailed inspection monthly to quarterly
 - Severe Service – Quarterly, as in heavy service, except that the detailed inspection may show the need for a non-destructive type of testing
- Hooks shall not be returned to service until approved by a Qualified Person. Written records of periodic inspections ARE required.

ASME B30.10 Inspection Criteria for Hooks

The goal of a rigging inspection is to thoroughly evaluate the condition and remaining strength of all equipment used to perform overhead lifts or used for load-handling activities.

Hooks shall be removed from service if damage or evidence of any of the following is present. A hook may not be returned to service until it has been approved by a Qualified Person.

Removal Criteria:

- Missing or illegible hook manufacturer's identification or secondary manufacturer's identification
- Missing or illegible rated load identification
- Excessive pitting or corrosion
- Cracks, nicks, or gouges
- Wear—any wear exceeding 10% (or as recommended by the manufacturer) of the original section dimension of the hook or its load pin
- Deformation—any visible apparent bend or twist from the plane of the unbent hook
- Throat opening—any distortion causing an increase in throat opening of 5% not to exceed 1/4" (6mm), or as recommended by the manufacturer
- Inability to lock—any self-locking hook that does not lock
- Inoperative latch (if provided)—any damaged latch or

- malfunctioning latch that not close the hook's throat
- Damaged, missing, or malfunctioning hook attachment and securing means
- Thread wear, damage, or corrosion
- Evidence of heat exposure or unauthorized welding
- Evidence of unauthorized alterations such as drilling, machining, grinding, or other modifications

Best Operating Practices When Using Hooks

Utilize best practices when using, inspecting, and storing your hooks. Make sure all of your rigging equipment has the proper markings/identification, is in acceptable working condition and passes a visual inspection, and is stored in an area where it's not susceptible to extreme temperatures, excess moisture, chemical exposure, or mechanical damage.

Operators or riggers using hooks shall be aware of the following:

Extreme Temperatures

Consult with the manufacturer or a Qualified Person if you are planning to use a hook in an environment where temperatures exceed 400°F (204°C) or -40°F (-40°C).

Chemically Active Environments

The strength of hooks can be affected by chemically active environments, such as caustic or acid substances or fumes. The hook manufacturer or a Qualified Person should be consulted before hooks are used in chemically active environments.

Use of Latches on Hooks

We advise that the end user must evaluate the work activity with regards to the safety of their employees. If the activity makes the use of the latch impractical, unnecessary, or more dangerous, then the end user may choose to eliminate the latch. It is also recommended that each lifting activity is considered independently as far as the use of a hook latch is concerned.

Super Slings recommends that hook latches should be used.

- Any hook that is designed to have a latch, should have the latch installed
- New slings are sold with the latch installed unless the customer requests no latch
- If customers make an inquiry about the use of a latch on a hook, we may recommend for them to consider OH&S, among them the following:

Safety latches

303(1) An employer must ensure that a hook has a safety latch, mousing or shackle if the hook could cause injury if it is dislodged while in use.

303(2) Despite subsection (1), if a competent worker disconnecting the hook would be in danger if the hook has a safety latch, mousing or shackle, the employer may use another type of hook.

Alberta Occupational Health and Safety Code 2009



Safe Use

- Never load in excess of the rated capacity for the application.
- Keep a record of all slings in use.
- User should remove all twists from a chain leg before lifting and, should never knot a chain.
- Always use YOKE shortening hook or clutch when chain slings should be shortened.
- Always inspect to insure that chain is free from damage or wear before use.
- Always inspect all sling components prior to each use.
- Ensure that chain is protected from any sharp corners on the load.
- Ensure that the master link articulates freely on the hook of the crane or other lifting appliance.
- Never tip load hooks. The load should always be supported correctly in the bowl of the hook.
- Always use the correct size sling for the load, allowing for the included angle and the possibility of unequal loading.
- Personnel must keep all body parts from between the sling and the load, and from between the sling and the crane/ hoist hook. Persons shall never ride the chain sling/rope sling or web sling or the load during lifting or while suspended.
- Persons must stand clear of all loads while lifting or while suspended. During lifting, with or without the load, personnel must be alert for possible snagging of the load or the chain sling.

MAINTENANCE

- A thorough examination should be carried out by a competent person at intervals at least every year or more frequently according to statutory regulations, type of use and past records.
- Chains with bent links or with cracks or gouges in the link should be replaced, as should deformed components such as bent master links, deformed hooks and any fittings showing signs of damage.
- Chain and components wear should never exceed 10% of the original dimensions.
- Once a chain sling has been overloaded it must be taken out of service.
- Store chain slings on a properly designed rack. They should not be left lying on the floor where they may suffer mechanical or corrosion damage or may be lost.

LIMITATION ON USE

- YOKE alloy chain or chain slings should not be used in acid or caustic solutions nor in heavily acidic or caustic laden atmospheres. The high tensile strength of the heat treated alloy material in alloy steel chains and components is susceptible to hydrogen embrittlement when exposed to acids.
- YOKE slings must not be heat-treated, galvanized, plated, coated or subject to any process involving heating or pickling. Each of these processes can have dangerous effects and will invalidate the manufacturer certificate.
- YOKE slings may be used at temperatures between -40°C to 200°C with no reduction in the working load limit. The use of YOKE chain slings within the permissible temperature range in the table below does not require any permanent reduction in working load limit when the chain sling is returned to normal temperatures. A sling accidentally exposed to temperatures in excess of the maximum permissible should be withdrawn from service immediately and returned to the distributor for thorough examination.
- When using YOKE slings in exceptionally hazardous conditions, the degree of hazard should be assessed by a competent person and the Working Load Limit adjusted accordingly. Examples are lifting of potentially dangerous loads such as molten metals, corrosive materials or fissile material and including certain offshore activities.

Sling temperature (F)	Sling temperature (°C)	Reduction in Working Load Limit
-40 ° to 400	-40 to 200°	None
400° to 550°	200° to 300°	10%
550° to 750°	300° to 400°	25%
Above 750	Above 400°	Do not use.

Quality Management System:



Q1 0467



QMS 0726



Sling Protection
Web Slings
Round Slings
Synthetic Chain Slings
Wire Rope Slings
Chain Slings
Shackles & Turnbuckles
Hooks & Links
Lifting Points
Hoists & Blocks
Lifting Devices
Pipe & Hose Restraints
The Down Assemblies
The Down Accessories
Towing & Recovery
Rope & Cordage

Lift it up, Tie it down, Pull it around



Safety is our first priority™



Hook & Attachment Use Limitations Incorrect Use Examples

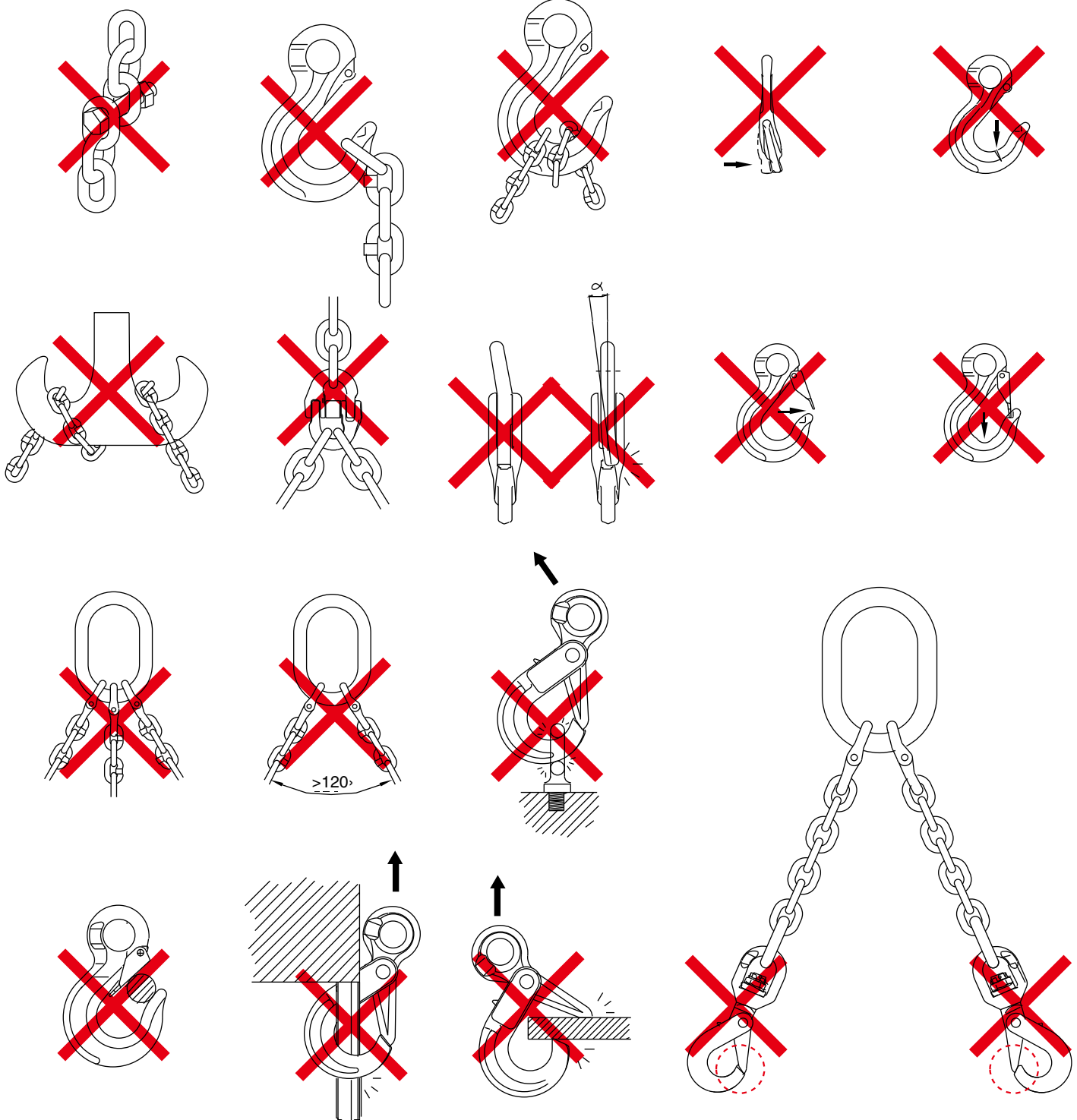

Sling Protection
Web Slings
Round Slings
Synthetic Chain Slings
Wire Rope Slings
Chain Slings
Shackles & Turnbuckles
Hooks & Links
Lifting Points
Hoists & Blocks
Lifting Devices
Pipe & Hose Restraints
Tie Down Assemblies
Tie Down Accessories
Towing & Recovery
Rope & Cordage

X-027 G-100 Self-Locking Swivel Hook

G-100 Eye Self Locking Hook

Product details



Safety is our first priority™

Application

- Quenched and Tempered Alloy Steel.
- At least 25% greater WLL than traditional G80 products.
- Manufactured in accordance with EN 1677- 3 and ASME B30.26, ASME B30.10.
- Certified by DGUV GS-OA-15-05 & DGUV GS-MO-15-05
- Proof Load tested at 2.5 times the WLL with certification for each batch manufactured.
- Design Factor 4:1, Fatigue rated to 20,000 cycles at 1.5 times the WLL.
- Tempering temperature minimum 400°C
- Magnaflux crack detection is performed 100% on each batch.



8-P025
For most sizes



8-P025T
For 26mm

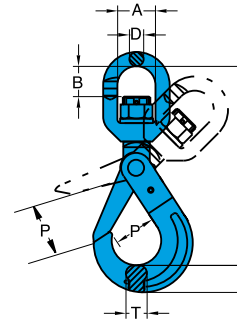

Item Code	WLL [lbs]		Chain Size	Dimensions [in]							Net Weight
	4:1	5:1		[in]	A	B	D	H	K	P	
X-027-06	3,200	2,600	7/32	1.26	0.87	0.47	0.75	5.87	1.10	0.59	1.54
X-027-07	5,700	4,600	9/32-5/16	1.42	1.14	0.51	0.94	7.32	1.34	0.79	2.65
X-027-10	8,800	7,000	3/8	1.61	1.34	0.63	1.18	8.58	1.73	1.02	4.41
X-027-13	15,000	12,000	1/2	1.81	1.69	0.83	1.54	10.87	2.01	1.18	9.04
X-027-16	22,600	18,100	5/8	2.40	1.97	0.91	1.93	12.95	2.36	1.42	15.87
X-027-20	35,300	28,200	3/4	2.91	3.23	0.98	2.56	15.24	2.76	2.09	28.66
X-027-22	42,700	34,200	7/8	3.82	3.74	1.30	2.48	17.99	3.15	1.93	44.09
X-027-26	59,700	47,800	1	4.84	4.53	2.05	2.72	21.06	3.90	2.20	72.75

X-027N G-100 Self-Locking Swivel Hook w/ Bearing

G-100 Eye Self Locking Hook

Product details



Safety is our first priority™

Application

- Quenched and Tempered Alloy Steel.
- At least 25% greater WLL than traditional G80 products.
- Manufactured in accordance with EN 1677- 3 and ASME B30.26, ASME B30.10. PAS1061.
- Certified by DGUV GS-OA-15-05 & DGUV GS-MO-15-05
- Proof Load tested at 2.5 times the WLL with certification for each batch manufactured.
- Design Factor 4:1, Fatigue rated to 20,000 cycles at 1.5 times the WLL.
- Tempering temperature minimum 400°C
- Magnaflux crack detection is performed 100% on each batch.
- Built with ball bearing and enables full swivel feature under load.



8-P025T
For 26mm

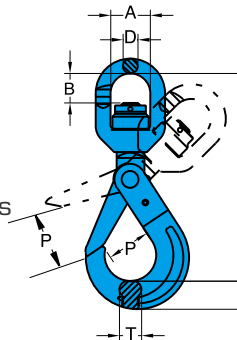

Special Order

Item Code	WLL [lbs]		Chain Size	Dimensions [in]							Net Weight
	4:1	5:1		[in]	A	B	D	H	K	P	
X-027N-06	3,200	2,600	7/32	1.26	0.87	0.47	0.75	5.87	1.10	0.59	1.54
X-027N-07	5,700	4,600	9/32-5/16	1.42	1.14	0.51	0.94	7.32	1.34	0.79	2.87
X-027N-10	8,800	7,000	3/8	1.61	1.34	0.63	1.18	8.58	1.73	1.02	4.41
X-027N-13	15,000	12,000	1/2	1.81	1.69	0.83	1.54	10.87	2.01	1.18	9.48
X-027N-16	22,600	18,100	5/8	2.40	1.97	0.91	1.93	12.95	2.36	1.42	16.09
X-027N-20	35,300	28,200	3/4	2.91	3.23	0.98	2.56	15.24	2.76	2.09	28.66
X-027N-22	42,700	34,200	7/8	3.82	3.74	1.30	2.48	17.99	3.15	1.93	44.09
X-027N-26	59,700	47,800	1	4.84	4.53	2.05	2.72	21.06	3.90	2.20	72.09

Sling Protection
Web Slings
Round Slings
Synthetic Chain Slings
Wire Rope Slings
Chain Slings
Shackles & Turnbuckles
Hooks & Links
Lifting Points
Hoists & Blocks
Lifting Devices
Pipe & Hose Restraints
The Down Assemblies
The Down Accessories
Towing & Recovery
Rope & Cordage

X-950 G-100 Eye Grip Safe Locking Hook

G-100 Eye Self Locking Hook

Product details



Safety is our first priority™



8-P950

For push lock replacement

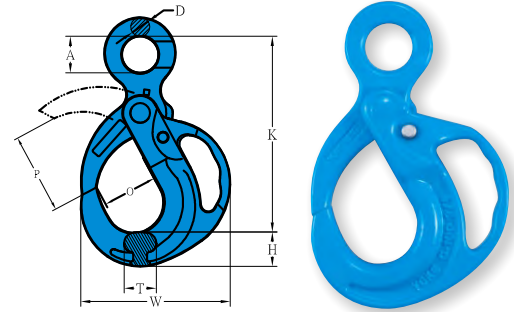

Application

- Quenched and Tempered Alloy Steel.
- Manufactured in accordance with EN 1677- 1.
- Manufactured in accordance with ASTM A952/A952M, DIN PAS 1061.
- Proof Load tested at 2.5 times the WLL with certification for each batch manufactured.
- Design Factor 4:1.
- Fatigue rated to 20,000 cycles at 1.5 times the WLL.
- Tempering temperature minimum 400°C
- Magnaflux crack detection is performed 100% on each batch.

Special Order

Item Code	WLL (lbs)		Chain Size	Dimensions (in)								Net Weight
	4:1	5:1		[in]	A	D	H	K	O	P	T	
X-950-10	8,800	7,000	3/8	1.26	0.51	1.22	6.89	1.93	2.80	1.06	5.47	4.19
X-950-13	15,000	12,000	1/2	1.57	0.63	1.54	8.94	2.24	3.15	1.34	6.85	6.61
X-950-16	22,600	18,100	5/8	1.97	0.83	1.85	10.91	3.07	4.49	1.54	8.35	13.89
X-950-20	35,300	28,200	3/4	2.36	0.91	2.20	12.95	3.58	5.00	2.13	9.84	25.79
X-950-22	42,700	34,200	7/8	2.76	0.94	2.32	13.78	4.13	5.94	2.20	10.24	31.97

X-950 G-100 Swivel Grip Safe Locking Hook

G-100 Swivel Self Locking Hook

Product details



Safety is our first priority™



8-P950

For push lock replacement

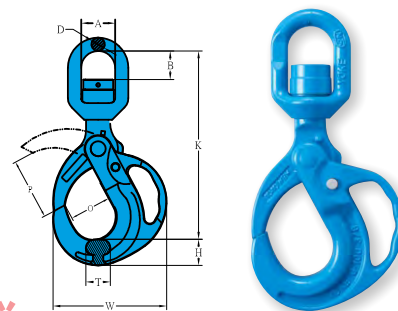

Application

- Quenched and Tempered Alloy Steel.
- Manufactured in accordance with EN 1677- 1.
- Manufactured in accordance with ASTM A952/A952M, DIN PAS 1061.
- Proof Load tested at 2.5 times the WLL with certification for each batch manufactured.
- Design Factor 4:1.
- Fatigue rated to 20,000 cycles at 1.5 times the WLL.
- Tempering temperature minimum 400°C
- Magnaflux crack detection is performed 100% on each batch.
- Built with ball bearing and enables full swivel feature under load.

Special Order

Item Code	WLL (lbs)		Chain Size	Dimensions (in)								Net Weight	
	4:1	5:1		[in]	A	B	D	H	K	O	P		T
X-952N-10	8,800	7,000	3/8	1.61	1.34	0.63	1.22	8.86	1.93	2.80	1.06	5.47	5.29
X-952N-13	15,000	12,000	1/2	1.81	1.73	0.83	1.54	11.22	2.24	3.15	1.34	6.85	11.46
X-952N-16	22,600	18,100	5/8	2.40	1.97	0.91	1.85	13.58	3.07	4.49	1.54	8.35	18.52
X-952N-20	35,300	28,200	3/4	2.91	3.23	0.98	2.20	17.05	3.58	5.00	2.13	9.84	31.97
X-952N-22	42,700	34,200	7/8	3.82	3.74	1.30	2.32	18.70	4.13	5.94	2.20	10.24	43.87

X-025 G-100 Eye Self Locking Hook

G-100 Eye Foundry Hook

Product details



Safety is our first priority™



8-P025T

For trigger

Application

- Quenched and Tempered Alloy Steel.
- At least 25% greater WLL than traditional G80 products. Manufactured in accordance with EN 1677- 3 and ASME B30.26, ASME B30.10, PAS1061.
- Certified by DGUV GS-OA-15-05 & DGUV GS-MO-15-05.
- Proof Load tested at 2.5 times the WLL with certification for each batch manufactured.
- Design Factor 4:1.
- Fatigue rated to 20,000 cycles at 1.5 times the WLL.
- Tempering temperature minimum 400°C
- Magnaflux crack detection is performed 100% on each batch.

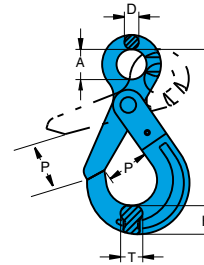

Item Code	WLL (lbs)		Chain Size	Dimensions (in)						Net Weight
	4:1	5:1		(in)	A	D	H	K	P	
X-025-06	3,200	2,600	7/32	0.83	0.39	0.75	4.33	1.10	0.59	1.10
X-025-07	5,700	4,600	9/32-5/16	0.98	0.43	0.94	5.35	1.34	0.79	1.76
X-025-10	8,800	7,000	3/8	1.26	0.51	1.18	6.57	1.73	1.02	3.31
X-025-13	15,000	12,000	1/2	1.57	0.63	1.54	8.15	2.01	1.18	6.61
X-025-16	22,600	18,100	5/8	1.97	0.83	1.93	9.92	2.36	1.42	12.79
X-025-20	35,300	28,200	3/4	2.36	0.91	2.56	11.42	2.76	2.09	22.05
X-025-22	42,700	34,200	7/8	2.76	0.94	2.48	12.56	3.15	1.93	27.56
X-025-26	59,700	47,800	1	3.15	0.98	2.72	13.50	3.90	2.20	33.07

X-047 G-100 Eye Foundry Hook

G-100 Eye Foundry Hook

Product details



Safety is our first priority™

Application

- Quenched and Tempered Alloy Steel.
- At least 25% greater WLL than traditional G80 products.
- Manufactured in accordance with DIN PAS 1061 and ASTM A952/A 952M, EN 1677- 1,
- Proof Load tested at 2.5 times the WLL with certification for each batch manufactured.
- Design Factor 4:1.
- Fatigue rated to 20,000 cycles at 1.5 times the WLL.
- Tempering temperature minimum 400°C
- Not used for general chain sling applications, rather for use where a large throat opening is necessary.
- Before using the hook, check whether hooks without safety latches are allowed to be used for the particular application.

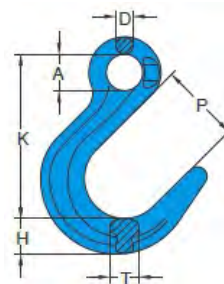

Item Code	WLL (lbs)		Chain Size	Dimensions (in)						Net Weight
	4:1	5:1		(in)	A	D	H	K	P	
X-047-07	5,700	4,600	9/32-5/16	0.94	0.47	1.06	4.84	2.44	0.75	1.76
X-047-10	8,800	7,000	3/8	1.26	0.59	1.26	5.87	2.91	0.91	3.53
X-047-13	15,000	12,000	1/2	1.57	0.75	1.54	7.09	3.46	1.26	5.73
X-047-16	22,600	18,100	5/8	1.97	0.98	1.85	8.39	3.86	1.61	9.92
X-047-20	35,300	28,200	3/4	2.36	1.02	2.24	9.76	4.45	1.81	20.50

Sling Protection
Web Slings
Round Slings
Synthetic Chain Slings
Wire Rope Slings
Chain Slings
Shackles & Turnbuckles
Hooks & Links
Lifting Points
Hoists & Blocks
Lifting Devices
Pipe & Hose Restraints
Tie Down Assemblies
Tie Down Accessories
Towing & Recovery
Rope & Cordage

Eye Hoist Hooks

Eye Type Hoist Hook

Product details

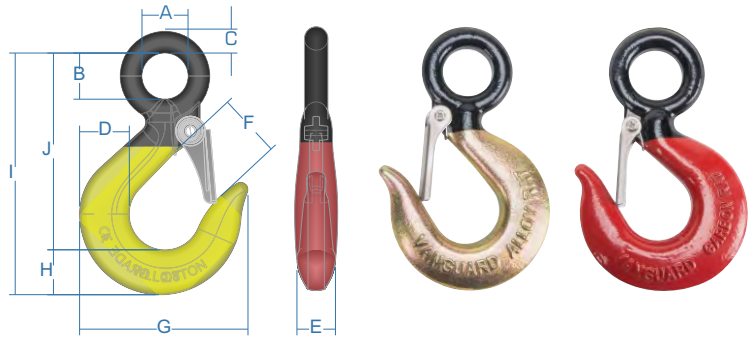

Application

- Forged Carbon or Alloy Steel, quenched & tempered
- Embossed Working Load Limit (WLL) with 5:1 safety factor
- Colour coding prevents mix-ups
- Carbon Steel - black eye, red body
- Alloy Steel - black eye, gold body

Item Code		WLL (lbs)		Dimensions (in)										Net Weight
Carbon	Alloy	Carbon	Alloy	A	B	C	D	E	F	G	H	I	J	lbs
1022205	-	0.50	-	0.56	0.62	0.35	0.75	0.53	0.76	2.55	0.75	3.83	2.75	0.38
1022216	1022380	0.75	1.00	1.50	0.75	0.38	0.88	0.63	0.94	2.88	0.75	4.38	3.25	0.50
1022227	1022391	1.00	1.50	1.75	0.88	0.44	1.00	0.69	1.06	3.13	0.81	4.88	3.63	0.80
1022238	1022402	1.50	2.00	2.00	1.13	0.50	1.19	0.81	1.12	3.50	1.00	5.50	4.13	1.10
1022246	1022413	2.00	3.00	2.38	1.25	0.59	1.38	0.94	1.22	3.94	1.19	6.31	4.56	1.70
1022260	1022424	3.00	4.50	3.00	1.56	0.69	1.63	1.19	1.50	5.00	1.50	7.94	5.75	3.60
1022271	1022435	5.00	7.00	3.81	2.00	0.88	2.06	1.50	1.88	6.25	1.75	10.00	7.38	7.00
1022277	1022446	7.50	11.00	4.70	2.43	1.19	2.53	1.68	2.23	7.25	2.37	12.25	9.00	13.27

Swivel Eye Hoist Hooks

Swivel Eye Type Hoist Hook

Product details

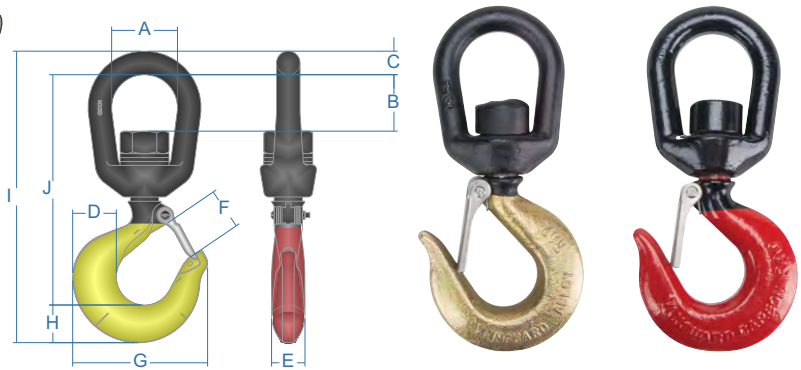

Application

- Forged Carbon or Alloy Steel, quenched & tempered
- Embossed Working Load Limit (WLL) with:
5:1 safety factor for Carbon hooks
4.5:1 safety factor for Alloy hooks

Item Code		WLL (lbs)		Dimensions (in)										Net Weight
Carbon	Alloy	Carbon	Alloy	A	B	C	D	E	F	G	H	I	J	lbs
1048603	1048807	0.75	1.00	1.23	0.92	0.40	0.83	0.60	0.98	2.95	0.86	5.50	4.35	0.55
1048612	1048816	1.00	1.50	1.50	1.35	0.52	0.94	0.66	1.07	3.33	0.86	6.50	5.23	0.75
1048621	1048825	1.50	2.00	1.73	1.70	0.64	1.13	0.75	1.10	3.75	1.04	7.50	6.00	1.25
1048630	1048834	2.00	3.00	1.70	1.60	0.64	1.36	0.87	1.21	4.25	1.20	8.00	6.25	1.70
1048639	1048840	3.00	4.50	1.95	1.84	0.78	1.66	1.11	1.52	5.00	1.55	9.50	7.50	3.60
1048648	1048859	5.00	7.00	2.42	2.42	1.02	2.10	1.35	2.04	7.00	1.99	11.75	9.75	7.08
1048657	1048868	7.50	11.00	2.70	2.51	1.10	2.65	1.75	2.40	8.00	2.45	14.50	11.12	13.00
1048666	1048880	10.00	15.00	4.10	3.76	1.50	3.50	2.69	3.41	10.34	3.00	21.34	16.71	22.00
1048675	1048889	15.00	22.00	4.10	3.76	1.50	4.63	3.00	4.00	13.62	3.61	23.25	18.01	41.00

Stainless Latch Kits (FOR HOIST HOOKS)

Item No.	Carbon	Alloy	Item No.	Carbon	Alloy
75-1090027	3/4	1	75-1090081	3	4-1/2
75-1090045	1	1-1/2	75-1090107	5	7
75-1090063	1-1/2	2	75-1090125	7-1/2	11
75-1090075	2	3	75-1090126	11	15



8-073 Container Hook. Code "KL"

Container Lifting Eye Hook

Product details



Application

- Specifically designed for use with container fittings
- Container Hooks shall always be used with a spreader, either a 2 point spreader bar or a 4 point spreader.
- We recommend that you use a spreader and lift from the bottom when the container is loaded as this is where the container is strongest

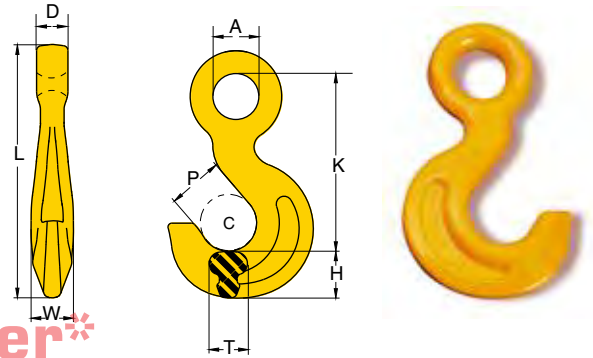

Special Order

Item Code	WLL (lbs)		Chain Size *Gr. 80 [in]	Dimensions [in]									Net Weight Lbs
	4:1	5:1		A	C	D	H	K	L	P	T	W	
8-073-16	22,600	18,100	5/8	1.93	2.37	1.26	1.97	7.44	10.31	2.28	1.61	1.73	8.16

8-067 Eye Container Hook Code "KA"

Container Lifting Eye Hook

Product details



Application

- Specifically designed for use with container fittings
- Container Hooks shall always be used with a spreader, either a 2 point spreader bar or a 4 point spreader.»
- Available as a straight and turned 45 degrees. To avoid the risk of disengagement during use, a tolerance of +- 15 degrees from nominal should be adhered to.
- We recommend that you use a spreader and lift from the bottom when the container is loaded as this is where the container is strongest

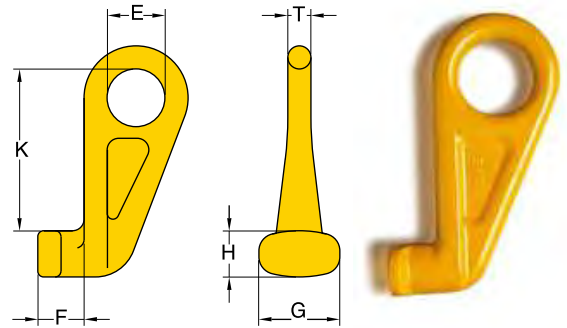

Item Code	WLL (lbs)		Desc.	Dimensions [in]						Net Weight Lbs
	4:1	5:1		E	F	G	H	K	T	
8-067-STR	27,500	22,100	Straight	2.76	1.77	2.95	1.89	7.56	0.98	8.60
8-067-45LT	27,500	22,100	Left 45°	2.76	1.77	2.95	1.89	7.56	0.98	8.60
8-067-45RH	27,500	22,100	Right 45°	2.76	1.77	2.95	1.89	7.56	0.98	8.60

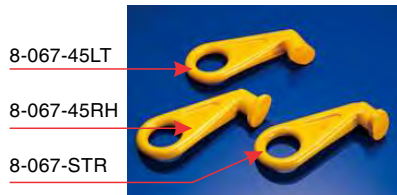

Oceanside Alloy Sorting Hook w/Handle

Sorting Hook w/ Handle

Product details

Application

- Material: Steel
- Finish: Powder Coated
- Design Factor: 4:1
- Identification: Trademark, Size/WLL, Batch Code
- Rated in Metric Ton(s)

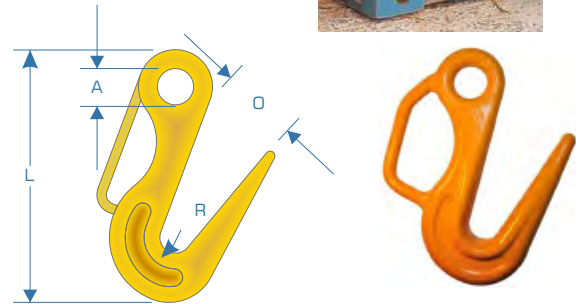

Item Code	WLL (lbs) 4:1		Dimensions [in]				Net Weight Lbs
	Bottom	Tip	A	R	L	O	
74-6-2TSH	16,500	4,400	1.38	0.63	9.69	2.81	6.25

Sling Protection
Web Slings
Round Slings
Synthetic Chain Slings
Wire Rope Slings
Chain Slings
Shackles & Turnbuckles
Hooks & Links
Lifting Points
Hoists & Blocks
Lifting Devices
Pipe & Hose Restraints
Tie Down Assemblies
Tie Down Accessories
Towing & Recovery
Rope & Cordage

VCOH Cobra - Eye Hoist Hooks

Eye Type Hoist Hook

Product details

Application

- The Cobra hook with a ring connection and of course all the advantages of a RUD - clevis hook.
- A very robust design and without a protruding tip of the hook.
- The forged safety latch engaged in the tip of the hook, and is thus protected against lateral bending.
With a triple coiled corrosion protected double leg spring.
- Thickened tip of the hook prevents improper use.
- Gauge marks for measuring the width of the hook opening .



Item Code	WLL (lbs)		Chain Size	Dimensions (in)									Net Weight
	4:1	5:1		[in]	T	A	B	C	D	E	F	G	
8502323	1,390	1,100	5/32	2.95	0.71	0.71	0.47	0.51	0.55	0.71	2.05	0.31	0.33
8502203	3,300	2,600	7/32	3.82	0.94	0.87	0.63	0.79	0.94	0.98	2.87	0.43	0.84
8502142	5,500	4,400	5/16	4.96	1.26	1.10	0.79	1.10	1.22	1.18	3.74	0.51	1.76
8502145	8,800	7,000	3/8	5.91	1.50	1.42	1.02	1.42	1.54	1.38	4.65	0.67	3.48
8502204	15,000	11,800	1/2	6.85	1.89	1.77	1.18	1.46	1.89	1.57	5.31	0.83	6.83
8502146	22,000	17,600	5/8	8.19	2.48	2.20	1.42	1.93	2.28	1.89	6.34	1.06	10.91

VCGH Cobra - Clevis Hoist Hooks

Clevis Type Hoist Hook

Product details

Application

- A robust improved version without a protruding hook tip.
- The forged safety latch engages in the tip of the hook and is thus protected against lateral bending.
- With a triple coiled corrosion protected double leg spring.
- Thickened tip of the hook to prevent misuse.
- Wear marks on both sides.
- Gauge marks for measuring the width of the hook opening
- Connecting bolt and tensioning sleeve are pre-assembled.

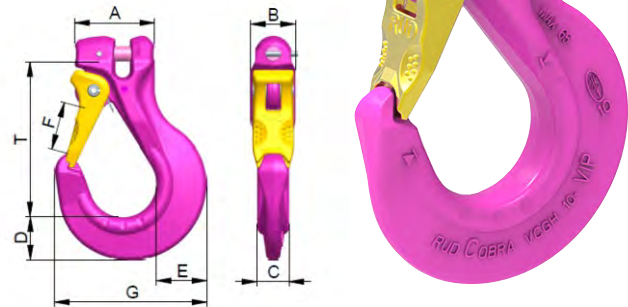

Item Code	WLL (lbs)	Chain Size	Dimensions (in)									Net Weight
			[in]	T	A	B	C	D	E	F	G	
7984439	1,390	5/32	2.20	0.79	0.55	0.49	0.51	0.55	0.71	2.05	0.26	
7100498	3,300	7/32	2.99	1.50	0.87	0.63	0.79	0.94	0.98	2.83	0.86	
7100499	5,500	5/16	3.82	1.97	1.10	0.79	1.10	1.26	1.18	3.74	1.72	
7100500	8,800	3/8	4.25	2.36	1.42	1.02	1.42	1.54	1.38	4.65	3.31	
7100501	15,000	1/2	4.96	2.99	1.81	1.18	1.46	1.89	1.57	5.31	6.26	
7100502	22,000	5/8	5.98	3.27	2.20	1.42	1.93	2.28	1.89	6.34	10.34	

WARNING: NEVER EXCEED WORKING LOAD LIMIT!

Failure to follow instructions can result in serious property damage, injury or death!

For full user manual please visit www.superslings.ca

- Sling Protection
- Web Slings
- Round Slings
- Synthetic Chain Slings
- Wire Rope Slings
- Chain Slings
- Shackles & Turnbuckles
- Hooks & Links**
- Lifting Points
- Hoists & Blocks
- Lifting Devices
- Pipe & Hose Restraints
- Tie Down Assemblies
- Tie Down Accessories
- Towing & Recovery
- Rope & Carriage

Flat Webbing Choker. Code "FM"

Web Sling Choker Hook

Product details

Application

- Material: Steel
- Finish: Powder Coated
- Design Factor: 4:1
- Identification: Trademark, Size/WLL, Batch Code
- Rated in Metric Ton(s)

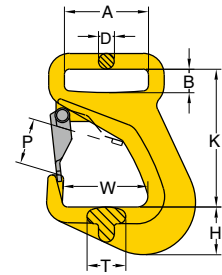
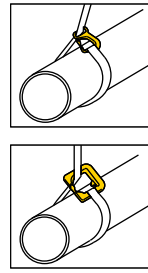

Item Code	WLL (lbs)		Dimensions (in)								Net Weight
	4:1	5:1	A	B	D	H	K	P	T	W	Lbs
8-031-02	4,400	3,500	3.19	0.94	0.55	1.73	5.51	1.73	1.57	3.15	4.85

Sliding Choker Hook

Sliding Choker Hook

Product details

Application

- Material: Steel
- Finish: Powder Coated
- Design Factor: 5:1
- Identification: Trademark, Size/WLL, Batch Code
- Rated in Metric Ton(s)

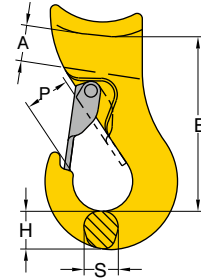

Item Code	WLL (lbs)	Wire Rope Size	Dimensions (in)					Net Weight
			A	E	H	P	S	Lbs
8-074-09/13	3,300	3/8-1/2	0.63	3.43	0.94	0.71	0.71	1.32
8-074-14/16	4,900	9/16-5/8	0.83	3.86	1.14	0.79	0.87	1.98

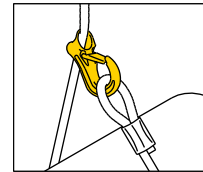

8-063 Twist Eye Choke Hook Code "KE"

Sliding Choker Hook

Product details

Application

- Material: Steel
- Finish: Powder Coated
- Design Factor: 4:1
- Identification: Trademark, Size/WLL, Batch Code
- Rated in Metric Ton(s)

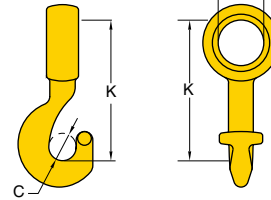

Special Order

Item Code	WLL (lbs)	Wire Rope Size	Dimensions (in)			Net Weight
			A	C	K	Lbs
8-063-07	4,400	9/32-5/16	1.26	0.75	3.74	0.88
8-063-10	6,900	3/8	1.61	0.83	4.57	1.76
8-063-13	11,700	1/2	1.97	1.06	5.91	4.41
8-063-16	17,600	5/8	2.64	1.26	7.28	6.83

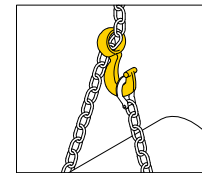

8-018 Omega Link Code "YO"

Connecting Link

Product details



Special Order

Item Code	WLL (lbs)	Chain Size	Dimensions (in)				Net Weight
			D	K	P	T	Lbs
8-018-06	2,100	7/32	0.83	1.18	0.31	0.35	0.22
8-018-07	4,500	9/32-5/16	1.06	1.42	0.35	0.43	0.44
8-018-10	7,100	3/8	1.26	1.73	0.47	0.59	0.88
8-018-13	12,000	1/2	1.65	2.17	0.63	0.67	1.76
8-018-16	18,100	5/8	1.97	2.72	0.71	0.87	3.53

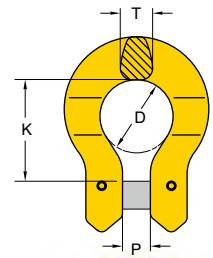
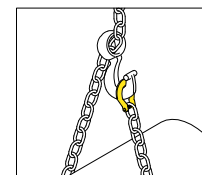

X-043 G-100 Clevis Sling Hooks

Clevis Sling Hook

Product details

Application

- Quenched and Tempered Alloy Steel.
- At least 25% greater WLL than traditional G80 products.
- Manufactured in accordance with EN 1677- 2 and ASME B30.26, ASME B30.10, PAS1061.
- Certified by DGUV GS-OA-15-05 & DGUV GS-MO-15-05
- Proof Load tested at 2.5 times the WLL with certification for each batch manufactured.
- Design Factor 4:1.
- Fatigue rated to 20,000 cycles at 1.5 times the WLL.
- Tempering temperature minimum 400°C
- Magnaflux crack detection is performed 100% on each batch.



Safety is our first priority™



X-P026

For load pin replacement



8-P044

For latch replacement

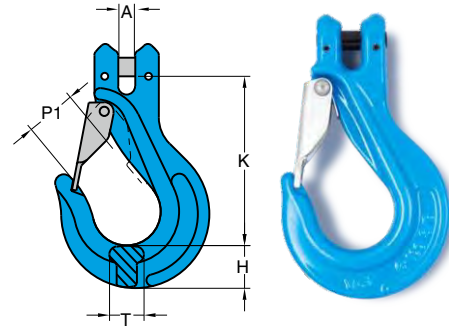

Item Code	WLL	Chain Size	Dimensions (in)					Net Weight
			A	H	K	P1	T	
	4:1 lbs	[in]	A	H	K	P1	T	lbs
X-043/S-06	3,200	7/32	0.24	0.91	3.82	0.91	0.59	0.66
X-043/S-07	5,700	9/32-5/16	0.35	0.87	3.86	1.06	0.71	1.32
X-043/S-10	8,800	3/8	0.43	1.18	4.80	1.34	0.94	2.43
X-043/S-13	15,000	1/2	0.55	1.46	5.79	1.73	1.18	5.07
X-043/S-16	22,600	5/8	0.67	1.65	6.54	1.89	1.54	8.38
X-043/S-20	35,300	3/4	0.94	2.52	8.15	2.24	1.89	19.18
X-043/S-22	42,700	7/8	0.98	2.40	8.54	2.87	2.05	20.94

X-026 G-100 Self-Locking Clevis Hook

Clevis Self-Locking Hook

Product details

Application

- Quenched and Tempered Alloy Steel.
- At least 25% greater WLL than traditional G80 products.
- Manufactured in accordance with EN 1677- 3 and ASME B30.26, ASME B30.10, PAS1061.
- Certified by DGUV GS-MO-15-05
- Proof Load tested at 2.5 times the WLL with certification for each batch manufactured.
- Design Factor 4:1.
- Fatigue rated to 20,000 cycles at 1.5 times the WLL.
- Tempering temperature min 400°C
- Magnaflux crack detection is performed 100% on each batch.



Safety is our first priority™



X-P026

For load pin replacement



8-P025T

For trigger replacement

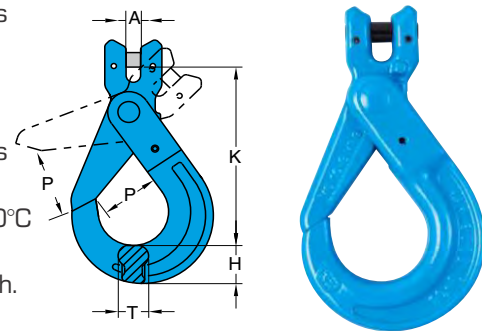

Item Code	WLL	Chain Size	Dimensions (in)					Net Weight
			A	H	K	P	T	
	4:1 lbs	[in]	A	H	K	P	T	lbs
X-026-06	3,200	7/32	0.24	0.75	3.66	1.10	0.59	0.88
X-026-07	5,700	9/32-5/16	0.35	0.94	4.69	1.34	0.79	1.98
X-026-10	8,800	3/8	0.43	1.18	5.59	1.73	1.02	3.09
X-026-13	15,000	1/2	0.55	1.54	7.01	2.01	1.18	6.61
X-026-16	22,600	5/8	0.71	1.93	8.39	2.36	1.42	11.02
X-026-20	35,300	3/4	0.83	2.56	9.61	2.76	2.09	24.25
X-026-22	42,700	7/8	0.94	2.48	10.75	3.15	1.93	29.76

X-042N G-100 Clevis Grab Hook

Clevis Sling Hook

Product details

Application

- Quenched and Tempered Alloy Steel.
- At least 25% greater WLL than traditional G80 products.
- Manufactured in accordance with DIN PAS 1061, EN 1677-1 and ASTM A952/A 952M.
- Proof Load tested at 2.5 times the WLL with certification for each batch manufactured.
- Design Factor 4:1, Fatigue rated to 20,000 cycles at 1.5 times the WLL.
- Tempering temperature min 400°C
- Not for use with Omega Link
- Enables full WLL while in use, thanks to supporting wings which prevent chain link deformation.
- Certified by DGUV GS-MO-15-05



Safety is our first priority™



X-P026
For load pin replacement

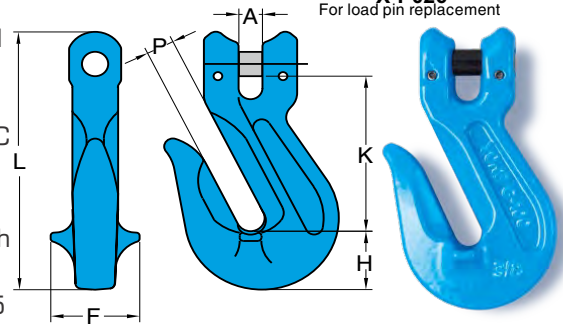

Item Code	WLL	Chain Size	Dimensions (in)						Net Weight
			A	F	H	K	L	P	
	4:1 lbs	[in]							lbs
X-042-06	3,200	7/32	0.28	0.98	0.71	1.85	3.11	0.31	0.44
X-042-07	5,700	9/32-5/16	0.39	1.18	0.87	2.13	3.66	0.39	0.88
X-042-10	8,800	3/8	0.43	1.61	1.14	3.03	5.04	0.51	1.76
X-042-13	15,000	1/2	0.59	2.05	1.50	3.90	6.50	0.67	3.53
X-042-16	22,600	5/8	0.71	2.24	1.77	4.49	7.68	0.83	5.95
X-042-20	35,300	3/4	0.87	2.87	2.05	5.12	8.74	0.91	10.58
X-042-22	42,700	7/8	0.94	2.76	2.20	5.47	9.72	1.02	14.11

X-046 G-100 Clevis Foundry Hook

Clevis Foundry Hook

Product details

Application

- Quenched and Tempered Alloy Steel.
- At least 25% greater WLL than traditional G80 products.
- Manufactured in accordance with DIN PAS 1061 and ASTM A952/A 952M, EN 1677-1,
- Proof Load tested at 2.5 times the WLL with certification for each batch manufactured.
- Design Factor 4:1.
- Fatigue rated to 20,000 cycles at 1.5 times the WLL.
- Tempering temperature minimum 400°C
- Not used for general chain sling applications, rather for use where a large throat opening is necessary.
- Before using the hook, check whether hooks without safety latches are allowed to be used for the particular application.



Safety is our first priority™



X-P026
For load pin replacement

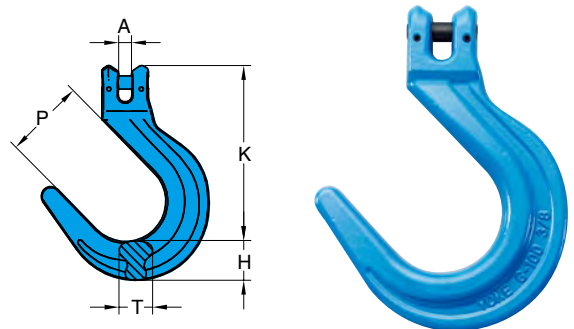

Item Code	WLL	Chain Size	Dimensions (in)					Net Weight
			A	H	K	P	T	
	4:1 lbs	[in]						lbs
X-046-07	5,700	9/32-5/16	0.35	1.06	5.24	2.44	0.75	2.09
X-046-10	8,800	3/8	0.43	1.26	6.42	2.91	0.91	3.97
X-046-13	15,000	1/2	0.55	1.54	7.87	3.46	1.26	7.94
X-046-16	22,600	5/8	0.71	1.85	9.41	3.86	1.61	14.11
X-046-20	35,300	3/4	0.83	2.44	12.01	4.45	1.81	24.69

X-015 G-100 Connecting Link



Connecting Link
Product details

Item Code	WLL	Chain Size	Dimensions [in]				Net Weight
	4:1 lbs	[in]	A	B	D	K	lbs
X-015-06	3,200	7/32	0.59	0.71	0.28	1.77	0.18
X-015-07	5,700	9/32-5/16	0.71	0.98	0.35	2.32	0.44
X-015-10	8,800	3/8	0.98	1.10	0.43	2.72	0.66
X-015-13	15,000	1/2	1.18	1.50	0.63	3.62	1.54
X-015-16	22,600	5/8	1.42	1.61	0.75	3.98	2.65
X-015-20	35,300	3/4	1.65	1.97	0.91	4.80	4.63
X-015-22	42,700	7/8	1.93	2.48	0.94	5.98	7.72
X-015-26	59,700	1	2.17	2.60	1.18	6.38	10.58

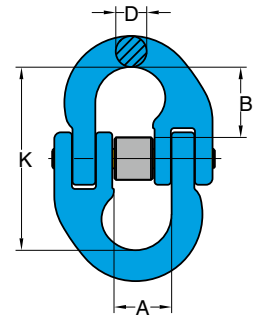

X-016 G-100 Web Sling Connector



Connecting Link
Product details

Item Code	WLL	Chain Size	Dimensions [in]					Net Weight
	4:1 lbs	[in]	A	B	D	K	W	lbs
X-016-06	3,200	7/32	0.59	0.67	0.28	2.17	1.50	0.44
X-016-07	5,700	9/32-5/16	0.71	0.87	0.35	2.44	1.57	0.66
X-016-10	8,800	3/8	0.98	1.02	0.43	3.07	1.85	1.32
X-016-13	15,000	1/2	1.18	1.38	0.63	3.74	2.09	2.43
X-016-16	22,600	5/8	1.42	1.50	0.75	4.53	2.64	4.41
X-016-20	35,300	3/4	1.65	1.81	0.87	5.20	3.15	7.05
X-016-22	42,700	7/8	1.93	2.32	0.94	7.36	4.92	16.98

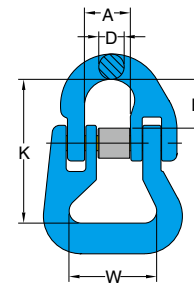

X-032 G-100 100 Web Sling Hook



Coupling Self-Locking Hook
Product details

Item No.	Working Load Limit (lbs)		Dimensions (mm)					Net Weight
	4:1	5:1	H	K	P	T	W	lbs
74-X-032-01	2,200	1,700	0.79	3.50	0.98	0.59	1.69	1.54
74-X-032-02	4,400	3,500	1.06	4.57	1.18	0.79	2.09	3.31
74-X-032-03	6,600	5,200	1.26	4.69	1.26	1.02	2.52	5.29
74-X-032-05	11,000	8,800	1.73	5.71	1.77	1.50	2.40	7.72

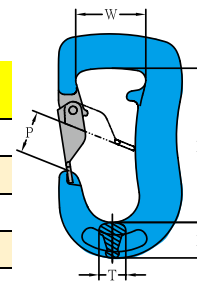

8-066 G-80 "YR" Clevis Shackle



Connecting Link
Product details

Special Order

Item Code	WLL (lbs)	Chain Size	Dimensions [in]							Net Weight
	4:1	[in]	A	C	G	K	L	M	W	lbs
8-066-07	4,500	9/32-5/16	0.35	3.11	1.34	2.32	1.38	0.63	1.30	0.88
8-066-10	7,100	3/8	0.43	3.66	1.57	3.07	1.89	0.79	1.34	1.76
8-066-13	12,000	1/2	0.55	4.65	1.73	3.86	2.52	0.87	1.93	3.09
8-066-16	18,100	5/8	0.71	5.55	2.13	4.41	2.72	1.10	2.36	5.29

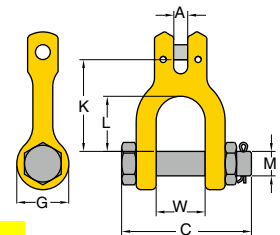

- Sling Protection
- Web Slings
- Round Slings
- Synthetic Chain Slings
- Wire Rope Slings
- Chain Slings
- Shackles & Turnbuckles
- Hooks & Links**
- Lifting Points
- Hoists & Blocks
- Lifting Devices
- Pipe & Hose Restraints
- Tie Down Assemblies
- Tie Down Accessories
- Towing & Recovery
- Rope & Cordage

8-078 Grade 80 Shortening Clutch w/ Half-Link

Chain Shortener

Product details

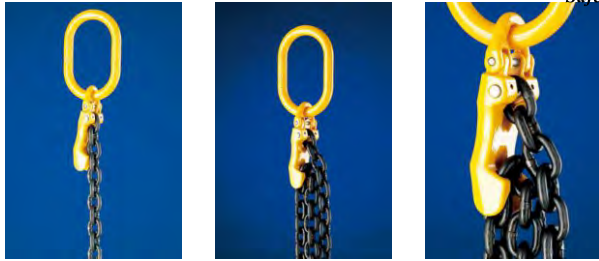
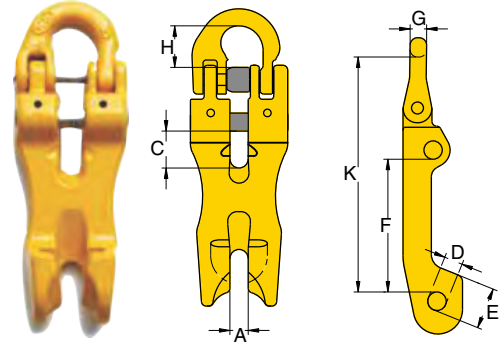

Item Code	WLL (lbs)	Chain Size	Dimensions (in)								Net Weight
			A	C	D	E	F	H	G	K	
	4:1	[in]									lbs
8-078-07	4,500	9/32-5/16	0.47	0.79	0.39	0.91	2.76	0.87	0.35	5.04	1.54
8-078-10	7,100	3/8	0.51	1.02	0.47	1.14	3.43	1.02	0.43	6.06	2.87
8-078-13	12,000	1/2	0.59	1.30	0.63	1.46	4.53	1.42	0.59	7.99	6.17
8-078-16	18,100	5/8	0.83	1.54	0.75	1.81	5.63	1.54	0.75	9.76	11.68

055 Grade 80 Coupling Sling Hook. Code "EB"

Chain Shortener

Product details

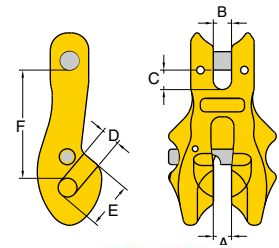
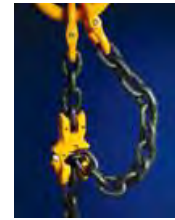

Special Order

Item Code	WLL (lbs)	Chain Size	Dimensions (in)						Net Weight
			A	B	C	D	E	F	
	4:1	[in]							lbs
8-061-06	2,100	7/32	0.28	0.28	0.39	0.28	0.71	1.97	0.66
8-061-07	4,500	9/32-5/16	0.39	0.39	0.39	0.39	0.94	2.20	1.10
8-061-10	7,100	3/8	0.47	0.47	0.47	0.47	1.10	2.60	1.98
8-061-13	12,000	1/2	0.59	0.59	0.63	0.63	1.54	3.46	4.85
8-061-16	18,100	5/8	0.71	0.83	0.75	0.75	1.89	4.06	8.16
8-061-20	28,300	3/4	0.87	0.91	0.91	0.83	2.17	5.20	12.79

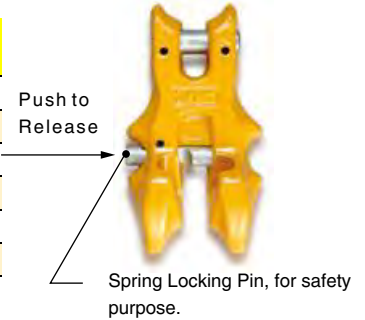

Grade 100 Grab Hook Shortening Leg

Chain Shortener

Product details

Item Code	WLL (lbs)	Chain Size	Dimensions (in)				Net Weight
			A	B	C	D	
	4:1	[in]					lbs
53-ADJ932	5,700	9/32-5/16	0.29	4.91	2.55	6.05	1.76
53-ADJ38	8,800	3/8	0.40	5.49	3.59	7.95	3.53
53-ADJ12	15,000	1/2	0.52	8.82	4.71	10.88	7.06
53-ADJ58	22,600	5/8	0.64	10.95	5.79	13.55	11.9

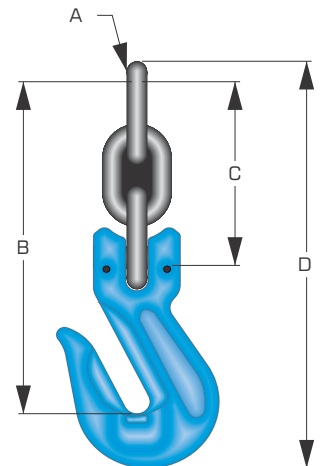

Midgrab Chain Shortener

Chain Shortener

Product details

Application

- Instant mounting and positioning on any part of the chain.
- Designed to prevent inadvertent chain disengagement.
- Can be set idle on the chain leg when shortening is not required
- For high visibility in the field.
- Fatigue tested
- Forged alloy steel
- Quenched and tempered
- 100% proof load of each MIG
- Secure mounting with locking set on any desired part of the chain with one chain direction open for shortening
- Close-open function in both chain directions for safe retention of the chain
- Spring and trigger in stainless steel
- Easy-to-use shortening in either chain direction up-down
- The design makes it easy to place the MIG on the chain correctly.

Locking options



MIG C



MIG CC



MIG L



MIG LC



f-locking devices for MIG

Note! The MIG should be used with at least one locking devices.

L - fixed locking set
for fixed mounting



Code:

- L-8: B14905
- L-10: B14915
- L-13: B14917

C - close/open locking set

Spring operated locking device. Can be placed either in open or closed position.





Code:

- C-8: B14904
- C-10: B14914
- C-13: B14916

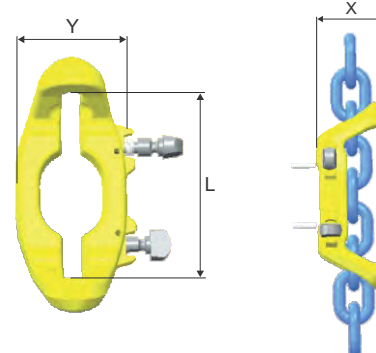
Item Code	WLL (lbs) 4:1	Dimensions (in)			Net Weight lbs
		L	X	Y	
	EN 1677-4				
MIG- 8-10	5,700.00	3.74	1.97	2.36	1.38
MIG-10-10	8,800.00	4.92	2.76	3.03	2.34
MIG-13-10	15,000.00	5.91	3.54	3.15	5.38
MIG CC-8-10	5,700.00	3.74	1.97	2.36	2.18
MIG CC-10-10	8,800.00	4.92	2.76	3.03	2.18
MIG CC-13-10	15,000.00	5.91	3.54	3.15	5.73



YOKE Insulation Solution

- YOKE Insulated Swivel is designed for winch protection in overhead crane during welding operations.
- Heavy hoisting with a strong but lightweight system.
- Individual swivels & components are 100% proof load tested to a minimum of 2.5 times the working load limit.
- All Swivels are individually tested during manufacturing to assure 1000 Volts insulating property. Test certificate is packaged with each unit shipped.
- YOKE Insulated Swivels are designed with ball bearing which performs to fully swivel under Load.
- Acquired  certificate approved by Deutsche Gesetzliche Unfallversicherung (DGUV) . 

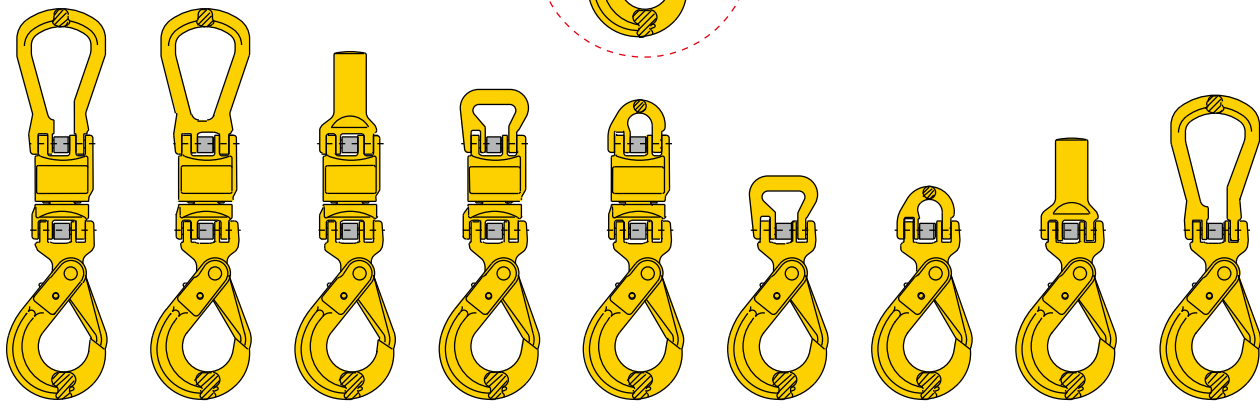
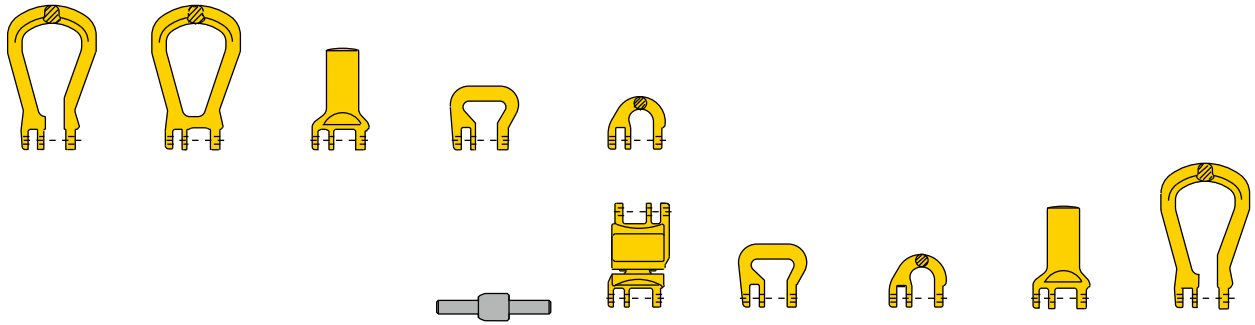

1000 Volts Resistance

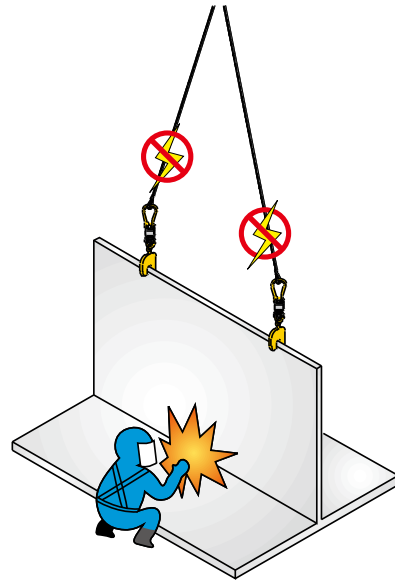

- Sling Protection
- Web Slings
- Round Slings
- Synthetic Chain Slings
- Wire Rope Slings
- Chain Slings
- Shackles & Turnbuckles
- Hooks & Links**
- Lifting Points
- Hoists & Blocks
- Lifting Devices
- Pipe & Hose Restraints
- Tie Down Assemblies
- Tie Down Accessories
- Towing & Recovery
- Rope & Cordage

Yoke Coupling System

YOKE's innovative, fine design with " Coupling Pin " system hook is able to solve any of your problems in Chain, Wire Rope and Synthetic Slings. The hook :

- 1. Create safer lifting with the use of " Self Locking " system.
- 2. Assembly is fast and easy with only a hammer required.
- 3. Acquired certificate approved by BG German company.
- 4. Patent :Taiwan, China, France, Germany, Italy, Japan,USA, Switzerland.

088N Grade 80 Insulated Blank Swivel

"BSI" Insulated Blank Swivel

Product details



Item Code	WLL (lbs)	Chain Size	Dimensions (in)		Net Weight
			D	L	
	4:1	[in]	D	L	lbs
8-088N-07	4,500	9/32-5/16	1.97	2.95	1.32
8-088N-10	7,100	3/8	2.44	3.70	0.05
8-088N-13	12,000	1/2	3.03	4.84	0.09
8-088N-16	18,100	5/8	3.70	5.63	0.17
8-088N-20	28,300	3/4	4.29	6.46	0.26

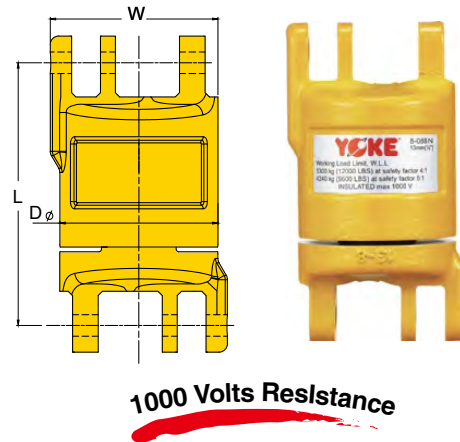

1000 Volts Resistance

051 Grade 80 Coupling Master Link. Code "EC"

Coupling Masterlink

Product details



Item Code	WLL (lbs)	Chain Size	Dimensions (in)					Net Weight
			A	H	K	T	W	
	4:1	[in]	A	H	K	T	W	lbs
8-051-07	4,500	9/32-5/16	0.59	0.59	3.94	0.59	1.97	0.66
8-051-10	7,100	3/8	0.75	0.75	5.00	0.75	2.60	1.32
8-051-13	12,000	1/2	0.98	0.87	5.71	0.91	2.83	2.20
8-051-16	18,100	5/8	1.18	1.02	6.85	0.98	3.15	3.53
8-051-20	28,300	3/4	1.42	1.42	7.95	1.22	4.09	6.17

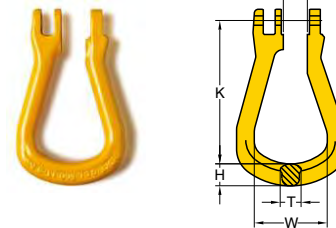

054 Grade 80 Half Coupling Link. Code "BST"

Half-Coupling Link

Product details



Item Code	WLL (lbs)	Chain Size	Dimensions (in)				Net Weight
			A	D	K	L	
	4:1	[in]	A	D	K	L	lbs
8-054-06	2,100	7/32	0.59	0.28	0.67	0.87	0.22
8-054-07	4,500	9/32-5/16	0.71	0.35	0.87	1.10	0.22
8-054-10	7,100	3/8	0.98	0.43	1.02	1.34	0.44
8-054-13	12,000	1/2	1.18	0.63	1.38	1.77	0.88
8-054-16	18,100	5/8	1.42	0.75	1.50	1.97	1.32
8-054-20	28,300	3/4	1.65	0.87	1.81	2.36	2.43
8-054-22	34,200	7/8	1.93	0.94	2.32	2.99	3.75
8-054-26	47,700	1	2.17	1.18	2.44	3.15	5.95
8-054-32	72,300	1-1/4	2.72	1.42	3.11	3.94	11.02

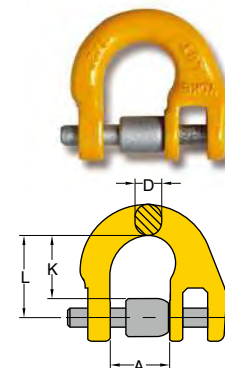



053 Grade 80 Round Sling Coupling. Code "YW"

Round Sling Coupling

Product details



Safety is our first priority™

Item Code	WLL (lbs)	Chain Size	Dimensions (in)				Net Weight
			A	B	K	W	
	4:1	[in]	A	B	K	W	lbs
8-053-06	2,500	7/32	0.59	0.87	1.30	1.50	0.44
8-053-07	4,500	9/32-5/16	0.71	0.94	1.30	1.57	0.44
8-053-10	7,100	3/8	0.98	1.14	1.65	1.85	0.88
8-053-13	12,000	1/2	1.18	1.38	2.01	2.09	1.54
8-053-16	18,100	5/8	1.42	1.73	2.48	2.64	2.87
8-053-20	28,300	3/4	1.65	2.05	2.80	3.15	4.63
8-053-22	34,200	7/8	1.93	2.83	4.41	4.92	12.57
8-053-26	47,700	1	2.17	3.31	5.12	5.91	19.84
8-053-32	72,300	1-1/4	2.72	3.35	6.50	7.48	30.86

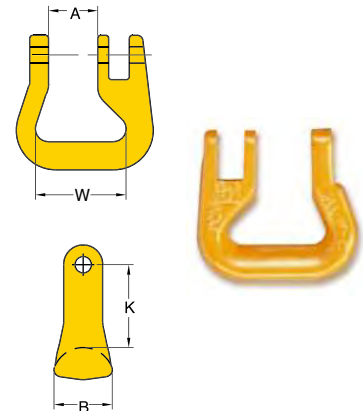

055 Grade 80 Coupling Sling Hook. Code "EB"

Coupling Sling Hook

Product details



Safety is our first priority™

Item Code	WLL (lbs)	Chain Size	Dimensions (in)				Net Weight
			H	K	P	T	
	4:1	[in]	H	K	P	T	lbs
8-055-07	4,500	9/32-5/16	0.91	3.66	1.18	0.75	0.88
8-055-10	7,100	3/8	1.22	4.53	1.42	0.91	1.98
8-055-13	12,000	1/2	1.42	5.55	1.65	1.10	3.97
8-055-16	18,100	5/8	1.77	6.54	1.85	1.26	6.61
8-055-20	28,300	3/4	1.89	7.52	2.05	1.69	10.36

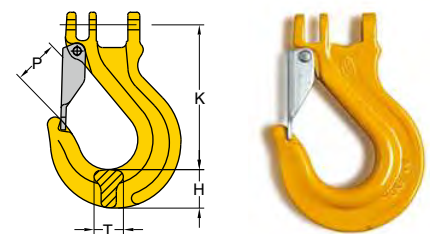

023 Grade 80 Coupling Self Locking Hook. Code "YL"

Coupling Self-Locking Hook

Product details



Safety is our first priority™

Item Code	WLL (lbs)	Chain Size	Dimensions (in)				Net Weight
			H	K	P	T	
	4:1	[in]	H	K	P	T	lbs
8-023-06	2,500	7/32	0.75	4.13	1.14	0.59	1.10
8-023-07	4,500	9/32-5/16	0.94	5.35	1.34	0.79	1.76
8-023-10	7,100	3/8	1.18	6.06	1.73	1.02	2.87
8-023-13	12,000	1/2	1.54	7.95	2.17	1.18	6.17
8-023-16	18,100	5/8	1.93	9.53	2.36	1.42	12.57
8-023-20	28,300	3/4	2.44	10.12	3.54	1.89	18.74
8-023-22	34,200	7/8	2.48	11.97	3.15	1.93	24.25
8-023-26	47,700	1	2.72	12.95	3.90	2.20	33.07

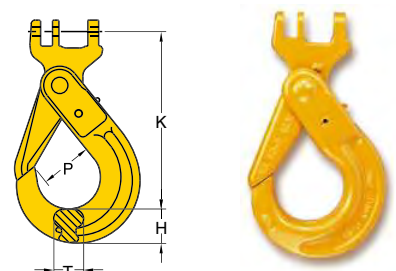

Sling Protection
Web Slings
Round Slings
Synthetic Chain Slings
Wire Rope Slings
Chain Slings
Shackles & Turnbuckles
Hooks & Links
Lifting Points
Hoists & Blocks
Lifting Devices
Pipe & Hose Restraints
Tie Down Assemblies
Tie Down Accessories
Towing & Recovery
Rope & Cordage

X-003 G-100 Masterlink



Masterlink

Product details

Application

- Quenched and Tempered Alloy Steel.
- At least 25% greater WLL than traditional G80 products.
- Manufactured in accordance with ASTM A906/A906M, ASTMA952/A952M, ASME B30.9, ASME B30.10, ASME B30.26 and OSHA 1910.184, EN-1677-4
- Proof Load tested at 2.5 times the WLL with certification for each batch manufactured.
- Design Factor 4:1.
- Fatigue rated to 20,000 cycles at 1.5 times the WLL.
- Tempering temperature at a minimum of 400°C.
- Designed for Wire Rope and Chain.
- Each link is marked with batch number that links to the test certificate with traceability to raw materials.

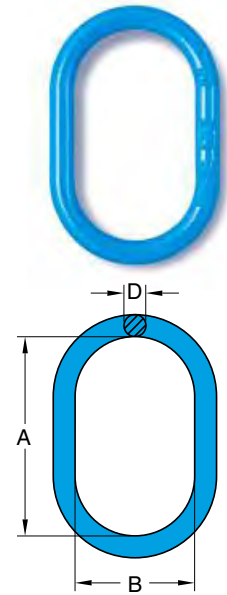

Item No.	WLL 0-45°		Chain Size Grade 100 (in)		Trade Size (in)	Dimensions (in)			Net Weight lbs
	4:1 lbs	5:1 lbs	1 Leg	2 Leg		D	IL	IW	
X-003-06	3,100	2,500	7/32		3/8	0.43	3.94	2.36	0.44
X-003-0806	6,400	5,100	9/32-5/16	7/32	1/2	0.55	4.72	2.76	1.10
X-003-1008	12,000	9,000	3/8	9/32-5/16	5/8	0.67	5.51	3.15	1.54
X-003-13	15,000	12,300	1/2		3/4	0.75	5.91	3.54	2.43
X-003-1310	19,000	15,000	1/2	3/8	7/8	0.87	6.30	3.74	3.31
X-003-16	22,000	17,600	5/8		1	0.98	7.48	4.33	5.07
X-003-1613	31,100	24,900	5/8	1/2	1 1/8	1.10	7.09	4.13	5.95
X-003-19	35,300	28,200	3/4		1 1/4	1.18	7.87	4.72	7.72
X-003-2216	46,300	37,000	7/8	5/8	1 3/8	1.34	9.45	5.51	11.68
X-003-26	58,400	46,700	1		1 1/2	1.50	9.84	5.91	16.31

DNV 2.7-1 Master Link Assembly

Clevis Shackle

Product details

Application

- Material: Alloy Steel
- Standard: EN 1677-4, ASME B30.26, DNV 2.7-1
- Finish: Painted Orange
- Design Factor: 5:1 (Wire Sling)
- Identification: Trademark, Size/WLL, Batch Code
- Rated in Metric Ton(s)



Item Code	WLL		Dimensions (in)						Weight lbs
	lbs (4:1)	lbs (5:1)	D	IL	IW	d	il	lw	
2-MA16QA	11,200	9,000	0.63	5.91	2.95	0.51	4.92	2.36	2.90
2-MA23QA	15,900	12,800	0.87	10.63	5.51	0.63	5.91	2.95	8.40
2-MA22QAS	24,200	19,500	0.87	6.38	3.54	0.79	5.51	2.76	7.90
2-MA25QA	24,200	19,500	0.98	10.63	5.51	0.79	5.51	2.76	11.70
2-MA26QA	32,400	26,000	1.10	10.63	5.51	0.79	5.51	2.76	13.00
2-MA28QAS	39,900	32,000	1.10	7.87	4.33	0.87	5.51	2.76	12.10
2-MA32QA	46,900	37,700	1.26	10.63	5.51	1.02	7.48	4.02	21.40
2-MA36QA	63,300	50,700	1.42	10.63	5.51	1.10	7.48	3.94	26.20
2-MA40QA	77,400	61,900	1.57	11.02	6.10	1.26	7.87	4.33	36.10
2-MA45QA	105,400	84,400	1.77	12.60	6.89	1.42	8.86	4.92	51.80
2-MA50QA	123,900	99,200	1.97	13.78	7.68	1.57	10.24	5.12	71.20

Sling Protection
Web Slings
Round Slings
Synthetic Chain Slings
Wire Rope Slings
Chain Slings
Shackles & Turnbuckles
Hooks & Links
Lifting Points
Hoists & Blocks
Lifting Devices
Pipe & Hose Restraints
Tie Down Assemblies
Tie Down Accessories
Towing & Recovery
Rope & Carriage

V-line Grade 80 Alloy Master Links

Masterlink

Product details

Application

- Alloy Steel – Quenched and Tempered
- Individually proof tested per ASTM 906/952 prescribed loads
- Meet EN1677 standard (20,000 cycle fatigue test)
- Permanently embossed with VGD, size, model number and trace code
- Approved for overhead lifting when all components are grade 80
- Proof tested to 2 times the Working Load Limit (WLL)
- Design factor 4:1

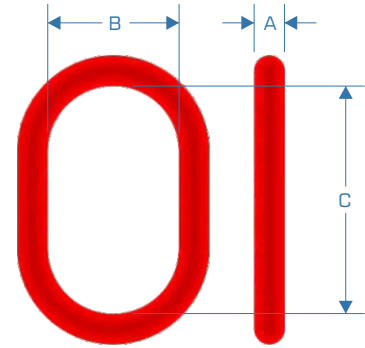

Item Code	Dimensions			WLL (lbs)		Weight (lbs)	Chain Size Gr. 80	
	A	B	C	(4:1)	(5:1)		Single	Double
5983-00046	(1/2") 0.50	2.75	4.72	6,100	4,900	0.83	9/32-5/16	9/32
5983-10001	(5/8") 0.63	3.15	5.50	7,750	6,200	1.50	3/8	5/16
5983-10002	(3/4") 0.75	3.75	6.30	12,300	9,800	2.60	1/2	3/8
5983-10003	(1") 1.00	4.33	7.50	20,800	16,600	5.40	5/8	1/2
5983-10004	(1-1/4") 1.25	5.10	9.00	31,300	25,000	10.30	3/4	5/8
5983-10005	(1-1/2") 1.50	5.90	10.80	49,000	39,200	16.50	7/8	3/4
5983-10006	(1-3/4") 1.75	7.10	13.40	73,500	58,800	28.20	1	7/8

V-line Grade 80 Alloy Sub-assembly

Masterlink Assembly

Product details

Application

- Alloy Steel – Quenched and Tempered
- Individually proof tested per ASTM 906/952 prescribed loads
- Meet EN1677 standard (20,000 cycle fatigue test)
- Permanently embossed with VGD, size, model number and trace code
- Approved for overhead lifting when all components are grade 80
- Proof tested to 2 times the Working Load Limit (WLL)
- Design factor 4:1

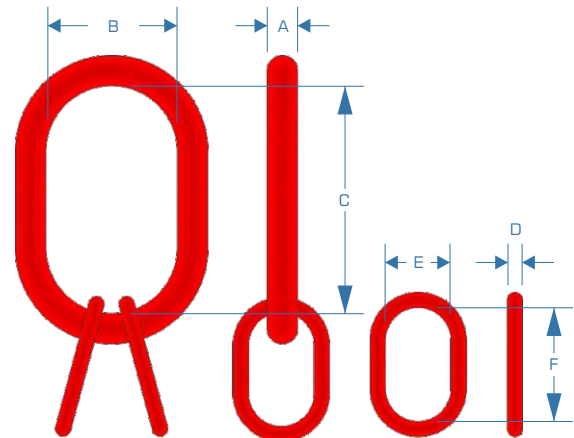

Item Code	Chain Size	Dimensions (in)						WLL @ 60° (lbs)	Weight (lbs)
		A	B	C	D	E	F		
5994-00401	9/32	(3/4") 0.75	3.75	6.30	0.50	2.36	4.33	12,300	4.20
5994-00601	3/8	(1") 1.00	4.33	7.50	0.75	3.75	6.30	20,800	10.70
5994-00801	1/2	(1-1/4") 1.25	5.10	9.00	1.00	4.33	7.50	31,300	22.30
5994-01001	5/8	(1-1/2") 1.50	5.90	10.80	1.13	5.10	9.05	49,000	32.40
5994-01201	3/4	(1-3/4") 1.75	7.10	13.40	1.25	5.10	9.05	73,500	58.60

VGD WELDLESS PEAR SHAPED LINKS

Pear Ring

Product details

Application

- Drop Forged - Alloy Steel – Quenched and Tempered
- Hot dipped galvanized finish
- Permanently embossed with Vanguard, size, Working Load Limit (WLL) and trace code
- Proof Load 2 times WLL
- Design factor 5 times WLL

NOTE!: Working Load Limit (WLL) is based upon single leg (in-line load), or resultant load on multiple legs with an included angle less than or equal to 120°

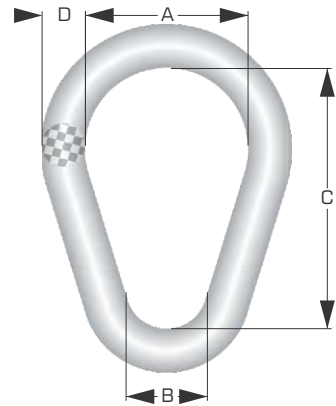

Item Code	Dimension (in)				WLL lbs	Net Weight lbs
	D	A	B	C		
75-1013897	3/8	1.50	0.75	2.25	1,800	0.23
75-1013913	1/2	2.00	1.00	3.00	7,000	0.55
75-1013931	5/8	2.50	1.25	3.75	9,000	1.10
75-1013959	3/4	2.75	1.38	4.50	12,300	1.95
75-1013977	7/8	3.50	1.75	5.25	15,000	2.78
75-1013995	1	3.75	1.88	6.00	24,360	4.30
75-1014011	1-1/4	5	2.50	7.75	16,750	7.60
75-1014039	1-3/8	5.50	2.75	8.25	20,500	11.30

OCE WELDLESS ROUND RINGS

Pear Ring

Product details

Application

- Standard: RR-C-271F
- Finish: Painted Yellow
- Design Factor: 6:1
- Identification: Trademark, Size/WLL, Batch Code

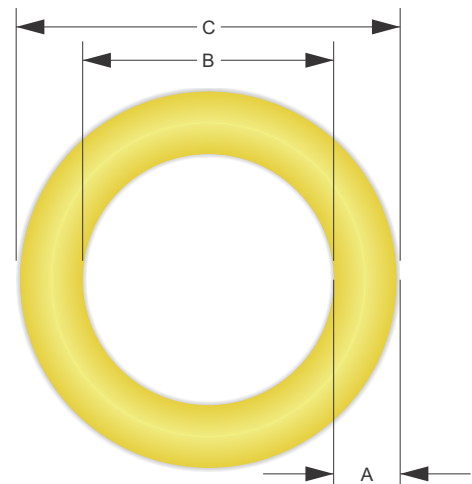

Item Code	Size	Dimension (in)			WLL lbs	Net Weight lbs
		A	B	C		
75-1013780	7/8 x 4	7/8	4.00	5.75	7200	2.72
75-1013806	7/8 x 5-1/2	7/8	5.50	7.25	5600	3.47
75-1013824	1 x 4	1	4.00	6.00	10,800	3.69
75-1013482	1-1/8 x 6	1-1/8	6.00	8.25	10,400	6.60
75-1013860	1-1/4 x 5	1-1/4	5.00	7.50	17,000	8.36
75-1013888	1-1/4 x 10	1-1/4	10.00	12.50	17,000	12.65

- Sling Protection
- Web Slings
- Round Slings
- Synthetic Chain Slings
- Wire Rope Slings
- Chain Slings
- Shackles & Turnbuckles
- Hooks & Links
- Lifting Points
- Hoists & Blocks
- Lifting Devices
- Pipe & Hose Restraints
- Tie Down Assemblies
- Tie Down Accessories
- Towing & Recovery
- Rope & Cordage



MG - Master Grab

Masterlink

Product details



All-in-one compact top link.
Safety factor 4:1

Item Code	WLL [lbs]	Chain Size	Dimensions [in]				Net Weight
			L	A	E	D	
	4:1	[in]					lbs
MG-6-10	3,300	7/32	5.71	3.46	2.36	0.59	1.11
MG-8-10	5,700	9/32-5/16	6.73	3.62	2.36	0.71	2.12
MG-10-10	8,800	3/8	8.31	4.45	2.95	0.87	4.09
MG-13-10	15,000	1/2	10.28	5.43	3.54	1.02	7.88
MG-16-10	22,600	5/8	12.24	6.18	4.13	1.22	13.30

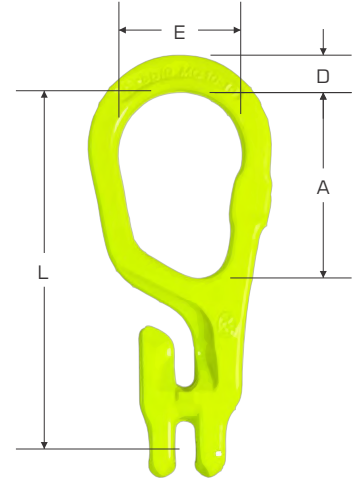

CG - C-Grab

Masterlink

Product details



For use with master link, eye hooks and choke. All GrabiQ C-connectors can be equipped with Quick Pin.

Item Code	WLL [lbs]	Chain Size	Dimensions [in]				Net Weight
			L	B	E	D	
	4:1	[in]	L	B	E	D	lbs
CG-6-10	3,300	7/32	3.15	0.43	0.94	0.75	0.79
CG-8-10	5,700	9/32-5/16	4.21	0.47	1.26	0.94	1.74
CG-10-10	8,800	3/8	5.28	0.59	1.57	1.14	3.48
CG-13-10	15,000	1/2	6.77	0.71	2.05	1.50	7.28
CG-16-10	22,600	5/8	8.46	0.87	2.52	1.85	13.40

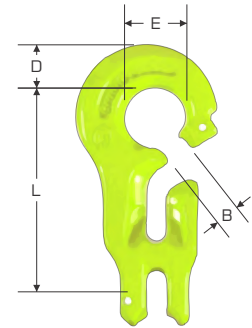

CL - C-Lok

Masterlink

Product details



For use with master links, eye hooks and choke. All GrabiQ C-connectors can be equipped with Quick Pin.

Item Code	WLL [lbs]	Chain Size	Dimensions [in]				Net Weight
			L	B	E	D	
	4:1	[in]	L <td>B <td>E <td>D <td>lbs</td> </td></td></td>	B <td>E <td>D <td>lbs</td> </td></td>	E <td>D <td>lbs</td> </td>	D <td>lbs</td>	lbs
CL-6-10	3,300	7/32	1.69	0.43	0.94	0.71	0.49
CL-8-10	5,700	9/32-5/16	2.28	0.47	1.26	0.94	1.12
CL-10-10	8,800	3/8	2.91	0.59	1.57	1.14	2.10
CL-13-10	15,000	1/2	3.70	0.71	2.05	1.50	4.69
CL-16-10	22,700	5/8	4.69	0.87	2.52	1.89	8.20

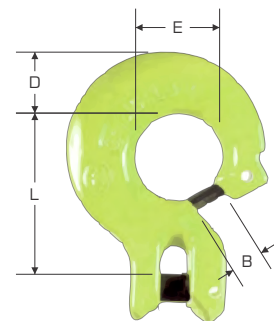

Sling Protection
Web Slings
Round Slings
Synthetic Chain Slings
Wire Rope Slings
Chain Slings
Shackles & Turnbuckles
Hooks & Links
Lifting Points
Hoists & Blocks
Lifting Devices
Pipe & Hose Restraints
Tie Down Assemblies
Tie Down Accessories
Towing & Recovery
Rope & Cordage



MGD - Master Grab Duo

Masterlink

Product details



All-in-one compact top link for 2-leg slings.
Safety factor 4:1

Item Code	WLL [lbs]	Chain Size	Dimensions [in]				Net Weight
			L	A	E	D	
	4:1	[in]					lbs
MGD-6-10	4,600	7/32	5.67	3.54	2.36	0.67	1.46
MGD-8-10	7,700	9/32-5/16	6.73	3.94	2.95	0.83	2.97
MGD-10-10	12,300	3/8	8.31	4.88	3.54	0.94	5.32
MGD-13-10	20,900	1/2	10.31	5.87	4.13	1.22	10.46
MGD-16-10	30,900	5/8	12.20	6.89	4.72	1.38	17.98

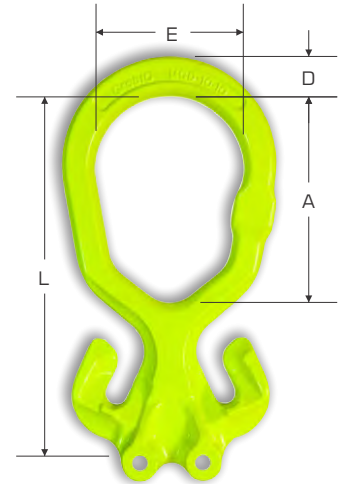

CGD - C-Grab Duo

Masterlink

Product details



For use with master links. All GabiQ C-connectors can be equipped with Quick Pin.

Item Code	WLL [lbs]	Chain Size	Dimensions [in]				Net Weight
			L	B	E	D	
	4:1	[in]					lbs
CGD-6-10	4,600	7/32	3.11	0.43	0.94	0.87	1.12
CGD-8-10	7,700	9/32-5/16	4.21	0.47	1.26	1.14	2.61
CGD-10-10	12,300	3/8	5.28	0.59	1.57	1.46	5.20
CGD-13-10	20,900	1/2	6.81	0.75	1.89	1.89	12.06
CGD-16-10	30,900	5/8	8.46	0.87	2.52	2.24	20.70

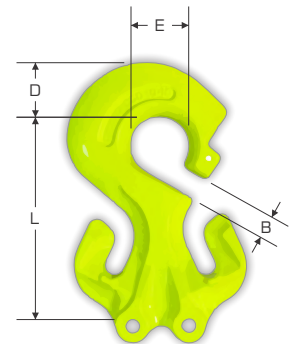

CLD - C-Lok Duo

Masterlink

Product details



For use with master links. All GabiQ C-connectors can be equipped with Quick Pin.

Item Code	WLL [lbs]	Chain Size	Dimensions [in]				Net Weight
			L	B	E	D	
	4:1	[in]					lbs
CLD-6-10	4,600	7/32	1.69	0.43	0.94	0.87	0.70
CLD-8-10	7,700	9/32-5/16	2.28	0.47	1.26	1.14	1.55
CLD-10-10	12,300	3/8	2.91	0.59	1.57	1.46	3.00
CLD-13-10	20,900	1/2	3.70	0.71	2.05	1.81	5.85
CLD-16-10	30,900	5/8	4.69	0.98	2.52	2.24	11.91

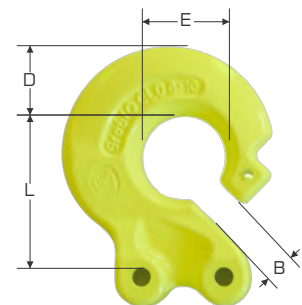

MFH - Masterlink Hybrid

Masterlink

Product details



Designed for crane hooks DIN 15401 and 15402. Designed for use with CL, CLD, CG and CGD. 3- and 4-leg chain slings require CLD / CGD.

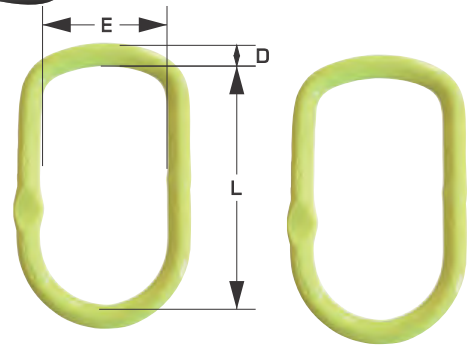

Item Code	WLL (lbs)		Chain Size (in)			Dimensions (in)			Net Weight
	(SF 5:1) EN 1677-4	(SF 5:1) ASTM A-952	1-leg	2-leg	3-4-leg	L	E	D	lbs
MFH-1310-10	16,500	17,600	1/2	3/8	9/32-5/16	9.06	4.92	0.87	4.63
MFH-1613-10	22,000	30,000	5/8	1/2	3/8	9.84	5.31	1.10	8.09
MFH-2016-10	37,500	45,400	3/4	5/8	1/2	11.02	5.31	1.26	11.62
MFH-2220-10	61,700	68,100	1	3/4	5/8	12.60	6.89	1.57	21.50
MFHW-2220-10	58,600	61,700	1	3/4	5/8	13.98	8.86	1.57	24.43

MFX - Oversized Masterlink

Masterlink

Product details



Oversized, for 1- and 2-leg sling. Designed for use with CL, CLD, CG and CGD.

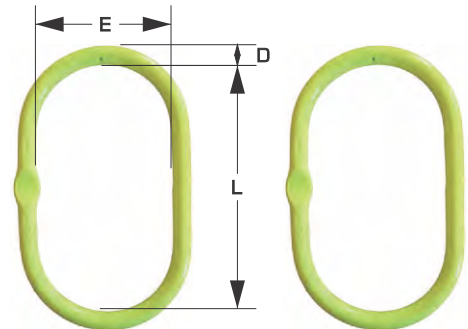

Item Code	WLL (lbs)		Chain Size (in)		Dimensions (in)			Net Weight
	(SF 5:1) EN1677-4	(SF 5:1) ASTM A-952	1-Leg	2-Leg	L	E	D	lbs
MFX-108-10	9,400	11,500	-	9/32-5/16	13.39	7.09	0.98	8.06
MFX-1310-10	16,500	17,600	1/2	3/8	13.39	7.09	1.10	10.18
MFX-1613-10	24,700	30,000	5/8	1/2	13.39	7.09	1.34	15.43
MFX-2016-10	35,300	45,400	3/4	5/8	13.39	7.09	1.57	21.29

MF - Masterlink w/ Engineered Flat

Masterlink

Product details



For 1-, 2-, 3- and 4-leg slings. Designed for use with CL, CLD, CG and CGD. 3- and 4-leg chain slings require CLD / CGD.

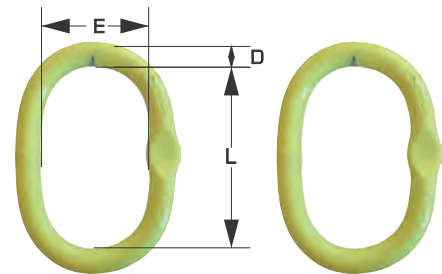

Item Code	WLL (lbs)		Chain Size (in)			Dimensions (in)			Net Weight
	(SF 5:1) EN 1677-4	(SF 5:1) ASTM A-952	1-leg	2-leg	3-4-leg	L	E	D	lbs
MF-6-10	3,300	3,300	7/32	-	-	3.94	2.36	0.43	0.51
MF-86-10	5,500	7,100	7/32, 5/16	7/32	-	4.92	2.76	0.55	0.97
MF-108-10	8,800	11,500	3/8	9/32-5/16	7/32	5.51	3.15	0.67	1.70
MF-1310-10	16,500	17,600	1/2	3/8	9/32-5/16	6.30	3.74	0.87	3.26
MF-1613-10	22,000	30,000	5/8	1/2	3/8	7.48	4.33	1.10	6.17
MF-2016-10	37,500	45,400	3/4	5/8	1/2	9.45	5.51	1.34	11.64
MF-2220-10	55,100	68,100	7/8	3/4	5/8	9.84	5.91	1.57	17.13

Sling Protection
Web Slings
Round Slings
Synthetic Chain Slings
Wire Rope Slings
Chain Slings
Shackles & Turnbuckles
Hooks & Links
Lifting Points
Hoists & Blocks
Lifting Devices
Pipe & Hose Restraints
Tie Down Assemblies
Tie Down Accessories
Towing & Recovery
Rope & Cordage