

*All measurements in mm

FEATURES

- Fixed Frame Plate
- Upper Carrying Bar
- Lower Guiding Bar
- Support Column
- Movable Pressure Plate
- Clip-On EPDM Gaskets
- Tightening Bolts and Nuts
- Adjustable Feet

No. of plates	73
No. of effective plates	71
No. of passes	3
Plate pack dimensions A Measure	255 mm

CONNECTION LOCATIONS

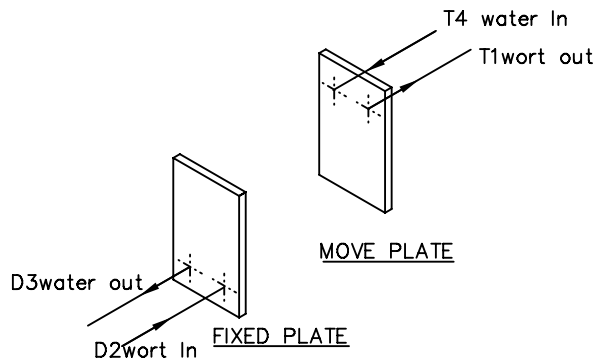

CAUTION: DO NOT TIGHTEN BELOW MINIMUM DIMENSION

	Beer wort	Water
Mass flow rate	5678Kg/h	6839 Kg/h
Inlet temperature	100°C (212°F)	12.7°C (54.9°F)
Outlet temperature	20°C (68°F)	75.5°C (167.9°F)
Pressure drop (Perm/Calc)	80.0/38.5 kPa	80.0/57.2 kPa
Velocity Connection (in/out)	0.630/0.620 m/s	0.968/0.993 m/s

Heat exchanged	498.7 kW
Heat transfer area	9.9 m ²
O.H.T.C clean conditions	4683 W/ (m ² *K)
O.H.T.C service	4229 W/ (m ² *K)
Fouling Resistance* 10000	0.0 m ² *K/W
Additional Excess Surface	10%
Mean Temperature	13.0 K

CONNECTION TYPES

