

FEATURES

- Fixed Frame Plate
- Upper Carrying Bar
- Lower Guiding Bar
- Support Column
- Movable Pressure Plate
- Clip-On EPDM Gaskets
- Tightening Bolts and Nuts
- Adjustable Feet

No. of plates	37
No. of effective plates	35
No. of passes	3
Plate pack dimensions A Measure	129 mm

CAUTION: DO NOT TIGHTEN BELOW MINIMUM DIMENSION

	Beer wort	Water
Mass flow rate	2271 Kg/h	2736 Kg/h
Inlet temperature	100°C (212°F)	12.7°C (54.9°F)
Outlet temperature	20°C (68°F)	75.5°C (167.9°F)
Pressure drop (Perm/Calc)	80.0/21.0 kPa	80.0/30.5 kPa
Velocity Connection (in/out)	0.315/0.310 m/s	0.387/0.397 m/s

Heat exchanged	199.5 kW
Heat transfer area	4.9 m ²
O.H.T.C clean conditions	3887 W/ (m ² +K)
O.H.T.C service	3366 W/ (m ² +K)
Fouling Resistance* 10000	0.0 m ² *K/W
Additional Excess Surface	10%
Mean Temperature	12.1 K

CONNECTION LOCATIONS

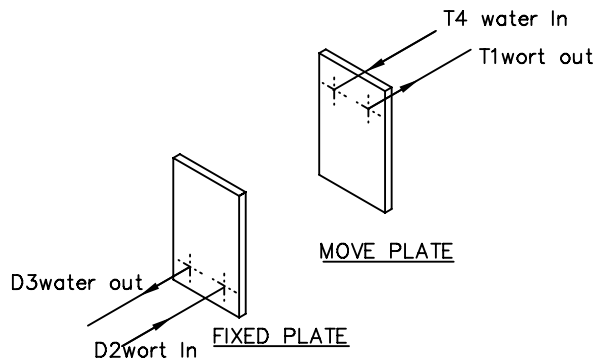

CONNECTION TYPES

