

*All measurements in mm

FEATURES

- Fixed Frame Plate
- Upper Carrying Bar
- Lower Guiding Bar
- Support Column
- Movable Pressure Plate
- Clip-On EPDM Gaskets
- Tightening Bolts and Nuts
- Adjustable Feet

No. of plates	109
No. of effective plates	107
No. of passes	3
Plate pack dimensions A Measure	381 mm

CONNECTION LOCATIONS

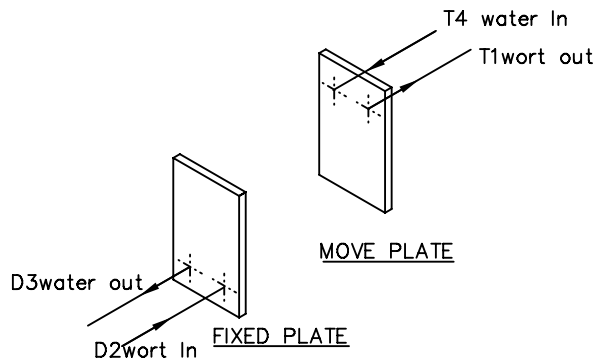

CAUTION: DO NOT TIGHTEN BELOW MINIMUM DIMENSION

	Beer wort	Water
Mass flow rate	9084 Kg/h	10940 Kg/h
Inlet temperature	100°C (212°F)	12.7°C (54.9°F)
Outlet temperature	20°C (68°F)	75.5°C (167.9°F)
Pressure drop (Perm/Calc)	80.0/42.0 kPa	80.0/62.7 kPa
Velocity Connection (in/out)	1.26/1.24 m/s	1.55/1.59 m/s

Heat exchanged	797.9 kW
Heat transfer area	14.9 m ²
O.H.T.C clean conditions	4780 W/ (m ² +K)
O.H.T.C service	4244 W/ (m ² *K)
Fouling Resistance* 10000	0.0 m ² *K/W
Additional Excess Surface	13%
Mean Temperature	13.3 K

CONNECTION TYPES

